



## **Agilent Turbo-V 750 and Turbo-V 850 TwisTorr**

The new molecular-drag  
Technology



# The new molecular-drag technology

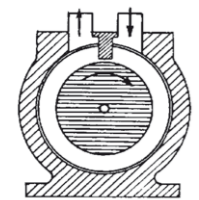
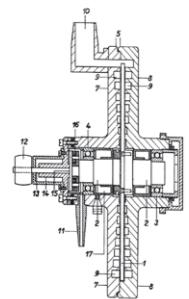
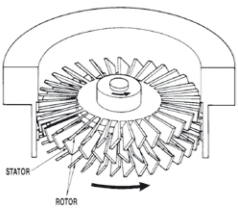
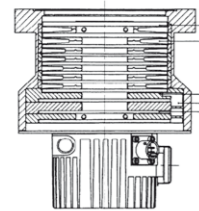

- 2010** ● Agilent Technologies, presents the new TwisTorr molecular drag technology based on its well-known hybrid Turbo Molecular Pump design, introducing a spiral drag section that achieves unmatched performance in both pumping speed and compression ratio in the most compact space available. New state-of-the-art electronics complete this industry leading Turbo Molecular Pump innovation
- 2003** ● With the Turbo-V 2K-G Varian, now Agilent, introduces a fully integrated Turbo pumping system
- 1996** ● Introduction by Varian of microprocessor-based on-board controller units: Navigator line
- 1991** ● Varian introduces a new hybrid type Turbo Molecular Pump: one monolithic rotor provides both high speed (Turbo stages) and high foreline tolerance (MacroTorr stages)
  - Use of ceramic ball bearings with life-time lubrication using a proprietary dry solid lubricant
- 1986** ● Varian begins collaboration with Elettrorava for technology and know-how transfer
- 1980** ● Introduction of ceramic ball bearing technology
  - Compound Turbo Molecular Pumps appear, combining a Turbo section with a Drag section
- 1970** ● Snecma design commercialized by Elettrorava, with manufacturing based in Turin, Italy
- 1965** ● First prototype of axial flow turbo pump (Snecma), with open thin blades
  - This design is the basis for modern TMP technology
- 1960** ● Theoretical basis for the pumping mechanism of axial flow impeller (Shapiro and Kruger, MIT)
- 1958** First Turbo Molecular pumps developed using experimental design:
  - Double-Ended design (Becker), based on a closed cell design using thick rotor and stator blades (this design was abandoned in the late '70s)
  - Axial flow pumping principle, demonstrated in the high vacuum regime (Hablanian)
- EARLY 1900** First Molecular Drag pumps
  - 1912 W.Gaede
  - 1922 F.Holweck
  - 1929 M.Siegbahn



# What is TwisTorr

## Agilent TwisTorr Technology\*

- Pumping effect is created by a spinning rotor disk which transfers momentum to gas molecules.
- Gas molecules are forced to follow spiral groove design on the stator. The specific design of the channel ensures constant local pumping speed and avoids reverse pressure gradients, minimizing power consumption.

(\*) US Patents applications 12/343961 and 12/343980, 24 Dec. 2008.

## Space Saving Design

- Our rotor is based on the proven Agilent monolithic rotor design which positions the TwisTorr Stator between two smooth spinning disks and therefore exploits the pumping action by both disk surfaces in series.
- The double-sided spiral groove design on the TwisTorr stators combines centripetal and centrifugal pumping action in series, greatly reducing the size of the drag section.

## Compression ratio

- Compression ratio for N<sub>2</sub> of a single TwisTorr stage can increase up to a factor of 100 with respect to a MacroTorr stage of the same space and rotor speed, without reducing foreline tolerance and pumping speed.

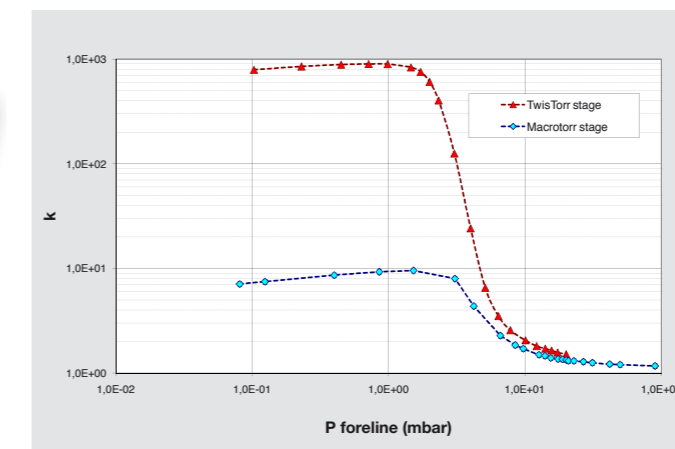
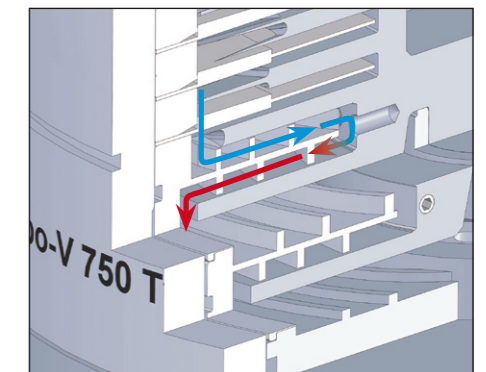
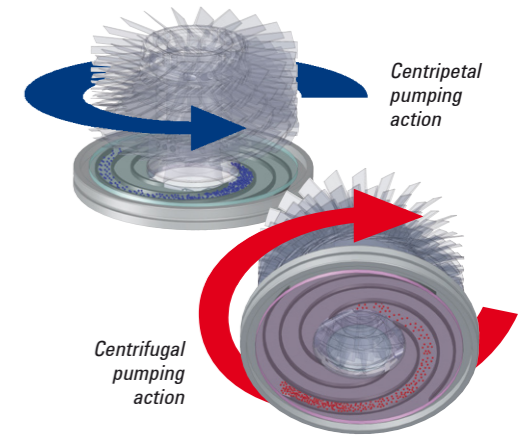

# Agilent TwisTorr Key features

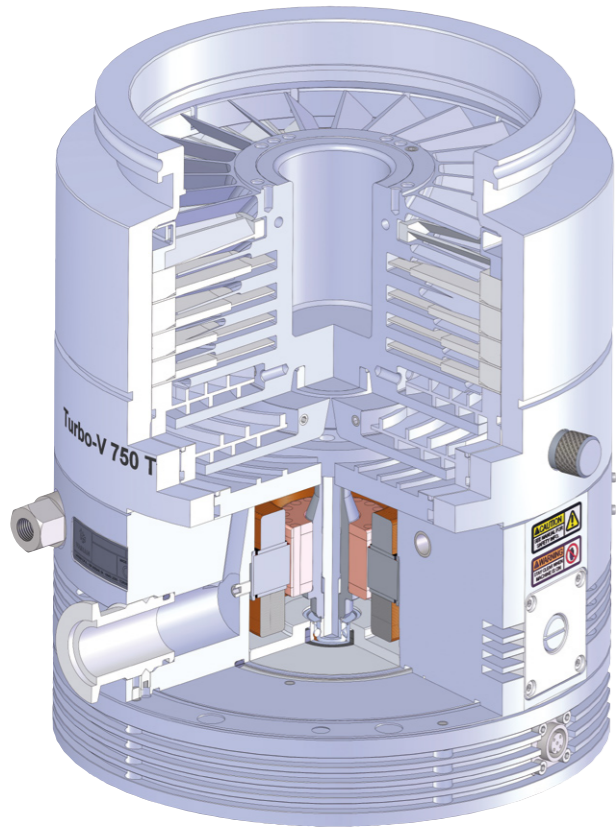

## Leading edge performance

- The new Turbo-V 750 and Turbo-V 850 TwisTorr offer the highest pumping speed in their category for all gases.
- The state of the art TwisTorr technology also achieves the highest compression ratios for light gases in a commercially available Turbo Molecular Pump.
- While offering the highest performance, average power consumption by this new drag section design is reduced by at least 20% compared with previous designs.



## Powerful, compact solution

- The new high performing ultra-compact TwisTorr drag stages permit a compact Rotor design. This enables us to use rotors that are 40% lower in height and weight compared with competitive rotors (using traditional Holweck drag technology).
- The compact rotor design in combination with the new integrated drive electronics allow us to offer a unique solution in a package with a smaller footprint than any Turbo Molecular Pump solution available till now (with or without integrated drive electronics).
- Quick and easy pump installation is made possible by the small footprint, integrated electronics and the possibility of quickly adding optional devices such as an air cooling fan or automatic purge/vent kit connected to and fully controlled by the integrated electronics.



## Advanced electronics

- We offer two different pump solutions:
  - Pumping system with a fully integrated state of the art 48Vdc controller and separate 48Vdc power supply
  - Stand-alone pump with a universal voltage rack type display controller unit, also capable of reading up to two active gauges

- Both controller solutions offer the following features:
  - Logical I/O and serial (RS232/485) communication interfaces
  - Rotational frequency regulation between 350Hz and 825Hz
  - Gas type and cooling mode dependent power control
  - Optional Purge/Vent device that allows for a controlled pump slow down with a modulated vent procedure, in combination with Stop Speed Reading (SSR) function, and purge to protect bearings against dust and corrosive gases
  - T-Plus interface SoftWare for full PC/Laptop control with new Embedded Data Logger Manager function that enables easy data download and graphical display

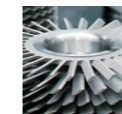

## Design for Reliability

- **VACUUM PERFORMANCE**  
Advanced rotor design in combination with TwisTorr technology has allowed us to reduce the number of pumping stages by 30% compared to conventional designs. The result is a more compact, lighter rotor with improved overall vacuum performance. This compact rotor design also leads to an improved dynamic stability of the rotor and a reduced mechanical load on the suspension.
- **LOW STRESS ROTOR**  
Our unique monolithic rotor is fully automatically machined out of one single piece of advanced high strength aluminium alloy according to our proprietary design. This highly precise process reduces material stress and improves assembly tolerances compared with a traditional stacked rotor design, in which single rotor bladed stages are assembled on a shaft. Our new proprietary inverted shaft fitting process ensures tensile stress-free rotor to shaft connection, reducing stress by 60% compared to traditional fitting.
- **PUMP EFFICIENCY**  
The new 48Vdc electrical motor driven by a dedicated Field Oriented Control algorithm reduces start-up time and improves pump stability under changing gas load conditions. The improved drive efficiency allows higher vacuum performance while reducing average electrical power consumption by 10%.

- **PUMP COOLING AND TEMPERATURE CONTROL**  
State of the art rotor design with improved motor efficiency allows delivery of higher vacuum performance with lower heat dissipation inside the pump. A further improvement to average lower running temperatures comes from improved cooling systems. Our new water cooling solution uses a stainless steel cooling channel fitted inside the pump body using a new mandrel fitting technology. This new solution prevents corrosion and clogging of the water channel. Our new Air-Cooling fan shroud, shaped around the contours of our pump body, optimizes the airflow along to the pump surface.

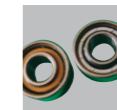

## Clean maintenance-free vacuum

- Modern research and scientific applications require the cleanest vacuum solutions. For these applications we offer our unique UHV-compatible Turbo Molecular Pump design. In our Turbo Molecular Pumps no suspension components are exposed to the UHV side of the system and there are no permanent magnetic bearings that could otherwise negatively disturb the experimental chamber.
- Our high-precision ceramic ball bearings are both installed on the fore vacuum side of the pump and permanently lubricated with our unique proprietary solid lubricant characterized by an extremely low vapor pressure. This solution is completely maintenance free and allows for installation of the pump in any orientation.
- In our family of Turbo Molecular Pumps there is no free oil present for bearing lubrication, eliminating the need for refills and the risk of vacuum chamber contamination



# Agilent Turbo-V 750 TwisTorr System



## Technical Specifications

### Vacuum Performances

Pumping speed for N <sub>2</sub> (*)	N <sub>2</sub> = 700 L/s
Pumping speed for Ar (*)	Ar = 680 L/s
Pumping speed for He (*)	He = 680 L/s
Pumping speed for H <sub>2</sub> (*)	H <sub>2</sub> = 580 L/s
Compression ratio for N <sub>2</sub>	N <sub>2</sub> = 1 x 10 <sup>11</sup>
Compression ratio for Ar	Ar > 1 x 10 <sup>11</sup>
Compression ratio for He	He = 2 x 10 <sup>8</sup>
Compression ratio for H <sub>2</sub>	H <sub>2</sub> = 2.5 x 10 <sup>8</sup>
Base pressure* (with minimum recommended forepump)	<1 x 10 <sup>-10</sup> mbar
Max foreline pressure for N <sub>2</sub>	6 mbar
Inlet Flange size	ISO 160K, CFF 8", ISO 160F
Foreline flange	KF25

### Other

Rotational speed	Selectable from 350 Hz to 825 Hz
Start up time (90% of full speed)	< 3 min
Recommended forepump	PTS300, DS302
Operational position	Any
Cooling options	Forced Air (up to 35 °C ambient temp.) Water (corrosion resistant loop)
Max flange temperature during bake-out (no gas flow)	120°C (CFF), 80°C (ISO)
Noise level (pump at full speed, no load)	FAN off < 52 dB(A) at 1 meter FAN on < 55 dB(A) at 1 meter
Storage temperature	-20 °C to +70 °C
Certifications	CE, CSA, RHOS
Purge and Vent	Standard Purge & Vent ports Automated Purge/Vent device (accessory)
Weight (with integrated controller)	ISO 160 K = 15.9 Kg CF 8" = 22.5 Kg

(\*): According to Pneuport 5608 III, TS 300 PRIMARY PUMP, NO INLET SCREEN

### Controller Specifications

Controller type	Fully integrated electronics
Motor control mode	Field Oriented Control (FOC)
Input voltage	48 Vdc (± 10%)
Maximum input power	450 W
Maximum output power	400 W (pump ramp-up) 300 W (water cooling) 200 W (forced air cooling)
Input voltage for power supply	100 – 240 Vac (± 10%)
Input frequency for power supply	50 – 60 Hz
Maximum input power for power supply	550 VA
Maximum operating power for power supply	450 W
Interface	Navigator standard remote I/O RS 232, RS 485 serial Can accept Profibus external device
Protection category	IP 54
Data Logger	Standard
Stop speed reading	Standard
Automated Purge/Vent device control	Standard
Leak Detector Mode function	Standard

## Ordering Information

### Pumping Systems\*

969-8813	AGILENT Turbo-V 750 ISO 160K On-Board
969-8814	AGILENT Turbo-V 750 CFF 8" On-Board
969-8818	AGILENT Turbo-V 750 ISO 160F On-Board

(\*): Pumping Systems include pump with integrated controller 48 Vdc, inlet screen, 9 and 15 pin mating connectors IP-54.

### Accessories

969-6521	Turbo-V 750/850 TwisTorr Power Supply (5 m cable)
969-9958	Mains cable NEMA Plug, 3m long
969-9957	Mains cable European Plug, 3m long
969-6502	Turbo-V 750/850 TwisTorr Purge/Vent Device
969-6503	Turbo-V 750/850 TwisTorr Fan
969-9883	T-Plus software and serial cable
969-9304	Inlet screen ISO 160 and CFF 8"
969-9347	Water cooling kit (plastic model)
969-9337	Water cooling kit (metallic model)
969-9828	Water kit, Hose tail 1/8G
969-9345	Vibration isolator, ISO 160
969-9335	Vibration isolator, CF 8"
969-9108	Vent flange, NW 10 KF / M8
969-9239	Purge valve with KF16-M12 10 SCCM
969-9240	Purge valve with 7/16-M12 10 SCCM
969-9241	Purge valve KF16-M12 20 SCCM
969-9242	Purge valve 7/16-M12 20 SCCM
969-9261	External Profibus TMP gateway
949-9325	Forepump DS 302, with 1 ph., universal motor
PTS03001UNIV	Triscroll Dry Vacuum Pump PTS 300 single phase, universal motor
PTS03003UNIV	Triscroll Dry Vacuum Pump PTS 300 3 phase, universal motor

## Compression Ratio Vs Foreline Pressure

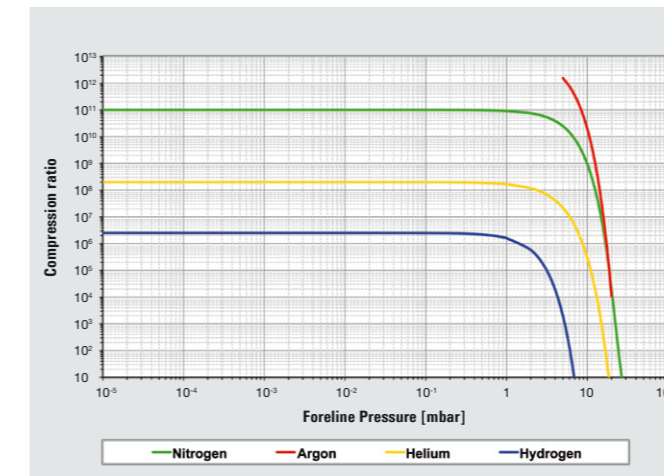

## Pumping Speed

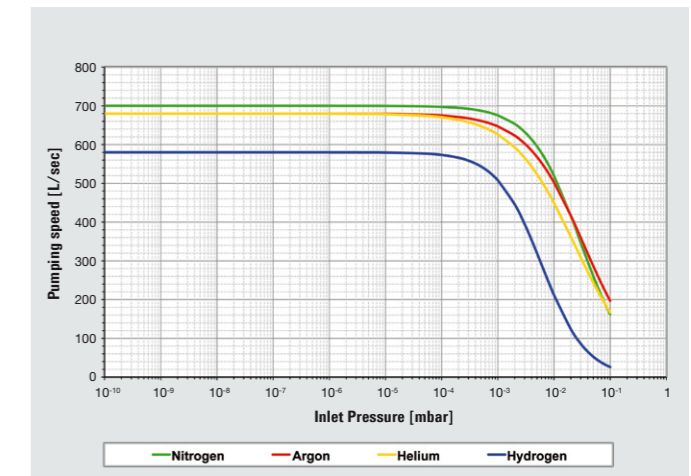

## Outline Drawing

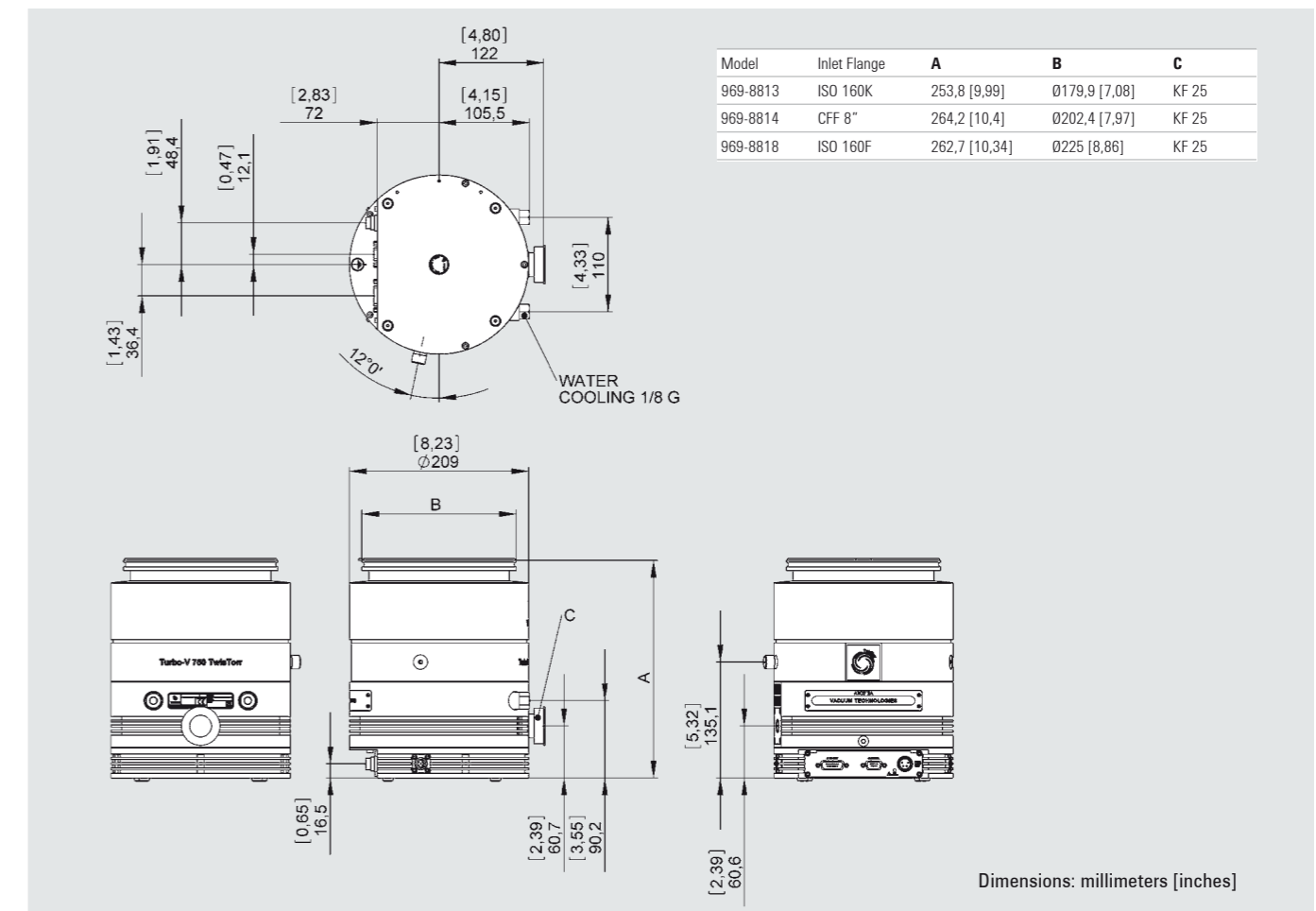

# Agilent Turbo-V 850 TwisTorr System



## Technical Specifications

### Vacuum Performances

Pumping speed for N <sub>2</sub> (*)	N <sub>2</sub> = 750 L/s
Pumping speed for Ar (*)	Ar = 700 L/s
Pumping speed for He (*)	He = 690 L/s
Pumping speed for H <sub>2</sub> (*)	H <sub>2</sub> = 590 L/s
Compression ratio for N <sub>2</sub>	N <sub>2</sub> = 1 x 10 <sup>11</sup>
Compression ratio for Ar	Ar > 1 x 10 <sup>11</sup>
Compression ratio for He	He = 2 x 10 <sup>8</sup>
Compression ratio for H <sub>2</sub>	H <sub>2</sub> = 2.5 x 10 <sup>8</sup>
Base pressure* (with minimum recommended forepump)	<1 x 10 <sup>-10</sup> mbar
Max foreline pressure for N <sub>2</sub>	6 mbar
Inlet Flange size	ISO 200K, CFF 10", ISO 200F
Foreline flange	KF25 (ISO 200K, CFF 10") KF40 (ISO 200F)

### Other

Rotational speed	Selectable from 350 Hz to 825 Hz
Start up time (90% of full speed)	< 3 min
Recommended forepump	PTS300, DS302
Operational position	Any
Cooling options	Forced Air (up to 35 °C ambient temp.) Water (corrosion resistant loop)
Max flange temperature during bake-out (no gas flow)	120°C (CFF), 80°C (ISO)
Noise level (pump at full speed, no load)	FAN off < 52 dB(A) at 1 meter FAN on < 55 dB(A) at 1 meter
Storage temperature	-20 °C to +70 °C
Certifications	CE, CSA, RHOS
Purge and Vent	Standard Purge & Vent ports Automated Purge/Vent device (accessory)
Weight (with integrated controller)	ISO 200 K = 16.1 Kg CF 10" = 22.6 Kg

(\*): According to Pneuop 5608 III, TS 300 PRIMARY PUMP, NO INLET SCREEN

### Controller Specifications

Controller type	Fully integrated electronics
Motor control mode	Field Oriented Control (FOC)
Input voltage	48 Vdc (± 10%)
Maximum input power	450 W
Maximum output power	400 W (pump ramp-up) 300 W (water cooling) 200 W (forced air cooling)
Input voltage for power supply	100 – 240 Vac (± 10%)
Input frequency for power supply	50 – 60 Hz
Maximum input power for power supply	550 VA
Maximum operating power for power supply	450 W
Interface	Navigator standard remote I/O RS 232, RS 485 serial Can accept Profibus external device
Protection category	IP 54
Data Logger	Standard
Stop speed reading	Standard
Automated Purge/Vent device control	Standard
Leak Detector Mode function	Standard

## Ordering Information

### Pumping Systems\*

969-8815	AGILENT Turbo-V 850 ISO 200K On-Board
969-8816	AGILENT Turbo-V 850 CFF10" On-Board
969-8819	AGILENT Turbo-V 850 ISO 200F On-Board

(\*): Pumping Systems include pump with integrated controller 48 Vdc, inlet screen, 9 and 15 pin mating connectors IP-54.

### Accessories

969-6521	Turbo-V 750/850 TwisTorr Power Supply (5 m cable)
969-9958	Mains cable NEMA Plug, 3m long
969-9957	Mains cable European Plug, 3m long
969-6502	Turbo-V 750/850 TwisTorr Purge/Vent Device
969-6503	Turbo-V 750/850 TwisTorr Fan
969-9883	T-Plus software and serial cable
969-9316	Inlet screen ISO 200 and CFF 10"
969-9347	Water cooling kit (plastic model)
969-9337	Water cooling kit (metallic model)
969-9828	Water kit, Hose tail 1/8G
969-9346	Vibration isolator, ISO 200
969-9336	Vibration isolator, CF 10"
969-9108	Vent flange, NW 10 KF / M8
969-9239	Purge valve with KF16-M12 10 SCCM
969-9240	Purge valve with 7/16-M12 10 SCCM
969-9241	Purge valve KF16-M12 20 SCCM
969-9242	Purge valve 7/16-M12 20 SCCM
969-9261	External Profibus TMP gateway
949-9325	Forepump DS 302, with 1 ph., universal motor
PTS03001UNIV	Triscroll Dry Vacuum Pump PTS 300 single phase, universal motor
PTS03003UNIV	Triscroll Dry Vacuum Pump PTS 300 3 phase, universal motor

## Compression Ratio Vs Foreline Pressure

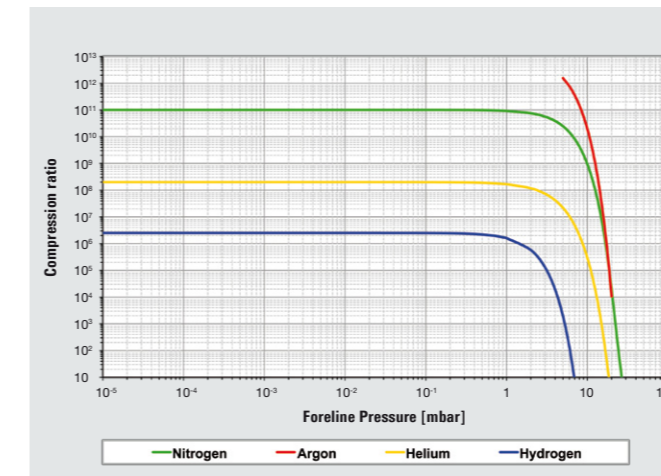

## Pumping Speed

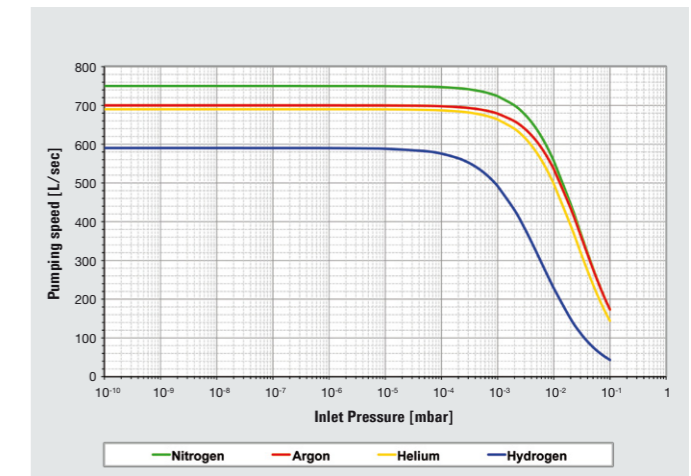

## Outline Drawing

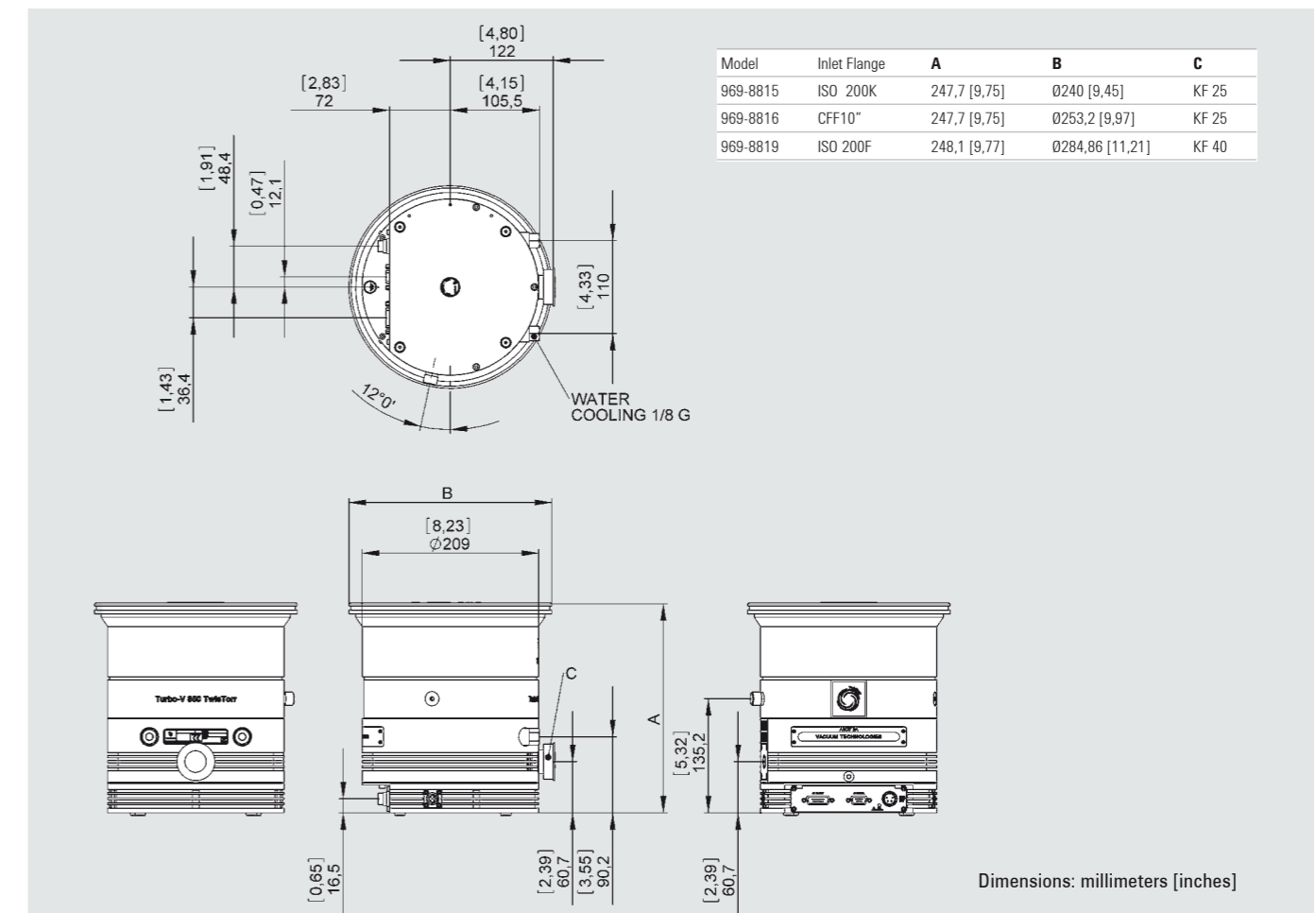



# Agilent Turbo-V 750 TwisTorr Rack



## Technical Specifications

Vacuum Performances	ISO160/CFF8"	CFF 6"
Pumping speed for N <sub>2</sub> (*)	N <sub>2</sub> = 700 L/s	N <sub>2</sub> = 370 L/s
Pumping speed for Ar (*)	Ar = 680 L/s	Ar = 340 L/s
Pumping speed for He (*)	He = 680 L/s	He = 500 L/s
Pumping speed for H <sub>2</sub> (*)	H <sub>2</sub> = 580 L/s	H <sub>2</sub> = 470 L/s
Compression ratio for N <sub>2</sub>	N <sub>2</sub> = 1 x 10 <sup>11</sup>	
Compression ratio for Ar	Ar > 1 x 10 <sup>11</sup>	
Compression ratio for He	He = 2 x 10 <sup>8</sup>	
Compression ratio for H <sub>2</sub>	H <sub>2</sub> = 2.5 x 10 <sup>8</sup>	
Base pressure* (with minimum recommended forepump)	<1 x 10 <sup>-10</sup> mbar	
Max foreline pressure for N <sub>2</sub>	6 mbar	
Inlet Flange size	ISO 160K, CFF 8", CFF 6", ISO 160F	
Foreline flange	KF25	

### Other

Rotational speed	Selectable from 350 Hz to 825 Hz
Start up time (90% of full speed)	< 6 min (with 5 m pump cable length)
Recommended forepump	PTS300, DS302
Operational position	Any
Cooling options	Forced Air (up to 35 °C ambient temp.) Water (corrosion resistant loop)
Max flange temp. during bake-out (no gas flow)	120°C (CFF), 80°C (ISO)
Noise level (pump at full speed, no load)	FAN off < 52 dB(A) at 1 meter FAN on < 55 dB(A) at 1 meter
Storage temperature	-20 °C to +70 °C
Certifications	CE, CSA, RHOS
Purge and Vent	Standard Purge & Vent ports Automated Purge/Vent device (accessory)
Weight	ISO 160 K = 15.7 Kg CF 8" = 22.3 Kg

(\*) According to Pneurop 5608 III, TS 300 PRIMARY PUMP, NO INLET SCREEN

### Controller Specifications

Motor control mode	Field Oriented Control (FOC)
Input voltage	100 - 240 Vac (± 10%)
Input frequency	50 - 60 Hz
Maximum input power	450 VA
Maximum output power	320 W (pump ramp-up) 300 W (water cooling) 200 W (forced air cooling) (Specification with standard cable length 5mt)
Interface	Navigator standard remote I/O RS 232, RS 485 serial Can accept internal Profibus board
Protection category	IP 20
Data Logger	Standard
Stop speed reading	Standard
Active stop	Standard
Automated Purge/Vent device control	Standard
External gauge readout	2 ports compatible with Agilent gauges
Primary pump control	Pilot 2 external configurable relays (48 Vdc (± 10%) - 250 mA MAX)

## Ordering Information

### Pumps

969-6013	AGILENT Turbo-V 750 ISO 160K Rack
969-6014	AGILENT Turbo-V 750 CFF8" Rack
969-6017	AGILENT Turbo-V 750 CFF6" Rack
969-6018	AGILENT Turbo-V 750 ISO 160F Rack

### Controllers

969-9525	AGILENT Turbo-V 750/850-AG Rack CNT, 5 m pump cable incl.
969-9526	AGILENT Turbo-V 750/850-AG Rack CNT Profibus, 5 m pump cable incl.

### Accessories

969-9958	Mains cable NEMA Plug, 3m long
969-9957	Mains cable European Plug, 3m long
969-6502	Turbo-V 750/850 TwisTorr Purge/Vent Device
969-6503	Turbo-V 750/850 TwisTorr Fan
969-6504	Turbo-V 750/850 TwisTorr Purge/Vent 5 M Extension Cable
969-6505	Turbo-V 750/850 TwisTorr Purge/Vent 15 M Extension Cable
969-6506	Turbo-V 750/850 TwisTorr Purge/Vent 25 M Extension Cable
969-6514	Turbo-V 750/850 TwisTorr Fan 5 M Extension Cable
969-6515	Turbo-V 750/850 TwisTorr Fan 15 M Extension Cable
969-6516	Turbo-V 750/850 TwisTorr Fan 25 M Extension Cable
969-6518	Turbo-V 750/850 TwisTorr 10 M Pump Extension Cable
969-6519	Turbo-V 750/850 TwisTorr 20 M Pump Extension Cable
969-9883	T-Plus software and serial cable
969-9304	Inlet screen ISO 160 and CFF 8"
969-9302	Inlet screen CFF 6"
969-9347	Water cooling kit (plastic model)
969-9337	Water cooling kit (metallic model)
969-9828	Water kit, Hose tail 1/8G
969-9345	Vibration isolator, ISO 160
969-9334	Vibration isolator, CF 6"
969-9335	Vibration isolator, CF 8"
969-9108	Vent flange, NW 10 KF / M8
969-9239	Purge valve with KF16-M12 10 SCCM
969-9240	Purge valve with 7/16-M12 10 SCCM
969-9241	Purge valve KF16-M12 20 SCCM
969-9242	Purge valve 7/16-M12 20 SCCM
949-9325	Forepump DS 302, with 1 ph., universal motor
PTS03001UNIV	Triscroll Dry Vacuum Pump PTS 300 single phase, universal motor
PTS03003UNIV	Triscroll Dry Vacuum Pump PTS 300 3 phase, universal motor

## Compression Ratio Vs Foreline Pressure

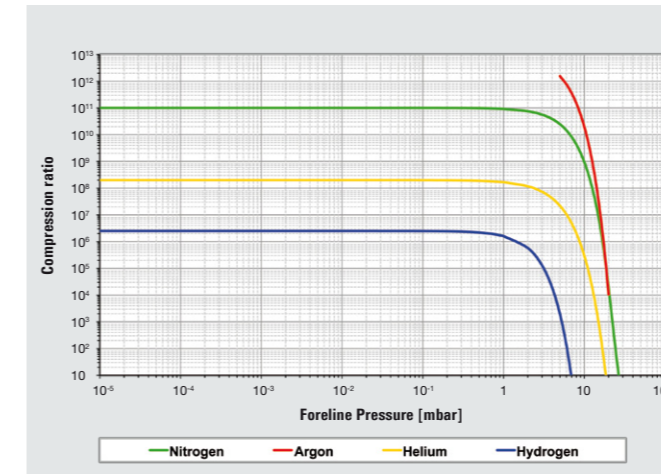

## Pumping Speed

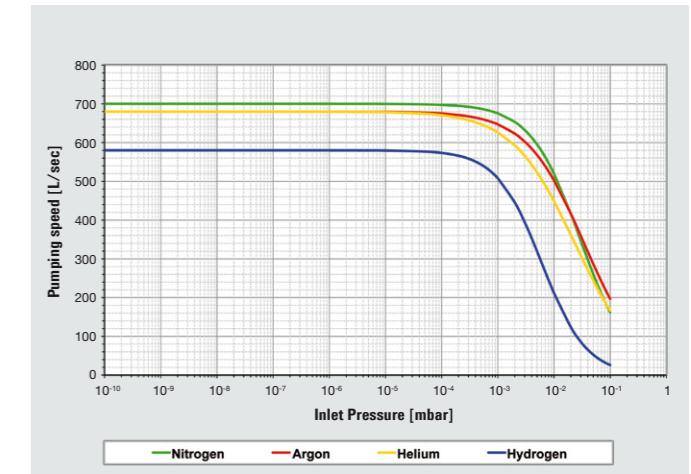

## Outline Drawing

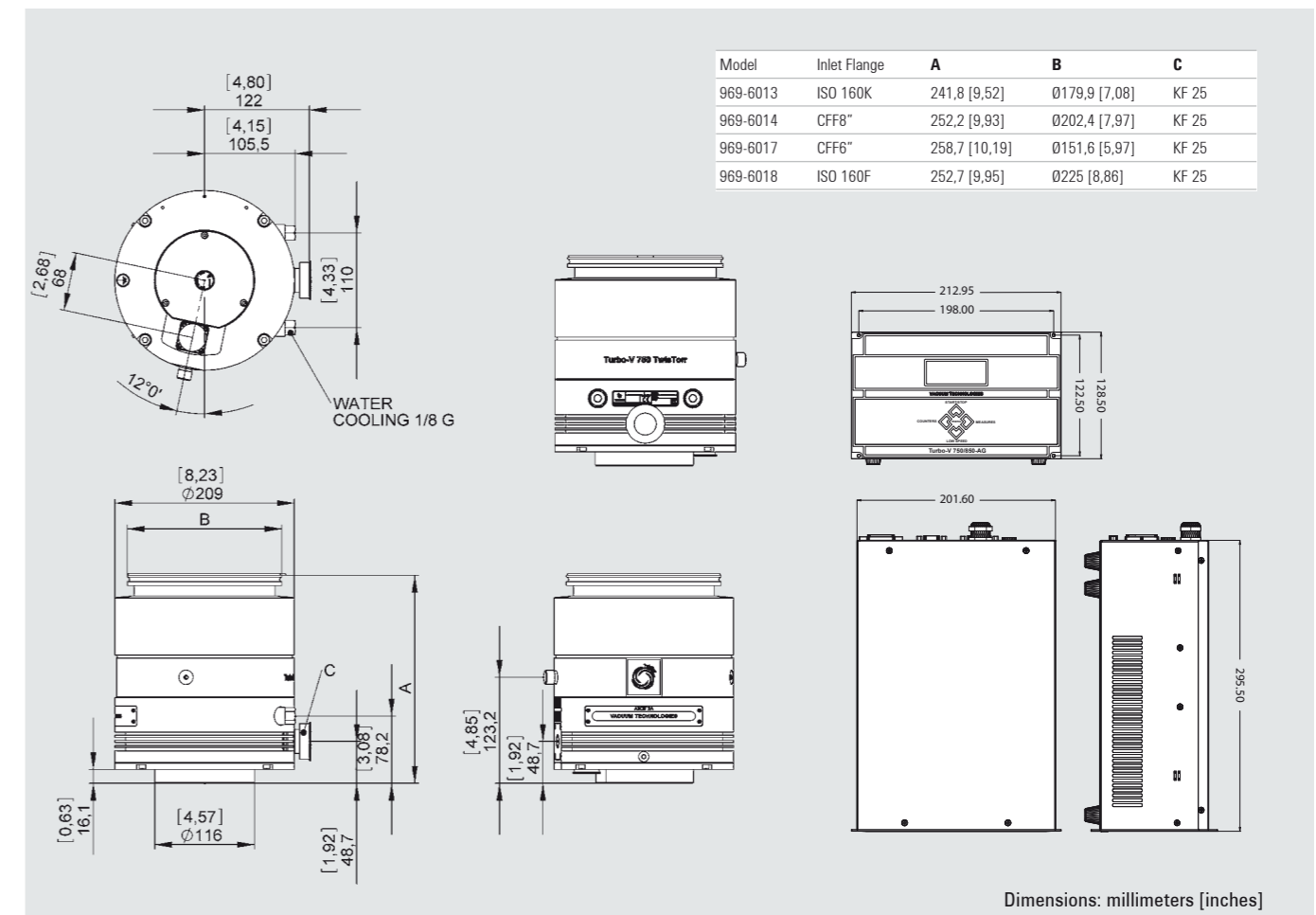

Dimensions: millimeters [inches]

# Agilent Turbo-V 850 TwisTorr Rack



## Technical Specifications

Vacuum Performances	
Pumping speed for N <sub>2</sub> (*)	N <sub>2</sub> = 750 L/s
Pumping speed for Ar (*)	Ar = 700 L/s
Pumping speed for He (*)	He = 690 L/s
Pumping speed for H <sub>2</sub> (*)	H <sub>2</sub> = 590 L/s
Compression ratio for N <sub>2</sub>	N <sub>2</sub> = 1 x 10 <sup>11</sup>
Compression ratio for Ar	Ar > 1 x 10 <sup>11</sup>
Compression ratio for He	He = 2 x 10 <sup>8</sup>
Compression ratio for H <sub>2</sub>	H <sub>2</sub> = 2.5 x 10 <sup>8</sup>
Base pressure* (with minimum recommended forepump)	<1 x 10 <sup>-10</sup> mbar
Max foreline pressure for N <sub>2</sub>	6 mbar
Inlet Flange size	ISO 200K, CFF 10", ISO 200F
Foreline flange	KF25 (ISO 200K, CFF 10") KF40 (ISO 200F)

Other	
Rotational speed	Selectable from 350 Hz to 825 Hz
Start up time (90% of full speed)	< 6 min (with 5 m pump cable length)
Recommended forepump	PTS300, DS302
Operational position	Any
Cooling options	Forced Air (up to 35 °C ambient temp.) Water (corrosion resistant loop)
Max flange temp. during bake-out (no gas flow)	120°C (CFF), 80°C (ISO)
Noise level (pump at full speed, no load)	FAN off < 52 dB(A) at 1 meter FAN on < 55 dB(A) at 1 meter
Storage temperature	-20 °C to +70 °C
Certifications	CE, CSA, RHOS
Purge and Vent	Standard Purge & Vent ports Automated Purge/Vent device (accessory)
Weight	ISO 200 K = 15.8 Kg CF 10" = 22.4 Kg

(\*): According to Pneurop 5608 III, TS 300 PRIMARY PUMP, NO INLET SCREEN

Controller Specifications	
Motor control mode	Field Oriented Control (FOC)
Input voltage	100 - 240 Vac (± 10%)
Input frequency	50 - 60 Hz
Maximum input power	450 VA
Maximum output power	320 W (pump ramp-up) 300 W (water cooling) 200 W (forced air cooling) (Specification with standard cable length 5m)
Interface	Navigator standard remote I/O RS 232, RS 485 serial Can accept internal Profibus board
Protection category	IP 20
Data Logger	Standard
Stop speed reading	Standard
Active stop	Standard
Automated Purge/Vent device control	Standard
External gauge readout	2 ports compatible with Agilent gauges
Primary pump control	Pilot 2 external configurable relays (48 Vdc (± 10%) - 250 mA MAX)

## Ordering Information

Pumps	
969-6015	AGILENT Turbo-V 850 ISO 200K Rack
969-6016	AGILENT Turbo-V 850 CFF10" Rack
969-6019	AGILENT Turbo-V 850 ISO 200F Rack

Controllers	
969-9525	AGILENT Turbo-V 750/850-AG Rack CNT, 5 m pump cable incl.
969-9526	AGILENT Turbo-V 750/850-AG Rack CNT Profibus, 5 m pump cable incl.

Accessories	
969-9958	Mains cable NEMA Plug, 3m long
969-9957	Mains cable European Plug, 3m long
969-6502	Turbo-V 750/850 TwisTorr Purge/Vent Device
969-6503	Turbo-V 750/850 TwisTorr Fan
969-6504	Turbo-V 750/850 TwisTorr Purge/Vent 5 M Extension Cable
969-6505	Turbo-V 750/850 TwisTorr Purge/Vent 15 M Extension Cable
969-6506	Turbo-V 750/850 TwisTorr Purge/Vent 25 M Extension Cable
969-6514	Turbo-V 750/850 TwisTorr Fan 5 M Extension Cable
969-6515	Turbo-V 750/850 TwisTorr Fan 15 M Extension Cable
969-6516	Turbo-V 750/850 TwisTorr Fan 25 M Extension Cable
969-6518	Turbo-V 750/850 TwisTorr 10 M Pump Extension Cable
969-6519	Turbo-V 750/850 TwisTorr 20 M Pump Extension Cable
969-9883	T-Plus software and serial cable
969-9316	Inlet screen ISO 200 and CFF 10"
969-9347	Water cooling kit (plastic model)
969-9337	Water cooling kit (metallic model)
969-9828	Water kit, Hose tail 1/8G
969-9346	Vibration isolator, ISO 200
969-9336	Vibration isolator, CF 10"
969-9108	Vent flange, NW 10 KF / M8
969-9239	Purge valve with KF16-M12 10 SCCM
969-9240	Purge valve with 7/16-M12 10 SCCM
969-9241	Purge valve KF16-M12 20 SCCM
969-9242	Purge valve 7/16-M12 20 SCCM
949-9325	Forepump DS 302, with 1 ph., universal motor
PTS03001UNIV	Triscroll Dry Vacuum Pump PTS 300 single phase, universal motor
PTS03003UNIV	Triscroll Dry Vacuum Pump PTS 300 3 phase, universal motor

## Compression Ratio Vs Foreline Pressure

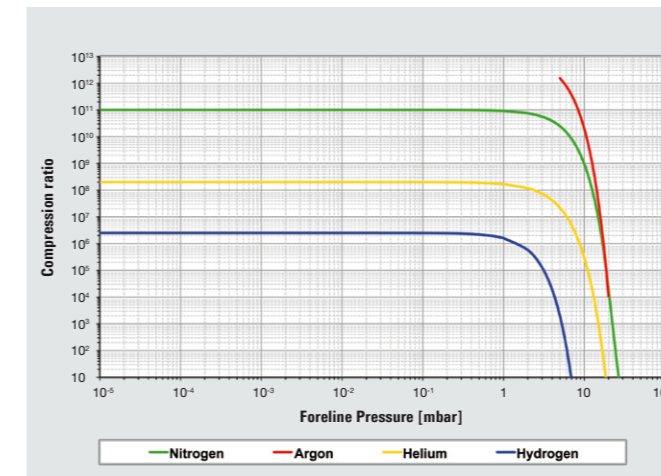

## Pumping Speed

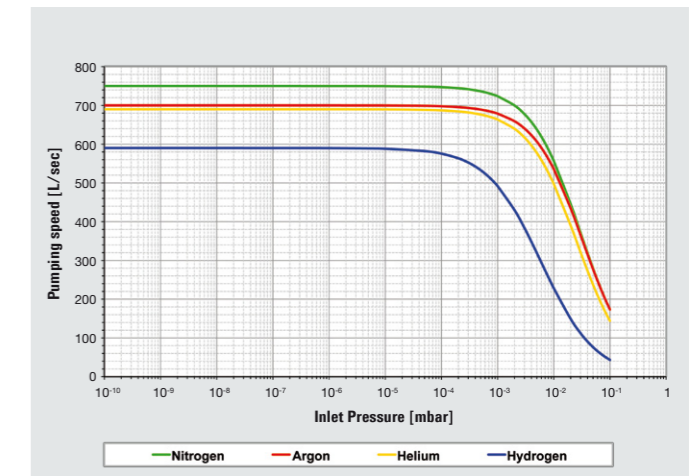

## Outline Drawing

