

Instruction Manual

EXT Compound Turbomolecular Pumps EXT75DX, EXT75iDX, EXT255DX and EXT255iDX



Description		Item Number
EXT75DX	ISO63	B722-41-000
EXT75DX	CF63	B722-42-000
EXT75DX	NW40	B722-43-000
EXT75DX	ISO100	B722-45-000
EXT75DX	ISO100 (NW25 Backing)	B722-46-000
EXT75DX	ISO63 Reversed	B722-48-000
EXT75iDX	NW40	B722-35-000
EXT75iDX	ISO63 (NW16 Interstage)	B722-37-000
EXT75iDX	ISO63 (NW25 Interstage)	B722-38-000
EXT255DX	ISO100	B753-11-000
EXT255DX	CF100	B753-12-000
EXT255iDX	ISO100 (Interstage)	B753-13-000





Declaration of Conformity

We, Edwards,
Manor Royal,
Crawley,
West Sussex RH10 9LW, UK

declare under our sole responsibility that the machine(s)

EXT75iDX NW40 (interstage)	B722-35-000
EXT75iDX ISO63/NW16 (interstage)	B722-37-000
EXT75iDX ISO63/NW25 (interstage)	B722-38-000
EXT75DX ISO63	B722-41-000
EXT75DX CF63	B722-42-000
EXT75DX NW40	B722-43-000
EXT75DX ISO100	B722-45-000
EXT75DX ISO100 (NW25 B-PT)	B722-46-000
EXT75DX ISO63 Reversed	B722-48-000

to which this declaration relates is in conformity with the following standard(s)
or other normative document(s)

EN(ISO)12100-2: 2003	Safety of Machinery: Basic Concepts, General Principles for Design. Technical Principles.
EN 1012-2: 1997	Compressors and Vacuum Pumps. Safety Requirements, Vacuum Pumps.
EN61010-1: 2001	Safety Requirements for Electrical Equipment for Measurement, Control and Laboratory Use.*
EN61326: 1997 (Industrial location, Class B emissions)	Electrical equipment for measurement, control and laboratory use - EMC requirements.
C22.2 No 61010.1-04	Safety requirements for electrical equipment for measurement, Control and laboratory use, Part 1: General requirements.
UL61010-1 (2 nd Edition)	Safety requirements for electrical equipment for measurement, Control and laboratory use, Part 1: General requirements

* The pumps comply with EN61010-1: 2001 when installed in accordance with the instruction manual supplied.

following the provisions of

2006/95/EC	Low Voltage Directive
2004/108/EC	Electromagnetic Compatibility Directive
98/37/EC	Machinery Safety Directive

B. D. Brewster, Technical Manager
Burgess Hill Products

24th October 2007
BURGESS HILL

Date and Place

This product has been manufactured under a quality system registered to ISO9001



Declaration of Conformity

We, Edwards,
Manor Royal,
Crawley,
West Sussex RH10 9LW, UK

declare under our sole responsibility that the machine(s)

EXT255DX ISO100	B753-11-000
EXT255DX CF100	B753-12-000
EXT255iDX ISO100 (Interstage)	B753-13-000

to which this declaration relates is in conformity with the following standard(s)
or other normative document(s)

EN(ISO)12100-2: 2003	Safety of Machinery: Basic Concepts, General Principles for Design. Technical Principles.
EN 1012-2: 1997	Compressors and Vacuum pumps. Safety Requirements, Vacuum Pumps.
EN61010-1: 2001	Safety Requirements for Electrical Equipment for Measurement, Control and Laboratory Use.*
EN61326: 1997 (Industrial location, Class B emissions)	Electrical equipment for measurement, control and laboratory use - EMC requirements.
C22.2 No 61010.1-04	Safety requirements for electrical equipment for measurement, Control and laboratory use, Part 1: General requirements
UL61010-1 (2 nd Edition)	Safety requirements for electrical equipment for measurement, Control and laboratory use, Part 1: General requirements

* The pumps comply with EN61010-1: 2001 when installed in accordance with the instruction manual supplied.

following the provisions of

2006/95/EC	Low Voltage Directive
2004/108/EC	Electromagnetic Compatibility Directive
98/37/EC	Machinery Safety Directive

B. D. Brewster, Technical Manager
Burgess Hill Products

24th October 2007
BURGESS HILL
Date and Place

This product has been manufactured under a quality system registered to ISO9001

This page has been intentionally left blank.

Contents

Section	Page
1	Introduction 1
1.1	Scope and definitions 1
1.2	General description 1
1.3	Drive electronics 2
1.4	Operational features 3
1.4.1	Power limit setting 3
1.4.2	Standby speed 3
1.4.3	Timer 3
1.4.4	Analogue output 4
1.4.5	Automatic vent options 4
1.4.6	Normal speed setting 4
1.4.7	Electronic braking 5
1.5	Logic interface 5
1.5.1	Parallel control and monitoring 5
1.5.2	Full serial control 6
1.5.3	Serial control with parallel monitoring 6
1.5.4	Parallel control with occasional serial monitoring or serial set-up 6
1.5.5	Podule configuration (serial set-up) 6
2	Technical data 7
2.1	General 7
2.2	Pumping media 7
2.3	Vent gas specification and vent control data 13
2.4	Purge gas specification 14
2.5	Cooling water 14
2.6	Materials exposed to gases pumped 14
2.7	Electrical data 15
2.8	Logic interface connector 15
2.9	Podule connector socket 16
2.10	Indicator LEDs 18
2.11	Operating and storage environment 18
3	Installation 19
3.1	Unpack and inspect 19
3.2	Typical installation 19
3.3	Connection to the vacuum system 19
3.3.1	Inlet-screen (supplied fitted) 21
3.3.2	Mechanical fixing 22
3.3.3	Inlet-connection and orientation 22
3.3.4	Base mounting 22
3.3.5	Backing connection 23
3.3.6	Interstage connection (iDX variants only) 23
3.4	Purge gas connection 24
3.4.1	Connect the purge gas 24
3.4.2	Recommended purge gas flow 24
3.5	Electrical installation 24
3.5.1	Introduction 24
3.5.2	Earth (ground) connections 24
3.5.3	Connect the logic interface to the TIC 24
3.5.4	Connect the logic interface to your control equipment 24
3.5.5	Connect the electrical supply 25
3.6	Parallel interface mode 26

3.7	Serial interface mode	27
3.7.1	Connect the serial interface to your control equipment	27
3.7.2	Serial enable	28
3.7.3	Serial protocol	28
3.7.4	Message structure	29
3.7.5	Command set	30
3.7.6	Simultaneous parallel and serial operation	30
3.7.7	Multi-drop mode	33
3.8	Vent options, vent valve connection and control	34
3.8.1	Manual vent valve	34
3.8.2	TAV5 or TAV6 solenoid vent valve	34
3.8.3	Controlled venting	35
3.8.4	Alternative valve connected to the vacuum system	35
3.9	Cooling	36
3.9.1	Introduction	36
3.9.2	Forced air cooling	36
3.9.3	Water-cooling	36
4	Operation	39
4.1	Configuring the DX pump using serial commands	39
4.1.1	Power limit setting	39
4.1.2	Powering a fan from the podule	40
4.1.3	Controlled venting options	40
4.1.4	Standby speed setting	41
4.1.5	Normal speed setting	41
4.1.6	Timer setting and options	42
4.1.7	Analogue signal options	43
4.1.8	Electronic braking options	43
4.1.9	Factory settings	44
4.1.10	Assigning a multi-drop address	44
4.2	Configuring the DX pump using a TIC	45
4.3	Start-up	45
4.3.1	Close the vent valve	45
4.3.2	Pre-start checks	46
4.4	Operation with parallel control and monitoring	46
4.4.1	Start the pump	46
4.4.2	Running at standby speed	46
4.4.3	Stop the pump	46
4.4.4	Parallel monitoring	47
4.5	Operation with serial control and monitoring	47
4.5.1	Delayed start	47
4.5.2	Start the pump	47
4.5.3	Standby speed	47
4.5.4	Stop the pump	48
4.5.5	Temperature readings	48
4.5.6	Link parameter readings	48
4.5.7	Measured motor speed	48
4.6	Simultaneous parallel and serial operation	49
4.7	Operation with a TIC	49
4.8	Decelerating and venting	49
4.9	Operation at extreme conditions	49
4.9.1	Operation with high inlet pressure	49
4.9.2	Operation at high temperatures	50
4.9.3	Operation at over-speed	50
4.9.4	Electrical supply failure	50
4.10	Bakeout	51
5	Maintenance	53
5.1	Introduction	53

5.2	Bearing maintenance	53
5.3	Rotor life	53
5.4	Clean the external surfaces of the pump	53
5.5	Fault finding	54
5.5.1	Flashing error codes	56
5.5.2	Decoding system status words	56
5.5.3	Useful service information	59
6	Storage and disposal	61
6.1	Storage	61
6.2	Disposal	61
7	Service, spares and accessories	63
7.1	Introduction	63
7.2	Service	63
7.2.1	Returning a pump for service	63
7.3	Spares	63
7.3.1	ISX inlet-screen	63
7.3.2	Inlet-strainer	64
7.3.3	Inlet-flange seals	64
7.4	Accessories	64
7.4.1	Installation	64
7.4.2	ACX air-cooler	64
7.4.3	WCX water-cooler	64
7.4.4	BX bakeout band	65
7.4.5	TAV vent-valve and vent-port adaptor	65
7.4.6	VRX vent-restrictor	65
7.4.7	Vent-port adaptor	65
7.4.8	PRX purge-restrictor	66
7.4.9	Vibration isolators	66
7.4.10	FL20K foreline trap	66
7.4.11	Podule connector plug	66
7.4.12	TIC turbo and instrument controllers	66
7.4.13	TIC PC Program	67
	Index	69

For return of equipment, complete the HS Forms at the end of this manual.

Illustrations

Figure	Page	
1	EXT75DX dimensions (mm)	11
2	EXT255DX dimensions (mm)	12
3	Maximum allowed rate of pressure rise during venting: pressure against time (with pump initially at full rotational speed)	13
4	Podule connector plug	17
5	Typical pumping system with a DX pump	20
6	Correct installation of the inlet-screen (EXT75DX)	21
7	Correct installation of the inlet-screen (EXT255DX)	21
8	Logic interface connections - parallel mode	26
9	Logic interface connections - serial mode	27
10	Conceptual diagram for multi-drop connection	29
11	Schematic diagram of the logic interface connections	33
12	Installation of optional accessories and spares	67

Tables

Table	Page
1 Power limits	3
2 General data	7
3 DX pumps technical data	8
4 DX pumps technical data	9
5 DX pumps technical data	10
6 Vent gas specification and vent control	13
7 Purge gas specification	14
8 Cooling water specification	14
9 Logic interface technical data	15
10 Logic interface connector pins	17
11 Podule technical data	17
12 Indicator LEDs	18
13 Operating and storage environment	18
14 Checklist of components	19
15 Summary of commands that can be sent to the DX pump	30
16 Command abbreviations	32
17 Error codes	32
18 Vent options	35
19 Vent-restrictor orifice diameter (with atmospheric pressure at the inlet of the vent-valve)	35
20 Power limit setting	39
21 Analogue signal options	43
22 Behaviour of a pump when the power is re-instated after an electrical supply failure	52
23 Fault finding	54
24 Flashing error codes	56
25 Hexadecimal conversion table	57
26 Status flags	57
27 Example decoding of system status words	58
28 Inlet-flange seals	64
29 Vent restrictors	65

Trademark credits

Windows™ is trademark of Microsoft Corporation.

1 Introduction

1.1 Scope and definitions

This manual provides installation, operation, maintenance and storage instructions for the Edwards DX Compound Turbomolecular Pumps. You must use the DX pumps as specified in this manual. If you do not, the protection provided by the DX pumps may be impaired.

Read this manual before you install and operate the DX pump. Important safety information is highlighted as WARNING and CAUTION instructions; you must obey these instructions. The use of WARNINGS and CAUTIONS is defined below.



WARNING

Warnings are given where failure to observe the instruction could result in injury or death to people.

CAUTION

Cautions are given where failure to observe the instruction could result in damage to the equipment, associated equipment and process.

The units used throughout this manual conform to the SI international system of units of measurement. When flow rates are specified, the abbreviation 'sccm' is used to mean standard cubic centimetres per minute. This is a flow of $1 \text{ cm}^3 \text{ min}^{-1}$ at an ambient temperature of $0 \text{ }^\circ\text{C}$ and a pressure of 1013 mbar ($1.013 \times 10^5 \text{ Pa}$).

In accordance with standard EN61010, the following warning label appears on the DX pump:



Warning - refer to accompanying documentation.



Warning - hot surfaces.

The units used throughout this manual conform to the SI international system of units of measurement; where appropriate US equivalent units of measurement are also given.

1.2 General description



WARNING

Improper use of the equipment could cause damage to it or injury to people. The user is responsible for the safe operation, installation and monitoring of the system.



WARNING

The Podule contains electrolytic capacitors and, under certain fault conditions, may emit dangerous fumes. Ensure that the Podule is operated in a well-ventilated area.

CAUTION

Do not attempt to separate the Podule from the pump since this will cause damage to the electrical connections.

The DX pumps consist of the compound turbomolecular pump with a permanently attached Podule containing drive electronics.

The Podule controls the electrical supply to the pump. It has no manual controls and can only be operated through the logic interface. To operate the DX pump you must connect it to your own control equipment and power supply or alternatively use the Edwards TIC Turbo Instrument Controller or TIC Turbo Controller.

The Podule drives the brush-less d.c. motor in the pump. The pump has three Hall effect devices that operate as rotor position sensors and ensure that the drive current is correctly commutated around the motor phase-windings.

The vacuum pump contains turbomolecular blades and a Holweck drag mechanism on a single shaft; the Holweck mechanism allows operation at higher backing pressures than pure turbomolecular pumps.

DX pumps are supplied with an inlet-screen fitted into the bore of the inlet-flange. Both the EXT255iDX and the EXT75iDX with an NW25 interstage port are supplied with an inlet-strainer that fits into the interstage-port. The inlet-screen and inlet-strainer protect the pump against damage that would be caused by debris entering the pump. The inlet-screen also protects the user against injury from the sharp blades in the pump.

Note: *The EXT75iDX with an NW16 interstage port is not supplied with an inlet-strainer.*

The DX pumps have a vent-port for venting the pump and vacuum system to atmospheric pressure. The pump is supplied with a manual vent-valve fitted; this can be replaced with a TAV5 or TAV6 solenoid-operated vent-valve (available as accessories - see [Section 7](#)).

The DX pumps have a purge-port: an inert purge gas can be introduced to protect the bearing and motor from corrosion, or the bearing lubricant from oxidation. An optional vent-port adapter and purge restrictor can be fitted to the purge-port to control the flow rate of the purge gas and to filter the gas supply. (Refer to [Section 7](#)).

Air-coolers and a water-cooling block are available as optional accessories to cool the DX pumps. (Refer to [Section 7](#)).

1.3 Drive electronics

The Podule contains the drive electronics that control the pump operation and accessories such as a TAV vent valve or air cooler. There is a connector socket on the top of the Podule where the TAV vent valve or air cooler can be plugged-in. (Refer to [Section 2.9](#))

The Podule has two indicator LEDs that signal the status and operation of the pump, that can also be used for fault-finding if a problem should occur. (Refer to [Section 2.10](#))

The drive electronics system has a number of built-in safety features to protect the DX pumps from damage in the event of sustained high pressure or temperature:

- The electronics constantly monitor the temperature inside the Podule and the temperature of the motor within the pump. If either part becomes too hot, the electronics reduce the power supplied to the pump motor and the pump speed will drop. If the pump rotational speed falls below 50% full speed, the electronics may trip into Fail condition, depending on how you have configured the system. (Refer to [Section 1.4.3](#)).
- If the DX pump's inlet pressure increases, the power supplied to the pump-motor increases to counteract the gas frictional load. However, when the built-in maximum power limit is reached, the speed of the pump will start to drop. If the pump rotational speed falls below 50% full speed, the electronics may trip into Fail condition, depending on how you have configured the system. (Refer to [Section 1.4.3](#)).
- In the event of an electrical supply failure, the drive electronics uses the motor within the pump as a generator. This means the DX pumps have their own regenerative supply and do not require a separate battery for emergency power back-up. The regenerated energy is used to maintain the electrical supply to the connector socket on the Podule until the pump speed falls to below 50% of full rotational speed: this will ensure that the vent valve remains shut until below 50% of full rotational speed and will prevent the pump from venting at full speed, provided that there is not too much loading on the 24 V supply to the pump.

1.4 Operational features

In addition to the basic start and stop commands, the DX pumps have several other features for improved functionality. This allows you to tailor the pump operation to your particular application. Refer to [Table 15](#) for factory default settings of the parameters discussed in the following Sections.

1.4.1 Power limit setting

You can select the maximum power that will be drawn by the pump (refer to [Section 4.1.1](#)). The more power you supply, the quicker the pump will accelerate to reach full speed. Therefore if your application requires fast cycling, you should set the power limit to the maximum value. If ramp time is not important in your application, you can use a lower power limit, down to a minimum value, refer to [Table 1](#).

Table 1 - Power limits

Pump	Maximum value setting	Minimum value setting
EXT75DX	120 W	50 W
EXT255DX	200 W	80 W

You must make sure that the power supply you use is capable of delivering sufficient power to the DX pump. By choosing a lower power limit setting, you could use a smaller power supply. For more information, refer to [Section 2.7](#).

1.4.2 Standby speed

In Standby mode the pump rotational speed is lower than the full rotational speed.

If your application does not require the pump to be running at maximum speed at all times, you can use the Standby speed feature rather than switching the pump off. This can save you time since you do not have to stop or vent the pump and you do not have to wait as long for the pump to accelerate back to full speed.

The Standby speed is a user-selectable value (refer to [Section 4.1.4](#)).

1.4.3 Timer

When the pump is started, an internal timer is automatically started within the drive electronics. If the pump fails to reach 50% of full rotational speed within the timeout period, the Podule will signal a Fail and will decelerate the pump to rest. This is a safety feature and prevents the Podule driving the pump at maximum power for a long time, which could cause damage. The pump may fail to reach 50% speed if the gas load is too high (for example if there is a leak in the system), if the backing pump fails, or if the pump is too hot.

The timeout period is a user-selectable feature (refer to [Section 4.1.6](#)), so if your application requires the pump to ramp up slowly, you can extend the timeout period. The Timer is permanently enabled for ramp-up.

The Timer has an additional function: if the pump rotational speed drops below 50% full speed for any reason, you may wish to allow the pump time to recover rather than trigger a Fail condition. The Timer starts as soon as the speed drops to below 50% full speed. If, during the timeout period, the pump recovers to above 50% full speed then the Timer will be reset. If the pump rotational speed fails to recover by the end of the timeout period, the Podule will trigger a Fail condition and will decelerate the pump to rest. When you receive the pump, the Timer function will be enabled, however you can disable it if you wish to. With the Timer disabled, the pump will Fail and decelerate to rest as soon as pump rotational speed falls below 50%.

1.4.4 Analogue output

The Podule produces an analogue output that allows you to monitor four different system parameters:

- Measured pump rotational speed
- Measured motor power
- Measured motor temperature
- Measured controller temperature

The analogue output signal ranges from 0 to 10 V and is directly proportional to the system parameter (refer to [Section 2.8](#)).

Connect the analogue output to a suitable meter or indicator to display the appropriate system parameter or connect to your control equipment (for example, to operate other components in the pumping system at preset values).

You can only monitor one system parameter at a time using the analogue output. However, it is easy to configure the Podule to monitor a different system parameter (refer to [Section 4.1.7](#)).

1.4.5 Automatic vent options

An Edwards TAV vent valve can be connected directly to the DX pump's Podule. The Podule is capable of controlling a number of different venting options.

The drive electronics can control the rate of venting. Using this feature the pump can be vented from full rotational speed in a controlled manner that will not damage the pump bearings. Once the pump rotational speed has dropped to below 50% of maximum speed, it is safe to hard vent (open the vent valve fully.)

There are many venting options available to you, such as:

- Hard vent when rotational speed drops below 50%
- Controlled vent when above 50% speed and hard vent below 50% speed
- Hard vent immediately through a suitable restrictor

A full list of the venting options is given in [Section 3.8](#).

In addition there is a feature that allows a delayed start of the DX pump. With this feature you can close the vent valve before you start the DX pump. This allows the backing pump to reduce the pressure in the vacuum system before starting the DX pump.

If you do not wish to use the Podule to control a TAV vent valve, you could use it to run a fan instead. You can configure the Podule so that the fan is permanently enabled.

1.4.6 Normal speed setting

The Normal Speed is a user-selectable parameter that can be set anywhere from 50% to 100% of full rotational speed. When the pump reaches Normal Speed, a signal is available on the Normal pin of the logic interface connector. You can use this signal to control your application since it shows that pump speed, and therefore vacuum performance, has reached a minimum specific level. The default setting is 80% of full rotational speed. Refer to [Section 4.1.5](#) for instructions on altering the Normal Speed setting.

1.4.7 Electronic braking

The pump has a user selectable Electronic Braking option, which is disabled by default. With this option disabled the pump will draw power from the supply when accelerating and running and will coast down when decelerating.

The Electronic Braking function may be enabled to reduce the pump deceleration time and to recover some energy from the pump. This is achieved by returning power from the pump to the electrical supply. The rate at which electrical energy is returned to the supply is regulated so as to limit the supply voltage to 24 V +10%. In order to achieve the fastest electronic braking times there must be somewhere for the returned power to go such as:

- a supply capable of receiving the returned power
- other devices sharing the 24 V bus with the pump
- a load resistor of approximately 10 Ω switched across the 24 V supply when decelerating the pump

1.5 Logic interface

The Podule can only be operated through the logic interface. The signals on the logic interface are of three types:

- Control inputs: these are switch-type signals that are used to control the pump
- Status outputs: these outputs identify the status of the system
- Analogue output: this provides a 0 - 10 V output for a number of pump parameters.

The logic interface has been designed to include both serial and parallel modes of control and monitoring, operating through one connector. The pump can be operated using either serial or parallel method or some combination of the two.

The logic interface can be plugged directly into the Edwards TIC Turbo Controller or TIC Turbo Instrument Controller and then use the functionality that they provide. Alternatively, the logic interface can be connected to a customers own control system. The most useful arrangements are described in the sections below.

For more information about the logic interface, refer to [Section 2.8](#).

1.5.1 Parallel control and monitoring

The simple parallel interface is a quick and easy way to control the pump; this is the same interface used on existing 24V Edwards Turbo Pumps. The controls that are available to use are Start and Standby. You can monitor the system status using the Normal, Fail and Analogue output signals.

Note: *The Serial Enable switch MUST be open (no connection).*

Refer to [Section 3.6](#) for more detailed instructions of how to use the parallel interface.

A system operating in pure parallel mode has no facility to adjust the configuration settings stored in the Podule (for example, power limit setting or controlled venting options). This would place a restriction in that all these features would be at their factory default settings. However, the Podule could be configured separately before fitting the DX pump to the system. This is covered in more detail in [Section 1.5.5](#).

1.5.2 Full serial control

The serial communications link provides complete control and monitoring using just three signal lines. The Serial data RX and TX use the same connector pins as the parallel signals Standby and Fail respectively.

The Serial Enable signal MUST be linked to 0 V for the system to accept commands in Serial control mode. This is a safety feature and acts as an interlock. In addition, the parallel Start signal must be left unconnected for Serial commands to be accepted in full Serial control mode.

The Podule will still provide the Normal and Analogue signals on the logic interface connector even when operating in full Serial control mode. The status of the Normal signal can also be obtained by interrogating the system status via the Serial interface.

For more information about the Serial interface, refer to [Section 3.7](#).

1.5.3 Serial control with parallel monitoring

Since Normal and Analogue signals remain available even using Serial control mode, it is possible to control the pump via the Serial interface whilst monitoring these signals using a parallel link.

Again, the Serial data RX and TX use the same connector pins as the parallel signals Standby and Fail respectively so these parallel control and monitoring signals are not available. The Serial Enable signal MUST be linked to 0 V and the Start switch must remain open (no connection).

1.5.4 Parallel control with occasional serial monitoring or serial set-up

This method of control is best for users who normally wish to operate the pump in parallel mode but occasionally want to adjust the configuration settings stored in the Podule or to monitor operational status of the pump.

Whilst operating in Parallel mode, the same controls and monitoring signals are available as described in [Section 1.5.1](#). It must be remembered that the Serial data RX shares the same connector pin as the Standby signal so the pump cannot be commanded into Standby speed using this line.

The Serial Enable signal must be linked to 0 V for serial communications to take place. We suggest that you make a special cable for serial communications that includes a link between Serial Enable and 0 V. This way, Serial Enable is automatically activated when the cable is connected and then deactivated when the cable is removed.

1.5.5 Podule configuration (serial set-up)

All the configuration settings stored within the Podule are retained even when power to the DX pump is removed. This means that it is possible to use a separate system to configure the Podule before fitting the DX pump to your application. This gives the benefit of tailoring the pump functionality to a customer application and allows the pump to be operated using a simple parallel interface system.

To configure the DX pump, either use your own simple serial system or use the Edwards TIC Turbo Controller or Turbo Instrument Controller. The TICs have a feature which allows storage of a DX pump's configuration. The configuration can then be downloaded to another DX pump. This is useful when configuring a number of DX pumps with the same settings before they are fitted to a system.

The TIC is supplied with a WindowsTM based PC program which allows the DX pump to be configured from a single PC. The program has a simple user interface which means that it is not necessary to use the ASCII message protocol described in [Section 3.7](#). The TIC PC Program has a facility to save multiple DX pump configurations which can then be downloaded into other DX pumps.

2 Technical data

2.1 General

Table 2 - General data

General items	Reference data
Performance	Refer to Table 3
Dimensions	Refer to Figure 1 and 2
Maximum inlet-flange temperature	
ISO63 / ISO100 / NW40	70 °C with cooling water
DN63CF (EXT75DX) / DN100CF (EXT255DX)	100 °C bakeout, with cooling water
Maximum permitted external magnetic field	
EXT255DX	3.5 mT horizontal field, 7 mT vertical field
EXT75DX	5 mT
Pollution degree	CAN/CSA, UL, EN61010 part 1
Equipment type	Fixed equipment, for indoor use only
Enclosure protection (installed)	
EXT255DX and 255iDX	IP50
EXT75DX and 75iDX/NW25	IP50
EXT75iDX/NW16	IP50

2.2 Pumping media



WARNING

Vent dangerous gases and gas mixtures safely, do not expose people to these gases. If pumping hazardous gases or vapours, observe the safety recommendations of the supplier of the gas/vapour.



WARNING

Do not use the DX pump to pump pyrophoric or explosive gas mixtures, as it is not suitable for this purpose. The pump and its connections are not designed to contain an explosion.



WARNING

In the interstage versions of the DX pumps, gas pumped through the interstage port will mix with gas pumped through the pump inlet. Ensure that the gases will not react or combine to form dangerous gases and substances.



WARNING

Do not expose any part of the human body to vacuum.

CAUTION

Do not use the DX pump to pump gases containing more than 20% oxygen unless the pump is gas purged. If you do, the lubricant will polymerise and the pump may fail prematurely.

CAUTION

Do not use a DX pump to pump mercury vapour and do not allow mercury (for example, from a McLeod gauge) to come into contact with the pump. If you do, the pump rotor may corrode and fail.

Note: Concentrations of gases may be modified by the compression of the pump.

The pumps are designed to pump the following residual gases normally used in high-vacuum systems:

- Air
- Methane
- Propane
- Butane
- Carbon monoxide
- Nitrogen
- Hydrogen
- Carbon dioxide
- Neon
- Krypton
- Helium
- Ethane
- Argon

You can use the pump to pump oxygen and water vapour, subject to the following conditions:

- Oxygen - when the pump is purged by an inert gas, oxygen can be pumped at concentrations above 20% by volume. Refer to [Section 2.4](#) for Purge gas specification. However, if the pump is not purged, the oxygen concentration must be less than 20% by volume.
- Water vapour - you must ensure that vapour does not condense inside the pump; refer to [Section 3.9.3](#).

If you wish to pump a gas not in the list above, contact your supplier for advice. If you do not contact your supplier, you may invalidate the warranty on the pump. The pump is not suitable for pumping aggressive or corrosive gases.

Table 3 - DX pumps technical data

Parameter	EXT75DX ISO63	EXT75DX 63CF	EXT75DX NW40	EXT75DX ISO100
Mass	3.0 kg	4.9 kg	2.9 kg	3.2 kg
Inlet-flange	DN63ISO-K	DN63CF	DN40NW	DN100ISO-K
Outlet-flange	DN16NW	DN16NW	DN16NW	DN16NW
Vent-port	1/8 inch BSP	1/8 inch BSP	1/8 inch BSP	1/8 inch BSP
Purge-port	1/8 inch BSP	1/8 inch BSP	1/8 inch BSP	1/8 inch BSP
Interstage-port (optional)	DN25NW and DN16NW	-	-	-
Inlet pumping speed				
N ₂	61 l s ⁻¹	61 l s ⁻¹	42 l s ⁻¹	66 l s ⁻¹
He	57 l s ⁻¹	57 l s ⁻¹	49 l s ⁻¹	59 l s ⁻¹
H ₂	53 l s ⁻¹	53 l s ⁻¹	48 l s ⁻¹	54 l s ⁻¹
Inlet compression ratio				
N ₂	>1 x 10 ¹¹	>1 x 10 ¹¹	>1 x 10 ¹¹	>1 x 10 ¹¹
He	1 x 10 ⁶	1 x 10 ⁶	1 x 10 ⁶	1 x 10 ⁶
H ₂	5 x 10 ⁴	5 x 10 ⁴	5 x 10 ⁴	5 x 10 ⁴

Table 3 - DX pumps technical data (continued)

Parameter	EXT75DX ISO63	EXT75DX 63CF	EXT75DX NW40	EXT75DX ISO100
Interstage pumping speed, for interstage DX pumps with N₂ (DN16NW port)				
70 sccm flow through interstage-port	10 l s ⁻¹	-	-	-
5 sccm flow through interstage-port	3 l s ⁻¹	-	-	-
Interstage pumping speed, for				
N ₂	-	-	-	-
He	-	-	-	-
Ultimate pressure:				
with rotary vane backing pump: [*]	<5 x 10 ⁻⁹ mbar	<5 x 10 ⁻¹⁰ mbar	<5 x 10 ⁻⁹ mbar	<5 x 10 ⁻⁹ mbar
with diaphragm backing pump: [†]	<5 x 10 ⁻⁸ mbar	<5 x 10 ⁻⁹ mbar	<5 x 10 ⁻⁸ mbar	<5 x 10 ⁻⁸ mbar

^{*} Ultimate pressure 48 hours after bakeout with 2-stage rotary vane backing-pump.

[†] Ultimate pressure 48 hours after bakeout with P_b < 5 mbar (500 Pa).

Table 4 - DX pumps technical data

Parameter	EXT255DX ISO100	EXT255iDX ISO100	EXT255DX 100CF
Mass	6.25 kg	6.25 kg	8.5 kg
Inlet-flange	DN100ISO-K	DN100ISO-K	DN100CF
Outlet-flange	DN25NW	DN25NW	DN25NW
Vent-port	1/8 inch BSP	1/8 inch BSP	1/8 inch BSP
Purge-port	1/8 inch BSP	1/8 inch BSP	1/8 inch BSP
Interstage-port (optional)	-	DN25NW	-
Inlet pumping speed			
N ₂	220 l s ⁻¹ *	220 l s ⁻¹ *	220 l s ⁻¹ *
He	230 l s ⁻¹ *	230 l s ⁻¹ *	230 l s ⁻¹ *
H ₂	180 l s ⁻¹ *	180 l s ⁻¹ *	180 l s ⁻¹ *
Inlet compression ratio			
N ₂	>1 x 10 ⁸	>1 x 10 ⁸	>1 x 10 ⁸
He	4 x 10 ⁵	3 x 10 ⁵	4 x 10 ⁵
H ₂	1 x 10 ⁴	1 x 10 ⁴	1 x 10 ⁴
Interstage pumping speed, for interstage DX pumps with N₂			
70 sccm flow through interstage-port	-	-	-
5 sccm flow through interstage-port	-	-	-
Interstage pumping speed, for			
N ₂	-	10 l s ⁻¹	-
He	-	8 l s ⁻¹	-
Ultimate pressure:			
with rotary vane backing pump: [†]	<5 x 10 ⁻⁹ mbar (DN100ISO-K inlet-flange)	<5 x 10 ⁻⁹ mbar (DN100ISO-K inlet-flange)	<5 x 10 ⁻¹⁰ mbar (DN100CF inlet-flange)

Table 4 - DX pumps technical data (continued)

Parameter	EXT255DX ISO100	EXT255iDX ISO100	EXT255DX 100CF
with diaphragm backing pump: ‡	<5 x 10 ⁻⁸ mbar (DN100ISO-K inlet-flange)	<5 x 10 ⁻⁸ mbar (DN100ISO-K inlet-flange)	<5 x 10 ⁻⁹ mbar (DN100CF inlet-flange)

* Pumping speeds are without inlet-screen or inlet-strainer. Inlet-screens and inlet-strainers reduce speed by approximately 10%.

† Ultimate pressure 48 hours after bakeout with 2-stage rotary vane backing-pump

‡ Ultimate pressure 48 hours after bakeout with $P_b < 5$ mbar (500 Pa).

Table 5 - DX pumps technical data

Parameter	EXT75DX	EXT255DX
Critical backing pressure *		
N ₂	8 mbar	12 mbar
He	6.5 mbar	9 mbar
H ₂	2.5 mbar	2.5 mbar
Minimum backing pump displacement	0.6 m ³ h ⁻¹	0.6 m ³ h ⁻¹
Maximum Continuous Backing Pressure † (at Ultimate Inlet Pressure)		
Nitrogen:		
Water Cooling (40 °C ambient) ‡	4 mbar	7 mbar
Forced Air Cooling (35 °C ambient)	5 mbar	5 mbar
Natural Convection Cooling (30 °C ambient)	2 mbar	2 mbar
Maximum continuous inlet pressure † (at Ultimate Backing Pressure)		
Nitrogen:		
Water cooling (40 °C ambient) ‡	2 x 10 ⁻² mbar	1 x 10 ⁻² mbar
Forced Air cooling at (35 °C ambient)	3 x 10 ⁻² mbar	8 x 10 ⁻³ mbar
Natural Convection Cooling (30 °C ambient)	8 x 10 ⁻³ mbar	2 x 10 ⁻³ mbar
Argon:		
Water cooling (40 °C ambient) ‡	4 x 10 ⁻³ mbar	7 x 10 ⁻³ mbar
Forced Air cooling at (35 °C ambient)	4 x 10 ⁻³ mbar	5 x 10 ⁻³ mbar
Natural Convection Cooling (30 °C ambient)	1 x 10 ⁻³ mbar	1 x 10 ⁻³ mbar
Recommended backing pump **	RV3	RV12
Operating attitude	Vertical and upright through to horizontal ± 2 °	Vertical and upright through to horizontal ± 2 °
Nominal rotational speed	90,000 revolutions per minute	60,000 revolutions per minute
Starting time to 90% speed ††	110 seconds	78 seconds
Sound power level (1 metre away)	< 50 dB(A)	<50 dB(A)

* Pumping speed is reduced to 90% of its original value.

† Above this pressure, rotational speed drops below nominal. Values for maximum continuous inlet pressure obtained using a RV12 backing pump. Refer to Section 3.9 for cooling conditions.

‡ Cooling water temperature at 15 °C. Cooling water flow rate at 30 l hr⁻¹.

** A suitable diaphragm pump with ultimate <5 mbar may also be used.

†† Power limit setting 80 W (EXT75DX), 160 W (EXT255DX).



WARNING

Do not exceed the maximum continuous operating pressure. Doing so can result in dangerous rotor temperatures and will shorten the life of the pump.

Figure 1 - EXT75DX dimensions (mm)

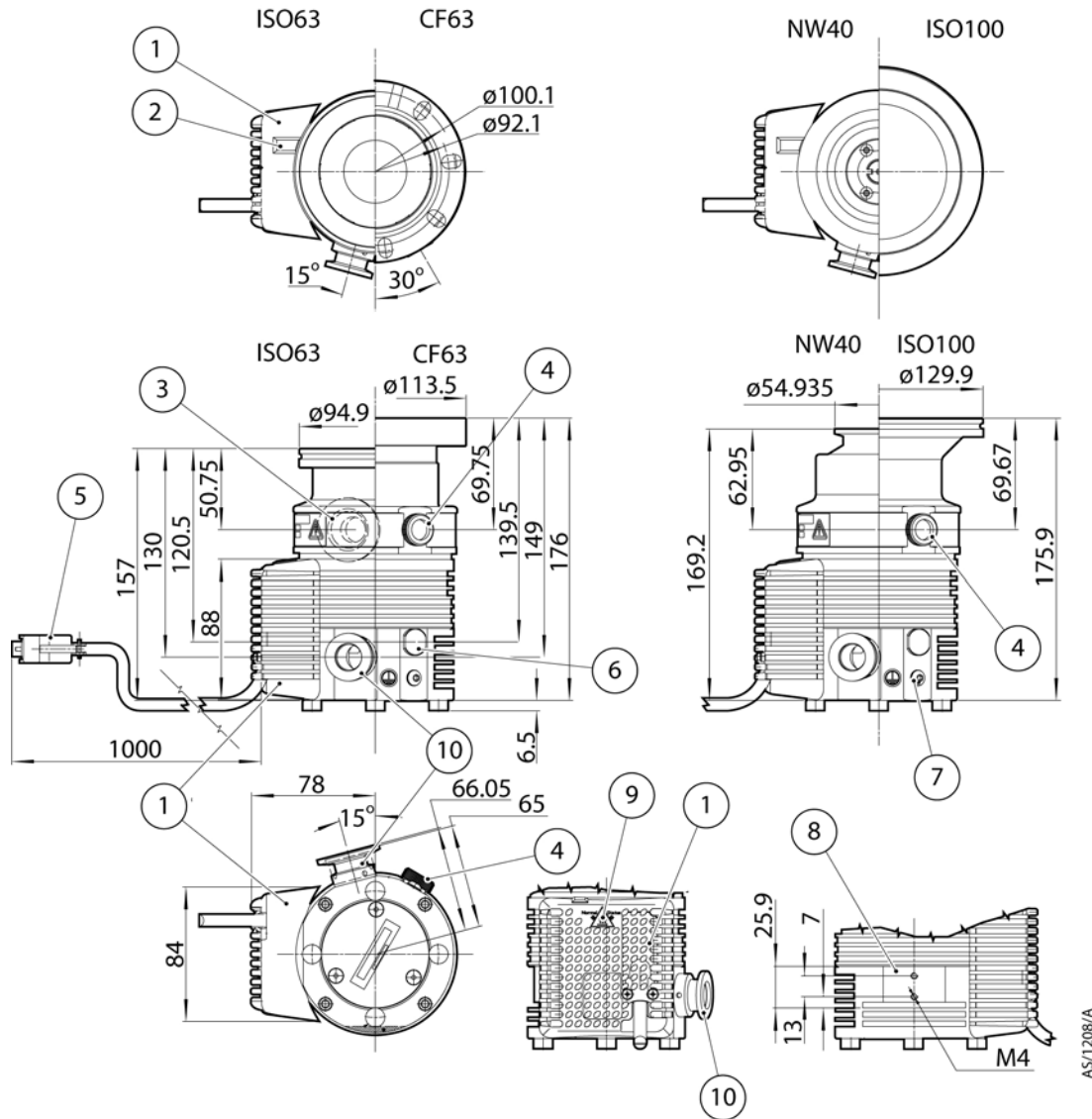

- | | |
|--|--------------------------------|
| 1. Podule | 6. Purge port (blanked off) |
| 2. Podule connector socket (for fan/TAV valve) | 7. Earth connection |
| 3. Interstage port (EXT75iDX only) | 8. Cooling block mounting face |
| 4. Manual vent valve in vent port | 9. Podule indicator LEDs |
| 5. Logic interface connector | 10. Backing port |

AS/1208/A

Figure 2 - EXT255DX dimensions (mm)

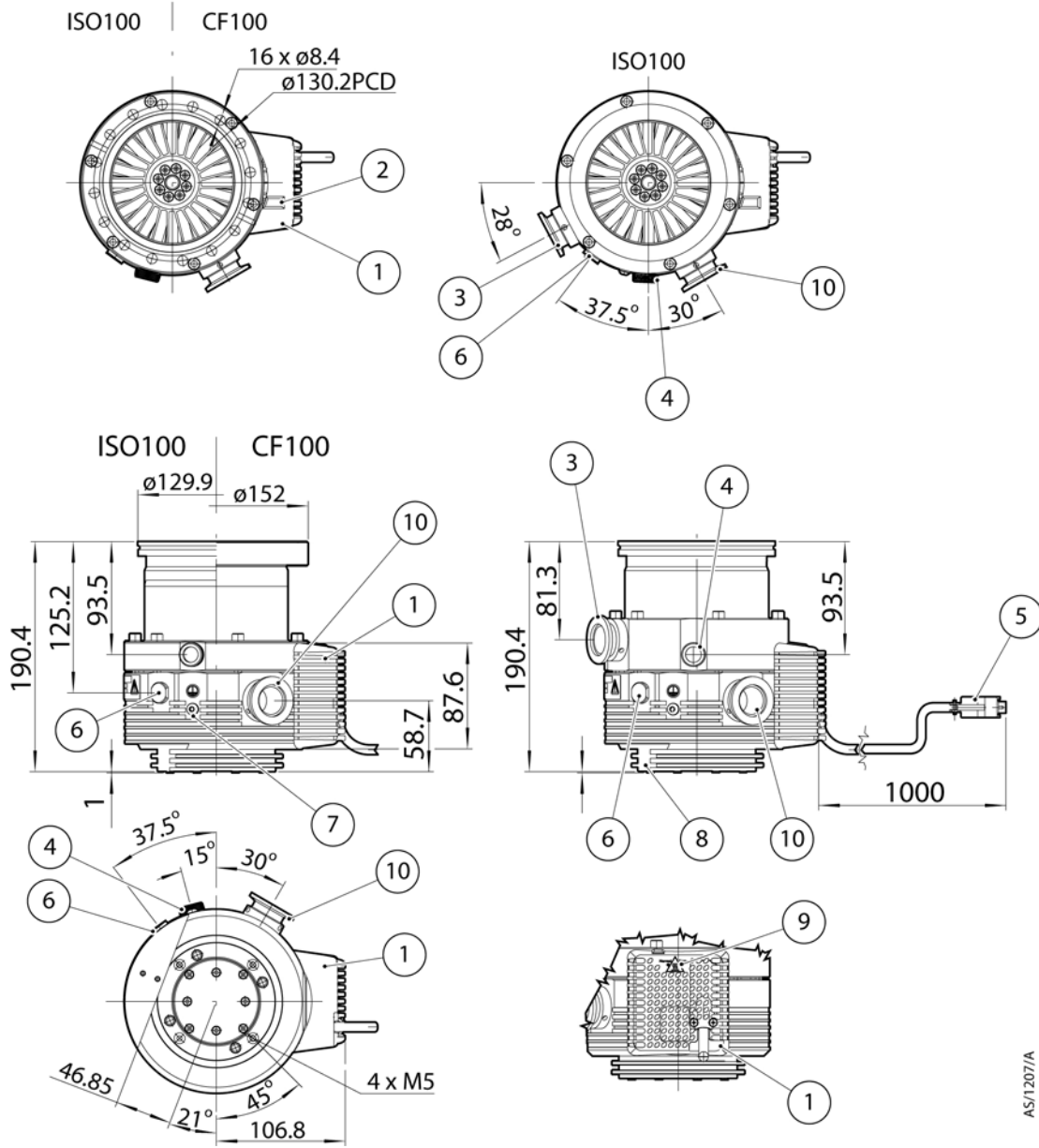

- | | |
|--|---------------------------------|
| 1. Podule | 6. Purge port (blanked off) |
| 2. Podule connector socket (for fan/TAV valve) | 7. Earth connection |
| 3. Interstage port (EXT255iDX only) | 8. Cooling block mounting frame |
| 4. Manual vent valve in vent port | 9. Podule indicator LEDs |
| 5. Logic interface connector | 10. Backing port |

AS/1207/A

2.3 Vent gas specification and vent control data

Although the pump may be vented to atmosphere, high relative humidity of the air may greatly increase the subsequent pump-down time. To reduce pump-down times you should vent with dry, clean gases. Refer to [Section 3.8](#) for a description of the vent options and the vent valve connection and refer to [Section 4.1.3](#) for configuring the venting options.

Table 6 - Vent gas specification and vent control

Vent gas specification and control	Reference data
Vent gas	Dry air, nitrogen, argon or other inert gases
Maximum dew point at atmospheric pressure	-22 °C
Maximum size of particulates	1 µm
Maximum concentration of oil	0.1 parts per million
Recommended time for rotational speed to reach 50%	> 15 seconds
Maximum allowed rate of pressure rise	Refer to Figure 3

Figure 3 - Maximum allowed rate of pressure rise during venting: pressure against time (with pump initially at full rotational speed)

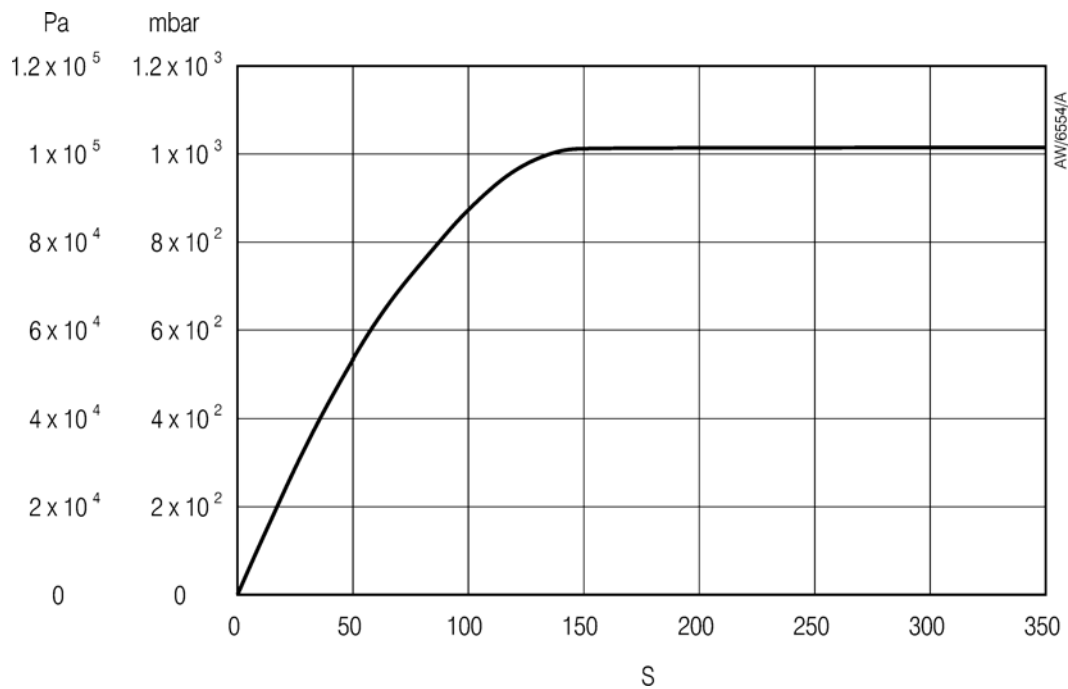

2.4 Purge gas specification

Table 7 - Purge gas specification

Purge gas specification	Reference data
Purge gas	Dry air, nitrogen, argon or other inert gases
Maximum dew point at atmospheric pressure	-22 °C
Maximum size of particulates	1 µm
Maximum concentration of oil	0.1 parts per million
Allowable purge gas flow (when required)	20 to 50 sccm (0.33 to 0.84 mbar l s ⁻¹ or 33 to 84 Pa l s ⁻¹)
Recommended purge gas flow	25 sccm (0.42 mbar l s ⁻¹ , 42 Pa l s ⁻¹)
Maximum allowable purge gas supply pressure	2 bar (gauge); 29 psi, 3 x 10 ⁵ Pa

Table 8 - Cooling water specification

Cooling water specification	Reference data
Quality	Mechanically clean and optically clear with no deposits or turbidity
pH value	6.0 to 8.0
Maximum calcium carbonate concentration	75 parts per million
Maximum chloride concentration	100 parts per million
Minimum oxygen concentration	4 parts per million
Minimum cooling water flow rate (at 15 °C)	15 l hr ⁻¹
Water temperature	Refer to Table 5
Maximum water pressure	5 bar (gauge), 73.5 psig, 6 x 10 ⁵ Pa
Materials exposed to cooling-water	Nickel plated brass

2.5 Cooling water

The above cooling water specification corresponds to a typical high-quality drinking water specification. Check with your water supply authority if you are in doubt about the quality of your supply.

2.6 Materials exposed to gases pumped

The following materials and component types are exposed to the gases pumped:

Aluminium alloys, stainless steels, fluoroelastomer and nitrile O-rings, hydrocarbon lubricant, felt, rare earth magnets, silicon nitride, phenolic resin, carbon-fibre reinforced epoxy resin, fire retardant polypropylene, polyamide and PVC.

2.7 Electrical data

DX pumps can be driven either by your own system or by the Edwards TIC Turbo Instrument Controller or TIC Turbo Controller.

If you wish to use your own system, the size of the power supply you must use depends on your application. The power limit setting determines how quickly you can ramp up the pump and dictates the size of power supply you will need. If you have serial communications capability, or have access to an Edwards TIC, you can select the power limit setting of the DX pump. Refer to [Table 9](#) for the maximum and minimum power limit settings for DX pumps and for the associated maximum input current requirements. If your application requires rapid cycling of the pump, you can achieve faster ramp times if you use a power supply that delivers higher current, up to a maximum in accordance with [Table 9](#).

If you do not have the facility to adjust the power limit setting, you must use a power supply capable of delivering enough current to meet the Edwards factory default power limit setting, shown in [Table 9](#). For the EXT75DX this would be around 4 amps and for the EXT255DX it would be around 7 amps.

If you intend to drive the DX pump using an Edwards TIC, be aware that there are several variants. Contact Edwards to determine which is most suitable for your application.

2.8 Logic interface connector

DX pumps have a 15-way logic interface connector on the end of the logic interface cable (see [Figure 1](#) and [2](#), items 11 and 3 respectively). The logic interface connector can be plugged directly into the Edwards TIC Turbo Instrument Controller or TIC Turbo Controller. You must use a suitable connector mating half (not supplied) to connect the DX pump to your own equipment. Refer to [Table 9](#) for the connector mating half type and to [Table 10](#) for Logic Interface connector pins for the electrical connections.

Table 9 - Logic interface technical data

Logic interface item	EXT75DX	EXT255DX
Connector *	15-way D-type male	15-way D-type male
DX pumps electrical supply:		
Allowable voltage range (including any ripple)	24 V d.c. +5%, -10% (21.6 to 25.2 V d.c.)	24 V d.c. +5%, -10% (21.6 to 25.2 V d.c.)
Maximum voltage ripple	0.5 V r.m.s.	0.5 V r.m.s.
Maximum input current with maximum power limit setting	<6 A at 24 V during ramp	<10 A at 24 V during ramp
Maximum input current with minimum power limit setting	<3 A at 24 V	<5 A at 24 V
Fuse (or equivalent current limiting device) rating	6 A type 'T' IEC approved or 6 A time delay fuse UL/CSA approved	10 A type 'T' IEC approved or 10 A time delay fuse UL/CSA approved
Factory default setting	80 W	160 W
Maximum power limit	120 W	200 W
Minimum power limit	50 W	80 W
Hardware control input signal:		
Enabled control voltage: low (close)	0 to 0.8 V d.c. ($I_{out} = 0.55$ mA nominal)	0 to 0.8 V d.c. ($I_{out} = 0.55$ mA nominal)
Disabled control voltage: high (open)	4 to 26.4 V d.c. (Internal pull up to 6.35 V nominal)	4 to 26.4 V d.c. (Internal pull up to 6.35 V nominal)

Table 9 - Logic interface technical data (continued)

Logic interface item	EXT75DX	EXT255DX
Analogue output:		
Output voltage	0 to 10 V d.c. (directly proportional to measured parameter) Motor speed: 0 - 1500 Hz (0-100%) Motor power: 0 - 120 W Motor temperature: 0 - 100 °C Controller temperature: 0 - 100 °C	0 to 10 V d.c. (directly proportional to measured parameter) Motor speed: 0 - 1000 Hz (0-100%) Motor power: 0 - 200 W Motor temperature: 0 - 100 °C Controller temperature: 0 - 100 °C
Output current	≤ 5 mA	≤ 5 mA
NORMAL status output:		
Type	Open collector transistor	Open collector transistor
< Normal speed (default 80%)	Off (2.2 kΩ pull up to 12 V d.c.)	Off (2.2 kΩ pull up to 12 V d.c.)
≥ Normal speed	On (<0.8 V d.c. sinking 20 mA)	On (<0.8 V d.c. sinking 20 mA)
Rating	20 mA to 0 V	20 mA to 0 V
FAIL status output:		
Type	Open collector transistor	Open collector transistor
Fail	Off (3.3 kΩ pull up to 12 V d.c.)	Off (3.3 kΩ pull up to 12 V d.c.)
OK	On (<0.1 V d.c. sinking 1.7 mA, <0.8 V d.c. sinking 20 mA)	On (<0.1 V d.c. sinking 1.7 mA, <0.8 V d.c. sinking 20 mA)
Rating	20 mA to 0 V	20 mA to 0 V

* Mating half of connector not supplied.

2.9 Podule connector socket

The DX pump has a 2-way Podule Connector Socket in the top of the Podule. When you receive the pump, this connector will be concealed by a black protective cover. If you intend to use the connector, this cover should be removed by levering with a small screwdriver. The mating plug for this connector is supplied with the pump.

The connector is intended to drive a vent valve or fan connected to the two pins. The connector mating plug is shown in [Figure 4](#), with the polarity of the pins marked when the vent valve/fan is energised.

The podule connector plug is available as an accessory, see [Section 7.4](#).

Figure 4 - Podule connector plug

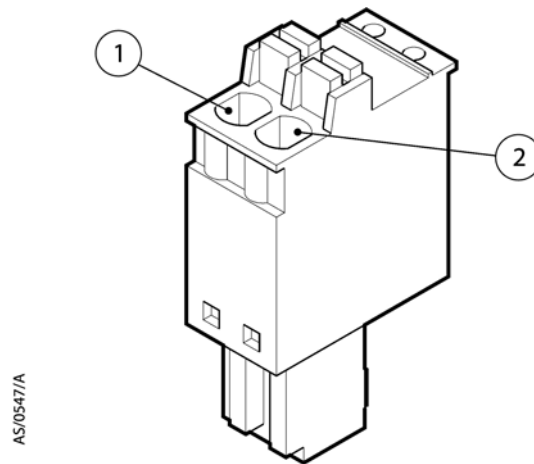

1. Negative terminal
2. Positive terminal

Table 10 - Logic interface connector pins

Pin Number	Signal	Polarity	Use
2	0 V Control reference	-	0 V reference for all control and status signals
3	START/STOP control input	-	Connect to Pin 2 to start pump
4	STANDBY control input / Serial RX	-	Connect to Pin 2 to enable standby speed
5	Serial enable	-	Connect to Pin 2 to enable serial interface mode
7	FAIL / Serial TX	-	Logic high when fail condition exists in parallel mode
9	Analogue output	Positive	0 - 10 V output proportional to measured output
10	Chassis / Screen	-	Screen
12	Chassis / Screen	-	-
15	NORMAL status output	-	Logic low when pump rotational speed is at normal speed or above
8, 13, 14	Electrical supply: 0 V	-	
1, 6, 11	Electrical supply: 24 V	Positive	

Table 11 - Podule technical data

Description	Data
Connector plug	Phoenix part number FKMC1881325
Voltage output	24 V d.c. +10%, -20% (19.2 to 26.4 V d.c.)
Current output	120 mA

2.10 Indicator LEDs

The DX pump has two indicator LEDs, shown in Figure 1 and 2 as item 8.

Table 12 - Indicator LEDs

LED	Description
Status LED	This yellow LED flashes with a 50% duty cycle at the rotational frequency of the pump motor. At high speeds it appears continuously on. The LED switches off when the rotational speed is very low or stopped. In a fail condition this LED flashes in a sequence to indicate error codes and can be used for fault finding. Refer to Section 5.5.
Normal LED	This green LED remains on all the time that the pump rotational speed is above the Normal speed setting, irrespective of whether the pump is accelerating or decelerating.

Note: If excessive electrical load is applied to the Normal output line, the Normal LED may illuminate.

2.11 Operating and storage environment

Table 13 - Operating and storage environment

Range	Data
Ambient operating temperature range	5 °C to 40 °C
Ambient operating humidity range	10 to 90% RH (non-condensing)
Maximum operating altitude	2000 m
Ambient storage temperature range	-30 °C to 70 °C

3 Installation

3.1 Unpack and inspect

Take care when you unpack the pump to avoid excessive shocks that could damage the bearings and reduce the life of the pump. The pump is supplied with the inlet and outlet sealed to prevent entry of dust and vapour. Do not remove these seals until you are ready to install the pump on your vacuum system.

Remove all packing materials and check the pump. If the pump is damaged, notify your supplier and the carrier in writing within three days; state the Item Number of the pump together with your order number and your supplier's invoice number. Retain all packing materials for inspection. Do not use the pump if it is damaged.

Check that your package contains the items listed in [Table 14](#). If any of these items is missing, notify your supplier in writing within three days.

If the pump is not to be used immediately, store the pump in suitable conditions, following the procedure described in [Section 6.1](#).

Do not discard the packing materials; retain them to re-package the pump should you need to return it for service.

Table 14 - Checklist of components

Quantity	Description	Check (✓)
1	DX pump with inlet-screen fitted	<input type="checkbox"/>
1	Inlet seal (either trapped O-ring, Co-seal or copper compression gasket suitable for the inlet-flange type)	<input type="checkbox"/>
1	Connector (24 V) - for driving accessories from Podule socket	<input type="checkbox"/>
1	Inlet-strainer (iDX fitted in the NW25 interstage port only)	<input type="checkbox"/>

Note: An inlet-strainer is not available for the NW16 interstage port of the EXT75iDX.

3.2 Typical installation

A typical pumping system with a DX pump is shown in [Figure 5](#).

The accessories available for the DX pumps are detailed in [Section 7.4](#); the accessories are shown in [Figure 10](#).

3.3 Connection to the vacuum system



WARNING

Ensure that all wires and piping are routed appropriately to avoid the risk of tripping.



WARNING

Install the pump in the vacuum system before the logic interface cable is connected to the control equipment and before the electrical supply is connected. This will ensure that the pump cannot operate accidentally causing injury to people.

We recommend that the system is leak tested after installation has been completed.

Figure 5 - Typical pumping system with a DX pump

AW/6556/A

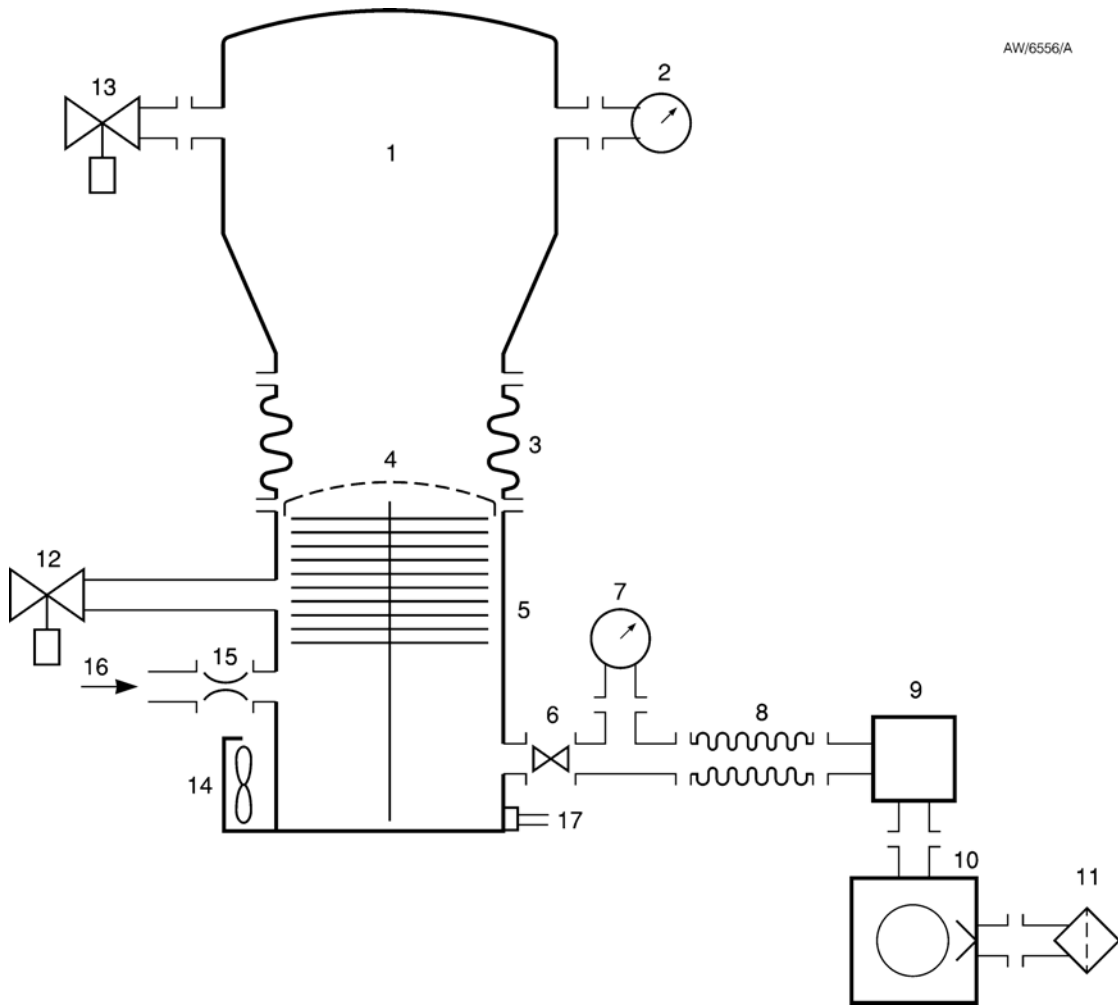

- 1. Vacuum system
- 2. High-vacuum gauge
- 3. Vibration isolator
- 4. Inlet-screen
- 5. DX pump
- 6. Backing valve
- 7. Vacuum gauge
- 8. Flexible bellows
- 9. Foreline trap
- 10. Rotary backing pump
- 11. Mist filter
- 12. Vent valve
- 13. Alternative position for vent valve
- 14. Air cooler
- 15. PRX purge restrictor
- 16. Regulated purge gas supply
- 17. WCX water-cooler and connections

3.3.1 Inlet-screen (supplied fitted)



WARNING

Removal of the inlet-screen will expose the risk of injury from sharp edges.

Do not remove the inlet-screen unless you can be sure that there is no danger that debris can fall into the pump. If the inlet-screen is removed, the pumping speed will increase by up to 10%. Do not remove the inlet-screen until you are ready to mount the pump onto your system, since the screen protects you from exposure to sharp edges.

It is not possible to remove the inlet-screen from a pump with an NW40 inlet-flange (EXT75DX only).

To remove the inlet-screen from a pump with an ISO or CF inlet-flange, use a bent wire hook or small screwdriver to carefully lever the inlet-screen out from the inlet-flange.

To replace an inlet-screen, locate it as centrally as possible over the ISO or CF inlet-flange and then, with your fingers spread evenly around the edge of the screen, push it firmly downwards. If they are not already in place, the tangs must be snapped into the locating groove in the inlet-flange using a suitable tool to press them into position.

Figure 6 - Correct installation of the inlet-screen (EXT75DX)

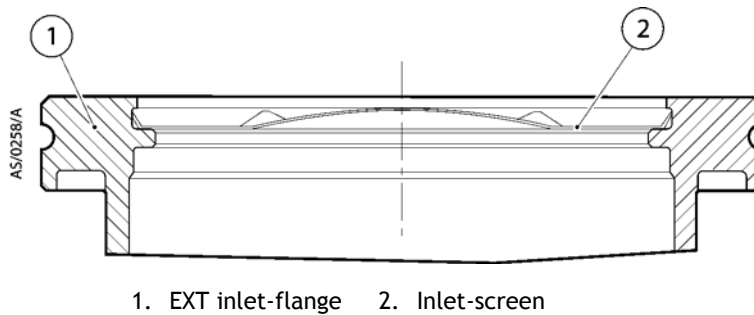
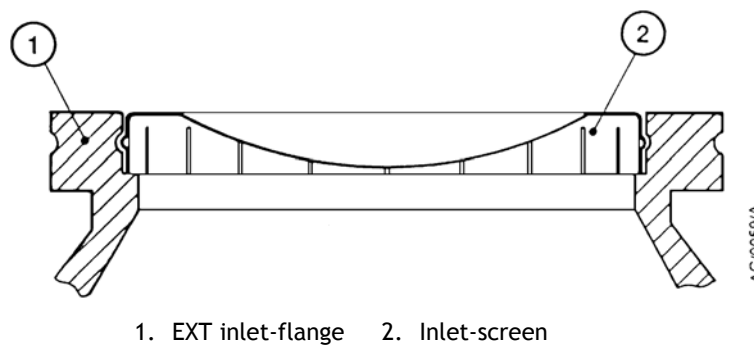

Figure 7 - Correct installation of the inlet-screen (EXT255DX)



3.3.2 Mechanical fixing



WARNING

Do not operate the pump until it is securely fixed. If the pump seizes, the stored energy of the rotor can cause rapid movement of the pump, which may cause further damage and injury to people.

There are two ways in which the DX pumps can be securely fixed. The ideal fixing for a DX pump is via its inlet flange to a rigid, firmly fixed vacuum system - refer to [Section 3.3.3](#). If this is not possible because of the nature of the vacuum system then the base of the pump must be fixed to a firm support, refer to [Section 3.3.4](#) for instructions on base mounting the pump.

3.3.3 Inlet-connection and orientation

The pump can be securely fixed to the vacuum system via the inlet-flange. The pump can be mounted in any attitude from the vertical and upright through to horizontal ($\pm 2^\circ$). If the pump is mounted horizontally, and you are using a rotary vane pump to back your DX pump then the backing port must point vertically downwards ($\pm 20^\circ$) to reduce the risk of contamination from the backing pump oil.

Make sure that the pump-inlet and all components fitted to the pump-inlet are clean and dust-free. If the pump-inlet is not kept clean, the pump-down time may be increased.

The inlet connections for the EXT75DX are CF flange, ISO flanges and the NW flange. The inlet connections for the EXT255DX are CF flange and the ISO flange:

- If the pump has a CF flange, use the copper compression gasket supplied with the pump and use a full complement of bolts to connect the inlet-flange of the pump to the vacuum system.
- If the pump has an ISO flange, use the Edwards trapped O-ring supplied with the pump and use a minimum of four claw clamps (each torqued to 10 Nm) to connect the inlet-flange of the pump to the vacuum system. Alternatively, use a rotatable collar and the trapped O-ring supplied with the pump to connect the inlet-flange of the pump to the vacuum system; use a full complement of bolts with the rotatable collar.
- If the pump has an NW flange, use the centring ring supplied with the pump and a metal NW clamp to connect the inlet-flange of the pump to the vacuum system. In this case you must fix the base of your pump to a firm support, as described in [Section 3.3.4](#).

All inlet flange bolts must be re-tightened once the system is under vacuum. Ensure that no torques or other forces are transmitted to the pump from the vacuum system or the associated pipelines. If necessary, fit an inlet vibration isolator between the pump inlet and the vacuum system (refer to [Section 7.4](#)). In this case you must fix the base of your pump to a firm support, as described in [Section 3.3.4](#).

3.3.4 Base mounting

The base of the DX pump can be fixed to a firm support using the tapped fixing holes. Refer to [Figure 1](#) and [2](#) for fixing hole details.

Note: For EXT75DX only, the four screw-in rubber feet must be removed from the four tapped fixing holes before the pump can be base mounted.

We advise the following requirements should be met to ensure the pump remains secure in the event of a total pump seizure:

Support must withstand a destructive torque of:	333 Nm (EXT75DX) 620 Nm (EXT255DX)
Fixing screws:	To ISO898-1 strength class 12.9 (nom. tensile strength 1200 MPa)
Screw engagement length:	6 mm minimum
Fastening torque:	6 Nm (0.61 kgf.m) (EXT75DX) 12 Nm (1.22 kgf.m) (EXT255DX)

This method of fixing must be used if your pump supports the weight of the vacuum system. The weight of the vacuum system must be no more than 10 kg for EXT75DX and 20 kg for EXT255DX.

3.3.5 Backing connection



WARNING

Ensure safe ducting of the backing line if oil mist or hazardous substances are present.



WARNING

To avoid over pressurising the pump, the exhaust line should be restricted when venting from a positive pressure gas supply.

CAUTION

Do not use the DX pumps with a backing pressure below 5×10^{-4} mbar (5×10^{-2} Pa). Lower backing pressures will increase the evaporation rate of the lubricating oil and so may reduce the life of the bearings.

Use suitable vacuum tubing and connectors to connect the NW flange of the backing-port to your backing-pump. If necessary, use flexible pipe or bellows to reduce the transmission of vibration from the backing-pump to the DX pump.

We recommend that you use an Edwards EM, RV or XDS Scroll backing-pump. The recommended size of backing-pump required is indicated in [Table 5](#). A larger or smaller backing-pump may also be suitable, depending upon the application is intended for.

The DX pumps are suitable for use with diaphragm backing-pumps although the effect of higher backing pressure on the pump's performance and cooling requirements should be noted. Refer to [Table 5](#) and [Section 2.1](#).

3.3.6 Interstage connection (iDX variants only)

Use suitable vacuum tube and connectors to connect the interstage-port to your vacuum system or to the outlet flange of another turbo or compound turbomolecular pump (if using an iDX pump to back another pump). Leave the inlet-strainer in the interstage-port, unless you are sure that debris cannot be drawn into the interstage-port.

Note: *The EXT75iDX with NW16 interstage-port is not supplied with an inlet-strainer fitted.*

3.4 Purge gas connection

3.4.1 Connect the purge gas

To supply a purge gas to the pump, remove the plug fitted in the purge-port, fit a vent-port adaptor (refer to [Section 7.4](#)) and connect the purge gas supply to the vent-port adaptor. The purge gas must comply with the specification given in [Section 2.4](#).

3.4.2 Recommended purge gas flow

The recommended purge gas flow for typical applications is 25 sccm ($0.42 \text{ mbar l s}^{-1}$, 42 Pa l s^{-1}). This flow will protect the pump when pumping oxygen in concentrations above 20% by volume.

The flow rate of the purge gas must be limited to the allowed range, specified in [Section 2.4](#). To limit the flow rate, use a flow controller or a pressure regulator and calibrated flow restrictor. The PRX10 purge restrictor accessory (refer to [Section 7.4](#)) is suitable for this purpose. Adjust the PRX10 as described in the instruction manual supplied with the accessory.

3.5 Electrical installation

3.5.1 Introduction



WARNING

You must make sure that the pump is electrically bonded to earth. If you do not, the system could become hazardous live in the event of a live conductor touching a metallic surface.

The electrical installation must be carried out by a suitably-qualified person. Always make the electrical connections to the DX pump after the pump has been installed on your vacuum system.

Earth the pump using the connection provided and refer to [Section 3.5.2](#).

You can operate the DX pump using the Edwards TIC Turbo Instrument Controller or TIC Turbo Controller, refer to [Section 3.5.3](#). You can also control the DX pump using your own system, refer to [Section 3.5.4](#) for information about control and to [Section 3.5.5](#) for instructions on how to connect your electrical supply.

3.5.2 Earth (ground) connections

We recommend that you fit a separate earth (ground) conductor to earth the DX pump. Use an un-insulated braid or a separate insulated green/yellow conductor, and use the M5 x 10 screw and shake proof washer supplied (fitted to the earth hole on the pump) to secure the earth conductor to the pump. The impedance between the pump-body and the earth connection point must be $< 0.1 \Omega$.

3.5.3 Connect the logic interface to the TIC

If you are using the Edwards TIC Turbo Instrument Controller or TIC Turbo Controller to power and control your pump, the DX pump logic interface cable connects directly into the back of the TIC. Refer to the TIC Instruction Manual for further information.

3.5.4 Connect the logic interface to your control equipment

If you wish to operate the DX pump using your own control system, use a suitable connector mating half (not supplied), to connect your control equipment to the connector on the logic interface cable (refer to [Table 9](#)). When you make the electrical connections to the DX pump described in the following sections, refer to [Table 10](#) for full details of the logic interface connector pins.

You can control the DX pump using a hardware parallel control interface and via commands sent over a serial interface.

If you wish to control the DX pump using the hardware Parallel Interface, refer to [Section 3.6](#) for more information. If you wish to use the Serial Interface, see the instructions given in [Section 3.7](#). The logic interface provides the facility to work in either Parallel or Serial control modes: however, you cannot send commands in both modes simultaneously, refer to [Section 3.7.6](#).

3.5.5 Connect the electrical supply



WARNING

This product requires a separate power supply (not included). The power supply should be adequately protected against a hazardous live condition (for example, in case of a short circuit).



WARNING

Incorporate a suitable isolation device in the electrical supply. Locate the switch in an easily accessible position and mark it as the disconnecting device for the DX pump. If you do not, you will not be able to switch off the DX pump in an emergency.



WARNING

Incorporate a suitable fuse or current limiting device, as specified in [Section 2.8](#), in the 24 V supply line to the DX pump. If you do not and a fault develops, the DX pump may develop a hazardous surface temperature or present a fire hazard.



WARNING

Do not exceed the maximum supply voltage. Excessive supply voltage will cause permanent damage to the control electronics and may result in a mechanical hazard in some failure conditions.

CAUTION

When connecting the DX pump to the power supply, ensure that all 3 pins for the 24 V connection and all 3 pins for the 0 V connection on your connector mating half are connected to the power supply.

Refer to [Figure 8](#) for a schematic diagram of the logic interface connections.

The electrical supply you provide for the DX pump must meet the requirements of BS EN 61010-1 / C22.2 1010-1. Ensure that hazardous voltages as defined in EN61010 cannot be present on the electrical interface to the DX pump.

The DX pump 0 V is not referenced to earth (ground). Ensure that the electrical supply offers a path ($\leq 22 \text{ k}\Omega$) between 0 V and earth.

Refer to [Table 10](#) - Logic Interface Connector Pins when you connect the electrical supply to your connector mating half.

Figure 8 - Logic interface connections - parallel mode

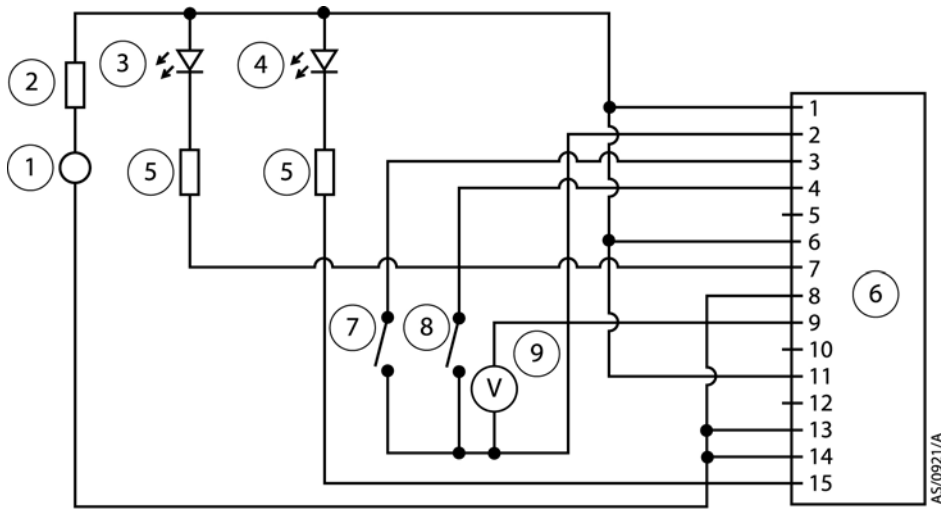

- | | |
|--|--|
| 1. 24 V dc electrical supply | 6. DX pump logic interface |
| 2. Fuse | 7. Start switch |
| 3. Optional LED indicator - system OK | 8. Optional standby switch |
| 4. Optional LED indicator - normal speed | 9. Optional voltmeter to monitor analogue output |
| 5. Current limit resistor for LED | |

3.6 Parallel interface mode

CAUTION

If you use the Normal and Fail lines to drive the coils of d.c. relays you must include a back EMF suppression diode in parallel with each relay coil to protect the DX pump.

1. Connect your control equipment to the control input pins of your logic interface mating half. Refer to Table 10, which identifies the Logic Interface connector pins. The control inputs are as follows:
 - Start
 - Standby Speed

To activate either of these control inputs, you must connect the control input pin to the 0 V control reference.

For example, to start the pump, connect pin 3 (Start / Stop) to pin 2 (0 V Reference). To stop the pump, break the connection between pin 3 and pin 2.

Note: Serial Enable is also a control input but is not required in a system operating purely in Parallel Mode. Make sure that there is no connection to Serial Enable (pin 5).

2. To monitor Analogue Output, connect your control equipment to the pump Analogue Output (pin 9) and to pin 2 of your logic interface mating half.

When you receive your pump, the Analogue Output will be configured to monitor pump rotational speed. If you wish to monitor any other parameter you must re-configure your DX pump using commands over the Serial Interface. Refer to Section 3.7 for further details.

3. To monitor the Normal status output, connect your control equipment to the Normal status output (pin 15) and to pin 2 of your logic interface mating half. You can use the output to control other devices in your pumping system. The output can drive a low power relay of up to 24 V coil rating.

- To monitor the Fail status output, connect your control equipment to the Fail output (pin 7) and to pin 2 of your logic interface mating half. You can use the output to control other devices in your pumping system. The output can drive a low power relay of up to 24 V coil rating.

3.7 Serial interface mode

The Serial Interface allows you to control the DX pump and to interrogate its operational status using a number of commands. There is a multi-drop mode that allows you to communicate with more than one DX pump whilst using just one control system.

3.7.1 Connect the serial interface to your control equipment

CAUTION

When connecting the DX pump to a PC, remember that the 0 V pin on the RS232 connector may well be connected to earth through the PC. If this is the case ensure that the 0 V rail of the 24 V supply is not also connected to earth at some other point such as at the power supply. If you do not wish to have the 0 V rail of the 24 V supply connected to earth at the PC an opto-isolated interface to the PC should be used.

The DX pump can connect directly to the RS232 serial input on a PC as shown in Figure 9. In this configuration the PC is the serial link master and the DX pump is the slave. The distance over which the serial link will work is dependent on any difference in voltage between the 0 V at the sending and receiving end. If the 0 V reference at the receiving end is within 0.3 V of the 0 V Control Reference pin on the DX pump control connector then the serial link should be capable of operating at distances up to 6 m. An interface circuit external to the DX pump may be required for longer distances.

The software in the DX pump is capable of operating with several pumps connected to a single serial link master. This is referred to as multi-drop mode. However, the serial interface driver in the DX pump is based on the RS232 standard, which is only intended for point to point serial links. Some additional hardware will be required to link several DX pump units to a single serial link master. A concept drawing of one possible arrangement is shown in Figure 10.

Figure 9 - Logic interface connections - serial mode

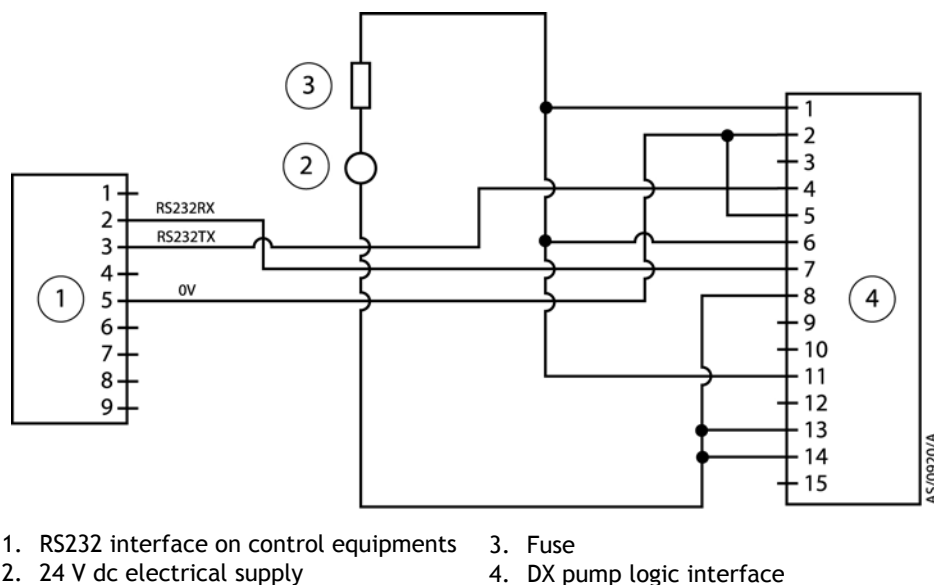

3.7.2 Serial enable

To send a Serial message you must first activate Serial Enable. This is achieved by linking the Serial Enable input signal (pin 5) to pin 2 of your logic interface mating half. We recommend that you incorporate this link into your Serial communications cable so that the Serial Enable is only activated when the serial cable is connected. When you subsequently remove the cable, Serial Enable will become inactive.

Serial Enable acts as an interlock for commands sent over the Serial Interface. If the pump is running (having been sent a Serial Start command) and the Serial Enable subsequently becomes inactive, the pump will trigger a fail condition and will decelerate to rest. To clear this fail condition, you must re-activate the Serial Enable and send a Serial Stop command.

3.7.3 Serial protocol

The Serial Interface link is set to 9600 Baud, 8 bits, 1 stop, no parity with no handshaking. The commands are made up from printing ASCII characters. The maximum message size you can send is 80 characters, including start and end characters.

Note: *All alphabetical characters must be sent in upper case format.*

Every complete command message you send will receive a response - either a status code or a data return. The DX pump can only deal with one message at a time. It will only accept a new message once the response to the previous message has been returned.

If the DX pump receives characters that are not framed inside start and stop characters, it will ignore them. Messages with the stop character missing will be discarded with no response when a new start character is received. If the DX pump receives an unrecognisable message between the start and stop characters, it will return an appropriate error message.

Refer to [Section 3.7.7](#) for more information about operating the DX pumps in multi-drop mode.

Figure 10 - Conceptual diagram for multi-drop connection

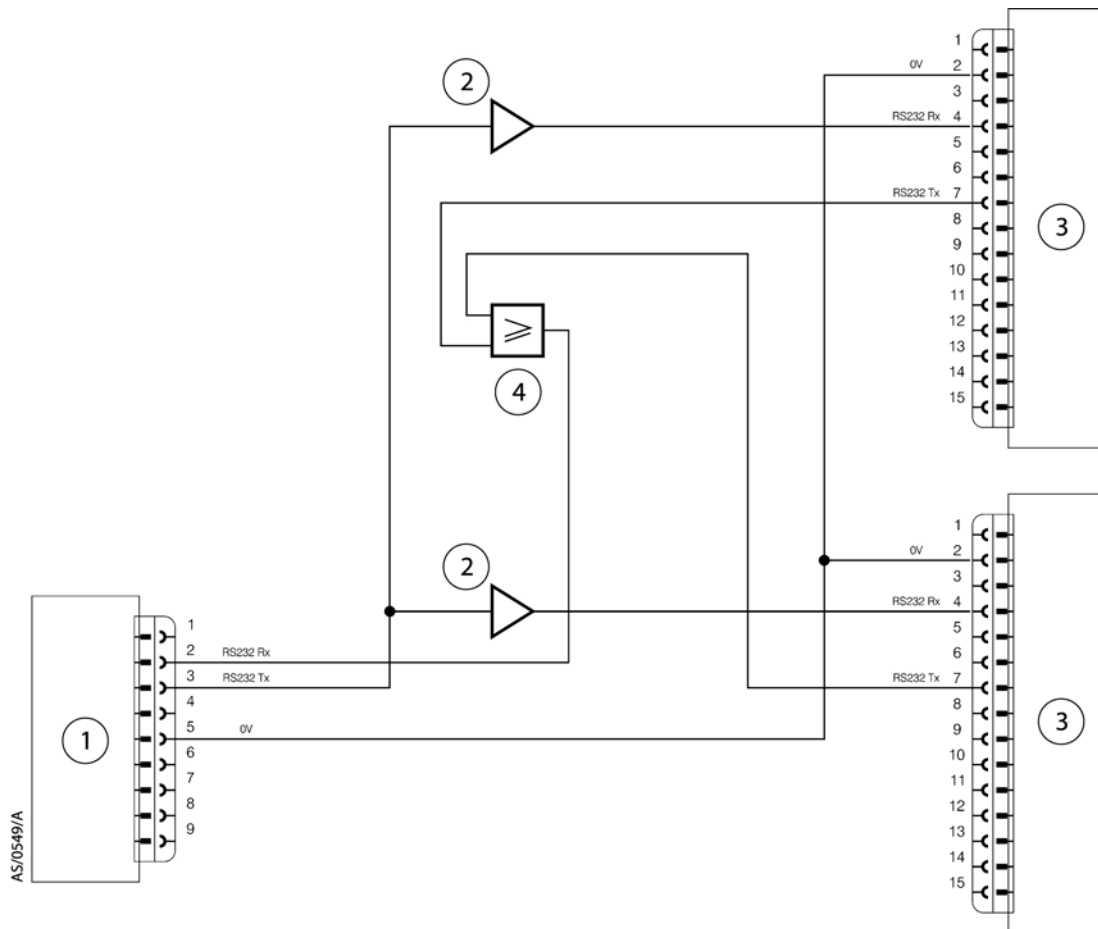

- | | |
|---|------------|
| 1. RS232 interface on control equipment | 3. DX pump |
| 2. Buffer | 4. OR gate |

3.7.4 Message structure

To communicate a message to the DX pump you must send the characters in a specific order. If the message does not conform to the correct structure it will be ignored and no reply will be sent.

The correct structure to use is as follows:

- a valid start character, either a '!' character for a store operation or a '?' character for a query operation, followed by
- a command, which will be an upper case alphabetical character, followed by
- an object number, comprising three decimal digits, followed by
- for some commands only, a data field, comprising a sequence of characters separated from the object number by a space, followed by
- a terminating carriage return

The message protocol in multi-drop mode is marginally different, refer to [Section 3.7.7](#).

3.7.5 Command set

Table 15 shows a summary of the full set of commands available for controlling and monitoring the DX pump.

Table 16 shows the abbreviations that are used to define commands in the following sections and Table 17 shows the error codes that might be returned.

3.7.6 Simultaneous parallel and serial operation

You can control the pump using Parallel Interface control inputs and at the same time monitor various pump parameters using the Serial Interface. Alternatively you can control the pump using commands sent over the Serial Interface while at the same time you can monitor the Normal signal and Analogue Output over the Parallel Interface. Figure 11 shows a schematic diagram of a system that would allow you to do this.

You cannot control the pump using both the Parallel and Serial Interfaces simultaneously. For example, if you start the pump by sending a Start command over the Serial Interface you cannot then stop the pump by using the Start / Stop switch on the Parallel Interface. The pump will ignore the state of the Start / Stop switch on the Parallel Interface. To stop the pump you must send a Serial Stop command. Only when the Serial Stop command has been received by the pump can any commands sent via the Parallel Interface be acted on.

Similarly, if you Start the pump by using the Start switch on the Parallel Interface you cannot then stop the pump by sending a Stop command over the Serial Interface. The pump will ignore any Start or Stop commands received over the Serial Interface. To stop the pump, you must use the Parallel Stop switch. Only when the pump has been stopped using the Parallel Interface switch will any Start or Stop commands be accepted via the Serial Interface.

Table 15 - Summary of commands that can be sent to the DX pump

Object name	Command	Parameter range	Factory setting	Data type	Units	Comments
Node	!S850 ?S850	0.99	-	decimal	address	Multi-drop address 0 = disable multi-drop address 99 = wildcard
Pump type	?S851	7; 10; 4	-	string string string	chars chars chars	Pump type DSP software version number (D39647631x for EXT75DX) and D39648601x for EXT255DX) Full speed RPS (1500 for EXT75DX and 1000 for EXT255DX)
Pump control	!C852 ?V852	0 1 0.1800; 32-bits	- -	decimal decimal hex	- RPS flags	Stop the pump Start the pump Measured motor speed System status word
Vent options	!S853 ?S853	0 1 2 3 4 5 6 7 8	0	decimal		Hard vent only when <50% speed Controlled vent if >50% speed or hard vent if <50% speed Hard vent if stop or hard vent if fail and <50% speed Hard vent if stop or controlled vent if fail and >50% speed or hard vent if fail and <50% speed Hard vent if fail or hard vent if stop and <50% speed Hard vent if fail or controlled vent if stop and >50% speed or hard vent if stop and <50% speed Hard vent if stop or fail Same as option 6 Vent = Permanently Enabled (Fan)

Table 15 - Summary of commands that can be sent to the DX pump (continued)

Object name	Command	Parameter range	Factory setting	Data type	Units	Comments
Timer setting	!S854 ?S854	1.30	8	decimal	minutes	Timeout period for both initial ramp up and if speed drops below 50%
Power limit setting	!S855	50.120	80	decimal	watts	Link power maximum EXT75DX
	?S855	80.200	160	decimal	watts	Link power maximum EXT255DX
Normal speed setting	!S856 ?S856	50.100	80	decimal	%	Normal speed as a percentage of full speed
Standby speed setting	!S857 ?S857	55.100	70	decimal	%	Standby speed as a percentage of full speed
Temperature readings	?V859	0.100;	-	decimal	°C	Measured motor temperature
		0.100	-	decimal	°C	Measured controller temperature
Link parameter readings	?V860	0.500;	-	decimal	0.1volts	Measured link voltage
		0.300;	-	decimal	0.1amps	Measured link current
		0.15000	-	decimal	0.1watts	Measured link power
Factory settings	!S867	1	-	-	-	Reset all configuration options and parameters to the factory settings
PIC software version	?S868	10	-	string	chars	PIC software version number (D39647620x)
Speed control	!C869	0	-	decimal	-	Set target speed to full speed
		1	-	decimal	-	Set target speed to standby speed
Timer options	!S870 ?S870	0	1	decimal	-	Timer = disabled
		1	1	decimal	-	Timer = enabled Note that the timer is permanently enabled on ramp-up.
Analogue signal options	!S871 ?S871	0	0	decimal	-	Analogue output = Measured speed
		1	0	decimal	-	Analogue output = Measured power
		2	0	decimal	-	Analogue output = Measured motor temp.
		3	0	decimal	-	Analogue output = measured control temp.
Electronic braking option	!S872 ?S872	0	0	decimal	-	Electronic braking = disabled
		1	0	decimal	-	Electronic braking = enabled
Close vent valve	!C875	1	-	decimal	-	Closes the vent valve for delayed start and overrides the current vent option. There is no open vent valve command but the stop command (!C852 0) will clear the override.

Table 16 - Command abbreviations

Abbreviation	Meaning
cr	carriage return character
chars	characters
d	decimal ASCII character
	<i>Note: Fields showing multiple d characters are to indicate typical length. All data fields have a maximum of 5 decimal characters (prefixed by a minus number for negative numbers).</i>
h	hexadecimal ASCII character
r	Returned error code - refer to Table 17
sp	space character
string	may have several ASCII characters
X	Multi-drop decimal ASCII character
	<i>Note: Fields showing multiple X characters are to indicate maximum length and not fixed length.</i>

Table 17 - Error codes

Returned error code	Meaning
0	No error
1	Invalid command for object ID
2	Invalid Query/Command
3	Missing parameter
4	Parameter out of range
5	Invalid command in current state - e.g. serial command to start/stop when in parallel control mode

Figure 11 - Schematic diagram of the logic interface connections

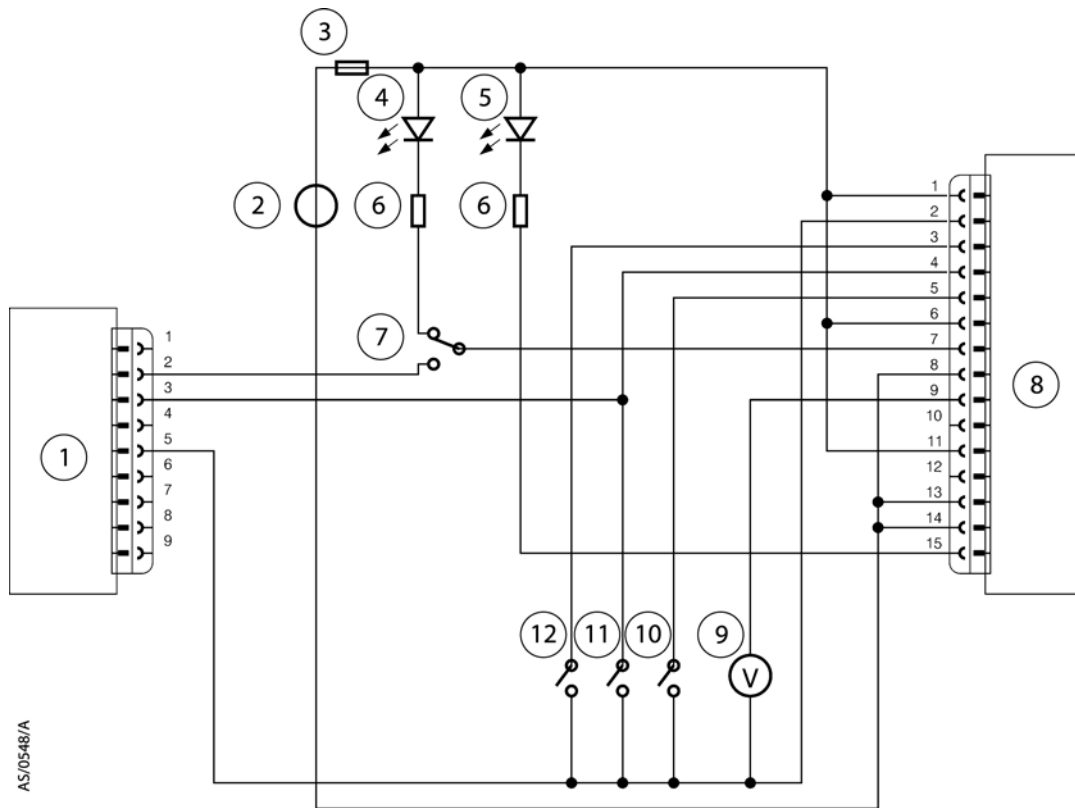

- | | |
|--|-----------------------------------|
| 1. RS232 interface on control equipment | 7. Optional serial mode selector |
| 2. 24 V d.c. electrical supply | 8. DX pump |
| 3. Fuse | 9. Optional voltmeter |
| 4. Optional LED indicator - system OK | 10. Optional serial enable switch |
| 5. Optional LED indicator - normal speed | 11. Optional standby switch |
| 6. Current limit resistor for LED | 12. Start switch |

3.7.7 Multi-drop mode

Using multi-drop mode, you can communicate with more than one DX pump using a single computer system. Each DX pump must be assigned its own individual address before it can be fitted into a multi-drop system. The command to assign the multi-drop address is sent in standard DX message format (as detailed in [Section 4.1.10](#)).

The message protocol in multi-drop mode is marginally different to that described for serial messages in single pump systems. The main differences in multi-drop message protocol are detailed below:

- All multi-drop commands, queries or replies have the first character #.
- All commands, queries and replies contain a header containing the address of the node that the message is to, followed by the address of the node that the message is from.
- There is a delimiter character: (colon) which separates the two multi-drop addresses in the header.
- The remainder of the message (command, query or reply) follows the same protocol as already described for single pump systems.
- The wild card address 99 is very useful and means 'any' node.

After a DX pump has been assigned a multi-drop address, it will ignore any messages in the format for single pumps. An individual DX pump will remain silent and ignore all command messages unless the multi-drop address matches its own address.

3.8 Vent options, vent valve connection and control

CAUTION

If the pump is vented when it is at full rotational speed and the rate of pressure rise is too high, the pump could be damaged and its life may be reduced. We therefore recommend that either the rate of pressure rise is limited (refer to [Figure 3](#)) or that the vent valve is only opened after the DX pump speed has fallen to 50% of full rotational speed.

To maintain the cleanliness of your vacuum system, we recommend that, whenever you switch the pump off, you vent the pump (or vacuum system) when the speed of the DX pump is between full rotational speed and 50% of full rotational speed. Over this speed range, the rotor spins fast enough to suppress any backstreaming of hydrocarbon oil from your backing pump.

Do not connect the vent-valve to the backing pipeline, this may lead to contamination. Connect the inlet of the vent-valve to the vent gas supply (refer to [Section 2.3](#) for the vent gas specification).

Venting may be accomplished by using one of the following methods described in [Section 3.8.1](#) to [3.8.4](#).

3.8.1 Manual vent valve

A manual vent-valve is supplied with the DX pump. It is not possible to accurately control the rate of pressure rise using the manual vent valve so take care not to open it too quickly. We recommend that you open the manual vent-valve only after the pump speed has fallen to 50% of full rotational speed.

3.8.2 TAV5 or TAV6 solenoid vent valve

The TAV5 and TAV6 solenoid valves can be purchased as accessories - see [Section 7.4](#). The solenoid valves can be used in the following ways:

- Use a TAV5 or TAV6 solenoid valve in place of the manual vent valve on the pump
- Use a TAV5 or TAV6 solenoid valve connected to a convenient flange on your vacuum system

If you connect a vent valve to your vacuum system, select a point upstream of the DX pump to prevent backstreaming of oil from the backing pump.

If using the TAV5 vent-valve, the pump may only be hard vented when it is at full speed if the vacuum system has a volume of 5 litres or more. If using the TAV6 vent-valve, the pump may only be hard vented when it is at full speed if the vacuum system has a volume of 10 litres or more.

If the volume of your vacuum system is less than 5 litres (when using a TAV5 vent-valve), or if the volume of your vacuum system is less than 10 litres (when using a TAV6 vent-valve), you can incorporate a suitable vent-restrictor and vent the pump when it is at full speed. [Table 19](#) gives an indication of the appropriate orifice size to be fitted to the vent valve for given vacuum system volumes in order that the rate of pressure rise remains within the limits shown in [Figure 3](#).

Note: *If you use a vent-restrictor, you may find that the time required to vent your vacuum system is unacceptably long. You may be able to reduce the vent time if you use a vent-valve without a vent-restrictor and wait until the pump speed has fallen to 50% of full rotational speed before you open the vent-valve.*

3.8.3 Controlled venting

The TAV5 or TAV6 solenoid valve can be controlled by the Podule electronics. To use this function, fit the electrical connector supplied with the pump to the lead of the TAV5 or TAV6 solenoid valve. To ensure cable cores and screen are wired correctly, follow the electrical connection instructions given in the Accessories Manual (supplied with the TAV valve) and refer to [Figure 4](#) and [Section 2.9](#). Plug the connector into the socket at the top of the Podule (refer to [Figure 1](#) and [2](#), items 1 and 7 respectively).

The Podule is capable of controlling a number of different venting options, these are defined in [Table 18](#).

Table 18 - Vent options

Option number	Description of vent function
0	Vent valve opens fully below 50% full rotational speed for either Stop command or Fail. <i>Note: This is the factory default setting.</i>
1	Controlled venting from 100% to 50% full rotational speed; vent valve opens fully below 50% for either Stop command or Fail.
2	Vent valve fully opens immediately Stop command is received; vent valve opens fully below 50% full rotational speed if Fail.
3	Vent valve fully opens immediately Stop command is received; controlled venting from 100% to 50% full rotational speed if Fail then vent valve opens fully below 50%.
4	Vent valve fully opens immediately if Fail; vent valve opens fully below 50% full rotational speed if Stop.
5	Vent valve fully opens immediately if Fail; controlled venting from 100% to 50% full rotational speed if Stop command received then vent valve opens fully below 50%.
6.7	Vent valve fully opens immediately for either Stop command or Fail.

When you receive your pump, the Podule will be configured with the factory default vent option 0, as detailed in [Table 18](#). You can configure your Podule to one of the other venting options provided you can send commands via the Serial Interface or you have access to an Edwards TIC Turbo and Instrument Controller or Turbo Controller.

The Podule only energises ('shuts') the TAV solenoid valve when it receives a Start command. Prior to that, the valve will be in the 'open' vent state. If you have a large vacuum system, you may wish to allow the backing-pump to reduce the pressure in the system to an acceptable level before starting the DX pump. In this case, you can send a command via the Serial Interface to close the vent valve before you send a Start command - this is known as a delayed start.

If you are controlling your DX pump with an Edwards TIC Turbo and Instrument Controller or TIC Turbo Controller, you can drive your TAV solenoid valve from the TIC. Refer to the TIC Instruction Manuals for more information.

3.8.4 Alternative valve connected to the vacuum system

If using another vent-valve, ensure that a suitable vent-restrictor is fitted to your vacuum system to limit the rate of pressure rise. Refer to [Table 19](#) for information about vent-restrictor sizes. If you do not fit a suitable vent-restrictor, you must open the vent-valve only after the speed of the pump has fallen to 50% of full rotational speed.

Table 19 - Vent-restrictor orifice diameter (with atmospheric pressure at the inlet of the vent-valve)

Vacuum system volume (litres)	Orifice diameter (mm)
<20	≤1.0
<10	≤0.7
<5	≤0.5
<2	≤0.35

3.9 Cooling

3.9.1 Introduction

CAUTION

You must ensure that the pump is adequately cooled to prevent damage to the rotor and bearing.

- **Natural Convection Cooling:** For some light pumping duties, with an ambient air temperature less than 30 °C, natural convection cooling may be adequate to cool the DX pump.
- **Forced Air Cooling:** The ambient air temperature when using forced air cooling must be 5 °C to 35 °C. You must ensure that there is an adequate supply of cooling-air to the pump.
- **Water-Cooling:** You must use water-cooling with an ambient air temperature greater than 35 °C or when using a bakeout band (CF variants only). When using water-cooling, ambient air temperature must be less than 40 °C and the water temperature must be between 10 °C and 20 °C.
- We recommend that wherever possible, you cool the pump by forced air cooling or water-cooling. See [Table 5](#), [page 10](#) for further performance information.

3.9.2 Forced air cooling

Air-cooling accessories are available for DX pumps (refer to [Section 7.4](#)). Fit the air-cooler as described in the instruction manual supplied with it. If you wish to use an alternative fan for air-cooling, ensure that the flow rate is above 70 m³h⁻¹ (40 cfm).

The air-cooler can be powered by your own external power supply, the Edwards TIC Turbo and Instrument Controller, the TIC Turbo Controller or by the Podule. It cannot be powered by the Podule if a TAV solenoid valve is already connected to the Podule. Follow the electrical connection instructions in the air-cooler manual to wire the lead of the air-cooler into the Podule connector supplied with the pump (refer to [Figure 1](#)). Plug the connector into the socket at the top of the Podule (refer to [Figure 1](#) and [2](#), items 1 and 7 respectively).

You can only configure your Podule to drive an air-cooler if you can send commands via the Serial Interface or you have access to an Edwards TIC Turbo and Instrument Controller or Turbo Controller.

3.9.3 Water-cooling

CAUTION

You must turn off the cooling-water when you switch off the pump to prevent condensation inside the pump and Podule.

A WCX water-cooler accessory is available for the DX pumps (refer to [Section 7.4](#)). Apply a thin layer of thermal grease to the mounting face of the water-cooler then fit it as described in the instruction manual supplied with it. The cooling-water supply must comply with the specification given in [Section 2.5](#). Pipes in the water-cooling circuit may become blocked if the cooling-water contains too much calcium carbonate or if it contains particles that are too large. Corrosion of the water-cooling circuit may occur if there is too little calcium carbonate and oxygen in the water. Good quality drinking water is usually suitable. If in doubt, check the quality of your cooling-water supply and, if necessary, provide treatment and filtration.

Connect the cooling-water supply to the water-cooler on the pump as described below. Either of the two ruffled connectors on the water-cooler can be used for the water supply or return connections.

Push reinforced hose (approximately 6 mm internal diameter) over the ends of the ruffled hose connectors on the water-cooler on the pump. Attach the hose with strong hose clips and make sure that they are tightened securely. Alternatively, unscrew the ruffled hose connectors and remove them from the water-cooler and make direct connections to the 1/8 inch BSP female threaded fittings on the water-cooler.

If you want to remove the pump for maintenance, and you do not want to break the cooling-water circuit, unscrew the two M4 fixing-screws and remove the water-cooler from the pump. Make sure that there is a layer of thermal contact grease on the water-cooler before you refit it to the pump.

This page has been intentionally left blank.

4 Operation



WARNING

Do not operate the DX pump unless it is connected to your vacuum system. If you do, the pump rotor can cause injury. The pump rotor rotates at very high speeds and the rotating blades might not be visible.

Before operating the pump, it is worthwhile configuring the various Podule settings so that they are suitable for your application.

If your system is designed to operate in pure Parallel Interface Mode, you will not have the facility to change any of the Podule settings once the DX pump is installed on your system. The pump is supplied with all settings at factory default values, as shown in [Table 15](#). If you wish to change any of the Podule settings, make sure you do this separately before installing the DX pump on your system.

To configure the DX pump you could use your own serial system. [Section 4.1](#) details the commands that you will need to configure the Podule. Alternatively you could use the Edwards TIC Turbo and Instrument Controller or TIC Turbo Controller. Further information regarding this is detailed in [Section 4.2](#).

If you intend to operate the DX pump in pure Parallel Interface Mode and you do not wish to reconfigure the Podule settings, go straight to [Section 4.3](#).

4.1 Configuring the DX pump using serial commands

Refer to [Table 15](#) for a summary of the full set of serial commands. [Table 13](#) details the parameter range and factory default for each setting. The following sections describe the settings in more detail.

4.1.1 Power limit setting

[Table 20](#) shows the power limit setting options for the DX pumps. The pump is supplied to you with a default power limit as shown. If this limit is not suitable for your application, you can change it to any value between the maximum and minimum shown.

Table 20 - Power limit setting

Pump	Maximum value setting	Minimum value setting	Default power setting
EXT75DX	120 W	50 W	80 W
EXT255DX	200 W	80 W	160 W

Send the command as follows (where the 'd' characters represent the value in Watts that you are trying to set. For example, if you want to set the limit to 90 W, type 90).

Command	!	S	8	5	5	sp	d	d	d	cr
---------	---	---	---	---	---	----	---	---	---	----

The reply you receive will be in the following format:

Reply	*	S	8	5	5	sp	r	cr
-------	---	---	---	---	---	----	---	----

The Power Limit Setting is now stored in memory within the DX pump.

To check what power limit is set, you can send a query as follows:

Command	?	S	8	5	5	cr
---------	---	---	---	---	---	----

The reply you receive will be in the following format:

Reply	=	S	8	5	5	sp	d	d	d	cr
-------	---	---	---	---	---	----	---	---	---	----

4.1.2 Powering a fan from the podule

You can power a fan from the DX Podule, provided that you are not already using the Podule to control a vent valve.

To enable the fan, send the following command:

Command	!	S	8	5	3	sp	8	cr
---------	---	---	---	---	---	----	---	----

The reply you receive will be in the following format:

Reply	*	S	8	5	3	sp	r	cr
-------	---	---	---	---	---	----	---	----

The permanently enabled fan setting is now stored in memory within the DX pump.

When you receive the pump, it will be set-up to run a vent valve. You can send a query to find out what the setting is as follows:

Command	?	S	8	5	3	cr
---------	---	---	---	---	---	----

The reply you receive will be in the following format:

Reply	=	S	8	5	3	sp	d	cr
-------	---	---	---	---	---	----	---	----

If the character 'd' is 8, then the fan is enabled. If it is anything else, you will need to configure the Podule to run the fan.

4.1.3 Controlled venting options

If you are using the Podule to automatically control a vent valve, there are a number of varied venting options you can choose from, refer to [Table 18](#).

To set a vent option, send the following command, (where the character 'd' refers to the option number shown in [Table 18](#)):

Command	!	S	8	5	3	sp	d	cr
---------	---	---	---	---	---	----	---	----

The reply you receive will be in the following format:

Reply	*	S	8	5	3	sp	r	cr
-------	---	---	---	---	---	----	---	----

The Venting Option is now stored in memory within the DX pump.

To check what Venting Option is set, you can send a query as follows:

Command	?	S	8	5	3	cr
---------	---	---	---	---	---	----

The reply you receive will be in the following format:

Reply	=	S	8	5	3	sp	d	cr
-------	---	---	---	---	---	----	---	----

4.1.4 Standby speed setting

The pump can be run at Standby Speed rather than full rotational speed. The Standby Speed is a user configurable option and can be set to any value between 55% and 100% full rotational speed. When you receive the pump, it will be configured with a standby speed of 70% full rotational speed.

To change the Standby Speed setting, send the following command (where the characters 'd' represent the value as a percentage of full rotational speed):

Command	!	S	8	5	7	sp	d	d	d	cr
---------	---	---	---	---	---	----	---	---	---	----

The reply you receive will be in the following format:

Reply	*	S	8	5	7	sp	r	cr
-------	---	---	---	---	---	----	---	----

The Standby Speed is now stored in memory within the DX pump.

To check what Standby Speed is set, you can send a query as follows:

Command	?	S	8	5	7	cr
---------	---	---	---	---	---	----

The reply you receive will be as follows:

Reply	=	S	8	5	7	sp	d	d	d	cr
-------	---	---	---	---	---	----	---	---	---	----

4.1.5 Normal speed setting

The Normal Speed is a user-configurable setting and can be set to any value between 50% and 100% full rotational speed. When you receive the pump, it will be configured with a Normal speed of 80% full rotational speed.

To change the Normal Speed setting, send the following command (where the characters 'd' represent the value as a percentage of full rotational speed):

Command	!	S	8	5	6	sp	d	d	d	cr
---------	---	---	---	---	---	----	---	---	---	----

The reply you receive will be as follows:

Command	*	S	8	5	6	sp	r	cr
---------	---	---	---	---	---	----	---	----

The Normal Speed is now stored in memory within the DX pump.

To check what Normal Speed is set, you can send a query as follows:

Command	?	S	8	5	6	cr
---------	---	---	---	---	---	----

The reply you receive will be as follows:

Reply	=	S	8	5	6	sp	d	d	d	cr
-------	---	---	---	---	---	----	---	---	---	----

4.1.6 Timer setting and options

Refer to Section 1.4.3 for a full description of Timer functionality.

The timeout period is a user-configurable option and can be set to any value from 1 to 30 minutes. When you receive the pump, it will be configured with a default timeout period of 8 minutes.

To change the Timer setting, send the following command (where the characters 'd' represent the timeout period in minutes):

<i>Command</i>	!	S	8	5	4	sp	d	d	cr
----------------	---	---	---	---	---	----	---	---	----

The reply you receive will be as follows:

<i>Reply</i>	*	S	8	5	4	sp	r	cr
--------------	---	---	---	---	---	----	---	----

The Timer setting is now stored in memory within the DX pump.

To check what timeout period is set, you can send a query as follows:

<i>Command</i>	?	S	8	5	4	cr
----------------	---	---	---	---	---	----

The reply you receive will be as follows:

<i>Reply</i>	=	S	8	5	4	sp	d	d	cr
--------------	---	---	---	---	---	----	---	---	----

The Timer is permanently enabled during ramp-up, however it is optional whether you have it enabled at other times. When you receive the pump, it will have the Timer enabled by default.

If you wish to disable the Timer, send the following serial command:

<i>Command</i>	!	S	8	7	0	sp	0	cr
----------------	---	---	---	---	---	----	---	----

The reply you receive will be as follows:

<i>Reply</i>	*	S	8	7	0	sp	r	cr
--------------	---	---	---	---	---	----	---	----

The state of the Timer option is stored in memory within the DX pump.

To enable the Timer again, send the following serial command:

<i>Command</i>	!	S	8	7	0	sp	1	cr
----------------	---	---	---	---	---	----	---	----

The reply you receive will be as follows:

<i>Reply</i>	*	S	8	7	0	sp	r	cr
--------------	---	---	---	---	---	----	---	----

To check whether the Timer is enabled or disabled, send the following query:

<i>Command</i>	?	S	8	7	0	cr
----------------	---	---	---	---	---	----

The reply you receive will be as follows (where d=0 means disabled and d=1 means enabled):

<i>Reply</i>	=	S	8	7	0	sp	d	cr
--------------	---	---	---	---	---	----	---	----

4.1.7 Analogue signal options

The Analogue Output can be used to monitor one of four different parameters, as detailed in Table 21.

Table 21 - Analogue signal options

Option number	Description of analogue output number
0	Measured pump rotational speed <i>Note: This is the factory default setting.</i>
1	Measured system power
2	Measured motor temperature
3	Measured controller temperature

To configure the Analogue Output, send the following command (where the character 'd' denotes the option number detailed in Table 21):

Command	!	S	8	7	1	sp	d	cr
---------	---	---	---	---	---	----	---	----

The reply you receive will be as follows:

Reply	*	S	8	7	1	sp	d	cr
-------	---	---	---	---	---	----	---	----

The Analogue Output Signal setting is now stored in memory within the DX pump.

To check which Analogue Output Signal setting is enabled, you can send a query as follows:

Command	?	S	8	7	1	cr
---------	---	---	---	---	---	----

The reply you receive will be as follows:

Reply	=	S	8	7	1	sp	d	cr
-------	---	---	---	---	---	----	---	----

4.1.8 Electronic braking options

Refer to Section 1.4.7 for a full description of the Electronic Braking feature. The pump is supplied with Electronic Braking disabled by default. To enable Electronic Braking, send the following serial command:

Command	!	S	8	7	2	sp	1	cr
---------	---	---	---	---	---	----	---	----

The reply you receive will be as follows:

Reply	*	S	8	7	2	sp	r	cr
-------	---	---	---	---	---	----	---	----

The state of the Electronic Braking option is stored in memory within the DX pump.

To disable the Electronic Braking again, send the following serial command:

Command	!	S	8	7	2	sp	0	cr
---------	---	---	---	---	---	----	---	----

The reply you receive will be as follows:

Reply	!	S	8	7	2	sp	r	cr
-------	---	---	---	---	---	----	---	----

To check whether Electronic Braking is enabled or disabled, send the following query:

Command	?	S	8	7	2	cr
---------	---	---	---	---	---	----

The reply you receive will be as follows (where d=0 means disabled and d=1 means enabled):

Reply	=	S	8	7	2	sp	d	cr
-------	---	---	---	---	---	----	---	----

4.1.9 Factory settings

You can re-configure your DX pump back to its original factory settings with one serial command.

To reset the Podule to factory settings, send the following command:

Command	*	S	8	6	7	sp	1	cr
---------	---	---	---	---	---	----	---	----

The reply you receive will be as follows:

Reply	*	S	8	6	7	sp	r	cr
-------	---	---	---	---	---	----	---	----

The factory settings are restored in the memory within the DX pump.

4.1.10 Assigning a multi-drop address

When you receive your DX pump it will have multi-drop mode disabled by default. Each individual pump must be programmed with its own multi-drop address via a point-to-point connection before introduction into a multi-drop network.

Send the following command to assign a multi-drop address (where the 'd' characters represent the address):

Command	!	S	8	5	0	sp	d	d	cr
---------	---	---	---	---	---	----	---	---	----

Note: The address can be any decimal number from 1 to 98. The address number 0 is used to disable multi-drop mode. The address number 99 is reserved as a wild card and is used in the query set up detailed later.

The reply you receive will be as follows:

Reply	*	S	8	5	0	sp	r	cr
-------	---	---	---	---	---	----	---	----

The multi-drop address is stored within the DX pump.

You can also send a query to the pump to find out whether it already has a multi-drop address. Send the following command:

Query	?	S	8	5	0	cr
-------	---	---	---	---	---	----

If you receive the reply shown below, your pump has multi-drop mode disabled:

Reply	=	S	8	5	0	sp	0	cr
-------	---	---	---	---	---	----	---	----

If your pump already has a multi-drop address you will receive no reply and you must then communicate with your pump in multi-drop message protocol. Refer to [Section 3.7.7](#) for more information about multi-drop mode and multi-drop message protocol.

Use the following query (using wild card address 99 which means 'any' node) to find out the multi-drop address of the DX pump:

Command	#	9	9	:	9	9	?	S	8	5	0	cr
---------	---	---	---	---	---	---	---	---	---	---	---	----

The reply you receive will be as follows, where dd denotes the multi-drop address of the pump:

Reply	#	9	9	:	9	9	=	S	8	5	0	sp	d	d	cr
-------	---	---	---	---	---	---	---	---	---	---	---	----	---	---	----

You can disable multi-drop mode by assigning the pump an address 0. To do this, send the following command (where dd denotes the multi-drop address of the pump and XX denotes the address of the node that is sending the command):

Command	#	d	d	:	x	x	!	S	8	5	0	sp	0	cr
---------	---	---	---	---	---	---	---	---	---	---	---	----	---	----

The reply you receive will be as follows:

Reply	#	x	x	:	d	d	*	S	8	5	0	sp	0	cr
-------	---	---	---	---	---	---	---	---	---	---	---	----	---	----

Once multi-drop mode is disabled, the pump will no longer respond to multi-drop commands.

4.2 Configuring the DX pump using a TIC

The DX pump can be configured using the Edwards TIC Turbo and Instrument Controller or TIC Turbo Controller.

It is possible to set the following parameters of the DX pump using the TIC:

- Power limit setting
- Controlled venting options, including running a fan from the Podule
- Standby speed setting
- Normal speed setting
- Timer settings - both enabling/disabling the timer AND setting the timeout period
- Electronic braking options
- factory default settings

For information on how to perform these settings, refer to the TIC Turbo and Instrument Controller or TIC Turbo Controller Instruction Manuals.

Note: *It is not possible to configure the Analogue Output Options using the TIC. There is also no facility within the TIC to assign a multi-drop address to the DX pump.*

There is a further option of connecting the TIC to a PC and using the TIC PC Program to configure the DX pump. The TIC PC Program allows you to configure all the settings shown in the list above as well as allowing configuration of the Analogue Output Options and assignment of a multi-drop address. Refer to the TIC PC Program Instruction Manual for more information.

4.3 Start-up

Irrespective of the system you use to control the DX pump, work through the following steps before starting the pump.

4.3.1 Close the vent valve

- If you are using a manual vent valve, turn it clockwise to close it.
- If you are using your own control system to drive a vent valve, make sure that the vent valve is closed.
- If you are driving a TAV solenoid valve from the Podule, the TAV valve will automatically shut when the pump is started.
- If you are using the TIC to operate the vent valve, refer to [Section 4.6](#).

Note: The backing pump and DX pump can be started at the same time, the DX pump will not be damaged and can operate as an effective baffle. However, if the vacuum system is large (100 litres or larger) it will be more efficient to allow the backing pump to reduce system pressure to 10 mbar before starting the DX pump. In this case it will be necessary to close the vent valve in advance of starting the backing pump.

If you are using the Podule to control a TAV solenoid valve but you are operating in pure Parallel Interface Mode, you will NOT be able to shut the valve in advance of starting the DX pump because you do not have the facility to send the appropriate serial command. If you have the facility to send serial commands you can perform a delayed start, refer to [Section 4.5.1](#).

Note: If you are using a diaphragm pump for backing the DX pump, allow a delay of 2 minutes before starting the DX pump.

4.3.2 Pre-start checks

1. Turn on the appropriate cooling device (fan or cooling-water supply).

Note: If you have configured the Podule to drive a fan, the fan will automatically start when power is supplied to the DX pump.

2. Start the backing pump.

3. Switch on the power supply to the pump. Check that the two LEDs on the Podule light up for approximately 0.5 seconds and then extinguish.

If the LEDs do not light up as expected, or if the yellow LED begins to flash, refer to [Section 5.5](#).

4.4 Operation with parallel control and monitoring

4.4.1 Start the pump

Start the DX pump by linking the Start/Stop control input to the 0 V control reference on the logic interface connector. The pump will then accelerate to full operating speed.

The green indicator on the Podule will illuminate when the pump reaches Normal speed (this is 80% of full rotational speed by default but you may have selected a different value to suit your application).

4.4.2 Running at standby speed

To run the DX pump at Standby Speed, link both the Standby control input to the 0 V control reference on the logic interface connector. If the pump is currently below Standby Speed then it will accelerate until it reaches Standby speed. If it is running faster than Standby Speed, it will decelerate until Standby Speed is reached.

To return the pump to full speed, disconnect the Standby control input from the 0 V control reference on the logic interface connector.

4.4.3 Stop the pump

Stop the DX pump by disconnecting the Start/Stop control input from the 0 V control reference on the logic interface connector. The pump rotor will decelerate to rest.

4.4.4 Parallel monitoring

It is possible to monitor the following parameters:

- Analogue output
- Normal signal
- Fail signal

Refer to [Section 3.6](#) for instructions on how to monitor these signals.

4.5 Operation with serial control and monitoring

4.5.1 Delayed start

If you are using a TAV solenoid valve controlled by the Podule, you may wish to close it before starting the DX pump. This will allow the backing pump to reduce the pressure in your vacuum system.

To close the vent valve, send the following command:

Command	!	c	8	7	5	sp	1	cr
---------	---	---	---	---	---	----	---	----

The reply you receive will be in the following format:

Reply	*	c	8	7	5	sp	r	cr
-------	---	---	---	---	---	----	---	----

Note: This command overrides the current vent option and closes the vent valve. There is no open vent valve command but when you send a stop command to the pump the override is cleared.

4.5.2 Start the pump

To start the pump, send the following command over the serial communications link:

Command	!	c	8	5	2	sp	1	cr
---------	---	---	---	---	---	----	---	----

The reply you receive will be in the following format:

Reply	*	c	8	5	2	sp	1	cr
-------	---	---	---	---	---	----	---	----

The pump will then accelerate to full operating speed. The green indicator LED will illuminate when the pump reaches Normal speed. (This is 80% of full rotational speed by default but you may have selected a different value to suit your application).

4.5.3 Standby speed

To run the DX pump at Standby Speed, send the following command over the serial communications link:

Command	!	c	8	6	9	sp	1	cr
---------	---	---	---	---	---	----	---	----

The reply you receive will be as follows:

Reply	*	c	8	6	9	sp	r	cr
-------	---	---	---	---	---	----	---	----

If the pump is currently below Standby Speed then it will accelerate until it reaches Standby Speed. If it is running faster than Standby Speed, it will decelerate until Standby Speed is reached.

To return the pump to full speed, send the following command:

Command	!	c	8	6	9	sp	0	cr
---------	---	---	---	---	---	----	---	----

The reply you receive will be as follows:

Reply	*	c	8	6	9	sp	r	cr
-------	---	---	---	---	---	----	---	----

4.5.4 Stop the pump

To stop the DX pump, send the following command over the serial communications link:

Command	!	c	8	5	2	sp	0	cr
---------	---	---	---	---	---	----	---	----

The reply you receive will be in the following format:

Reply	*	c	8	5	2	sp	r	cr
-------	---	---	---	---	---	----	---	----

On successful receipt of the stop command, the pump rotor will decelerate to rest.

4.5.5 Temperature readings

You can monitor the temperatures of both the pump motor and the internal electronics of the DX pump by sending the following query:

Command	?	v	8	5	9	cr
---------	---	---	---	---	---	----

The reply you receive will be as follows, where the first number is the motor temperature and the second number the internal Podule temperature, both measured in °C:

Reply	=	v	8	5	9	sp	d	d	d	;	d	d	d	cr
-------	---	---	---	---	---	----	---	---	---	---	---	---	---	----

4.5.6 Link parameter readings

You can monitor the internal voltage, current and motor power of the DX pump by sending the following query:

Command	?	v	8	6	0	cr
---------	---	---	---	---	---	----

You will receive the following reply, where the first number refers to voltage (measured in 0.1 Volts - i.e. divide the number by 10 to get an answer in Volts), the second number refers to current (measured in 0.1 Amps) and the third number refers to motor power (measured in 0.1 Watts):

Reply	=	v	8	6	0	sp	d	d	d	;	d	d	d	;	d	d	d	d	d	cr
-------	---	---	---	---	---	----	---	---	---	---	---	---	---	---	---	---	---	---	---	----

4.5.7 Measured motor speed

You can monitor the measured rotational speed of the motor inside the DX pump by sending the following query:

Command	?	v	8	5	2	cr
---------	---	---	---	---	---	----

You will receive the following reply, where the first returned number refers to motor rotational speed in revolutions per second (Hz):

Reply	=	v	8	5	2	sp	d	d	d	d	;	h	h	h	h	h	h	h	h	cr
-------	---	---	---	---	---	----	---	---	---	---	---	---	---	---	---	---	---	---	---	----

Note: The second return number is a 32-bit System Status Word (set of 8 hexadecimal characters) which is useful for fault-finding. Refer to [Section 4.5.2](#) for advice on decoding the System Status Word.

4.6 Simultaneous parallel and serial operation

Note: It is not possible to use serial interface monitoring at the same time as running the pump at Standby Speed in Parallel Interface Mode because the two functions share the same logic interface pins.

The Analogue Output signals are always available irrespective of whether you send commands in parallel or serial control mode. The Analogue Output voltages are described in [Table 9](#).

4.7 Operation with a TIC

For operation with an Edwards Turbo Instrument Controller or TIC Turbo Controller, the DX pump can be connected directly to this type of unit, which will provide the power necessary to drive the DX pump. Instructions on the set up and operation with the TIC or TIC Turbo Controller can be found on CD ROM part number D397-00-879 which is supplied with the TIC or TIC Turbo Controller.

4.8 Decelerating and venting

Immediately after applying the stop command, whether by the parallel or serial interface or by the TIC, switch off the backing-pump. Then vent the pump in accordance with the advice given in [Section 3.8](#).

CAUTION

Do not open a manual vent valve until the pump rotational speed has fallen below 50%, otherwise the rate of pressure rise may be too high, which could damage the pump. In an emergency only, open the vent-valve quickly to decelerate the pump rotor in the shortest possible time.

Note: If you are using the Podule to control a TAV solenoid valve, there is a 2-second delay between either a Stop command being received or a fault condition being detected and the vent valve opening. This delay allows time for gauges, valves and other equipment to be switched off before venting occurs.

The green indicator LED on the Podule will extinguish as rotational speed drops below Normal speed. At very low speeds you will see the yellow indicator LED flashing - it will extinguish when the pump has stopped.

The deceleration time can be improved by using the Electronic Braking feature, refer to [Section 4.5.4](#).

4.9 Operation at extreme conditions

4.9.1 Operation with high inlet pressure

If the DX pump inlet pressure rises, the power supplied to the pump-motor will increase to counteract the gas frictional load. The pump rotational speed will remain constant until the peak power level is reached; beyond this level, the speed of the pump will start to reduce.

If the pump speed falls to below 50% of full rotational speed, the Timer will start if it is enabled. If the speed does not recover to above 50% speed before the timeout period expires, the pump will shut down and display a Fail signal. If the Timer is disabled, the pump will immediately shutdown and display a Fail signal if the speed drops below 50% of full rotational speed. Refer to [Section 2.7](#) for the maximum power delivered to the pump and to [Table 5](#), for maximum allowable inlet pressure.

4.9.2 Operation at high temperatures

Temperature sensors within the pump mechanism and electronics are monitored by an internal system. If the system detects that any internal temperatures are too high, the power supplied to the pump-motor is reduced; the pump may not therefore be able to maintain full rotational speed if it is too hot.

If the pump speed falls to below 50% of full rotational speed, the Timer will start if it is enabled. If the speed does not recover to above 50% speed before the timeout period expires, the pump will shut down and display a Fail signal. If the Timer is disabled, the pump will immediately shutdown and display a Fail signal if the speed drops below 50% of full rotational speed. Refer to [Section 2.11](#) for pump operating ranges and [Section 3.9](#) for advice on pump-cooling.

4.9.3 Operation at over-speed

Control software within the Podule regulates the pump rotational speed and prevents the pump operating above its normal full rotational speed. In the unlikely event of a failure of this control software, the Podule has a built-in safety circuit that checks whether the pump is running at over-speed. If an over-speed condition is detected, the Podule automatically shuts down power to the pump-motor and slows it down to rest. The Podule will signal a Fail condition if over-speed has been detected.

If you suspect that your pump may be running at over-speed you should switch it off and consult Edwards or your supplier.

4.9.4 Electrical supply failure



WARNING

If the power supply fails when the pump is running, the impeller could continue to spin for approximately 10 minutes. The control circuit may not give any indication that the impeller is still running.



WARNING

If the parallel start control signal on the logic interface connector is set to start, the pump may automatically restart when the electrical supply is restored after an electrical supply failure. Ensure that people cannot be injured by the rotating blades of the pump.

CAUTION

If you are using a vent valve powered by the pump you must ensure that no more than 2 A is drawn from the regenerated power supply. If higher currents are drawn the voltage of the regenerated power supply may collapse causing the vent valve to open before the speed falls through 50% of full operating speed.

If the electrical supply to the DX pump fails when the pump is rotating, the motor of the pump is used as a generator. The regenerated power is used to maintain the output signals on the logic interface (such as the Normal signal and serial communications), to power the two indicator LEDs on the Podule and to maintain power at the Podule output (to control the vent valve, if fitted). The regenerated power is also available at the power supply pins of the logic interface connector and could be used to power other instruments through short power interruptions. The minimum voltage of this supply will be 24 V -20% (19.2 V) provided that the external load is not excessive.

As the pump rotational speed decreases, the motor's ability to generate power also decreases until it is no longer able to maintain power to the logic interface or LEDs. This will occur at speeds below 50% full rotational speed. Therefore you will not have any indication about pump rotational speed, yet the impeller may still be turning.

When the power is reinstated after a power failure, the behaviour of the pump will depend on the control mode at the time of failure (parallel or serial) and the length of time the pump was without power. [Table 22](#) shows a number of scenarios.

4.10 Bakeout



WARNING

Do not touch the bakeout band or surrounding surfaces during the bakeout process as they will be hot.

CAUTION

Pumps with ISO and NW style inlet-flanges are not suitable for bakeout, only pumps with CF flanges must be used. When baking the pump to above 70 °C at the inlet-flange, the pump must be water-cooled to prevent damage to the bearing lubricant.

If you heat your pump (and your vacuum system), you will speed up the degassing process so that the pump will reach ultimate vacuum in the shortest possible time. If you heat the pump, this will also prevent condensation of vapours inside the pump.

The Edwards BX bakeout band may be used to heat the pump (refer to [Section 7.4](#)). Fit the appropriate band around the pump, just below the CF inlet-flange. When baking the pump or the system, make sure that the temperature of the inlet-flange does not exceed 100 °C.

When baking your vacuum system, if the temperature of the system exceeds 200 °C, you must put a radiation shield between the system and the pump. This radiation shield will reduce the heat radiated onto the pump rotor.

Typically, a bakeout of four hours is long enough to remove water condensation from the pump. However, the bakeout time will depend on the amount of condensation in the pump and the vacuum system, and the ultimate pressure you want to achieve.

Table 22 - Behaviour of a pump when the power is re-instated after an electrical supply failure

Length of power failure	Control mode	Behaviour of pump
Power is reinstated before pump rotational speed falls below 50%	Either Parallel or Serial Control	Regenerative power maintains all output signals during the power failure. The pump will ramp to its designated speed as quickly as possible after the power has been restored.
Power is reinstated after pump rotational speed falls below 50% but before regenerative power ceases	Either Parallel or Serial Control, Timer disabled	Regenerative power maintains all output signals during the power failure. As the Timer is disabled, the Podule will go into fail condition as soon as speed falls below 50% and will display flashing error code 0. When the power is reinstated, the pump will not ramp up until the error is cleared. To clear the error, send a Stop command (either parallel or serial, depending on the control mode). Then send a Start command to ramp the pump up to designated speed.
	Either Parallel or Serial Control, Timer enabled	Regenerative power maintains all output signals during the power failure. If power is reinstated before the Timer period expires, the pump will ramp up to its designated speed as quickly as possible. If the Timer period expires, the Podule will go into Fail condition and will display flashing error code 3. As above, when the power is reinstated, the pump will not ramp up until the error is cleared. To clear the error, send a Stop command (either parallel or serial, depending on the control mode). Then send a Start command to ramp the pump up to designated speed.
Power is reinstated after pump rotational speed falls below 50% and the regenerative power ceases	Either Parallel or Serial Control	Regenerative power ceases and fails to maintain output signals. When power is reinstated, the pump with parallel control will automatically restart if the Start control on the logic interface is set to Start. The pump with serial control will require a Start command to ramp the pump up to the designated speed. Any Fail signals that were triggered during the regenerative power period are lost when the power is reinstated.

5 Maintenance



WARNING

The DX pump is not to be serviced by the customer. Pumps requiring servicing should be returned to Edwards or serviced by a qualified Edwards engineer.



WARNING

Allow the pump-rotor to stop, then disconnect the logic interface cable from the power supply before you remove the pump from your vacuum system for maintenance or fault finding procedures.

5.1 Introduction

Instructions for bearing maintenance and surface cleaning for the DX turbomolecular vacuum pump are described in the following sections. The inlet-screens, inlet-strainer and inlet-flange seals are available as spares (refer to Section 7.3). Fit the inlet-screen as described in Section 3.3.2.

5.2 Bearing maintenance

When supplied, the pump contains sufficient lubricant to supply the bearings for life. No routine maintenance is therefore required between bearing replacements. The bearings are not user-serviceable. The bearings will need to be replaced when they reach the end of their service life. This is typically more than 20,000 hours, but may be less; this depends on the type of pumping duty for which the pump is to be used.

When the bearings need replacement, we recommend that you exchange your pump for a factory reconditioned replacement. Alternatively, you can send your pump to an Edwards Service Centre to have the bearings replaced.

5.3 Rotor life

The fatigue life of EXT Turbo-pump rotors is typically 40,000 to 50,000 cycles. As a precautionary measure, Edwards recommends that pumps are returned for a major service (rotor replacement) after 20,000 cycles of acceleration to full speed and back to a stop, or after ten years of use, whichever occurs first.

5.4 Clean the external surfaces of the pump



WARNING

Clean the external surfaces of the pump in a well-ventilated location. When you use cleaning solutions and solvents to clean the pump, observe all precautions specified by the manufacturer. Avoid inhalation of any particulates that may be present in the pump.

CAUTION

Do not attempt to clean any parts of the pump other than external surfaces. Do not disassemble the pump or remove the electronics Podule. Use of solvents may damage internal pump components.

If the DX pump is contaminated inside, it may not be possible to achieve the specified ultimate vacuum or pump-down time may increase. The pump should be returned to an Edwards Service Centre where the pump will be dismantled and cleaned.

You can use any organic solvent to clean the external surfaces of your pump. We recommend that you use non-CFC solvents, such as isopropanol or ethanol. Use a cleaning solution that is suitable for the contaminants on the pump surfaces.

For environmental reasons, keep wastage of cleaning solutions and solvents to a minimum.

5.5 Fault finding

Refer to [Table 23](#) for the possible causes of faults and the recommended actions to rectify faults.

Table 23 - Fault finding

Symptom	Check	Action
The Podule LEDs do not flash for 0.5 seconds when system switched on	Has the electrical supply failed?	Ensure that the electrical supply is switched on and the fuses (and current limiting devices) have not been tripped.
The pump does not rotate after a parallel Start command is supplied	Check that the electricity supply is on and whether the Fail output is active	If there is a Fail signal, check whether the orange status LED is flashing. If it is, refer to Section 5.5.1 . If power is supplied, there is no Fail signal and the rotor still does not rotate then there is a fault with the pump.
The pump does not rotate after a serial Start command is sent	Check whether the pump returns a reply to your Start command	If there is no reply, check that the serial communications link is plugged in and that Serial Enable is active and that the electrical supply is on. Check whether the orange status LED is flashing. If it is, refer to 5.4.1.
The pump does not respond in multi-drop mode	Check that the multi-drop is enabled	Make sure the pump has a multi-drop address and that commands are sent using the multi-drop protocol.
The orange status LED flashes an error code	Note the position of the long flashes within the series of 6 flashes to work out the error code.	Look up the flashing error code in Section 5.5.1 and follow the advice given.
The green Normal LED does not go on or the pump is not rotating at full speed or the pump fails whilst running	Is the inlet pressure too high?	If so reduce the pumping load or check for a gross leak into the system.
	Is the pump running too hot?	Increase the cooling to your pump. You may need to change from air-cooling to water-cooling (refer to Section 2 for maximum inlet pressure and cooling requirements). You may need to increase cooling-water flow or decrease the water temperature or do both. Check that external heat sources (such as system bakeout heaters) are not excessive.
	Does the rotor rotate freely?	If not, the pump-bearings may be damaged. Contact your supplier or Edwards.

Table 23 - Fault finding (continued)

Symptom	Check	Action
Ultimate pressure cannot be reached	<p>Is the pressure limited by water vapour?</p> <p>Are any of the vacuum gauges contaminated?</p> <p>Is the pumping speed insufficient (due to poor conductance between the pump and the gauge or too large a chamber)?</p> <p>Is the interstage inlet pressure >0.5 mbar (50 Pa)</p> <p>Is the backing pressure >10 mbar (1×10^3 Pa)</p> <p>Is the high vacuum area of the system contaminated?</p> <p>Check the rest of your system for leaks and contamination.</p> <p>Remove the pump from the system and test the ultimate pressure of the pump alone (refer to Section 2)</p>	<p>Bake the system and pump.</p> <p>If so clean or replace them.</p> <p>Increase the conductance or reduce the volume.</p> <p>If the interstage inlet pressure is too high, inlet pressure at the turbomolecular inlet is increased; ensure that the interstage inlet pressure is <0.5 mbar (50 Pa).</p> <p>If so, the backing pressure may be too high. Check for backing pipeline leaks. If the throughput is high you may need a larger backing pump.</p> <p>If so, clean the high vacuum system.</p> <p>If found, repair the leaks and clean the contamination.</p> <p>If inlet pressure is poor, check the pump for contamination and refer to Section 5. Leak-test the pump. If the leak rate $>1 \times 10^{-7}$ mbar l s⁻¹ (1×10^{-5} Pa l s⁻¹) contact your supplier or Edwards.</p>
The pump is very noisy or there is excessive vibration or both	<p>Is the pump rotational speed the same as the resonant frequency of the attached system?</p> <p>Is the vibration being transmitted from the rotary backing pump?</p> <p>Is the noise irregular and getting progressively worse?</p> <p>Is the pump making a constant high pitched noise?</p>	<p>If so, change the natural frequency of your system or isolate the pump using flexible bellows.</p> <p>If so, fit flexible bellows or a vibration isolator in the backing line.</p> <p>If so, a bearing is defective. Contact your supplier or Edwards.</p> <p>If so, the rotor is out of balance. Contact your supplier or Edwards.</p>
Any other problems	-	Contact your supplier or Edwards.

5.5.1 Flashing error codes

Whenever a Fail condition becomes active the standard once-per-revolution flash on the Status LED is replaced with the Error Flash Codes that reflect all active error conditions. The Fail status flash code positions, within the Status LED error flash sequence, are specified in Table 24.

There is a sufficient off period between each subsequent cycle repetition to clearly mark the start of a new flash sequence. The duration of a long flash (L) is equal to 3 times the duration of a short flash (s).

Table 24 - Flashing error codes

Error flash position	Error flash code	Comments	Actions
0	ssssss	The speed fell below 50% of full rotational speed with the Timer disabled.	Check whether the pump is too hot or whether the inlet pressure is too high.
1	Lsssss	Podule internal software mismatch.	Cycle the power to the pump and see whether the error code appears again. If it does, contact your supplier or Edwards.
2	sLssss	Podule failed internal configuration and calibration operation.	Cycle the power to the pump and see whether the error code appears again. If it does, contact your supplier or Edwards.
3	ssLsss	Failure to reach or maintain half full speed within the timer setting value.	Check whether the pump is too hot or whether the inlet pressure is too high.
4	sssLss	Overspeed or Overcurrent trip activated.	Cycle the power to the pump and see whether the error code appears again. If it does, contact your supplier or Edwards.
5	ssssLs	Pump internal measurement system disconnected or damaged.	Cycle the power to the pump and see whether the error code appears again. If it does, contact your supplier or Edwards.
6	sssssL	Serial enable becomes inactive following a Serial Start command.	Re-activate Serial Enable and send a Serial Stop command to clear the error code.

Note: The status LED error flash sequence is capable of signalling multiple fail conditions. For example, error flash code sLssLs signifies both error 2 (Podule failed internal configuration and calibration operation) and error 5 (pump internal measurement system disconnected or damaged).

5.5.2 Decoding system status words

If you are using the serial communications link you will be able to access further information that may be useful for fault finding. When you send a query to monitor measured motor speed, the pump also returns a System Status Word.

The send command is as follows:

```
Command  ?  v  8  5  2  cr
```

You will receive the following reply, where the first returned number refers to motor rotational speed in revolutions per second (Hz):

```
Reply  =  v  8  5  2  sp  d  d  d  d  ;  h  h  h  h  h  h  h  h  cr
```

The System Status Word returned is made up of 8 hexadecimal digits. To decode this word, you must convert each digit into a 4-digit binary number. (Table 25 is provided as an aid.) Follow the example below:

2	2	8	3	0	0	2	2
↓	↓	↓	↓	↓	↓	↓	↓
0 0 1 0	0 0 1 0	1 0 0 0	0 0 1 1	0 0 0 0	0 0 0 0	0 0 1 0	0 0 1 0

Table 25 - Hexadecimal conversion table

Hexadecimal	Binary	Decimal
0	0000	0
1	0001	1
2	0010	2
3	0011	3
4	0100	4
5	0101	5
6	0110	6
7	0111	7
8	1000	8
9	1001	9
A	1010	10
B	1011	11
C	1100	12
D	1101	13
E	1110	14
F	1111	15

Each binary digit (bit) represents a flag that is either active (state 1) or not active (state 0). To help decode the System Status Word, each bit is numbered (starting with 0 for the least significant to 31 for the most significant) as shown below.

Table 26 contains a list of the lower 16 status flags that will be useful for fault finding. The upper 16 status flags are reserved by Edwards.

Binary digits

0	0	1	0	0	0	1	0	1	0	0	0	0	0	1	1	0	0	0	0	0	0	0	0	0	1	0	0	0	1	0					
↓	↓	↓	↓	↓	↓	↓	↓	↓	↓	↓	↓	↓	↓	↓	↓	↓	↓	↓	↓	↓	↓	↓	↓	↓	↓	↓	↓	↓	↓	↓					
3	3	2	2	2	2	2	2	2	2	2	2	2	1	1	1	1	1	1	1	1	1	1	1	1	0	9	8	7	6	5	4	3	2	1	0
1	0	9	8	7	6	5	4	3	2	1	0	9	8	7	6	5	4	3	2	1	0	9	8	7	6	5	4	3	2	1	0				

Bit numbers

Table 26 - Status flags

Bit number	Status flag	Active flags means
0	Fail	Fail status condition active
1	Stopped speed	Below stopped speed
2	Normal speed	Above normal speed

Table 26 - Status flags (continued)

Bit number	Status flag	Active flags means
3	Vent valve closed	Vent valve energised
4	Start	Start command active
5	Serial enable	Serial enable active
6	Standby	Standby active
7	Half full speed	Above 50% full rotational speed
8	Parallel control mode	Exclusive control mode selection
9	Serial control mode	Exclusive control mode selection
10	Invalid Podule software	Podule internal software mismatch
11	Podule upload incomplete	Podule failed internal configuration and calibration operation
12	Timer expired	Failure to reach or maintain half full speed within the timer setting value
13	Hardware trip	Overspeed or Overcurrent trip activated
14	Thermistor error	Pump internal temperature measurement system disconnected or damaged
15	Serial control mode interlock	Serial enable has become inactive following a serial Start command.

The System Status word used in the example above was obtained with the pump at rest. By decoding the word, we can learn more about the state of the pump. Refer to [Table 27](#).

Table 27 - Example decoding of system status words

Bit number	Status of bit (in example)	We can deduce
0	0	The pump has not failed
1	1	The pump is at rest
2	0	Speed is below normal speed
3	0	The vent valve is open
4	0	There is no active Start command
5	1	Serial enable is active
6	0	Standby is not active
7	0	Speed is below 50% of full rotational speed
8	0	The pump is not in parallel control mode
9	0	The pump is not serial control mode
10	0	There is no Podule internal software mismatch
11	0	Podule passed internal configuration and calibration operation
12	0	The timer has not timed out
13	0	Overspeed and Overcurrent trip not activated
14	0	Pump internal temperature measurement system is fine
15	0	Serial enable has not become inactive during serial control

5.5.3 Useful service information

If you are using the serial communications link, you can access information about your pump such as pump type and internal Podule software versions. This information is particularly useful for service personnel to determine what model of pump you have.

Send the following query to find out pump type:

<i>Command</i>	<i>?</i>	<i>s</i>	<i>8</i>	<i>5</i>	<i>1</i>	<i>cr</i>
----------------	----------	----------	----------	----------	----------	-----------

The reply you will receive is as follows, where String1 is the pump type, String2 is the DSP software version number and String3 is the designated full speed of the pump (in revolutions per second):

<i>Reply</i>	<i>=</i>	<i>s</i>	<i>8</i>	<i>5</i>	<i>1</i>	<i>sp</i>	<i>String 1</i>	<i>;</i>	<i>String 2</i>	<i>;</i>	<i>String 3</i>	<i>cr</i>
--------------	----------	----------	----------	----------	----------	-----------	-----------------	----------	-----------------	----------	-----------------	-----------

Send the following query to find out the PIC software version:

<i>Command</i>	<i>?</i>	<i>s</i>	<i>8</i>	<i>6</i>	<i>8</i>	<i>cr</i>
----------------	----------	----------	----------	----------	----------	-----------

The reply you will receive is as follows, where String1 is the PIC software version number:

<i>Reply</i>	<i>=</i>	<i>s</i>	<i>8</i>	<i>6</i>	<i>8</i>	<i>sp</i>	<i>String 1</i>	<i>cr</i>
--------------	----------	----------	----------	----------	----------	-----------	-----------------	-----------

This page has been intentionally left blank.

6 Storage and disposal

6.1 Storage

Use the following procedure to store the pump.

1. Place protective covers over the inlet, outlet, interstage (for the iDX only), purge and vent ports.
2. Place the pump in its packing materials. For fastest pump-down when the pump is put back into service, seal the pump inside a plastic bag together with a suitable desiccant.
3. Store the pump in cool, dry conditions until required for use. Refer to [Table 13](#) for recommended storage environment. When required, prepare and install the pump as described in [Section 3](#).
4. Keep the pump upright at all times to prevent the drainage of oil from the bearing reservoir.
5. Avoid long-term storage if possible. When long-term storage is necessary, the pump should be set up and run for at least eight hours every six months.

6.2 Disposal

WARNING



In the unlikely event of a failure of the pump rotor, dust can be generated from the carbon fibre reinforced components.

In this event, use appropriate personal protective equipment when handling and disposing of the pump and ensure that all pump inlets and outlets are capped off before disposal.

Dispose of the DX pump and any components and accessories safely in accordance with all local and national safety and environmental requirements.

Particular care must be taken with any components that have been contaminated with dangerous process substances.

Take appropriate action to avoid inhalation of any particles that may be present in the pump.

Do not incinerate the pump. The pump contains phenolic and fluorosilicone materials that can decompose to very dangerous substances when heated to high temperatures.

This page has been intentionally left blank.

7 Service, spares and accessories

7.1 Introduction

Edwards products, spares and accessories are available from Edwards companies in Belgium, Brazil, France, Germany, Hong Kong, Italy, Japan, Korea, United Kingdom, USA and a worldwide network of distributors. The majority of these employ service engineers who have undergone comprehensive Edwards training courses.

Order spare parts and accessories from your nearest Edwards company or distributor. When you order, please state for each part required:

- Model and Item Number of your equipment
- Serial number (if any)
- Item Number and description of the part

7.2 Service

Edwards products are supported by a worldwide network of Edwards Service Centres. Each Service Centre offers a wide range of options including: equipment decontamination; service exchange; repair; rebuild and testing to factory specifications. Equipment that has been serviced, repaired or rebuilt is returned with a full warranty.

Your local Service Centre can also provide Edwards engineers to support on-site maintenance, service or repair of your equipment.

For more information about service options, contact your nearest Service Centre or other Edwards company.

7.2.1 Returning a pump for service

If you need to send your pump to a Service Centre, use the returns procedure included at the end of this manual. The instruction in the returns procedure to drain all fluids does not apply to the lubricant in the pump oil-reservoirs. Do not return your pump with the accessories fitted. Remove all accessories and retain them for future use.

Ensure that a completed HS2 form is returned with the pump.

If you have configured your pump to suit your application, make sure you make a record of the configuration before returning your pump. All replacement pumps will be supplied with default factory settings. The TIC/DX PC Monitor program (available as an accessory) allows you to automatically download and save your configuration.

7.3 Spares

7.3.1 ISX inlet-screen

An inlet-screen is fitted to your pump as supplied to prevent damage from the entry of debris into the pump. The Item Numbers of replacement inlet-screens are given below. Select the inlet-screen according to the pump inlet-flange size. You cannot replace the inlet-screen on a pump with an NW inlet-flange.

Flange Size	Inlet Screen	Item Number
DN63ISO-K/ DN63CF	ISX 75D/63	B722-40-860
DN100ISO-K/ DN100CF	ISX100	B580-51-001

7.3.2 Inlet-strainer

The EXT75iDX and EXT255iDX pumps are supplied with an inlet-strainer for the interstage-port. The Item Number for a replacement inlet-strainer is given below.

Flange Size	Inlet Screen
DN25ISO-K	A223-05-067

7.3.3 Inlet-flange seals

DX pumps are supplied with an inlet-seal. The Item Numbers of replacement seals are given in [Table 28](#).

Table 28 - Inlet-flange seals

Flange size	Inlet-flange seal	Item number
DN63ISO-K	ISO63 trapped O-ring (fluoroelastomer)	B271-58-170
DN40NW	DN40NW Co-seal (fluoroelastomer)	B271-58-453
DN100ISO-K	ISO100 trapped O-ring (fluoroelastomer)	B271-58-171
DN63CF	63CF copper compression gasket (pack of 5)	C081-00-003
DN100CF	100CF copper compression gasket (pack of 5)	C082-00-003

7.4 Accessories

7.4.1 Installation

The accessories available for use with the DX pumps are described in the following section. [Figure 12](#) shows how the accessories are fitted to the pump.

7.4.2 ACX air-cooler

An ACX air-cooler can be fitted to the DX pump, refer to [Section 3.9](#) to check the suitability of air-cooling in a particular application.

Air-Cooler	Item Number	For use with
ACX75	B580-53-075	EXT75DX
ACX250H	B580-53-160	EXT255DX

7.4.3 WCX water-cooler

A water-cooler can be fitted to the DX pump refer to [Section 2.5](#) to check the suitability of the cooling-water supply.

Water-Cooler	Item Number
WCX500 water cooling kit	B736-00-121

7.4.4 BX bakeout band

A BX bakeout band accelerates the degassing of the pump to enable it to achieve lower pressures. It may also be used to protect the pump from condensation of contaminants. The bakeout bands are available in 110 - 120 V or 220 - 240 V versions.

Note: *The bakeout band is only for use with CF variants*

Bakeout Band	Item Number	For use with
BX70 (110 V, 30 W)	B580-52-040	EXT75DX
BX70 (240 V, 30 W)	B580-52-060	EXT75DX
BX250 (110 V, 30 W)	B580-52-041	EXT255DX
BX250 (240 V, 30 W)	B580-52-061	EXT255DX

7.4.5 TAV vent-valve and vent-port adaptor

Two solenoid-operated vent-valves are available for system venting. The valves are 24 V d.c., normally-open and can be driven by the Podule. The solenoid-valve is fitted in place of the manual-valve, or alternatively can be fitted with an adaptor (supplied with the valve) and can be used with any suitable NW10 flanged port on your vacuum system.

TAV5 is suitable for smaller vacuum systems. TAV6 has a higher conductance and is suitable for larger vacuum systems (typically with volume greater than 10 litres).

Product	Orifice Diameter	Item Number
TAV5 vent-valve	0.5 mm	B580-66-010
TAV6 vent-valve	1.0 mm	B580-66-020

7.4.6 VRX vent-restrictor

Use a VRX fixed orifice vent-restrictor to restrict flow of vent gas into the pump. You can fit a VRX vent-restrictor to the inlet of a TAV5 or TAV6 vent-valve or to a PRX10 purge-restrictor. Refer to [Table 19](#) for information on the selection of the correct VRX vent-restrictor and to [Table 29](#) for the item numbers of the vent-restrictors available.

Table 29 - Vent restrictors

Vent-restrictor	Orifice diameter (mm)	Item number
VRX10	0.1	B580-66-021
VRX20	0.2	B580-66-022
VRX30	0.3	B580-66-023
VRX50	0.5	B580-66-024
VRX70	0.7	B580-66-025

7.4.7 Vent-port adaptor

The vent-port adaptor has a 1/8 inch BSP male thread that can be screwed into both the vent-port and purge-port, making them suitable for NW10 fittings.

Vent-port adaptor	Item Number
Vent-Port adaptor NW10 -1/8 inch BSP male	B580-66-011

7.4.8 PRX purge-restrictor

The PRX10 is a modified DN10NW centring-ring that filters the purge gas and restricts its flow rate to the recommended flow of 25 sccm. You must fit a vent-port adaptor to the purge-port in order to connect a purge-restrictor to the pump.

Purge restrictor	Flange size	Item Number
PRX10	NW10	B580-65-001

7.4.9 Vibration isolators

In applications where the small amount of vibration generated by the compound turbomolecular pump is a problem, a vibration isolator can be fitted. The isolator consists of two special flanges separated by a flexible bellows and a rubber, anti-vibration, outer collar. The vibration isolator required depends on the pump inlet-flange size.

Note: The vibration isolator is designed for use with vertically mounted pumps only.

Flange Size	Item Number
DN63ISO-K	B581-15-000
DN63CF	B581-01-000
DN100ISO-K	B581-20-000
DN100CF	B581-05-000

7.4.10 FL20K foreline trap

The foreline trap minimises oil vapour backstreaming from the backing pump and is recommended where the highest system cleanliness is required.

Foreline trap	Item Number
FL20K	A133-05-000

7.4.11 Podule connector plug

A Podule connector plug can be fitted to the DX pump to drive a TAV vent valve or an ACX air cooler.

Product	Item Number
Podule connector plug	B722-40-808

7.4.12 TIC turbo and instrument controllers

There are three different types of controller available. The first is an Instrument Controller (IC), used to control gauges only and is not suitable to power an EXT turbo pump or backing pump. The second is a Turbo Controller (TC), used to control just a 24 V EXT turbo pump and a backing pump. The last is a Turbo Instrument Controller (TIC), used to control a 24V EXT turbo pump, backing pump and up to 3 gauges.

Controller Type	Item Number
TIC Turbo Controller (100 W)	D397-11-000
TIC Turbo Controller (200 W)	D397-12-000
TIC Turbo and Instrument Controller (100 W)	D397-21-000
TIC Turbo and Instrument Controller (200 W)	D397-22-000

7.4.13 TIC PC Program

The TIC PC Program is a piece of PC-based software that is supplied with the TIC and can be used for retrieving and setting the user-configurable parameters in the pump.

Figure 12 - Installation of optional accessories and spares

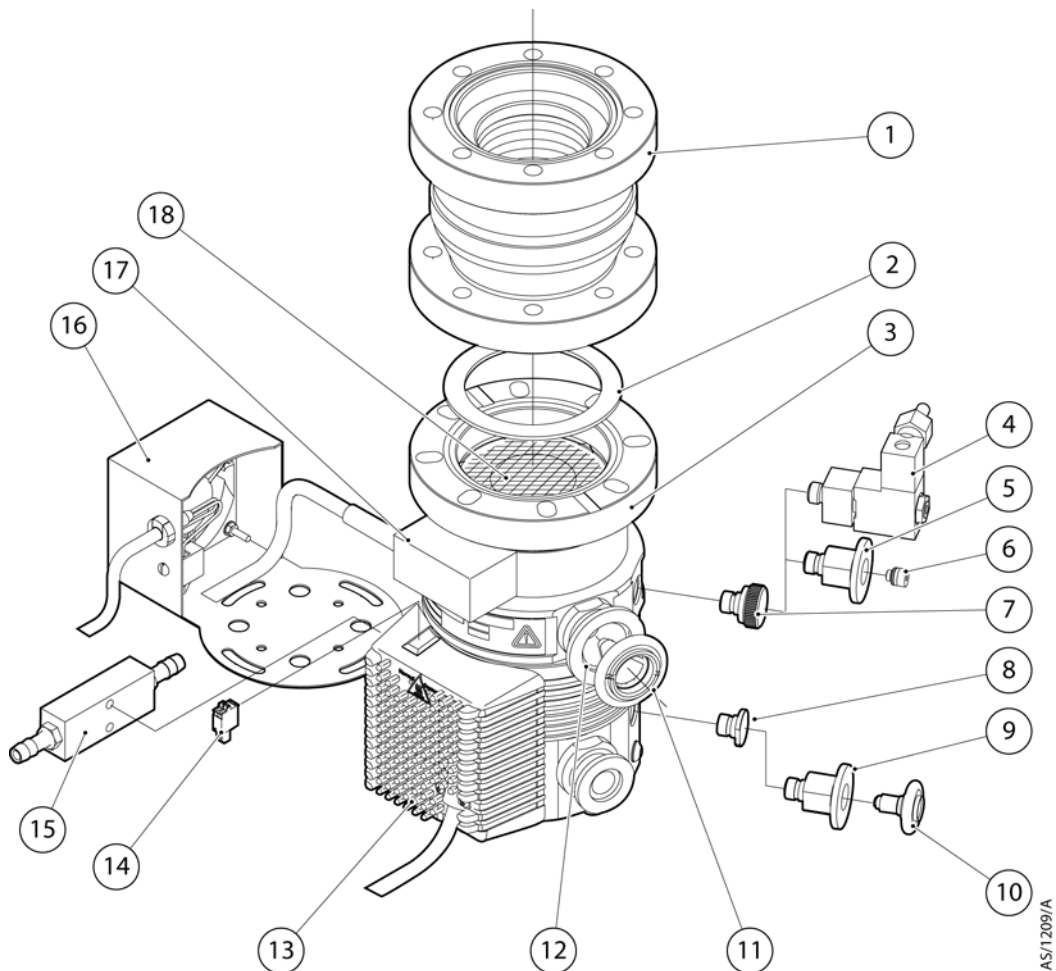

- | | |
|---------------------------------|--|
| 1. Vibration isolator | 10. PRX purge restrictor |
| 2. Inlet-flange seal (supplied) | 11. Inlet-strainer (supplied) ¹ |
| 3. DX pump | 12. Interstage port ¹ |
| 4. TAV vent valve | 13. Podule |
| 5. Vent port adaptor | 14. Podule connector socket (for fan/TAV valve) (supplied) |
| 6. VRX vent-restrictor | 15. WCX water-cooler |
| 7. Manual vent valve (supplied) | 16. ACX air cooler |
| 8. Purge port blank (supplied) | 17. BX bakeout band |
| 9. Purge port adaptor | 18. Inlet-screen (supplied fitted) |

¹ EXT75iDX and EXT255iDX only

AS/1209/A

This page has been intentionally left blank.

Index

A

Accessories	64
ACX air-cooler	64
Alternative valve connected to the vacuum system	35
Analogue output	4
Analogue signal options	43
Assigning a multi-drop address	44
Automatic vent options	4

B

Backing connection	23
Bakeout	51
Base mounting	22
Bearing maintenance	53
BX bakeout band	65

C

Clean the external surfaces of the pump	53
Close the vent valve	45
Command set	30
Configuring the DX pump using a TIC	45
Connect the electrical supply	25
Connect the logic interface to the TIC	24
Connect the logic interface to your control equipment	24
Connect the purge gas	24
Connect the serial interface to your control equipment	27
Connection to the vacuum system	19
Controlled venting	35
Controlled venting options	40
Cooling water	14

D

Decelerating and venting	49
Decoding system status words	56
Delayed start	47
Disposal	61
Drive electronics	2

E

Earth (ground) connections	24
Electrical data	15
Electrical installation	24
Electrical supply failure	50
Electronic braking	5
Electronic braking options	43

F

Factory settings	44
Fault finding	54
FL20K foreline trap	66
Flashing error codes	56
Forced air cooling	36
Full serial control	6

G

General description	1
---------------------------	---

I

Indicator LEDs	18
Inlet-connection and orientation	22
Inlet-flange seals	64
Inlet-screen (supplied fitted)	21
Inlet-strainer	64
Installation	19, 64
Interstage connection (iDX variants only)	23
ISX inlet-screen	63

L

Link parameter readings	48
Logic interface	5
Logic interface connector	15

M

Maintenance	53
Manual vent valve	34
Materials exposed to gases pumped	14
Measured motor speed	48
Mechanical fixing	22
Message protocol	29
Multi-drop mode	33

N

Normal speed setting	4, 41
----------------------------	-------

O

Operating and storage environment	18
Operation	39
Operation at extreme conditions	49
Operation at high temperatures	50
Operation at over-speed	50
Operation with high inlet pressure	49
Operation with parallel control and monitoring	46
Operation with serial control and monitoring	47
Operational features	3

P

Parallel control and monitoring	5
Parallel control with occasional serial monitoring or serial set-up	6
Parallel interface mode	26
Parallel monitoring	47
Podule configuration (serial set-up)	6
Podule connector plug	66
Podule connector socket	16
Power limit setting	3, 39
Powering a fan from the podule	40
Pre-start checks	46
PRX purge-restrictor	66
Pumping media	7
Purge gas connection	24
Purge gas specification	14

R

Recommended purge gas flow	24
Returning a pump for service	63
Rotor life	53
Running at standby speed	46

S

Scope and definitions	1
Serial control with parallel monitoring	6
Serial enable	28
Serial interface mode	27
Serial protocol	28
Service	63
Shutdown	63
Simultaneous parallel and serial operation	30, 49
Spares	63
Standby speed	3, 47
Standby speed setting	41
Start the pump	46, 47
Start-up	45
Stop the pump	46, 48
Storage	61
Storage and disposal	61

T

TAV vent-valve and vent-port adaptor	65
TAV5 or TAV6 solenoid vent valve	34
Technical data	7
Temperature readings	48
Timer	3
Timer setting and options	42
Typical installation	19

U

Unpack and inspect	19
Useful service information	59

V

Vent gas specification and vent control data	13
Vent options, vent valve connection and control ..	34
Vent-port adaptor	65
Vibration isolators	66
VRX vent-restrictor	65

W

Water-cooling	36
WCX water-cooler	64