



Leak Detection

The Varian Advantage	224-225
Advantages of Helium Leak Detection	226-227
Leak Detection Methods	228-229
Typical Applications	230-233
Varian Leak Detection Instruments	234-250
Accessories and Options	251-255
Training	256-257
Worldwide Service and Support	258
Reference Library	259
Design and Application Considerations	260-261
Technical Notes	262-263

The Varian Advantage

Increasingly rigorous standards in today's manufacturing and research and development environments require complete leak detection solutions. We are committed to helping you **Maximize your Productivity and Uptime**. We provide global applications support to help you define the best solution, high performance instruments that are powerful, intelligent and easy to use, and industry leading service and support to get you up and running, and keep you there.



Global Applications Support

Expertise When & Where You Need It.

- Toll-free hotlines provide easy accessibility to live, front-end support
- Worldwide customer service representatives to assist you with order status, pricing and delivery, and service information
- Native language applications specialists available locally, worldwide
- Application specific consulting
- More than ten thousand installed systems delivering application solutions to customers in a broad range of industries



High Performance Instruments

From simple, push button operation to fully automated state-of-the-art instruments



- Easy to Use
- Powerful
- Versatile
- Dependable



Industry Leading Service & Support

Get The Most From Your Investment.

- Most extensive network of service engineers available locally to meet your needs
- Varian's flexible and comprehensive service plans provide the service and support necessary for years of trouble free operation.
- Services include applications assistance, start-up support, vacuum and leak detection training, comprehensive maintenance, service agreements, and warranty extensions
- Technical support engineers offer quick, competent responses to your needs for technical product data, troubleshooting, and literature.





Application Notes and Literature

Our offering of technical information will help guide you to the most appropriate leak detection method or system design for your specific application.

- Application notes available at no cost to you
- Varian handbooks on leak detection principles, operation, and techniques
- See our Reference Library on page 259



Training

Varian's training programs are staffed by dedicated professionals with expertise and experience in a broad range of vacuum and leak detection technologies.

- Several courses covering leak detection applications, techniques, and maintenance are available
- Limited enrollment ensures access to instructors and hands-on activities
- Classes are taught at Varian facilities on a regularly scheduled basis
- Courses can be customized for group training at your facility
- More details available on page 256, or see Training Section of the Varian catalog, or visit us at varianinc.com



Vacuum Technologies Catalog on CD

CD compilation of the complete catalog of vacuum products and services from Varian, plus a user-friendly interactive catalog of our extensive offering of primary, high, and ultra-high vacuum pumps, rich with information on applications, methods, and recommended equipment.



Complete Line of Vacuum Pumps

Varian is a Total Vacuum Solutions provider, offering a comprehensive choice of vacuum pumps.

- Rotary Vane and Dry Scroll primary pumps
- Turbo/drag high vacuum pumps
- Specifically designed for Leak Detection applications
- See page 250 and dedicated sections of the Varian catalog for more information

Leak Detectors

Advantages of Helium Leak Detection

Why Helium Leak Detection?

Helium is a superior choice of tracer gas used to find leaks for a multitude of reasons. Helium is:

- Non-toxic
- Inert and non-condensable
- Normally not present in the atmosphere at more than trace amounts
- Relatively inexpensive
- Readily passes through leaks due to its small atomic size
- Non-flammable
- Available in various size cylinders
- Available in purities appropriate for medical usage

The only molecule smaller than helium (mass 4) is hydrogen (mass 2), which is not inert. Helium is much lighter than the next heavier inert molecule, neon (mass 20) which is much more expensive. Helium is present at a concentration of only 5 ppm in normal atmospheric conditions.

Other Leak Test Methods Often Fall Short

There are many other methods of leak testing but none that can match the ability of helium leak testing to locate and quantify leaks (Figure 1).

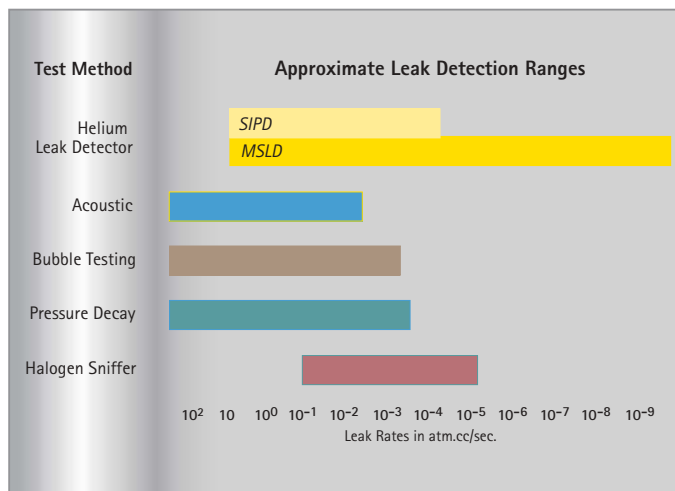

Figure 1 - Leak Test Methods Comparison

Acoustic Leak Detection uses sonic or ultrasonic energy that is generated by a gas as it expands through an orifice. This method is fairly simple and fast but is only sensitive to 10⁻³ atm cc/second.

Bubble Testing is a common method of leak detection in industry today. It can be as simple as pressurizing a part, placing it under water, and looking for leaks. It can also be done by pressurizing the part with air, applying a soapy solution, and looking for bubbles. This method is simple and cost effective for locating large leaks but also has its drawbacks. The test piece gets wet and may therefore need drying. It also cannot measure total leakage rates and is only useful for 10⁻⁴ atm cc/second leaks and larger.

Pressure Decay is commonly used in plumbing and many other industries. It may only involve a compressor and a pressure gauge, though some systems can be much more complex and expensive. The sensitivity of this method is proportional to time but generally limited to 10⁻⁴ atm cc/second. Another problem with this method is that fluctuations in temperature degrade the accuracy of the tests.

Halogen Gas Detection is commonly used in the air conditioning and cooling industry. This technology uses an infrared type detector to detect the presence of halogen tracer gas. This requires the test piece to be charged with Halogen, which is impractical, expensive, and can be an environmental issue.

Varian's Helium Leak Detection Technologies

A Mass Spectrometer Leak Detector (**MSLD**) is a complete system for locating and/or measuring the size of leaks into or out of a device or a container. This method of leak detection is initiated when a tracer gas, helium, is introduced to a test part that is connected to the MSLD system. The helium leaking from the test part diffuses through the system, its partial pressure is measured, and results are displayed.

The MSLD operating principle consists of ionization of the gases in a vacuum and their acceleration across a voltage drop and a magnetic field (Figure 2). The helium ions are separated and collected, and the resulting ion current is amplified and indicated on the display.

A mass spectrometer leak detector consists of the following components:

- A spectrometer tuned to detect helium
- A vacuum system to maintain adequately low pressure in the spectrometer
- Primary pumps to evacuate the part to be tested
- Valves that enable the various stages of the leak detection cycle, from evacuation, to test, to venting
- Amplifier and readout instrumentation that monitors spectrometer output signal
- Electrical power supplies and controls that sequence valve's, protective circuits, etc.
- Fixturing that attaches the part to be leak-tested to the leak testing equipment

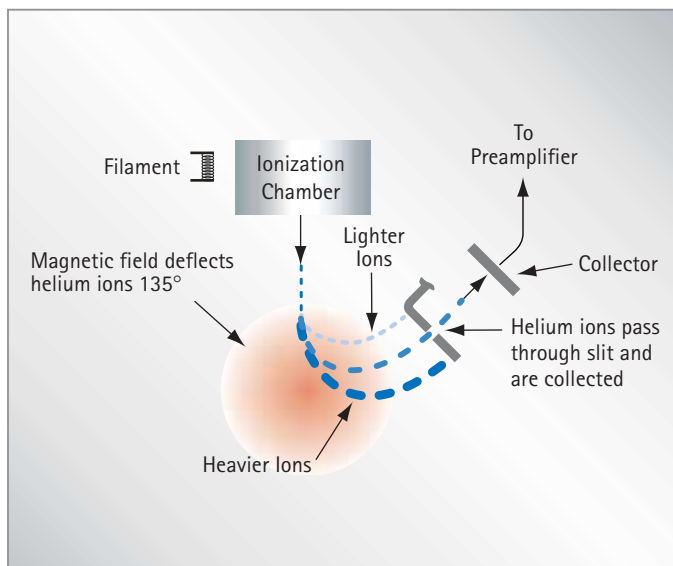

Figure 2 - Mass Spectrometer Tube Schematic

The PHD-4 Portable Helium Detector is also sensitive to helium and is based on a patented technology called Selective Ion Pump Detection (**SIPD**) (Figure 3). The sensor technology incorporates an ion pump connected to a quartz capillary tube and maintained under high vacuum. This membrane is heated with a coiled platinum filament. Once heated, the membrane becomes permeable to helium. As the partial pressure of helium in the ion pump increases, so does the current draw of the ion pump. This current is proportional to the pressure and is therefore representative of the helium at the test probe of the PHD-4.

A selective ion pump detector consists of the following:

- an ion pump and controller
- A permeable quartz capillary
- A heater coil that surrounds the quartz capillary
- Electronics to process the signal
- Display for access to leak rate and other unit functions

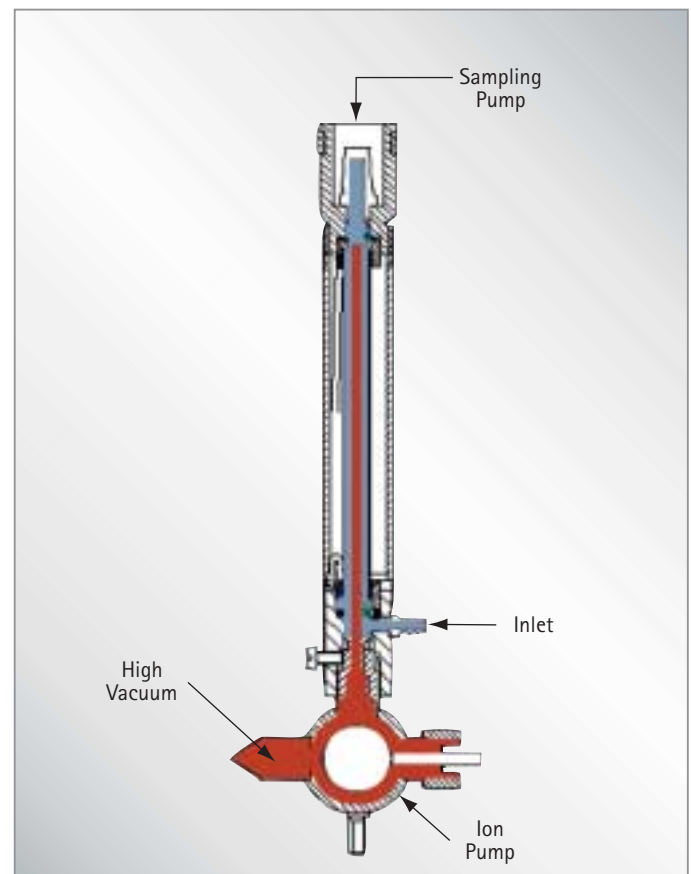

Figure 3 - Selective Ion Pump Detector

Leak Detection Methods

Methods of Leak Testing

There are many different ways to leak test parts using helium as a tracer gas. In general, the leak detection method is selected based on the actual working conditions of the part being tested. It is recommended that during leak testing, the same pressure differential be maintained and in the same "direction" as exists during the actual use of the part. For example, a vacuum system is tested with a vacuum inside the chamber, while a compressed air cylinder should be tested with a high pressure inside the cylinder.

There are also two general concerns when leak testing. One is the location of leaks and the other is the measurement of the total leakage rate of the part, as some leakage may be acceptable. In many cases, parts may be first tested to determine if they pass an acceptable level, and if not, the part may be taken off line and subjected to a second test with the intent of locating the leak. Additionally, many parts may be tested in batches. If a batch fails, the individual parts in that batch may then be tested separately to identify the leaking part(s).

Vacuum Testing Method (Outside-in)

The part to be tested is evacuated with a separate pumping system for large volumes, or with just the leak detector itself. When the appropriate cross over pressure has been reached, the leak detector is valved-in or transfers into test and the part is tested using one of the following methods:

Locating Leaks (Figure 1)

To pinpoint the location of the leak(s) (but not measure the total leakage rate), helium is administered to the suspected leak sites of the part using a spray probe with an adjustable flow.

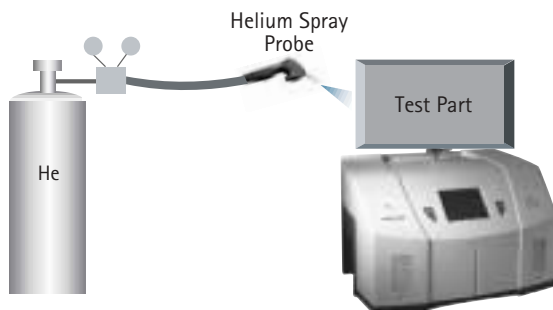

Figure 1 Locating Leaks – Outside-in

Measuring Leaks (Figure 2)

To determine the total quantity of leakage (but not the number or location of leaks), the part is connected to the leak detector and shrouded by a helium environment. This helium environment can be contained in many methods ranging from a simple plastic bag to more complex bell jar arrangements.

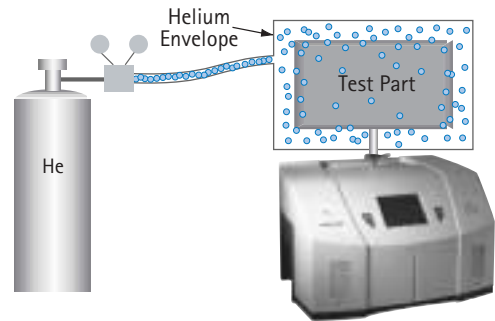

Figure 2 Measuring Leaks – Outside-In

Pressure Testing Method (Inside-out)

In this technique, the part is pressurized with helium or a mixture of helium and air, and tested by one of the following methods:

Measuring Leaks (Figure 3)

To determine the total quantity of leakage (but not the number or location of leaks), the part is pressurized with helium (or a mixture of helium and air or nitrogen). This can be done by bombing or backfilling small hermetically sealed parts. Larger parts can be actively pressurized using a hose or tubing to deliver the helium. The part is placed in a volume that is then evacuated by the leak detector. All the helium escaping from the part is captured and quantified.

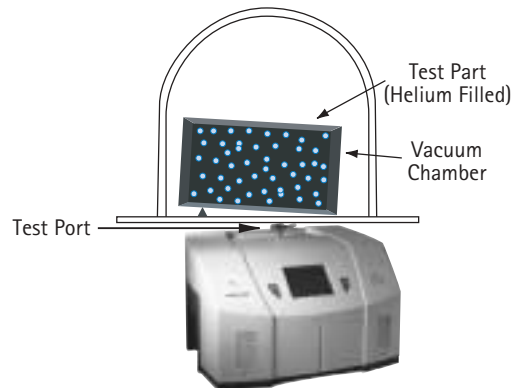

Figure 3 Measuring Leaks Inside-out

Locating Leaks (Figure 4)

To pinpoint the location of the leak(s) (but not measure the total leakage), the likely potential leak sites of the part are scanned using a Sniffer Probe connected to the inlet of the leak detector.

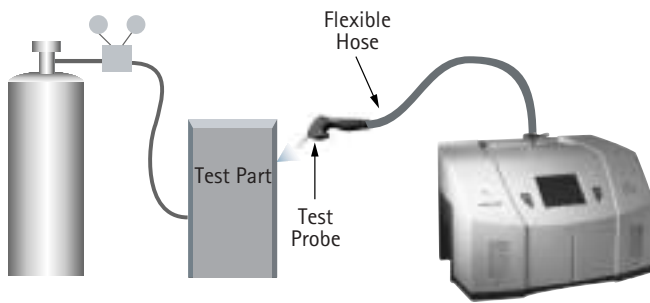

Figure 4 Locating Leaks – Inside Out

Accumulation Testing Method (Figure 5)

This method can both locate and quantify leaks. Some type of shroud or hood is placed in such a manner as to envelop a potential leak site. A certain amount of time is given to allow leaking helium to accumulate in the shrouded area, increasing the helium concentration. The leak detector is then valved-in to the shrouded volume. If many potential leak sites exist in a manifold or if many parts are to be tested at the same time, they can be sequentially valved-in to determine which site is leaking.

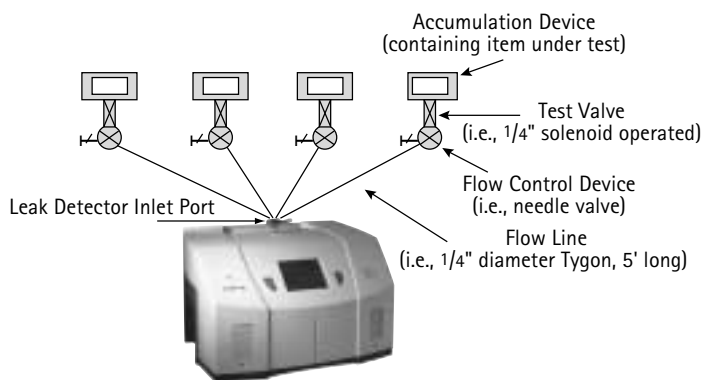

Figure 5 Accumulation – Inside-out

System Leak Test Methods

Systems, like individual parts, should be tested with the same pressure differential and in the same direction as in actual use. Therefore, systems that are under vacuum while in operation should be leak tested under vacuum, while pressurized systems should be charged with helium to a pressure similar to operational conditions when possible.

Vacuum Systems (Figure 6)

In general, vacuum systems are tested with a portable leak detector. Typically the leak detector is connected by means of a "tee" connected in between the foreline of the high vacuum pump and the inlet of its backing pump. A system should be capable of maintaining a foreline pressure low enough to operate the leak detector at this location. Helium is supplied to potential leak site using a spray probe or "bagging" suspected areas. If a leak exists, helium will enter the system and rapidly diffuse through it. The leak detector should respond within several seconds or less. Note that leak detector sensitivity will be diminished in systems with large backing pumps. If a system is using a cryopump as a high vacuum pump, it must be valved off before helium is introduced as cryopumps have limited helium pumping capacity.

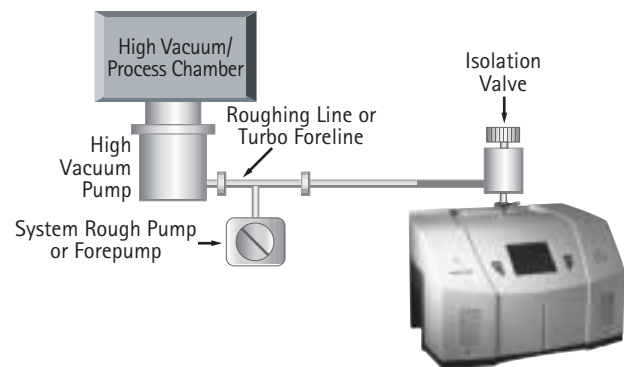

Figure 6 Vacuum System

Pressurized systems

Many different types of pressurized systems also need to be leak-free. These systems can be charged with helium or some mixture of helium and another gas such as nitrogen. If a diluted helium mixture is used, the helium signal will be diminished proportionally. For example, if a mixture of 10% helium and 90% nitrogen is used, the signal will read 10% of the actual value of the leak, or a decade lower. This may be acceptable in many cases as system leak checking is usually to locate rather than quantify leaks. Once the system has been charged with an appropriate amount of helium, leak checking can be performed by means of a sniffer probe, or by "bagging" suspected leak sites so that leaking helium will accumulate to a detectable level.

Typical Leak Detection Applications



Quality Control of Production Parts and Assemblies

The detection and location of leaks is critical in the production of many products from individual components, to sub-assemblies, to completed systems. In many of these cases, it is as important to know the size or rate of the leak as it is the location. Whether quantitative or qualitative testing is required, our leak detectors help assure the leak integrity of your parts or assemblies. Some examples include:

Evacuated parts and assemblies

- Hermetically sealed electronic packages
- Valves and manifolding
- Feedthroughs/glass-to-metal seals
- Vacuum vessels and systems

Pressurized parts and assemblies

- Air conditioning and refrigeration assemblies
- Radiators, heat exchangers, and condensers
- Brake, fuel, and hydraulic lines
- Gas tanks
- Food storage tanks and packaging
- Body implantable medical devices
- High purity piping

Maintenance of Systems

Many vacuum process tools in fabs of all types require occasional leak checking. This may be part of a preventative maintenance schedule or in the event of an unexpected failure. Downtime in either case must be minimized. A rugged, dependable, fast starting leak detector is essential to maximize up time of production tools. Varian VS Series, 959, and PHD-4 portable leak detectors keep industry moving. Examples of some of these applications are:

Vacuum process equipment or tools

- Vacuum furnaces
- Vacuum coaters
- Beam lines
- Electron beam and ion beam process equipment
- Analytical Instruments
- Semiconductor process tools
- Laser process equipment

Pressurized systems

- Power Plants
- Underground tanks, cables, and pipes
- High purity gas handling systems
- Bioreactors and fermenters
- Liquid gas manufacturing facilities
- Fuel tanks and bladders

System Integrated Leak Detection

Manufacturers of large, complex systems may choose to integrate into those systems a component leak detector that can facilitate the on-going maintenance of leak-free integrity, thereby providing additional value to their customers. The Varian 990CLD and 990dCLDII provide the necessary elements for flexible integration of leak detection capability into a large system. Examples of these systems are:

- Semiconductor process equipment
- PVD/CVD equipment
- E-beam and ion beam processing equipment



Courtesy of Cincinnati Test Systems



Mass Produced Parts

Some manufacturing processes require the integration of a leak checking device into a multi-step process, usually with very high production rates. Component leak detectors are designed specifically for these applications in which a vacuum system and the control electronics may be mounted separately. The Varian 990CLD and 990dCLDII offer the ultimate flexibility in a helium mass spectrometer leak detection system. The flexibility, ruggedness and rapid response time of these units allows for accurate, repeatable, high volume leak testing in demanding production environments. Some examples include:

High Volume Manufactured Parts

- Automotive fuel systems
- Automotive brake components
- Cooling and refrigeration system components
- Medical devices
- Automotive airbag components
- Tire and wheel assemblies

Portable Sniffing Applications

Some applications require operators or technicians to look for leaks from a ladder, outdoors, above or below ground, or in a densely constructed industrial facility or power plant. In these cases, a mobile cart-mounted MSLD may not be practical. A truly portable unit such as the PHD-4 is required. Some examples of such applications are:

- Aircraft manufacturing and maintenance
- Power generating plants
- Pressurized pipelines
- Bioreactors and fermenters
- Petrochemical plants and refineries
- Underground tanks
- Large condensers or heat exchangers

Applications Table

General Guidelines for Leak Detection Methods and Equipment

The chart below is a general guide to assist you in determining which leak detector and test method is the correct solution for your application. This information should be used in conjunction with guidance from your Varian Sales Engineer.

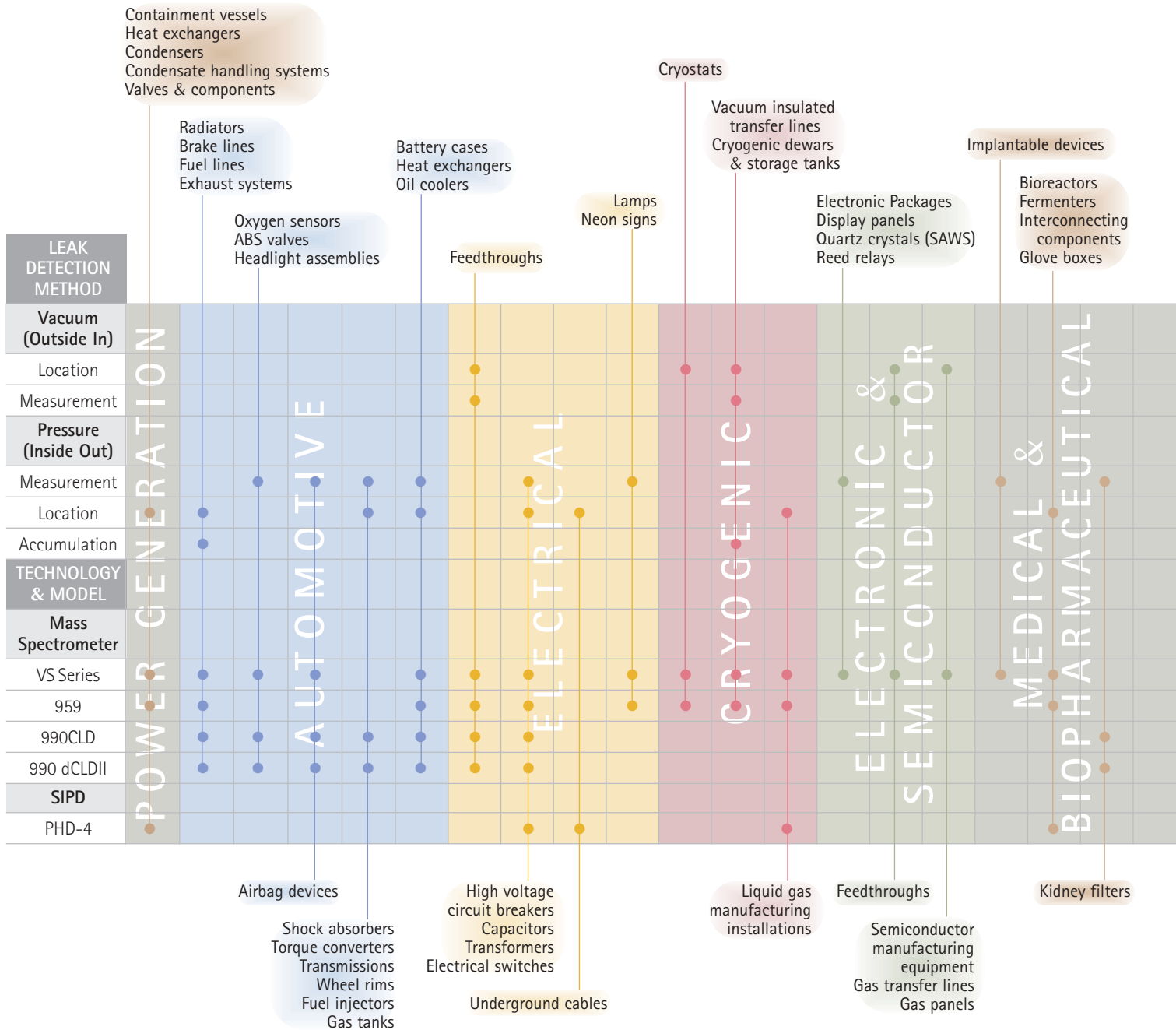

To determine the appropriate leak detector for your application:

1. Find the colored column of table that relates to your application: Power Generation, Automotive, etc.
2. Find part(s) that are similar to your part to be tested. The parts are shown on the top and bottom of the table.
3. Find dots that indicate the suggested leak check method and equipment.

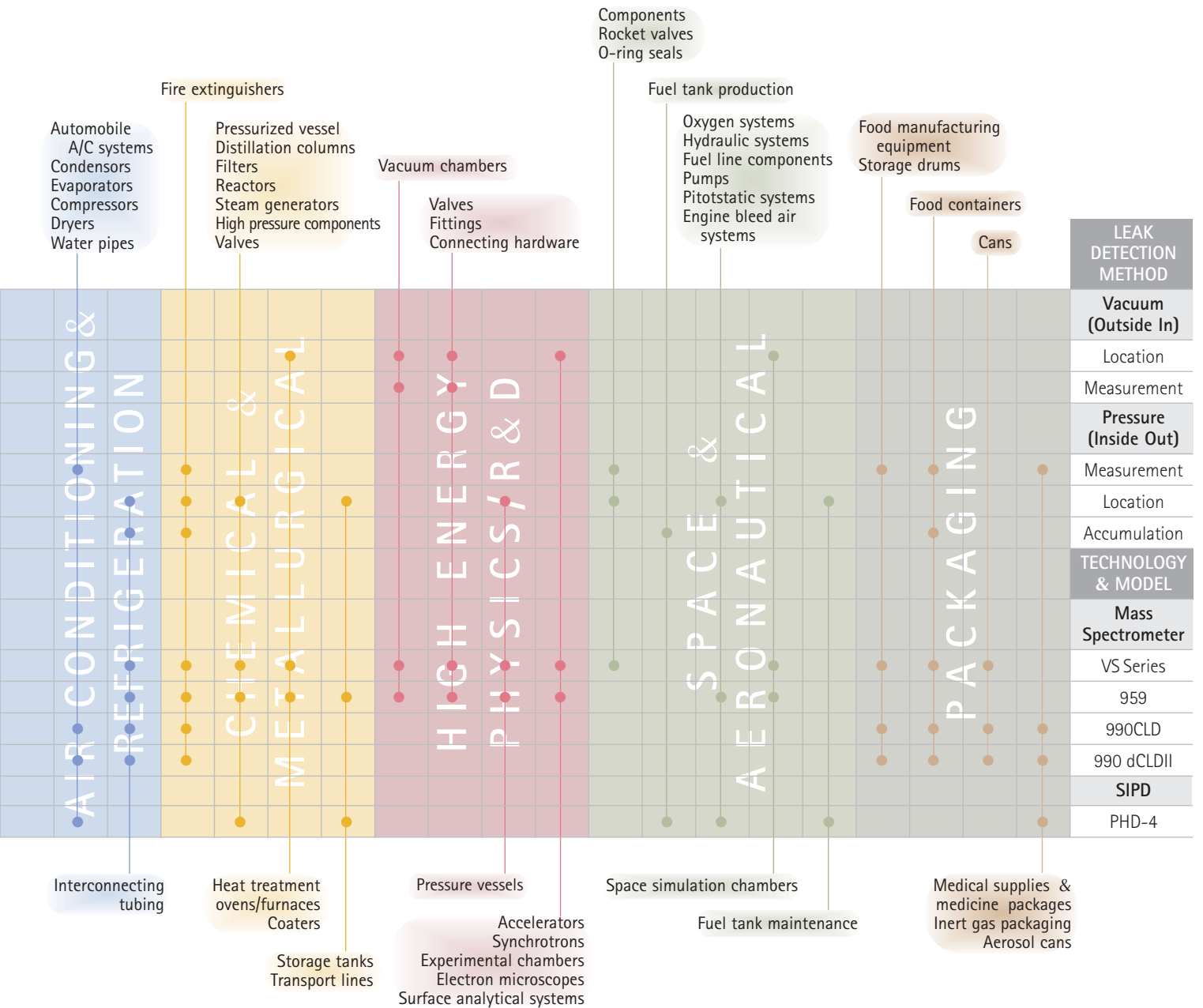

Leak Detectors

Varian Leak Detection Instruments

Mass Spectrometer

		Portable	Bench Mount	Mobile
		VS PR02	VS BR15 & MR15	VS BD30 & MD30
Primary Pumps		DS 42 RVP (Internal)	DS 302	TriScroll 620
Nominal Pumping Speed	m ³ /hr (l/min)	2 (34)	14 (232)	30 (500)
Sensitivity Ranges	atm cc/sec	5 x 10 ⁻¹²	5 x 10 ⁻¹²	5 x 10 ⁻¹²
Minimum Detectable Leak		5 x 10 ⁻¹² atm cc/sec; 5 x 10 ⁻¹² mbar l/s; 5 x 10 ⁻¹³ Pa m ³ /sec		
Maximum Test Port Pressure		13 mbar; 10 Torr; 1330 Pa		
Calibration		Automated or Manual (Internal or External)		
Background Suppression		Push Button Initiated Auto Zero, and Auto Zero < Zero Function		
Communication Interface		RS-232 Isolated Interface @ 9600 baud (DB-9S)		
Auto Sequencer		-		
Set Points		5 Set Points Standard, N/O or N/C; 3 Leak Rate, 1 Pressure, 1 Audio		
Remote Display/Control		-		
Weight (base unit)	kg (lbs)	38 (83)	BR15: 51 (112) MR15: 81 (178)	BD30: 62 (137) MD30: 92 (202)
Compliance to Norms		CE, UL/CSA		



VS Series



959

Leak Detectors (MSLD)

Selective Ion Pump Detector

Mobile	Component		Portable Sniffer
959	990dCLDII	990CLD	PHD-4
Dry Scroll or Rotary Vane	Dry Scroll or Rotary Vane		-
Options as required	Options as required		-
1×10^{-4} through 1×10^{-8}	V70D: 1×10^{-4} through 1×10^{-8} V70LP: 1×10^{-3} through 1×10^{-7}		-
2×10^{-9} atm cc/sec	V70D: 2×10^{-9} atm cc/sec V70LP: 2×10^{-8} atm cc/sec		5×10^{-6} atm cc/sec 5×10^{-6} mbar l/s 5×10^{-7} Pa m ³ /sec
1 Torr	V70D: 3 Torr V70LP: 5 Torr		-
Manual	Automatic/Manual	Manual	-
Manual	Automatic/Manual Auto Zero < Zero	Manual	Automatic/Manual
-	RS-232, Discrete I/O	Discrete I/O	Standard Analog and RS-232 Serial Output
-	-	Standard	-
-	Four (4)	Four (4)	-
-	Optional	-	-
23 (50)	Control Unit: 12 (27) Turbo/Spec Tube: 8 (17)	Control Unit: 11 (24) Turbo/Spec Tube: 7 (15)	2.6 (5.7)
-	-	-	CE, CSA/US



990CLD



PHD-4



990dCLDII

Leak Detectors

VS Series

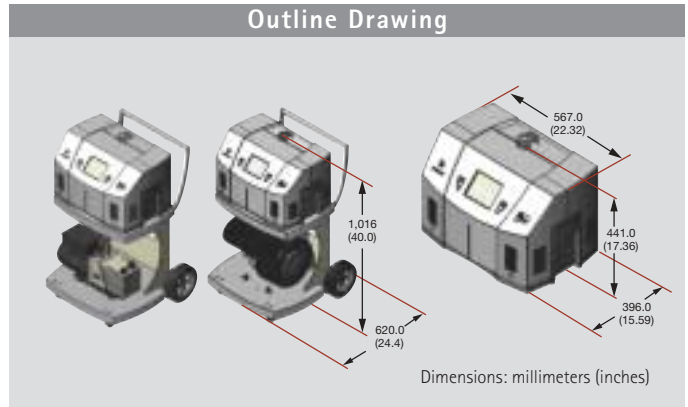

Technical Specifications

Model Number	PR02	MR15 & MD30
Configuration options	Bench Top	Bench Mount or Cart
Primary pump type	Rotary vane pump DS-42 2 m ³ /hr (34 l/m)	Dry scroll pump DS-302 14 m ³ /hr (232 l/m) TS-620 30 m ³ /hr (500 l/m)
Minimum detectable leak at 1000 ppm ambient helium	5 x 10 ⁻¹² atm cc/sec: 5 x 10 ⁻¹² mbar l/s: 5 x 10 ⁻¹³ Pa m ³ /sec helium	
Maximum test port pressure	13 mbar, 10 Torr, 1330 Pa	
Helium pumping speed @ test port (fine test)	1.8 l/s	
Calibration routine	Automated or manual (internal or external)	
Background suppression	Push button initiated auto zero, and auto zero < zero function	
User interface	High clarity, color display, TFT touch screen	
Selectable languages	English, French, German, Japanese, Korean, Mandarin, Spanish	
Automated cycling	Programmable rough time, test time, reject set points	
Response time	< 0.5 seconds	
Set points	Standard, 5 set points, N/O or N/C; 3 leak rate, 1 pressure, 1 audio	
Communications interface	RS-232 isolated interface @ 9600 baud (DB-9S)	
Conformance standards	UL/CSA, CE	

Ordering Information			
Description		Shipping Weight kg (lbs)	Part Number
Pumps			
VS PR02 portable leak detector, DS 42 rotary vane pump	120 V	38 (83)	VSPR021
VS PR02 portable leak detector, DS 42 rotary vane pump	220 V	38 (83)	VSPR022
VS MR15 mobile leak detector, DS 302 rotary vane pump	120 V	81 (178)	VSMR151
VS MR15 mobile leak detector, DS 302 rotary vane pump	220 V	81 (178)	VSMR152
VS MD30 mobile leak detector, TS 620 dry scroll pump	120 V	92 (202)	VSMD301
VS MD30 mobile leak detector, TS 620 dry scroll pump	220 V	92 (202)	VSMD302
VS BR15 bench mount leak detector, DS 302 rotary vane pump	120 V	51 (112)	VSBR151
VS BR15 bench mount leak detector, DS 302 rotary vane pump	220 V	51 (112)	VSBR152
VS BD30 bench mount leak detector, TS 620 dry scroll pump	120 V	62 (137)	VSBD301
VS BD30 bench mount leak detector, TS 620 dry scroll pump	220 V	62 (137)	VSBD302
Factory Installed Options			
Oil mist eliminator for internal DS-42 (PR02 only)			VSFACME
Accessories			
1 $\frac{1}{8}$ in. compression test port			VSFLDCP
Sniffer probe, NW-25, 10 ft			K9565306

Support Plans – see page 258.

Additional options and accessories – see page 251 through 255.

VS Series Features and Benefits



Easy-to-Use – Two Button Operation

VS Series Leak Detectors combine the simplicity of two-button operation with advanced expert system intelligence.

- Fully automated start-up and calibration maximizes productivity
- Intuitive menu structure is easy to navigate
- Programmable test sequences improves testing efficiency
- Color touch screen provides excellent clarity, even at wide angles



Powerful – Broad Range of Test Methods

The state-of-the-art spectrometer and vacuum system design provides powerful capability, enabling a broad range of test methods for specific applications.

- High test port pressure allows for detection of large leaks
- 5×10^{-12} MDL (sensitivity) meets the most stringent leak test requirements
- High helium pumping speed ensures fast system response and clean-up times
- New high efficiency ion source and beam optics optimize sensitivity and mass separation



Versatile – Multiple System Configurations

A wide range of options allows for broad configuration flexibility, meeting all application requirements and test environments.

- Primary pump and system mounting options may be selected to best suit your needs
- Multiple language and units capability permits easy implementation worldwide
- Compact lightweight design enables easy transport from one application to another



Dependable – Robust Design

Robust design innovations allow the VS series to conform to the most rigorous industrial standards and operate dependably in the most challenging environments.

- Fast clean-up time enhances system up-time
- Robust Faraday cup technology delivers proven reliability with low cost of ownership
- Conforms to CE, UL and CSA standards, assuring global acceptance

VS Series Applications

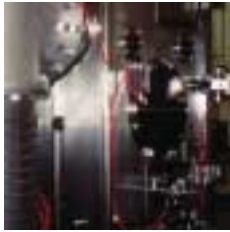

Industrial Process Tools

VS Series Leak Detectors can help rid your process tool of costly and inefficient leaks. Robust system features assure reliable operation in the most challenging industrial environments. Superior pumping characteristics such as high inlet pressure tolerance and split flow capability deliver fast response and clean-up times..

- Vacuum furnaces
- Coating systems
- EB welders



Power Generation

Leaks within power plant condensers can cause a significant loss of efficiency. High inlet pressure tolerance, auto-zero function, and the mobility of the two-wheel cart option simplify the leak detection process. Simple, intuitive operation allows intermittent use without excessive training requirements.

- Condensers
- Heat exchangers
- Steam circuits
- Underground pressured power cables



High Energy Physics

High sensitivity, large roughing capacity and portability are essential for leak testing accelerators and beam lines. These instruments provide excellent mass separation that differentiate the smallest helium leaks from residual water vapor and hydrogen and are available with large, dry roughing pumps to evacuate large volumes, or smaller internal pumps when used with a turbo pumping systems.

- Accelerators
- Beam lines
- Synchrotrons



Semiconductor Production

VS Series Leak Detectors combine high sensitivity and large, dry rough pumping capacity to meet the testing needs of semiconductor processing equipment and gas handling systems. With the high inlet pressure tolerance and fast clean up and response times, these units excel at locating leaks in both evacuated and pressurized systems.

- Process tools
- Gas panels
- Gas transfer lines



Small Parts Manufacturing

VS Series Leak Detectors employ high inlet pumping speed and high inlet pressure tolerance to minimize test cycle time, thereby maximizing production throughput. Programmable test sequences simplify daily operation, minimize operator error, and maximize your production efficiency.

- Automotive
- Electrical
- Refrigeration
- Hermetic packaging
- Medical & Implantable devices



General R&D

Research and university labs often require a portable leak detector with the versatility to cover a wide range of applications. The ability to be easily moved from lab to lab, in conjunction with high performance specifications in both the evacuation and pressurized mode, make the VS Series an essential tool for this environment.

- Electron microscopes
- Experimental chambers
- Surface analytical systems
- Space chambers



The 959 MacroTorr Helium Leak Detector fulfills the need for a rugged and dependable leak detector in the most demanding industrial applications. With its low initial price and low cost of ownership, this unit is the most cost effective leak detector available. It is available in stand-alone, bench-top, and two-wheel cart configurations. We have designed these units with large externally-mounted primary pumps that deliver high roughing speeds for fast pump down times. The bench-top and cart-mounted versions are available with Varian DS 302 rotary vane pumps or TriScroll™ 320 dry pumps.

- External mounting of large primary pumps results in fast pump down cycles
- High test port pressure tolerance reduces time required to reach test mode
- Available in wet and dry versions, on two- or four-wheel carts, or bench-top
- Simple, rugged design provides the cost effective solution for many applications

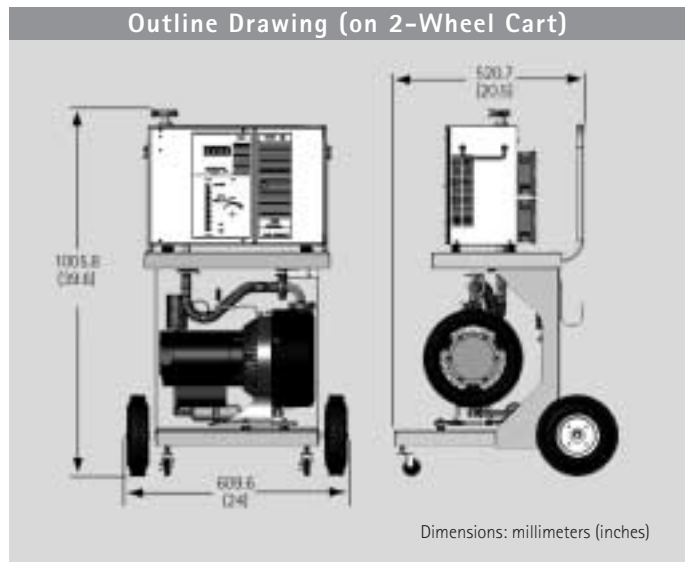
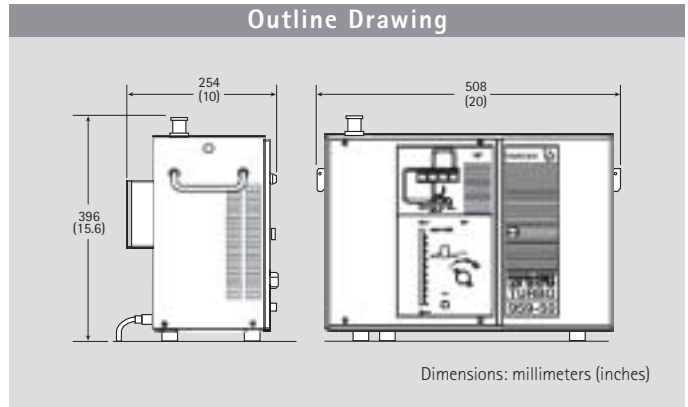

Technical Specifications

Sensitivity ranges	10 ⁻⁴ thru 10 ⁻⁸ atm cc/sec
Minimum detectable leak at 1000 ppm ambient helium	2 x 10 ⁻⁹ atm cc/sec helium
Maximum test port pressure	1 Torr
High Vacuum Pump	V70D MacroTorr turbo/drag pump
Primary Pump Type	Rotary vane pump
	Dry scroll pump
Inlet flange	NW-25 (optional 1 1/8" compression adapter)
Calibration routine	Manual
Background suppression	Manual
Leak indication	50 segment bar graph w/exponent display
Leak units displayed	Atmospheric cc/sec.
Ranging	Manual
Analog leak rate output (plug)	Phone jack, 0-5 VDC
Audio alarm	Threshold and volume control (103 dBA maximum @ 1 ft.) and output jack for remote speaker
Electronic response time	2 seconds
Recommended ambient operating temperature	5 to 35 °C
Power requirements	115 V or 230 V, 50/60 Hz (15/20 amps)
Weight, base unit	22.7 kgs (50 lbs)

Ordering Information

Configuration	Part Number			
	Base	x = Mounting	x = Sensitivity	xxx = Voltage
Stand-Alone (Pumps not Included)*	S9590000xxxxx	• 0 (None supplied)	• M = Standard Sensitivity	• 120 • 220
Single Rotary Vane Pump DS-302	L9593000xxxxx	• B = Bench • T = Two-wheel		
Single Dry Scroll Pump TS-320	D9593500xxxxx	• B = Bench • T = Two-wheel		
Description	Shipping Weight kg (lbs)		Part Number	
Accessories and Options				
Sniffer probe, NW25, 10' hose	1.8 (4)		K9565306	
Sniffer probe, NW25, 25' hose	1.8 (4)		K9565307	
Calibrated leak, external, NW25, 10 ⁻⁷ range (NIST-traceable)	1.8 (4)		F8473321	
Calibrated leak, external, NW25, 10 ⁻⁸ range (NIST-traceable)	1.8 (4)		F8473322	
Tuning leak/throttle valve, NW25	2.3 (5)		R1947301	
Spectrometer tube cleaning kit	1.4 (3)		670029096	
Replacement Parts				
O-ring kit	0.9 (2)		L6930301	
Ion Source, thoriated iridium	0.1 (0.2)		82850302	
Preamplifier, MacroTorr	0.5 (1)		L9030301	
Manual	1.4 (3)		699909745	

* 959 sensitivity is influenced by the speed of the system's primary pump. The above specifications are obtained with a nominal 10 cfm displacement pump.

For information on Support Plans, refer to page 258.

For information on pump options, refer to page 250.

For information on additional accessories and options, refer to pages 251 through 255.

990dCLDII



The 990dCLDII is a fully automated component leak detector comprised of a 19-inch rack-mounted control unit and a separate spectrometer unit. Additional features include a removable, remotely mountable front control panel, and complete valve control.

The 990dCLDII incorporates a modular connector system for simple installation of the spectrometer/turbo head and optional valve block assembly. Based on Varian's latest electronics architecture, the 990dCLDII offers a full array of control capabilities and performs automatic tuning and calibration routines.

The spectrometer assembly contains a dual thoriated filament ion source, analyzer assembly, detector with preamplifier, vacuum gauging, and the high-vacuum pump. Testing with

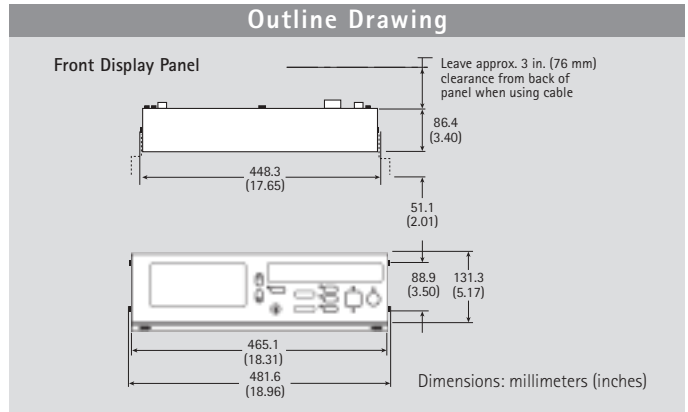

the 990dCLDII is accomplished by connecting a test fixture and valves to the foreline of the spectrometer's high vacuum MacroTorr Turbo pump.

- Component-based helium leak detectors offer added flexibility, speed, reduced size and cost savings in comparison with enclosed configuration models.
- Typical parts tested with helium mass spectrometer leak detectors during production are pressure sensors, automotive fuel and hydraulic components, airbag inflators, and air-conditioning and refrigeration coils.
- Offers rapid response and high sensitivity, as well as, embedded automatic calibration capability, computer interfacing, valve block interfacing, and remote diagnostics

Technical Specifications

	V70D	V70LP
High vacuum pump, turbo/drag pump		
Sensitivity ranges, <i>atm cc/sec</i> *	10 ⁻⁴ to 10 ⁻⁸	10 ⁻³ to 10 ⁻⁷
Minimum detectable leak at 1000 ppm ambient helium, <i>atm cc/sec helium</i> *	2 x 10 ⁻⁹	2 x 10 ⁻⁸
Maximum test port pressure, <i>Torr</i>	3	5
Calibration routine	Automatic/Manual	
Background suppression	Automatic and Auto Zero < Zero	
Leak indication	50 segment bar graph, log or linear and alphanumeric indication on LCD screen	
Leak units displayed	atm cc/second, mbar l/sec, Torr l/sec, Pa m ³ /second	
Ranging	Automatic	
Sensing tube	90 degree magnetic sector mass spectrometer	
Set points	Four (4)	
Communications interface (plug)	Host serial port, RS-232 interrupt driven (7 pin female). Diagnostic Serial Port (9 pin D Sub)	
Remote IO (plug)	Parallel Interface with discrete status outputs, opto-isolated inputs, 5-24VDC. Serial RS-232 @ 9600 baud (plug)	
Analog leak rate output (plug)	0-10 VDC Linear or logarithmic, 1, 2 or 3 VDC/ decade (plug)	
Audio alarm	Pitch controlled, dedicated volume control buttons, programmable audio threshold	
Noise level**	< 2% of most sensitive scale, peak-to-peak	
Internal response time, <i>seconds</i>	< 0.5	
Recommended ambient operating temperature	5 to 35 °C	
Power requirements	115, 230 VAC, 47 to 63 Hz, 3/1.5 A, 350 watts	
Weight, <i>kgs/lbs</i>	Control unit 12.25 (27); turbo/spectrometer tube assembly 7.71 (17)	
Conformance standards	Meets applicable CE, UL, CSA requirements	

* Specifications derived using a DS-302 Rotary Vane Pump with approximately three feet of one-inch diameter tube

**In accordance with AVS standard 2.1

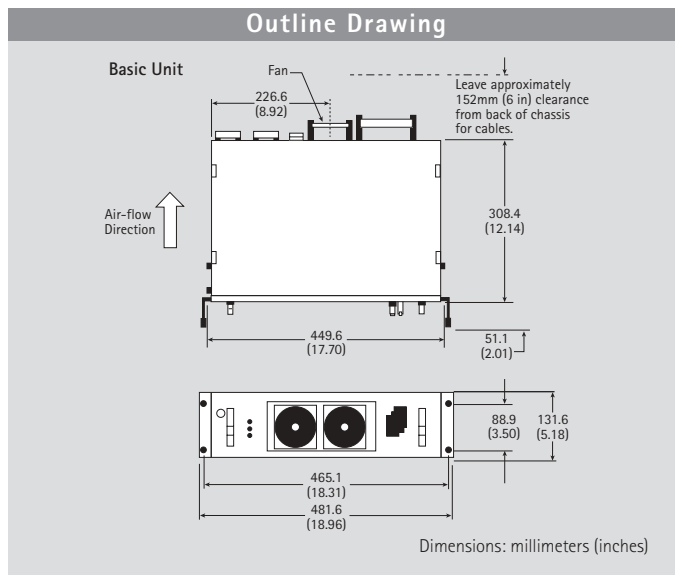
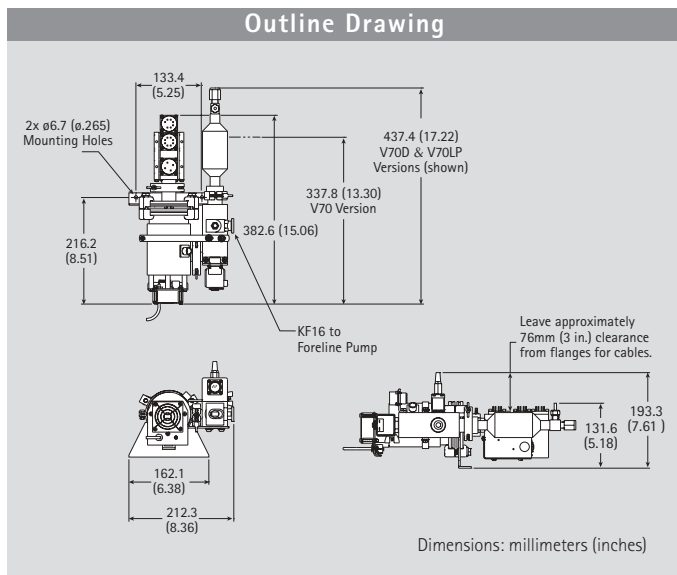

Ordering Information

Configuration	Part Number		
	Base	xx = Sensitivity	Voltage
990dCLDII Component Leak Detector Controller, Spectrometer Tube, and High Vacuum Pump included	D9902000xx	<ul style="list-style-type: none"> • LL = Standard Sensitivity • DL = High Sensitivity 	Voltage is selectable

Description	Shipping Weight kg (lbs)	Part Number
Cables		
Cable, spectrometer to controller, 5' (1.5 M)	2.7 (6)	R0623305
Cable, spectrometer to controller, 10' (3.0 M)	3.2 (7)	R0623310
Cable, spectrometer to controller, 15' (4.5 M)	3.6 (8)	R0623315
Cable, Valve Block Assembly, 5' (1.5 M)	0.9 (2)	R0632305
Cable, Valve Block Assembly, 10' (3.0 M)	0.9 (2)	R0632310
Cable, Valve Block Assembly, 15' (4.5 M)	1.4 (3)	R0632315
Cable, Front Panel Assembly, 5' (1.5 M)	2.2 (1)	R0634305
Cable, Front Panel Assembly, 10' (3.0 M)	2.2 (1)	R0634310
Cable, Front Panel Assembly, 15' (4.5 M)	2.2 (1)	R0634315
Options and Accessories		
Front panel assembly	3.2 (7)	R1114301

The Varian 990 Component Leak Detector includes the spectrometer tube, controller unit, and high-vacuum pump. Order interconnection cables and OPTO modules separately.

For information on Support Plans, refer to page 258.

For information on leak detector options and accessories, refer to page 251 through 255.

For information on roughing pumps, refer to page 250.

990CLD



The Varian 990CLD Component Leak Detector is a modular leak-testing package that can be integrated into virtually any testing system. The electronics module of the 990 can be separated from the sensing module and vacuum pumps by as much as 15-feet, permitting a high degree of flexibility in your system design.

Every 990CLD offers a variety of electronic interfaces making the setup of communications with a host computer, or Programmable Logic Controller (PLC), very convenient. This leak detector is an outstanding choice for precision leak detection in testing systems that incorporate helium leak testing.

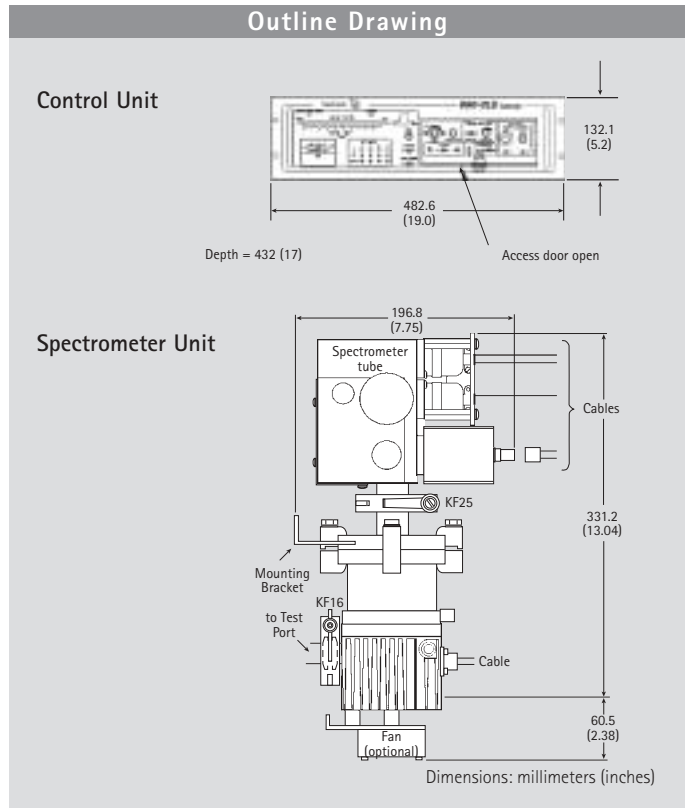

Technical Specifications

	V70D	V70LP
High vacuum pump, turbo/drag pump		
Sensitivity ranges, <i>atm cc/sec</i> *	10 ⁻⁴ to 10 ⁻⁸	10 ⁻³ to 10 ⁻⁷
Minimum detectable leak at 1000 ppm ambient helium, <i>atm cc/sec helium</i> *	2 x 10 ⁻⁹	2 x 10 ⁻⁸
Maximum test port pressure, Torr	3	5
Response time for helium, <i>seconds</i>	< 0.5	
Typical recovery time, <i>seconds</i>	< 3 seconds to recover from a 10 ⁻³ range leak	
Calibration routine	Manual	
Background suppression	Manual	
Leak indication	50 segment bar graph w/exponent display	
Leak units displayed	atm cc/seconds	
Ranging	Manual	
Set points	4 independent Form C dry contact leak rate set point: 250 VAC, 28 VDC, 6 amps, 180 watts inductive load, 1.8 KVA resistive load	
Remote IO (plug)	Opto-22 Input for optional remote filament on/off and display range control; Field-changeable 2.5-28 VDC, 35-60 VDC, 120 VAC, or 220 VAC; Form C dry contact outputs for pressure threshold, filament status, turbo status.	
Analog leak rate output (plug)	0-10 VDC, Linear or logarithmic 2-3 VDC/decade (plug)	
Electronic response time	< 0.5 seconds	
Power requirements	90-130 VAC or 180-240 VAC	
Weight (Base Unit), <i>kgs (lbs)</i>	Control unit 11 (24) Spectrometer unit 7 (15)	

* Specifications derived using a DS-302 Rotary Vane Pump with approximately three feet of one-inch diameter tube

Ordering Information

Configuration	Part Number		
	Base	xx = Sensitivity	xxx = Voltage
990 CLD Component Leak Detector Controller, Spectrometer Tube, and High Vacuum Pump included	L9900000xxxxx	<ul style="list-style-type: none"> • MT = High Sensitivity • LP = Standard Sensitivity 	<ul style="list-style-type: none"> • 120 • 220

Description	Shipping Weight kg (lbs)	Part Number
Cables		
Interconnecting cable, 5'	0.9 (2)	L9023305
Interconnecting cable, 10'	1.4 (3)	L9023310
Interconnecting cable, 15'	1.8 (4)	L9023315
Accessories and Options		
OPTO-22 module, 120 VAC	1.4 (3)	649150005
OPTO-22 module, 35-60 VDC	1.4 (3)	649150010
OPTO-22 module, 2.5 – 28 VDC	1.4 (3)	649150015
OPTO-22 module, 200 VAC	1.4 (3)	649150020
Tuning leak/ throttle valve, NW25	2.3 (5)	R1947301
Spectrometer tube cleaning kit	1.4 (3)	670029096
Universal test fixture, NW25	4.5 (10)	L6241306
Manual	1.4 (3)	699909690

The Varian 990 Component Leak Detector includes the spectrometer tube, controller unit, and high-vacuum pump. Order interconnection cables and OPTO modules separately.

For information on Support Plans, refer to page 258.

For information on additional accessories and options, refer to pages 251 through 255.

For information on roughing pumps, refer to page 250.

PHD-4

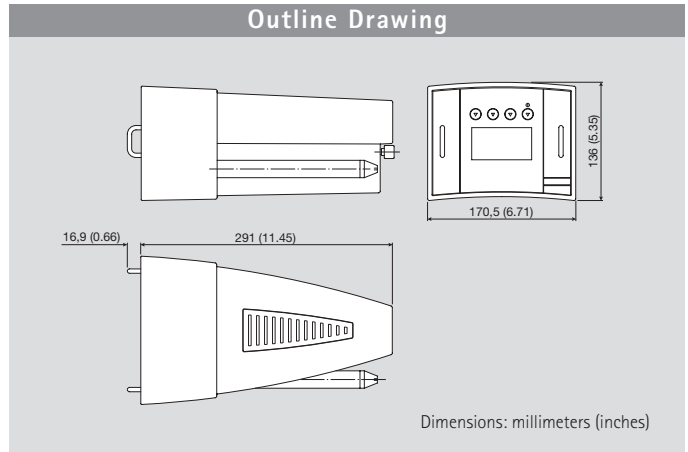

Wide Range, PHD-4 Portable Helium Detector

- High Sensitivity to Helium
- Easy to Use
- Truly Portable
- Versatile
- Dependable
- Thousands of portable SIPD sniffing helium detectors are in daily use worldwide
- testing provides proven application solution to a broad range of industries
- Native language application specialists available locally

Technical Specifications

Lowest Detectable Helium Concentration:	2 ppm (parts per million)		
Lowest Detectable Helium leak:	5 x 10 ⁻⁶ mbar l/s	5 x 10 ⁻⁶ atm cc/s	5 x 10 ⁻⁷ Pa m ³ /s
Response Time:	< 2 sec		
Recovery Time:	<10 sec (from 50 ppm to 0 ppm)		
Start up time, including self check-up:	3 min approx.		
Electrical Supply:	<ul style="list-style-type: none"> • Rechargeable Battery included • Power Supply included 		
Battery operation Time:	4 hours		
Maximum Signal Drift:	10 ppm/10 min		
Operating Conditions	Temperature: +5°C to +35°C	Humidity: 90% maximum relative humidity	
Storage Conditions	Temperature:	-20°C to +60°C	
	Weight:	2,6 Kg (5.7 lbs)	
Compliance to Norms:	CE, CSA/US approved		

Ordering Information

PHD-4 Complete Package	Part Number
Travel Case includes	9694640
<ul style="list-style-type: none"> • PHD-4 Basic Unit • Spare Battery • Transformer/Battery Charger (110-240V) • Carrying Strap • Probe Set • 15-pin I/O connector • CD Instruction Manual 	
PHD-4 Replacement Part Kit	Part Number
Includes	9694660
<ul style="list-style-type: none"> • Sampling Pump with Fittings • Probe with Sampling Line • Tip Probe Filter • Internal Filter (Kit of 5 units) 	
PHD-4 Basic Package	Part Number
Includes	9694600
<ul style="list-style-type: none"> • PHD-4 Basic Unit • Transformer/Battery Charger (110-240V) 	

- Carrying Strap
- 15-pin I/O connector
- CD Instruction Manual

Accessories	Part Number
• Probe Set	9693515
• Capillary leak with refillable reservoir and gauge	9693540
• Probe with 10 meter (30') maximum Sampling Line	9693525
• Telescoping Extension Probe	9693520
Individual Replacement Parts	Part Number
• Spare Battery	SR 03.702609
• Power Supply (110-240V)	SR 03.702888
• Sampling Pump with Fittings	SR 03.702513
• Probe with Sampling Line	SR 03.702538
• Tip Probe Filter	SR 28.900012-01
• Internal Filter (Kit of 5 units)	SR 03.702959
• Carrying Strap	SR 03.702791
• 15-pin I/O connector	SR 03.702894
• Travel Case	SR 03.702890

Contact Varian for Rack mounting or specific application requirements.

PHD-4 Features and Benefits



High Sensitivity to Helium – Can detect very small leaks

- High Sensitivity (2 ppm) to helium, three orders of magnitude better than industry standard, due to SIPD (proprietary and patented Selective Ion Pump Detection)
- Excellent selectivity for helium allows you to read helium leaks and ignore all other gases
- Helium sensitivity can be adjusted as required to minimize test costs and helium consumption
- Autozero function allows leak detection even in high helium background environment



Easy to Use – No training required

- State-of-the-art microprocessor control allows great simplicity of operation
- Fully automatic start-up
- Ready for test in less than 3 minutes
- Intuitive touch screen display
- Visual and audio indicators (standard headphone connection)
- No tuning required



Truly Portable – Compact and light

- The PHD-4 weighs only 2,6 Kg (5.7 lbs) including the battery
- Its compact size allows it to be easily carried anywhere
- Its ergonomic design allows comfortable use for extended periods



Versatile – Suitable for many different applications

- Wide range of uses: replaces or can be used with existing methods such as bubble test or pressure decay
- Able to detect both very small and large leaks
- Can operate either on battery power or connected to an outlet
- Displayed messages can be viewed in several languages (English, French, German, Italian).
- Standard Analog and RS232 Serial output.



Dependable – Long term operation

- Automatic backflow valve prevents helium saturation, ensuring fast response times as well as long life of sensing element.
- CE, CSA/US approved for global standardization.

PHD-4 Applications



Large Vessels and Bioreactors

The PHD-4 offers unmatched accuracy and repeatability, presenting a unique solution that it is cost effective and very well suited for the leak range specifications of this application. Biotech and pharmaceutical industries used to rely on pressure decay and bubble test methods for finding leaks in their large bioreactors. The PHD-4 has established a new standard of quality, significantly increasing production yields.

- Fermenters
- Sterilizers
- Freeze Dryers



Underground Pipes and Storage Tanks

The portability and light weight of the PHD-4 plays a major role in this application. Underground pipes and storage tanks (UST) are slightly pressurized with helium which, due to its high mobility, can escape through small leaks and migrate to the surface, where it can be easily detected by the PHD-4.

The accuracy, portability and light weight of this unit greatly simplifies this process, particularly in difficult construction sites or rough terrain.

- Gas distribution lines
- Under and above ground containers and storage tanks
- Telecommunication and high voltage underground cables



Courtesy of Fraunhofer UMSICHT, Germany

Water Heating and Cooling Pipes

The PHD-4 allows leak location without interruption of the normal operation, by mixing helium with the water in the circuit. Until recently, the precise and rapid location of leaks in buried pipes has been very difficult.

In the event of a leak, helium desorbs from the fluid and diffuses to the surface, where it is easily detected. Leaks in pipeline systems such as district heating systems, drinking or chilled water systems and steam pipe networks incur high costs due to losses and corrosion damage.

- Heater exchangers and steam condensation lines
- Water pipes
- Radiant heating systems



Airplane Fuel Tanks and Lines

PHD-4 technology is approved worldwide by airplane manufacturers and operators as the standard for the location of leaks in aircraft fuel tanks and in oxygen distribution lines.

For this purpose, helium is injected from the outside into the tank to be checked and the helium probe is used inside the wings to locate any leaks.

- Fuel tanks
- Oxygen distribution lines

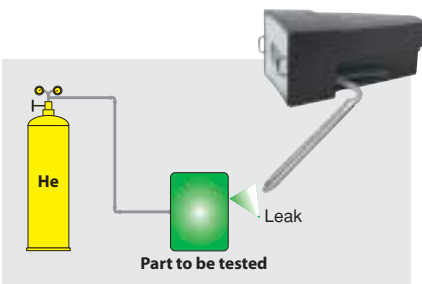

Other Applications

The PHD-4 is in daily use in many other applications. Virtually any object requiring any level of leak tightness can be simply tested with this instrument. Here is a partial list of other applications:

- Components and systems for the Chemical and Petrochemical Industries
- Components for the Automotive industry
- Process gas delivery lines in Semiconductor fabrication industry

Varian Pumps Designed for Leak Detection

Varian has the advantage of being a designer and manufacturer of both vacuum pumps and leak detectors. This gives us the proper insight for designing pumps that are perfectly suited for use in leak detection applications.

DS Series Rotary Vane Pumps

Leak detectors require pumps with the ability to quickly pump out the test piece while efficiently pumping and expelling helium from the system. Failure to do so limits leak detector performance. DS series pumps fulfill all the rigorous requirements of use in leak detection while delivering quiet, cool-running and dependable performance. DS Series Pumps:

- provide excellent helium pumping characteristics for stable leak rate signals
- employ forced oil-feed to remain cool even when pumping large volumes
- feature an anti-suck back valve to prevent migration of pump oil toward the leak detector

For technical information on rotary vane pumps, refer to Varian's Dual Stage Rotary Vane Pump catalog.

TriScroll Series Dry Scroll Pumps

For many applications, "dry" pumping is essential. In the past, dry pumps have had either low pumping speeds, poor base pressure, or both. Varian's TriScroll series pumps have revolutionized dry leak detection. With special design considerations implemented specifically for helium mass spectrometer leak detection, our dry pumps conform to rigorous standards without the potential for contamination. TriScroll pumps:

- provide high speeds for fast evacuation and cycle time
- deliver low base pressure for high sensitivity testing
- use no oil, avoiding contamination and oil disposal
- are optimized for helium pumping

For technical information on scroll pumps, refer to Varian's Dry Scroll Pump catalog.

MacroTorr Turbo and Turbo/drag pumps

The high vacuum pump in a mass spectrometer system is critical to a well-designed leak detector. These pumps need to deliver high pumping speed to keep the spectrometer tube at low pressure, while offering the correct helium compression ratios to allow for high sensitivity. In addition to offering all of the appropriate pumping characteristics, Varian's patented MacroTorr turbo and turbo/drag pumps require no periodic maintenance.

- MacroTorr design provides high inlet pressure tolerance
- optimized helium compression ratio permits optimal helium detection and fast signal clean-up
- permanently lubricated bearings need no maintenance

For technical information on turbo pumps, refer to Varian's Turbo Pump catalog.

Rotary Vane Pump – Outline Drawing

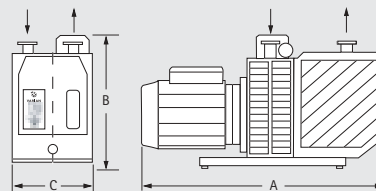

Pump	Pump Speed	A (length)	B (height)	C (width)	
DS-42	60 Hz	1.2 cfm	309 (12.0)	192 (7.5)	108 (4.2)
	50 Hz	1.8 m ³ /hr			
DS-302	60 Hz	8.2 cfm	467 (18.4)	212 (8.3)	132 (5.2)
	50 Hz	11.6 m ³ /hr			

TriScroll Pump – Outline Drawing

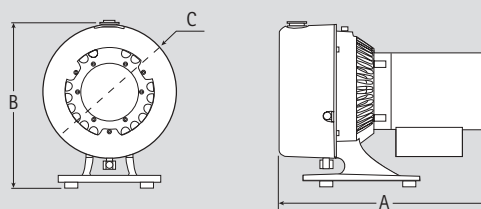

Pump	Pump Speed	A (length)	B (height)	C (width)	
TriScroll 620	60 Hz	17.7 cfm	471 (18.54)	355 (13.98)	300 (11.8)
	50 Hz	25.2 m ³ /hr			



Accessories and Options for Varian Leak Detectors

Atmospheric Gross Leak

L6839301 For 947/948

This option extends the gross leak testing range of the 947 and 948 leak detectors to a test port pressure of up to 1 atmosphere. The addition of this factory-installed option allows the user to find leaks as large as 10 std cc/sec at virtually any test port pressures up to atmosphere.

Calibrated Helium Leaks

Varian offers helium leaks traceable to NIST standards for use in calibrating your leak detector. An NW25 or 1 $\frac{1}{8}$ " OD tube fitting and isolation valve are provided as standard on the external leaks. The 10 $^{-6}$ /10 $^{-5}$ range reference helium leak includes a pressure gauge and refill port for evacuation and sniff test calibration.

External

NW25	Compression Port -1 $\frac{1}{8}$ "	
F8473325	F8473320	10 $^{-6}$ /10 $^{-5}$ std cc/sec range re-fillable sniffing/evacuation leak with pressure gauge and KF25 adapter
F8473321	F8473301	10 $^{-7}$ std cc/sec range, with valve
F8473322	F8473302	10 $^{-8}$ std cc/sec range, with valve
F8473323	F8473303	10 $^{-9}$ std cc/sec range, with valve
F8473324	F8473304	10 $^{-10}$ std cc/sec range, with valve

Internal, 1 $\frac{1}{8}$ " NPT Fitting (without valve)

K3264301 10 $^{-7}$ std cc/sec range

K3264302 10 $^{-8}$ std cc/sec range

Calibration

Calibration of existing leaks is done on an advance exchange basis. To order the recalibration service, simply add "GG" in front of the above part numbers.

Gas Line Testing Accessory

MSPA6415

The gas line testing accessory allows fast response evacuation leak detection of long (>30') gas lines. It is comprised of a male VCR (Cajon 4) cross with needle type purge flow valve and 10 $^{-9}$ atm cc/sec range calibrated leak. A pressure transducer is optional.

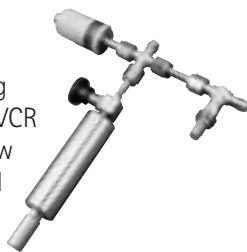

Helium Lecture Bottle Kit

L8856301

The Helium Lecture bottle provides a convenient supply of helium for leak testing. Measuring only 14" long and 2 $\frac{1}{2}$ " diameter, the bottle will provide enough helium for a full eight hours of leak testing at normal flow rates. The kit includes a Helium Lecture bottle containing 2 cubic feet of helium at 1800 psi, a pressure and flow regulator (P/N 642972175), and a helium spray probe kit (P/N K0167301) in one package.



Helium Spray Probe Kit

K0167301

For use in spraying helium to find the exact location of a leak. Three nozzles are included: a hypodermic nozzle for pinpointing leaks, a flexible tubing nozzle for hard-to-reach areas, and a long, soft copper nozzle that can be bent into almost any configuration to reach into deep crevices. An easy operating spring handle and 10 feet of hose with a female fitting simplifies attachment to the helium regulator.

Ion Source

82850301 Tungsten Ion Source

82850302 Thoriated Iridium Ion Source

GG82850301 Tungsten Ion Source (Rebuilt)

GG82850302 Thoriated Iridium Ion Source (Rebuilt)

Varian Ion Sources contain two prearranged filaments, a built-in header, and all appropriate mounting hardware in a single all-welded assembly. Varian offers both new and rebuilt ion sources. Rebuilt ion sources can be purchased on an advance exchange basis. Tungsten ion sources are available for older models; please refer to the product manual.



Leak Detection Handbook

699909070

The 135-page handbook, *Introduction to Helium Mass Spectrometer Leak Detection*, is useful for experts and novices. It covers leak detection fundamentals, helium leak detector types, equipment calibration, and product fixture design. A wide variety of process-specific application solution notes is also available.



Leak Detection Service Contracts

Varian offers a full range of preventive maintenance and comprehensive on-site support options for all of our leak detectors. See page 258.

Accessories and Options for Varian Leak Detectors (Cont'd)

Training Programs

Training courses for leak detector operation and maintenance are offered in regularly scheduled classes at our Palo Alto, California or Lexington, Massachusetts facilities. On-site training can also be provided at your plant. Contact your local sales engineer or see the training and service sections of this catalog.

See worldwide service and support on page 258.

See Leak Detector Training Programs on pages 256 and 257.

O-Ring Kit for Various Models

R0491301	979
L6749301	959 DP
L6930301	959 Turbo
9569901	956 DP
9569905	956 Turbo
L9346301	990 Valve Block
K7641801	938-41
K4372801	936 Series
L5669801	947/948/960

Each kit includes o-rings used throughout the leak detector, plus additional o-rings for test ports, spectrometer tube, and valves. These kits remove the risk of downtime associated with worn o-rings.

Power Probe

K9565301	Power Probe with 1 1/8" Test Port Adapter, 10' length
K9565302	Power Probe with 1 1/8" Test Port Adapter, 25' length
K9565306	Power Probe with KF25 Flange, 10' length
K9565307	Power Probe with KF25 Flange, 25' length
K9565303	Spare Tip Filters (10 each)

The Power Probe is a "sniffer" probe designed to locate leaks emanating from sealed containers internally pressurized with helium. The Power Probe adjusts for varying sensitivity and response time. It is extremely rugged and can be easily disassembled for cleaning. The probe kit includes 5 tip filters and is available with 10 or 25 feet of connecting tubing and an inlet adapter to fit on the leak detector. It is ideal for fast response sniffing with MacroTorr pumped leak detectors.



Preamplifiers

K3333301	956, 959 (DP and Turbo)
L9030301	959 (MacroTorr), 990 and 979 Standard Sensitivity
K9740301	947/948 and 960 (Collector Assembly)
R1003301	979 High Sensitivity

Spare preamplifiers and collectors are available for all portable and cabinet leak detector spectrometer assemblies. They are header-mounted and easily field-replaceable.

Remote Control Universal

L9558301	979 and 947/948/960 Platform Series
L9558302	947/948/960 Pre-platform Series



Spectrometer Tube Cleaning Kit

670029096 Kit with pre-saturated wipes and swabs
This Cleaning Kit contains clean wipes pre-saturated with Dow-Corning OS-20 solvent plus cotton swabs for cleaning in small holes or corners.

The kit is adequate for three spectrometer cleanings and can also be used for a variety of other vacuum applications.



Test Port Adapters and Kits

L8741301	1 1/8" Test Port to NW25 nipple adapter
L8741302	1 1/8" Test Port to NW40 nipple adapter
KCP401125	Adapter from NW40 to 1 1/8" compression fitting
LDCOMPINADKIT	Test Port Adapter Kit, to 1 1/8" compression fitting
LDNW25INADKIT	Test Port Adapter Kit, to NW25 fitting

Test Port Extension Manifold

K9799303 On request

The Test Port Extension Manifold provides a 1" (28 mm) ID quick coupling port on both the left side and the right side of the 947/948 or 960 leak detector. The standard test port is still available for use with the extension manifold attached.

Throttle Valve, for 1 1/8" Compression Port

626603345

The Varian throttle valve is a manually operated, NW25 to 1 1/8" tubulated variable conductance device used to control the flow of gas to the leak detector. It is frequently used in leak detector applications in which a grossly leaking part or vacuum chamber will not permit the leak detector to go into the test mode. The throttle valve is a non-quantitative approach to locating very large leaks in your vacuum system.



Tuning Leak, for 1¹/₈" Compression Port K1608301

The Tuning Leak consists of a ten-segment calibrated needle valve which can be used as an aid to gross leak testing or for gross leak calibration. The Tuning Leak can be used with any Varian Leak Detector and can also provide an indication of background helium in the testing area.



Throttle/Tuning Leak Valve with NW25 Fitting R1947301

For leak detectors with an NW25 inlet, the tuning leak and throttle valves have been combined into one product. This valve performs the same functions as the two described above.

Turbo and Dry Upgrades

Varian can factory-upgrade your existing 938, 956, 959, 947, 948, 960, and 979 series leak detectors into turbo or totally dry pumped configurations. Compared to diffusion pumped leak detectors, turbo pumping improves the spectrometer cleanliness and service life, while being more tolerant to higher test pressures. Dry leak detectors also feature scroll-type roughing and fore pumps that provide totally hydrocarbon-free operation for sensitive parts and systems. They also feature the convenience of not having to check, add, or dispose of pump fluids.

Universal Test Fixture Option (Flapper Box)

L6241301 947/948 Series, 1¹/₈" Compression Port
L6241305 979 Series, 1¹/₈" Compression Port
L6241306 979 Series, NW25

This leak detector option makes leak testing of small parts almost totally automatic and very fast. With this option, the total time to test a typical integrated circuit or other small device is less than six seconds. The fixture is clamshell-shaped with tapered walls and a spring-loaded lid. The fixture can be used with the Automatic Sequencer feature in Models 947/948/960 or 979 in order to fully automate and quicken the test cycle. Size: 4" ID x 1" deep. An insert is supplied to reduce the size to 3.25" ID, tapered to 2.83" x 3/4" deep.

Probe Set, PHD-4

9693515

This set consists of three different probe tips that can replace the standard tip for specific applications. One tip has a smaller diameter for more precise leak location. A second is more flexible, for easy access to difficult areas, and a third is for general use.

Capillary Leak with Refillable Reservoir, PHD-4 9693540

This capillary leak is useful to monitor proper operation of the PHD-4, ensuring that it is sensitive to helium at all times. The probe tip can be simply inserted in the capillary outlet and a signal of given value is displayed on the front panel. The helium reservoir can be refilled from a helium source.

Probe with 10m (30') Sampling Line, PHD-4 9693525

For applications in which the length of the standard probe is not adequate, a probe extension is available. It has a maximum length of 10m, but may be cut to shorter lengths.

Telescoping Extension Probe, PHD-4 9693520

This probe assists the operator when additional rigid length is required, as when checking underground objects, or objects beyond arms length. The tip has a small funnel to better convey helium to the probe.

Oil Mist Eliminator for Internal DS-42, VSPR02 VSFACME

The mist eliminator may be applied to the internal DS-42 backing pump, if oil mist is undesirable. **(Factory installed.)**

1¹/₈" Compression Test Port, VS Series VSFLDCP

The compression port permits the use of accessories and fixtures with tube terminations that you may have purchased previously.

Accessories and Options for Varian Leak Detectors (Cont'd)

Ordering Information								
Description	Part Number	VS	PHD-4	979	959	947/948	960	990
Atmospheric Gross Leak Option for 947/948	L6839301					•		
Collector Assembly for 947/948 and 960	K9740301					•	•	
External Calibrated Helium Refillable Leak, 1 1/8" Comp., 10 ⁻⁶ /10 ⁻⁵ std cc/sec	F8473320	•		•	•	•	•	•
External Calibrated Helium Refillable Leak, NW25, 10 ⁻⁶ /10 ⁻⁵ atm cc/sec	F8473325	•		•	•	•	•	•
External Calibrated Helium Leak, 1 1/8" Comp., 10 ⁻⁷ atm cc/sec	F8473301	•		•	•	•	•	•
External Calibrated Helium Leak, NW25, 10 ⁻⁷ atm cc/sec	F8473321	•		•	•	•	•	•
External Calibrated Helium Leak, 1 1/8" Comp., 10 ⁻⁸ atm cc/sec	F8473302	•		•	•	•	•	•
External Calibrated Helium Leak, NW25, 10 ⁻⁸ atm cc/sec	F8473322	•		•	•	•	•	•
External Calibrated Helium Leak, 1 1/8" Comp., 10 ⁻⁹ atm cc/sec	F8473303	•		•	•	•	•	
External Calibrated Helium Leak, NW25, 10 ⁻⁹ atm cc/sec	F8473323	•		•	•	•	•	•
External Calibrated Helium Leak, 1 1/8" Comp., 10 ⁻¹⁰ atm cc/sec	F8473304	•		•				
External Calibrated Helium Leak, NW25, 10 ⁻¹⁰ atm cc/sec	F8473324	•		•			•	
Fast Sniff Tester – External Attachment, 115 V, 1 1/8" Compression Port	L6539301				•	•		
Gas Line Testing Accessory	MSPA6415			•	•	•		•
Handbook of Leak Detection	699909070			•	•	•	•	•
Helium Lecture Bottle with regulator and spray probe kit	L8856301			•	•	•	•	
Helium Spray Probe (order regulator separately)	K0167301			•	•	•	•	
Internal Calibrated Leak, 10 ⁻⁷ atm cc/sec range	K3264301			•		•		
Internal Calibrated Leak, 10 ⁻⁸ atm cc/sec range	K3264302			•		•	•	
Ion Source, Thoriated Iridium (New)	82850302			•	•	•	•	•
Ion Source, Thoriated Iridium (Rebuilt)	GG82850302			•	•	•	•	
Ion Source, Tungsten (New)	82850301				•			
Ion Source, Tungsten (Rebuilt)	GG82850301				•			
O-Ring Kit for 979	R0491301			•				
O-Ring Kit for 947/948/960	L5669801					•	•	
O-Ring Kit for 959 DP	L6749301				•			
O-Ring Kit for 959 Turbo	L6930301				•			
O-Ring Kit for 956 DP	9569901							
O-Ring Kit for 956 Turbo	9569905							
O-Ring Kit for 990 Valve Block	L9346301							•
O-Ring Kit for 938-41	K7641801							
O-Ring Kit for 936 Series	K4372801							
O-Ring Kit for 947/948/960 DP	L5669801				•	•		
Power Probe Sniff Accessory – 1 1/8" Fitting, 10'	K9565301			•	•	•	•	
Test Port Nipple, NW25 on 1 1/8" OD Tube	L8741301			•	•	•	•	
Test Port Nipple, NW40 on 1 1/8" OD Tube	L8741302			•	•	•	•	
Test Port Adapter Kit, 1 1/8" Compression Fitting	LDCOMPINADKIT			•	•			
Test Port Adapter Kit, NW25 Fitting	LDNW25INADKIT			•	•			
Power Probe Sniff Accessory – 1 1/8" Fitting, 25'	K9565302			•	•	•	•	

Ordering Information								
Description	Part Number	VS	PHD-4	979	959	947/948	960	990
Power Probe Sniff Accessory – KF25 Fitting , 10'	K9565306			•	•			•
Power Probe Sniff Accessory – KF25 Fitting , 25'	K9565307			•	•			
Preamplifier Assembly – 959 (Turbo), 938-41, 936 Series	K3333301			•		•		
Preamplifier Assembly – 959 (MacroTorr) and 990	L9030301							•
Preamplifier Board – 947/948 and 960	K9765301					•	•	
Preamplifier Assembly – 979 Standard Sensitivity	L9030301			•		•	•	
Preamplifier Assembly – 979 High Sensitivity	R1003301			•				
Remote Module for 947/948/979 (new platform)	L9558301			•		•	•	
Remote Module for 947/948/960 (old electronics)	L9558302			•		•	•	
Spectrometer Tube Cleaning Kit	670029096			•	•	•	•	•
Test Port O-Ring (2-216)	660892216							
Test Port Conversion Kit, 1 1/8". Test Port to NW25	L8741301			•	•	•	•	
Test Port Conversion Kit, 1 1/8". Test Port to NW40	L8741302			•	•	•	•	
Test Port Extension Manifold*	K9799303					•	•	
Tip Filters for Power Probe Sniffer (10 each)	K9565303				•			
Throttle Valve	626603345			•	•	•	•	
Valve Block, Basic Unit, 990 Series	L9085301							•
Valve Block, Complete, Standard Version, 990 Series	L9085302							•
Valve Block, Complete, Stainless Version, 990 Series	L9085303							•
Probe Set	9693515		•					
Capillary Leak with Refillable Reservoir	9693540		•					
Probe with 10 m (30') Sampling Line	9693525		•					
Telescoping Extension Probe	9693520		•					
Oil Mist Eliminator for Internal DS 42	VSFACME	•						
1 1/8" Compression Test Port	VSFLDCP	•						

* Factory-installed option only

For further information, contact our technical support staff.



Course Description

Leak Detection Applications & Techniques is a two-day course designed as an introduction to helium mass spectrometer leak detection. Excellent for equipment operators, this intensive two-day course addresses the advantages and limitations of various leak detection techniques and explores ways to get the best performance from a helium mass spectrometer leak detector. Operation, tuning, and calibration of the detector are covered in practical laboratory sessions. Leak detection methods designed to solve various problems and system configurations are discussed and demonstrated.

Upon completion of the course the student will be able to operate, tune, and calibrate a leak detector. The student will understand the basic operating principles of helium leak detection and will learn how to perform several different methods of leak detection correctly.

Class size is limited to 16 attendees

Recommended Prerequisite: Basic Vacuum Practice

Course Outline

Leak Detection Theory

- Review of basic vacuum concepts
- Leak detector vacuum systems
- How the spectrometer tube works
- How leak rates are measured

Leak Detector Operation

- Description of controls
- Tuning & calibration
- Leak rate meter reading

Test Procedures

- Fine test procedures
- Gross leak procedures
- Component leak checking
- System leak checking
- Helium sniffing

Leak Detector Maintenance

2 Day and 3 Day

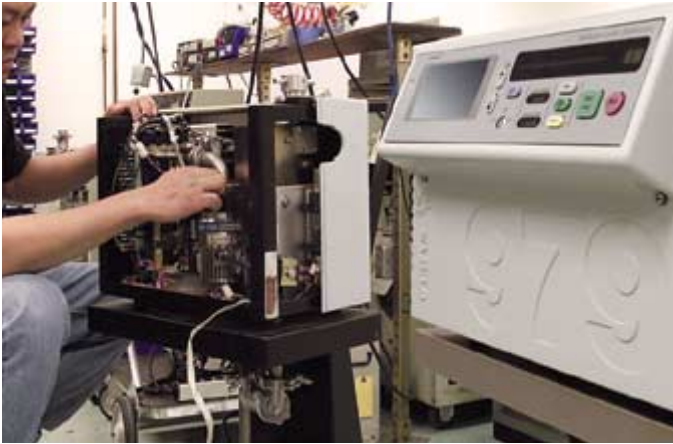

Course Outline

- Review of basic vacuum concepts
- Vacuum & leak detection review
- Leak detector setup and operation
- Spectrometer tuning
- Leak detector calibration
- Ion source replacement
- Spectrometer tube cleaning
- High vacuum pump maintenance
- Mechanical pump maintenance
- Valve block and manifold maintenance
- Basic troubleshooting

Course Description

Varian's Leak Detector Maintenance training is designed to provide personnel responsible for the maintenance of leak detectors with the ability to correctly configure, operate, and perform routine maintenance procedures on supported Varian leak detectors. Training is available for the following Varian leak detector models: 938, 947, 948, 956, 959, 960, 979, and 990.

Varian offers Leak Detector Maintenance training on supported Varian leak detectors through three separate types of training programs: regularly scheduled Leak Detector Maintenance courses; On-Request Leak Detector Maintenance training offered at our training facilities in Lexington, MA and Palo Alto, CA (USA); and On-Site Leak Detector Maintenance training delivered at customer facilities world-wide.

2-Day Course

Leak Detector Maintenance for Varian portable and component models 938, 956, 959, 979 and 990 leak detectors is a 2-day course, and includes training on remote operations using the RS232 communication protocol.

3-Day Course

Leak Detector Maintenance for Varian cabinet model 947, 948 and 960 leak detectors is a 3-day course and includes training on the hand-held communication pendant and remote operation using the RS232 communications protocol.

Class size is limited to 10 attendees

Required Prerequisite: Basic Vacuum Practice

Recommended Prerequisite: Leak Detection Applications & Techniques

For more detailed information on training schedules and customized courses, please see the Training section of our catalog, or contact Varian at 800.882.7426.

Worldwide Service and Support

Maximizing Your Productivity and Uptime

Varian Inc. has gained an industry leading reputation for service worldwide. We offer flexible and comprehensive support plans, and provide the most extensive network of service engineers available, delivering applications assistance, start-up support, vacuum and leak detection training, maintenance and calibration.

Why consider a Leak Detector Support Plan?

Maintaining your leak detector often means choosing between your internal maintenance organization and an external service provider. Internal maintenance requires investment in staff, training and inventory. Varian can provide comprehensive on-site and factory support agreements tailored to your needs. With Varian's preventive maintenance services, you know that all work is done by factory-trained service technicians with backup support from our factory based product engineers. You can count on your leak detector remaining in optimal working condition, and your maintenance expenses are known in advance. If you choose factory service, Varian guarantees a turnaround of three business days after receiving the unit.

Varian Leak Detector Support Plans

The Basic Warranty provides coverage for the cost of parts and labor associated with replacement or repair of defects in material or workmanship during the initial twelve months after purchase of the leak detector. Basic Warranty for all leak detector models is included with the purchase of each new unit and includes twelve-month warranty coverage for the cost of parts and labor associated with replacement or repair of defects in material or workmanship.

The Basic On-Site Warranty provides coverage for all items described above except that warranty issues will be handled at the customer site rather than at a Varian facility. Basic On-Site Warranty for all portable and mobile models can be purchased with each new unit.

Second Year Warranty Support Plans are available for customers who wish to extend coverage for an additional twelve months, and have trained Varian personnel provide the required preventive maintenance either on-site or in our factory. Customers who select second year plans can accurately budget maintenance expenses for this period. These plans must be purchased with the leak detector, and include one scheduled preventive maintenance overhaul (performed during the second year), applicable software upgrades, informal operator training, and exchange of the calibrated leak to permit ISO9001 conformance.

Preventive Maintenance Support Plans are also available for customers who wish to have Varian personnel provide the required maintenance. These plans can specify service on-site or in a Varian factory, and cover all expenses incurred in maintaining the equipment as required. Travel expenses of Varian personnel are included, if the customer chooses on-site service. Preventive Maintenance Support Plans include one scheduled preventive maintenance overhaul, applicable software upgrades, informal operator training, and exchange of the calibrated leak to permit ISO9001 conformance. Plans may be ordered for any Varian leak detector in operating condition subject to initial paid inspection by a Varian field sales engineer or factory technician.

Customized plans are also available. Please contact us to learn more.

Note: 990 models are serviced by means of an advanced exchange program. Please call for more details.

Leak Detection Reference Library

**Vacuum Technologies General Catalog on CD**

CD compilation of the complete catalog of vacuum products and services from Varian, plus a user-friendly interactive catalog of our extensive offering of primary, high, and ultra-high vacuum pumps, rich with information on applications, methods, and recommended equipment.

**Basic Vacuum Practice, Third Edition****Order part number 9000085**

Comprehensive vacuum training textbook used in our Basic Vacuum Practice courses, chock full of helpful information presented in a clear, graphically rich format, useful for the newcomer to vacuum practice as well as the experienced technician.

**High Vacuum Technology: A Technical Guide, Second Edition, Marsbed H. Hablanian****Order part number 699901000**

Complete reference guide to designing, building, and maintaining high vacuum systems with detailed sections on all aspects, including the nature and uses of vacuum; properties and laws of gases; system considerations including materials, out-gassing, and conductance; the principles of each major rough and high vacuum pumping technology; achieving ultra-high vacuum; and measuring and controlling pressure. A detailed section on leak detection included.

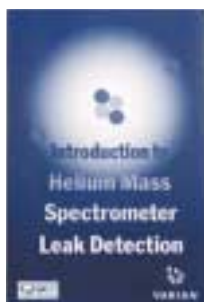
**Introduction to Helium Mass Spectrometer Leak Detection****Order part number 699909070**

The definitive guide to mass spectrometer leak detection provides detailed information on fundamentals and methods of leak detection, elements of the leak detection instrument, tuning and calibration, product and fixture design, and many specific applications. Extensive bibliography, glossary, and reference information included.

**Leak Detection Application Notes**

Concise descriptions and guides to the use of helium mass spectrometer leak detection in specific applications.

Available in print or on-line at www.varianinc.com

Please contact Varian to request copies of any of the above.

Design and Application Considerations

The Effect of Helium Pumping Speed

Detecting a leak quickly is one of the most important requirements in using a helium leak detector or a leak detection system. This requirement is characterized by the following elements:

- Response time
- Appearance time
- Disappearance (cleanup) time

1. Response time

Response time is defined as the time required for a leak detector to measure 63% of the peak helium signal. This response time is based on an exponential behavior (Figure 1). This shows the appearance of a 10^{-7} std. cc/sec leak signal.

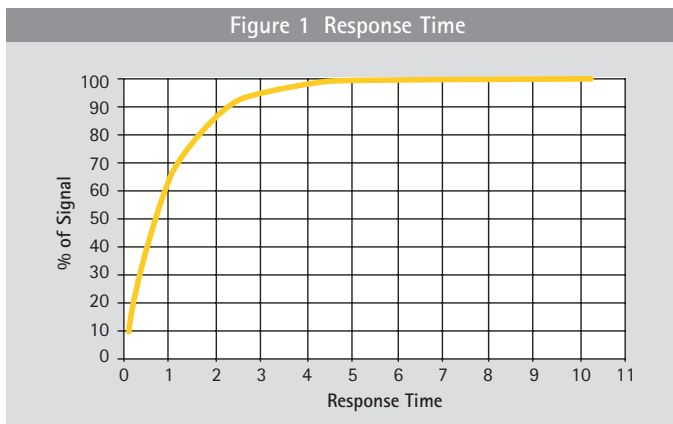

In order to quickly measure the signal in a vacuum application, the response time should be as short as possible. In general, a larger test volume will yield a slower response time. Also, a test volume connected to the detector by a long, narrow tube will negatively affect the response time, since helium must travel through the tube to the detector.

For a given volume, the effective pump speed of the leak detector or leak detection system must always be as large as possible. To optimize cycle time, for example in a production application, auxiliary pumps can be used to obtain the desired objectives. These pumps must be sized and correctly integrated to yield maximum effectiveness.

2. Appearance time

Appearance time is the time required to see an increase of signal, above the background level, after helium is admitted to a leak. Appearance time is only a first indication of a leak and does not indicate the eventual magnitude of the leak rate. This is different from response time, which is calculated from the peak value. The first "appearance" of a leak is often sufficient to stop a test cycle before a test chamber becomes saturated with helium, thus avoiding a lengthy cleanup period. In some applications, it is sufficient to know that there is a leak without

knowing the actual magnitude of the leak and the full response time. The outstanding background subtraction capabilities of Varian's VS series helium leak detectors is of great importance in improving appearance time.

3. Disappearance time.

Disappearance time (cleanup time) is the time required for a leak detector to recover to a desired sensitivity after exposure to a leak. Here one will observe the most noticeable time difference between a high performance and low performance leak detection system arrangement. A high pumping speed will yield significantly faster cleanup times.

Selecting the Proper Connections

In most situations when using the Outside-in Vacuum Method, it is necessary to install a connection between the leak detector and the part or chamber to be evacuated. Sizing this connection is an important aspect of the leak detection system performance because, 1) the connection adds volume to the total system arrangement, and 2) it restricts the helium pumping capability of the leak detector system.

Selecting an inappropriate connection line can alter the capabilities of a leak detector system. For example, a tube of 4 feet in length by 0.40 inches in diameter has a conductance of 0.27 l/s for helium in molecular flow (Figure 2). This means that even the most powerful helium leak detector will not deliver a pumping speed higher than 0.27 l/s. Using this value in the calculations provided for response time, appearance time, and disappearance time will clearly demonstrate the impact of limited conductance.

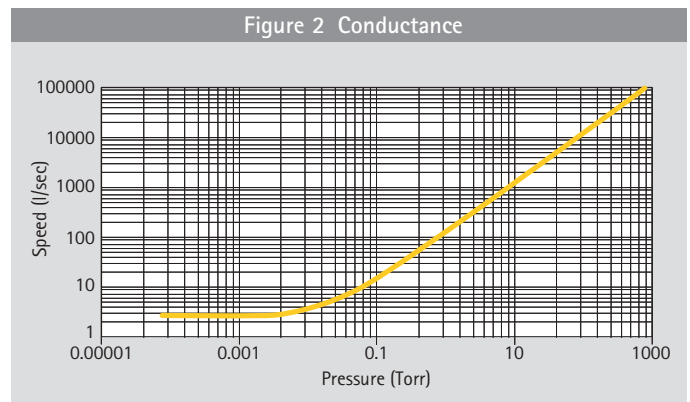

The Evacuation Process

In order to leak test a part by the Outside-in Vacuum Method, it is necessary to evacuate the part or the chamber in which the part is placed. The required vacuum level will depend on the acceptable leak rate requirements. (See section on helium background, page 261.)

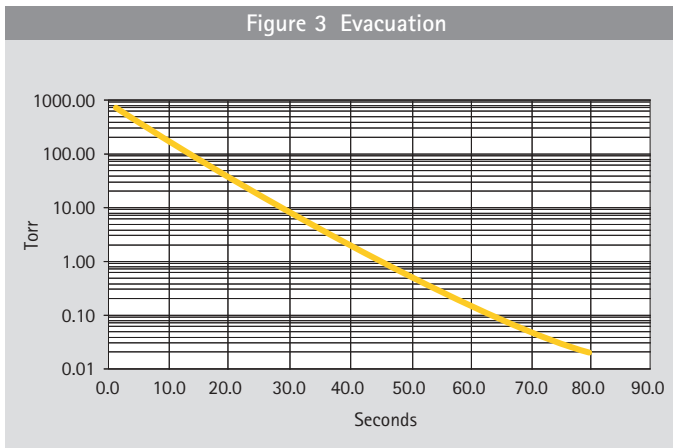

To reach the appropriate level in a timely fashion, it is necessary to select a pumping system based on the right pump characteristics, pumping speed and base pressure, as well as the right manifolds arrangement, conductance limitations and added volume considerations.

When purchasing a self contained helium leak detector that is equipped with its own roughing pump, special attention should be paid to the size of the pump to avoid the need for purchasing auxiliary pumps, manifold, or control equipment.

Appropriate Helium Background Conditions

As shown in Figure 4, helium is present in ambient air at 5 parts per million (ppm). Although this is a very low level when looking for leaks as small as 10^{-9} std. cc/sec, helium background remains an issue.

Gas	Symbol	% by Volume	PPM
Nitrogen	N ₂	78.08	780800
Oxygen	O ₂	20.95	209500
Argon	Ar	0.93	9300
Carbon Dioxide	CO ₂	0.03	300
Neon	Ne	0.0018	1
Helium	He	0.0005	5
Krypton	Kr	0.0001	1
Hydrogen	H ₂	0.00005	0.5
Xenon	Xe	0.0000087	0.087

When testing by the Outside-in Vacuum Method, correct evacuation conditions and proper spraying technique, combined with adequate ventilation, are key to maintaining proper detector system operation. Proper charging, venting and careful release of the helium after a test are critical in testing by the Inside-out Sniffing Method.

Varian's VS series leak detectors are equipped with unique helium background suppression features that allow compensation of >2 decades of helium background (Floating Zero).

Parallel Operation

If the volume of the part to be tested is very large or the cycle time very short, an auxiliary pumping station may be required operating in parallel with the leak detector (see Figure 5). In this situation, the auxiliary pump or pumping station is used for roughing only.

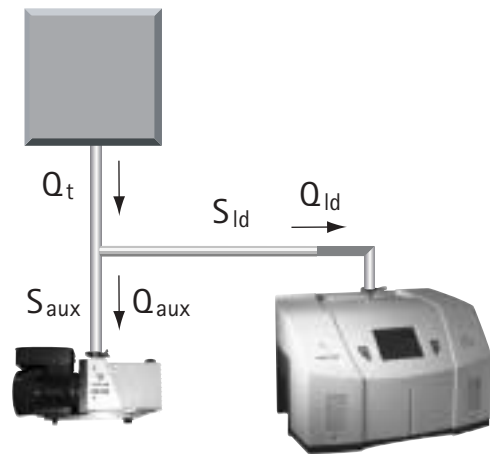

Figure 5 Parallel Operation

Calculation of response time, appearance time, and disappearance time must be considered in both the effective helium pumping speed provided by the detector and the effective helium pumping speed provided by the auxiliary pump at the chamber. The total helium flow (Q_t) coming through a leak and through the chamber will be split in a flow (Q_{ld}) towards the detector and flow (Q_{aux}) towards the auxiliary pump. This will result in a decrease of the indicated leak rate at the leak detector, which must be compensated for.

Helium Consumption

Based on the attainable sensitivity using the helium leak detection method, parts to be tested may be charged with a helium/gas mixture to reduce the helium consumption. This is especially true for large parts or production type testing. Lower Helium consumption may also be achieved by raising the pressure inside the part to be tested, while lowering the concentration. The effect will vary depending on the flow conditions of the actual leak.

Leak Detectors

Equations for Use in Helium Leak Detection

Response time in molecular flow:

$$t_{63} = \frac{V}{S}$$

With: t = Time in seconds to 63% of full signal
 V = Volume in liters
 S = Helium pumping speed in l/s

**Molecular flow conductance-circular tube
 (for N₂ at room temperature):**

$$C = 12 \times \frac{D^3}{L}$$

With: C = Conductance in l/s
 D = Tube diameter in cm
 L = Tube length in cm

Appearance time in molecular flow:

$$t_a = \frac{V}{S} \times 2.3 \times \log \frac{Q}{Q - Q_m}$$

With: t_a = Appearance time in seconds
 V = Volume in liters
 S = Helium pumping speed of the detector in l/s
 Q = Leak rate in mbar.l/s
 Q_m = Smallest detectable leak in mbar.l/s

Split flow calculations:

$$(Q_{ld}) = \frac{(S_{ld})}{(S_{ld}) + (S_{aux})} \times (Q_t)$$

With: (Q_{ld}) = Helium flow towards the leak detector
 (Q_t) = Total helium flow from the chamber towards the LD + auxiliary pump
 (S_{ld}) = Helium pumping speed of the leak detector
 (S_{aux}) = Helium pumping speed of the auxiliary pump

Disappearance time in molecular flow:

$$t_d = \frac{V}{S} \times 2.3 \times \log \frac{Q}{Q - Q_m}$$

With: t_d = Disappearance time in seconds
 V = Volume in liters
 S = Helium pumping speed of the detector in liters/second
 Q = Leak rate in mbar l/sec
 Q_m = Smallest detectable leak in mbar.l/s

Gas loss under viscous flow conditions:

$$Q = \frac{R}{M} \times \frac{22400}{365 \times 24 \times 3600} \times \frac{T}{273}$$

With: Q = Leak rate in mbar l/s
 R = Gas loss in grams/year
 M = Molecular weight gas
 T = Temperature in degrees Kelvin
 22400 = Volume of one mole of gas at 273 °K and 1 atm in cc
 365 x 24 x 3600 = seconds in one year

Evacuation time:

$$t = \frac{V}{S} \times 2.3 \times \log \frac{P_1}{P_2}$$

With: t = Evacuation time in seconds
 V = Volume in liters
 S = Pumping speed in l/s
 P_1 = Beginning pressure in mbar
 P_2 = Ending pressure in mbar

Gas flow under viscous flow conditions:

$$Q = \frac{3.14 \times D^4}{256 \times \text{visc}} \times L \times (P_1^2 - P_2^2)$$

With: Q = Leak rate in mbar l/sec
 D = Leak diameter in cm
 L = Length of the leak in cm
 visc = viscosity of the gas in bar s
 P_1 = Absolute pressure one side of the wall in bar
 P_2 = Absolute pressure other side of the wall in bar

Viscous flow conductance-circular tube:

$$C = 182 \times \frac{D^4}{L} \times P$$

With: C = Conductance in l/s
 D = Tube diameter in cm
 L = Tube length in cm
 $*P_1$ = Upstream pressure in mbar
 $*P_2$ = Downstream pressure in mbar
 $*P$ = average pressure $(P^0 + P_f)/2$ in mbar

Gas flow under molecular flow conditions for long cylindrical tube:

$$Q = \frac{1}{6} \times \sqrt{\frac{2 \times 3.14 \times R \times T}{M}} \times \frac{D^3}{L} \times (P_1 - P_2)$$

With: Q = Leak rate in mbar l/sec
 L = Length of the leak in cm
 D = Leak diameter in cm
 M = Molecular weight gas
 R = Gas constant (8.3 E7)
 T = Temperature in degrees Kelvin
 P_1 = Absolute pressure one side of the wall in bar
 P_2 = Absolute pressure other side of the wall in bar

Conversion Tables

Pumping Speed				
	cfm	l/minute	l/sec	m ³ /hour
1 cfm	1	28.32	0.472	1.6977
1 l/minute	0.035	1	0.016	0.06
1 l/sec	2.12	60	1	3.6
1 m ³ /hour	0.589	16.67	0.27	1

Flow/Leak Rate					
	atm cc/sec	mbar l/sec	torr l/sec	Pa m ³ /sec	sccm
1 atm cc/sec	1	1	0.76	0.1	60
1 mbar l/sec	1	1	0.76	0.1	60
1 torr l/sec	1.3	1.3	1	0.13	80
1 Pa m ³ /sec	10	10	7.5	1	600
1 sccm	0.016	0.016	0.0125	0.0016	1

Pressure						
	Torr	mbar	Pa	micron	psi	atm
1 Torr	1	1.33	133	1000	0.0193	0.00132
1 mbar	0.751	1	100	750	0.014	0.0009
1 Pa	0.00751	0.01	1	7.5	0.00014	0.000009
1 micron (mTorr)	0.001	0.0013	0.13	1	0.000019	0.0000013
1 psi	51.72	68.96	6896	51710	1	0.07
1 atm	760	1013	101300	760000	14.7	1

Volume					
	inch ³	ft ³	liter	cm ³	m ³
1 inch ³	1	0.00056	0.0163	16.38	0.000016
1 ft ³	1728	1	28.316	28316	0.0283
1 liter	61.02	0.035	1	1000	0.001
1 cm ³	0.061	0.00003	0.001	1	0.000001
1 m ³	61023	35.33	1000	1000000	1

