



Technology for Vacuum Systems

Instructions for use



GKF 1000i

Cold trap

Content

Safety information!	3
General information.....	3
Intended use.....	3
Setting up and installing the cold trap GKF 1000i	3
Ambient conditions	3
Operating conditions of cold trap GKF 1000i	4
Safety during operation	4
Technical data	5
Wetted parts	5
Device parts	6
Use and operation	7
Installing in a vacuum system	7
During operation.....	7
Maintenance and cleaning	8
Accessories / Spare parts	8

After sales service:

Contact your local dealer or call +49 9342 808-5500.



➔ DANGER indicates a hazardous situation which, if not avoided, will result in death or serious injury.



⚠ WARNING indicates a hazardous situation which, if not avoided, could result in death or serious injury.



• CAUTION indicates a hazardous situation which, if not avoided, could result in minor or moderate injury.



NOTICE is used to address practices not related to personal injury.

Trademark index:

VACUU•LAN® (US-Reg.No 3,704,401), VACUU•BUS®, VACUU•CONTROL™, chemistry-HYBRID™, Peltronic®, TURBO•MODE™, VARIO®, VARIO-SP™, VACUUBRAND® (US-Reg.No 3,733,388) and also the shown company logos are trademarks of VACUUBRAND GMBH + CO KG in Germany and/or other countries.

Safety information!

General information

WARNING

- ☞ Read this manual carefully before installing or operating the equipment. Observe the instructions contained in this manual. Comply with technical data and notes on use and operation.
- ☞ Do not use any damaged equipment.

CAUTION

- Prior to every use: Check the cold trap for damage. The glass surfaces must be free from damage, notches, cracks or scrapers.

NOTICE

Remove the product from its packing-box. If the equipment is damaged, notify the supplier and the carrier in writing within three days; state the item number of the product together with the order number and the supplier's invoice number. Retain all packing material for inspection. In case, mount enclosed components.

Intended use

WARNING

- ☞ Comply with notes on correct vacuum connections, see section "Use and operation".

NOTICE

Use the cold trap for the intended use only, i.e., for the condensation of vapours in vacuum installations.

Suitable coolants: Liquid nitrogen (LN₂) or acetone-dry ice (CO₂) mixtures.

Setting up and installing the cold trap GKF 1000i

WARNING

- ☞ Prevent any part of the human body from coming into contact with vacuum or with cryogenic coolant.

CAUTION

- Assemble the cold trap to a base plate or or fixate at a stand mounting. Provide a firm, level platform. Check that the system to be evacuated as well as the hose and ground joint connections are mechanically stable and that all fittings are secure.
- **Note:** Flexible elements will shrink when evacuated.
- Prevent mechanical stress at the connection due to tensile force or vibrations.
- Connect hoses gas tight towards the vacuum installation and towards the inlet of the vacuum pump.
- Maximum operating pressure: **1.1 bar absolute**.

NOTICE

Comply with all applicable and relevant safety requirements (regulations and guidelines). Implement the required actions and adopt suitable safety measures.

Ambient conditions

WARNING

- ☞ Pay attention to the **permissible maximum ambient temperatures** between **+10°C and +40°C** (see "Technical data").

Operating conditions of cold trap GKF 1000i



- ➔ The cold trap GKF 1000i is **not suitable** to condensate
 - **unstable substances**,
 - **self inflammable** substances,
 - substances which are inflammable without air and
 - **explosive substances**.

Safety during operation



- ➔ Adopt suitable measures to prevent the release of dangerous, toxic, explosive, corrosive, noxious or polluting fluids when draining condensate.
- ➔ Adopt suitable measures to prevent the formation of explosive or flammable mixtures. Oxygen may condensate at the temperature of liquid nitrogen, use inert gas for venting if necessary.
- ➔ A great amount of gas can be absorbed on cold surfaces. The gases may expand abruptly in case of warming. This may lead to inadmissible overpressure in the system. Risk of bursting!



- ☞ Check coolant level in the cold trap during operation at appropriate intervals. Coolant may overflow unexpectedly, e.g., in case of large amounts of gas.
- ☞ Comply with applicable regulations when disposing of condensates. Take into consideration that the condensate may be polluted. Take adequate precautions to protect yourself and other people from the effects of dangerous substances (inhaling or skin contact). Wear appropriate safety-clothing and safety glasses.
- ☞ Use only **genuine spare parts and accessories**. Otherwise safety and performance of the equipment might be reduced.
- ☞ Do not use damaged components.



- Perform a visual check of the cold trap prior to every use. Check the cold trap for damage: There must be no damage, notches, cracks or scrapers on the glass surface.
- Comply with all applicable safety measures and requirements when using cryogenic coolants. Use only transport receptacles intended for coolants. Wear safety glasses and protective gloves.
- Do not clamp the covers of coolant receptacles. Ensure pressure compensation between coolant receptacle and atmosphere at any time.



Check condensate level regularly and drain condensate in time (condensate drain valve).

To the best of our knowledge the cold trap GKF 1000i is in compliance with the requirements of the applicable standards and directives.

Technical data

Cold trap	GKF 1000i
Connection to vacuum pump	glass tubing, outer diameter 22 mm
Connection to recipient	female ground joint NS 29/32
Coolant	liquid nitrogen (LN ₂) or acetone-dry ice (CO ₂) mixture
Coolant capacity approx.	1 l
Lifetime of coolant (for N ₂ , p < 10 ⁻³ mbar, ambient temperature 20°C) approx.	14 h
Condensate capacity approx.	0.25 l
Maximum permissible range of operation pressure	from vacuum up to 1.1 bar absolute
Permissible ambient temperature range	+10°C to +40°C
Dimensions (diameter x height)	148 mm x 580 mm
Weight approx.	4.1 kg

Wetted parts

Components	Wetted materials
Cold trap	Borosilicate glass
Valve (condensate drain)	PTFE
O-ring (condensate drain)	FPM

Device parts

Position	Component
1	connection of recipient (female ground joint NS 29/23)
2	connection of vacuum pump (glass tubing, outer diameter 22 mm)
3	sheet metal shield (protection against disintegration in case of implosion)
4	cover
5	condensate drain valve
6	sight strip for coolant and condensate

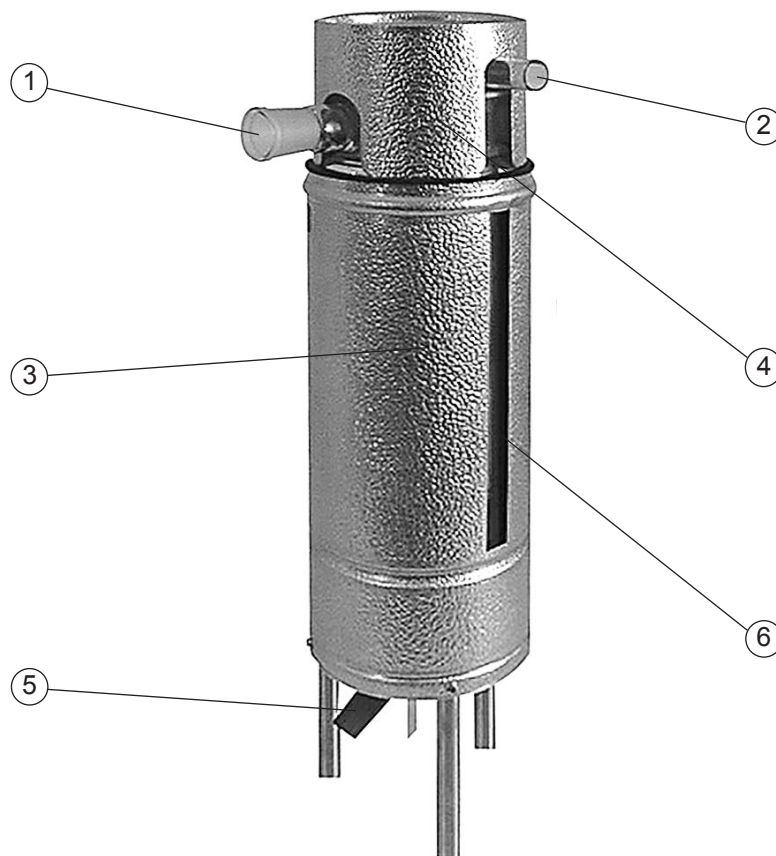
GKF 1000i

Use and operation

Installing in a vacuum system



- Remove the transportation safety device (foam insert) in the cove of the cold trap.
- Grease the ground joints prior to use with vacuum grease.
- Assemble the cold trap to a base plate or fixate at a stand mounting.
- Connect the cold trap to the vacuum pump and the recipient.
- ☞ Prevent mechanical stress at the connection due to tensile force or vibrations.
- Close the condensate drain valve.
- ☞ Due to the O-ring, the valve seals already at small contact pressure of the valve face.

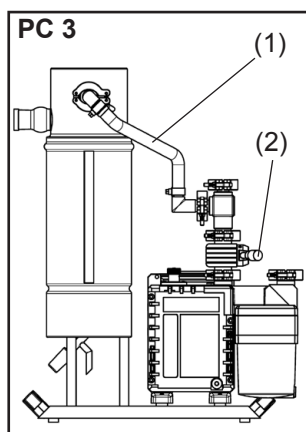

PC 3 with GKF 1000i:

- Assemble the separately packed vacuum hose (1) between the cold trap (connection of vacuum pump) and the inlet of the rotary vane pump / Chemistry HYBRID pump RC 6 (small flange connections NW 16, see figure).

During operation



- Remove cover and plastic insert of the cool trap. Fill coolant into the coolant chamber.
- Switch on the vacuum pump immediately after filling in the coolant. Open valve (2) between vacuum pump and cold trap (PC 3). Do not pump condensable vapours or gases until the vacuum pump has reached its operating temperature.
- ☞ The coolant consumption is increased if the condensate chamber is not evacuated.
- ☞ The lifetime of the coolant may be restricted due to icing in case of high operating pressures.
- Vent the cold trap for de-icing or draining of condensate.

WARNING

- ☞ Check coolant level at appropriate intervals.

NOTICE

Check the level of condensate at appropriate intervals and if necessary drain condensate via the condensate drain valve. Vent the system prior to opening the drain valve!

- Wait until the condensate has liquidised, if necessary.

CAUTION

- Ensure that condensate drain tubing and collecting equipment are chemically resistant against the condensate.



Remove the cold trap from the vacuum installation to drain the coolant if necessary.

Maintenance and cleaning

- The cold trap is maintenance-free.
- Clean the metal cover of the cold trap using water only.
- Clean the coolant chamber and the condensate chamber using water or solvent. Ensure compatibility of the wetted parts.



☞ Comply with applicable regulations when disposing of solvents.

Accessories / Spare parts

Special coupling	667057
(stainless steel; coupling to connect a glass tube with outer diameter 22 mm to a small flange NW 16)	
Special coupling	667055
(stainless steel; coupling to connect a glass tube with outer diameter 22 mm to a small flange NW 25)	
Coupling	662705
(stainless steel; to connect a ground joint NS 29/32 to a small flange NW 25)	
O-ring 3.5 x 1.5, FPM (at the condensate drain valve)	3120560