

Translation of the Original Operating Instructions

Turbomolecular Drag Pumps With Electronic Drive Units TC 100



TMH 071 Y P
TMU 071 Y P

Index

	Page	Page
1. Safety Instructions.....	3	
1.1. For Your Orientation	3	
1.2. Pictogram Definitions	3	
2. Understanding The Pumps TMH 071 Y P/TMU 071 Y P	4	
2.1. Main Features.....	4	
Proper Use.....	5	
Improper Use.....	5	
2.2. Differences Between The Pump Types.....	5	
2.3. Scope of Delivery.....	5	
3. Installation.....	6	
3.1. Preparations For Installation	6	
3.2. Connecting The High Vacuum Side	6	
3.3. Connecting The Fore Vacuum Side	9	
3.4. Connecting The Cooling Unit.....	10	
3.5. Connecting The Venting Valve.....	10	
3.6. Connecting The Casing Heating Unit.....	10	
3.7. Connecting The Sealing Gas Valve	11	
3.8. Connecting The Electronic Drive Unit TC 100	12	
3.9. Installing The Power Unit.....	12	
3.10. Installing The Operating And Display Control Unit DCU 001, DCU 100 or HPU 001	12	
3.11. Remote Control Unit.....	13	
3.12. Connecting The Serial Interface RS 485	14	
Connection.....	14	
Connecting The RS 485	14	
3.13. Connections Diagram	15	
4. Operations.....	16	
4.1. Before Switching ON	16	
4.2. Switching ON.....	16	
4.3. Operations Via The Remote Control Unit	16	
Local/Remote.....	16	
Accessory Inputs	16	
Pumping Station	16	
Standby/Reset	16	
Switch Outputs.....	17	
Accessory Outputs	17	
Analog Output.....	17	
4.4. Gas Type Dependent Operations	17	
4.5. Switching OFF And Venting.....	18	
4.6. Operations With The DCU 001, DCU 100 or HPU 001	18	
4.7. Shutting Down For Longer Periods	18	
5. Monitoring Operations.....	19	
5.1. Operations Display Via LED	19	
5.2. Turbopump Temperature Management	19	
6. What To Do In Case Of Breakdowns ?	20	
7. Maintenance / Replacement.....	21	
7.1. Replacing The Electronic Drive Unit TC 100 ...	21	
7.2. Replacing The Lubricant Reservoir	22	
8. Service	23	
9. Technical Data	24	
9.1. Dimensions Diagram	25	
10. Spare Parts	26	
11. Accessories.....	27	
Declaration of Contamination	28	
Manufacturer's Declaration... (last page)		

Please note: Current operating instructions are available via www.pfeiffer-vacuum.net

For information about certifications, if applicable, please see the signet on the pump or:

 www.tuvdotcom.com

 TUVdotCOM-ID 0000021320

1. Safety Instructions

- ☞ Read and follow all instructions in this manual.
- ☞ Inform yourself regarding:
 - Hazards which can be caused by the pump;
 - Hazards which can be caused by your system.
 - Hazards which can be caused by the media being pumped.
- ☞ Avoid exposing any part of the body to vacuum.
- ☞ Observe the safety and accident prevention regulations.
- ☞ Regularly check that all accident prevention measures are being complied with.
- ☞ Do not operate the turbopump with open high vacuum flange.
- ☞ Do not carry out any unauthorised conversions or alterations to the turbopump with TC 100.
- ☞ When returning the turbopump observe the shipping instructions.
- ☞ The turbopump must be anchored in accordance with the installation instructions.
- ☞ Do not disconnect the plug between the TC 100 and accessory components during operations.
- ☞ Disconnect the voltage supply for the TC 100 before opening the turbopump.
- ☞ When working on the turbopump, the high vacuum flange should only be opened once the rotor is at rest.
- ☞ When using sealing gas, the pressure in the hose connection should be limited to 2 bar via the overpressure valve.
- ☞ If a heater is in use temperatures of up to 120 °C can be present in the area of the high vacuum flange. Take care to avoid burns!
- ☞ During operations, temperatures of up to 65 °C can arise in the lower part of the turbopump. Take care to avoid burns!
- ☞ Keep leads and cables well away from hot surfaces (> 70 °C).
- ☞ Operate the turbopump with TC 100 only in conjunction with the relevant power unit (accessory).
- ☞ The unit has been accredited protection class IP 30. When the unit is operated in environments which require other protection classes, the necessary measures must be taken. Protection class IP54 is afforded for the Electronic Drive Unit TC 100 by using a suitable 15 pole D-Sub plug (accessory).
- ☞ The mains connection must be subject to a safe connection to the PE (protection class 1).
- ☞ The housing screws do not loosen, pull tight, remove or replace, since otherwise the guarantee for the security of the turbopump expires.

Modifications reserved.

1.1. For Your Orientation

Instruction in the text

→ Working instruction: here, you have to do something.

Abbreviations used

DCU = Display and operating unit

HPU = Display and operating unit

TC = Electronic drive unit, turbopump

TMP = Turbomolecular pump

TPS = Power unit

TCS = Connection Box

Symbols used

The following symbols are used throughout in all illustrations.

⊕ High vacuum flange

⊖ Fore vacuum flange

⊙ Venting connection

⊗ Cooling water connection

⊕ Air cooling

⚡ Electric connection

⊕ Sealing gas connection

Position numbers

The same pump and accessory parts have the same position numbers in all illustrations.

1.2. Pictogram Definitions



Warning!

Danger of burns from touching hot parts.



Warning!

Danger of personal injury.



Caution!

Danger of damage to the pump or to the system.



Warning!

Danger of injury from rotating parts.



Please note!

Attention to particularly important information on the product, handling the product or to a particular part of the documentation.

2. Understanding The Pumps

2.1. Main Features

Turbopumps TMH 071 YP/TMU 071 YP with the TC 100 form a complete unit. Voltage is supplied by the power unit (see "Accessories").



Ambient conditions

The turbomolecular pump needs to be installed in compliance with the following ambient conditions:

Installation location:	protected against the weather (rooms within buildings)
Temperature:	+5 °C to +40 °C
Relative humidity of the air:	max. 80 % at $T \leq 31$ °C up to max. 50% at $T \leq 40$ °C
Air pressure:	77 kPa - 106 kPa
Installation altitude:	2000 m max.
Pollution degree:	2
Overvoltage category:	II
Connection voltage:	24 VDC $\pm 5\%$

Cooling

- Enhanced convection cooling with cooling unit (accessory),
- air cooling (accessory) or
- water cooling (accessory).

Integrated protective measures against excess temperatures:

The Electronic Drive Unit TC 100 reduces the rotor rotation speed.

Bearings

- High vacuum side: Wear free permanent magnetic bearing.
- Fore vacuum side: Oil circulatory lubricated ball bearing with ceramic balls.

Proper Use

- The Turbomolecular Pumps TMH 071 YP/TMU 071 YP may only be used for the purpose of generating vacuum.
- The turbopumps may only be used to pump those media against which they are chemically resistant. For other media the operator is required to qualify the pumps for the processes involved.
- If the process produces dust, the maintenance intervals must be specified accordingly and sealing gas must be used.
- If the pump to be operated with more than 50% of the permissible gas load, sealing gas must be used.
- The turbopump must be connected to a backing pump in accordance with Section 3.3.
- Only Pfeiffer Vacuum power units may be used to operate. The use of other power units requires the prior agreement of the manufacturer and equalization with the valid specification.
- The pumps with TC 100 may only be operated providing the ambient conditions in compliance with Protection Type IP 30 are observed.

Improper Use

The following is regarded, inter alia, as improper:

- The pumping of explosive or corrosive gases.
- Operating the pumps in areas where there is a danger of explosion.
- Operating the pumps in areas where there is a danger of radioactivity.
- The pumping of gases and vapours which attack the materials of the pumps.
- The pumping of corrosive gases without sealing gas.
- The pumping of condensating vapours.
- Operations involving impermissibly high levels of gas loads.
- Operations with improper gas modes.
- Operations involving too high levels of heat radiation power (see Section 9. "Technical Data").
- Operating the pump in environments which require a protection class superior to IP 30.
- Installation of the pumps in systems where the turbomolecular pumps are subjected to impact-like stress and vibrations or the effect of periodically occurring forces.
- Operations without the use of cooling equipment.
- The use of other power units or accessories which are not named in this manual or which have not been agreed by the manufacturer.

Improper use will cause all claims for liability and guarantees to be forfeited.

2.2. Differences Between The Pump Types

Feature	TMH 071 Y P	TMU 071 Y P
High vacuum flange	ISO-KF/ ISO-K	CF-F
High vacuum seal	Elastomer	Metal
Attainable final pressure	$< 1 \cdot 10^{-7}$ mbar (without baking-out)	$< 5 \cdot 10^{-10}$ mbar (with baking-out)

Abbreviations on the type of the pump

Suffix "Y": Turbopump for fitting in all positions.

Suffix "P": Purge gas connection for the prevention of the ingress of aggressive gases into the motor and bearing arena.

2.3. Scope Of Delivery

Turbomolekular pump with:

- Electronic Drive Unit TC 100,
- protecting cover for high vacuum flange,
- protecting cover for fore vacuum flange,
- only DN 63 ISO-K: 2 bracket screws.

3. Installation

3.1. Preparations For Installation



Do not carry out any unauthorised conversions or alterations to the turbopump.
The operator must ensure that the electronic is integrated into an emergency safety circuit.
The supply voltage of the electronic must be interrupted when releasing the emergency safety condition.
For special requirements please contact Pfeiffer Vacuum.



In case the rotor blocks suddenly, torque levels up to **820 Nm** can occur which need to be absorbed by the system and the high vacuum flange.

- The maximum permissible rotor temperature of the pump is 80 °C. If the vacuum chamber or parts in the vacuum chamber are heated, the values stated in the technical data relating to the level of heat which may be radiated into the pump must not be exceeded. If necessary, suitable shielding must be fitted in the vacuum chamber before the turbopump (constructional suggestions available on request).
- The temperature of the high vacuum flange must not exceed 120 °C.
- Only remove the blank flange from the high and fore vacuum side immediately before connection.
- On Turbopumps TMH/TMU 071 YP the lubricant reservoir is already fitted and filled.
- Where magnetic fields of > 3 mT are involved suitable shielding must be provided (available on request).
- Either enhanced convection, air or water cooling is necessary for operating the pump (please see "Accessories").
- If the pump is baked out, the heating sleeve and the body of the pump must be insulated to prevent burns from accidental contact.
- Floor mounting of the turbomolecular pump is only admissible after consulting the manufacturer.
- The option to connect two of accessory components is provided on the Connection Box TCS 010 (please see Section 11. Accessories) which is secured into the Electronic Drive Unit TC 100.

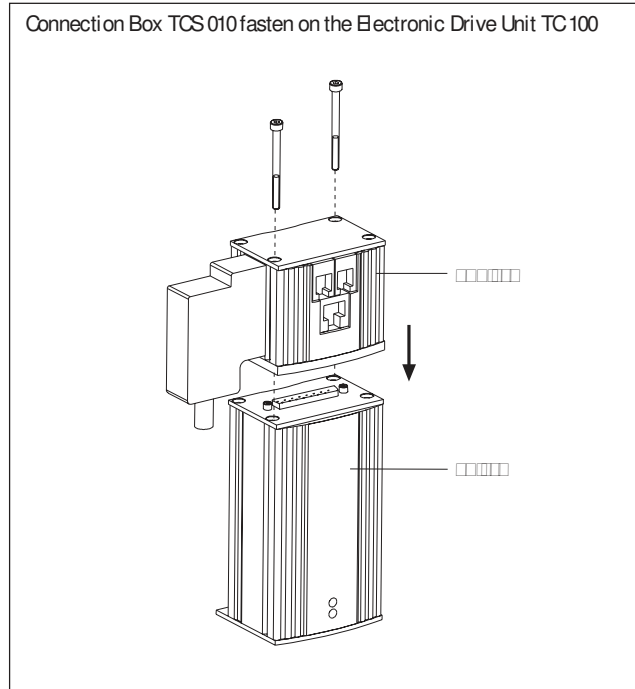

The person responsible for commissioning must ensure that the installation is carried out in accordance with the legal regulations and the pertinent industrial standards.

3.2. Connecting The High Vacuum Side



The utmost cleanliness must be observed when fitting all high vacuum parts. Unclean components prolong the pumping time.
All installations units for the flange must be with installation grease-free, dust free and drying.

Use a Pfeiffer Vacuum splinter shield or protective screen
The use of a Pfeiffer Vacuum splinter shield or protective screen in the high vacuum flange protects the turbopump against foreign bodies coming from the vacuum chamber but does reduce the volume flow rate as followed:

	Reduced volume flow rate in %		
	N ₂	He	H ₂
Splinter shield DN 63	13	5	3
Protective screen DN 63	3	1	1
Splinter shield DN 40	26	13	8

Connecting via a Pfeiffer Vacuum vibration compensator
The high vacuum side can be flanged onto the vacuum chamber either directly or via a Pfeiffer Vacuum vibration compensator (see Section 11. Accessories).

When using a Pfeiffer vacuum vibration compensator, suitable securing needs to be introduced capable of absorbing the energy of the rotor should it suddenly block, since the vibration compensator itself alone cannot absorb the occurring forces. Please consult the manufacturer.



The maximum permissible temperature at the vibration compensator is 100 °C.

Installing the high vacuum flange

- In case the rotor blocks suddenly, torque levels up to **820 Nm** can occur which need to be absorbed by the system and the high vacuum flange.
- For installing the turbomolecular pumps to the high vacuum flange, the components listed in the following **must** be used exclusively. Otherwise the turbomolecular pump may twist or tear off. The clamps, bolts, nuts and centering rings are special designs from Pfeiffer Vacuum
- The minimum strength of 170 N/mm² of the flange material needs to be observed.

Installation is done as follows:

ISO-K flange with ISO-K flange

The components for installation are enclosed in the appropriate set of mounting material (see sec. 11. Accessories).

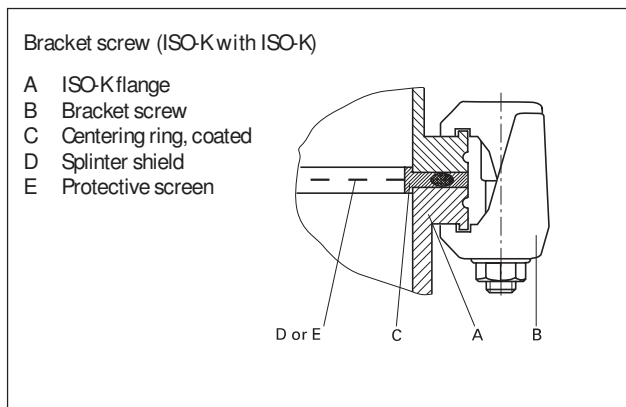

- See that the sealing surface is not damaged.
- Flange the turbopump according to the drawing and the component parts in your set of mounting material.
Use 4 bracket screws.
- Tighten the bracket screws crosswise in three steps.
Tightening torque: 25 ±2 Nm

ISO-K flange with ISO-F flange



If the pumps are secured with an ISO-K flange on a vacuum chamber with an ISO-F flange it can come to twisting at the flange in case the rotor blocks suddenly.

The components for installation are enclosed in the appropriate set of mounting material (see sec. 11. Accessories).

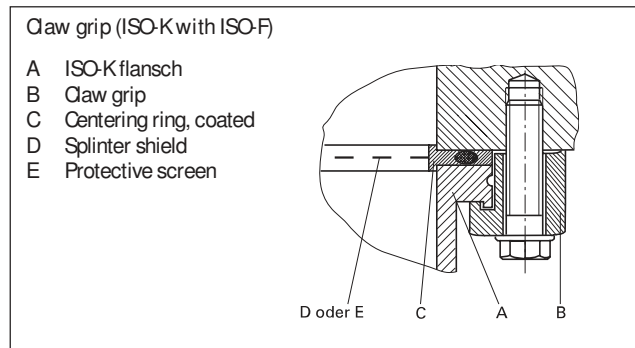

- See that the sealing surface is not damaged.
- Flange the turbopump according to the drawing and the component parts in your set of mounting material.
Use 4 claw grips.
- Tighten the claw grips crosswise in three steps.
Tightening torque: 16 ±1 Nm

ISO-KF flange with ISO-KF flange

For installing the following components are available.



If the pumps are secured with this attachment it can come to twisting the flange in case the rotor blocks suddenly.

Connection nominal diameter	Designation	Order number
DN 40 ISO-KF	Clamping ring for metal seal	PF 105 040 -T
	Centering ring	PF 110 140 -T
	Splitter shield	PM 600 375 -X

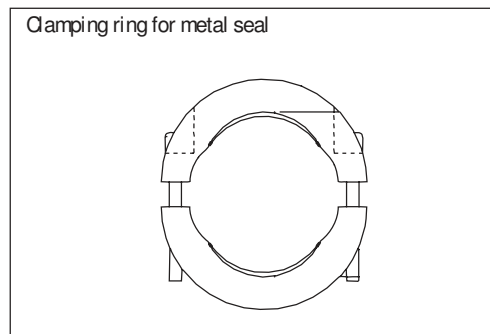

- The screws on the clamping ring need to be tightened with a tightening torque of 3.7 Nm.

CF-F flange

Applications for installing an CF-F to an CF-F flange are “Stud screw with blind hole” and “Hexagon screw and clearance hole”. The following items are needed: the particular set of mounting material and a copper seal. Using a splinter shield or protective screen is optional.



Don't touch the copper seal with bare hands, this may affect the sealings efficiency. See that the sealing lip is not damaged.

Stud screw with blind hole

- If used: Insert the splinter shield and protective screen in the high vacuum flange with the clamping lugs downward (towards the pump).
- Bring the seal centric into the correct position.
- Connect the flanges via **8** pieces of stud screws (M8) with washers and nuts. The stud screws need to be tightened revolving with a tightening torque of 22 ± 2 Nm. Control the torque afterwards, because of the sealing material's flowing a retightening of the screws may be required.

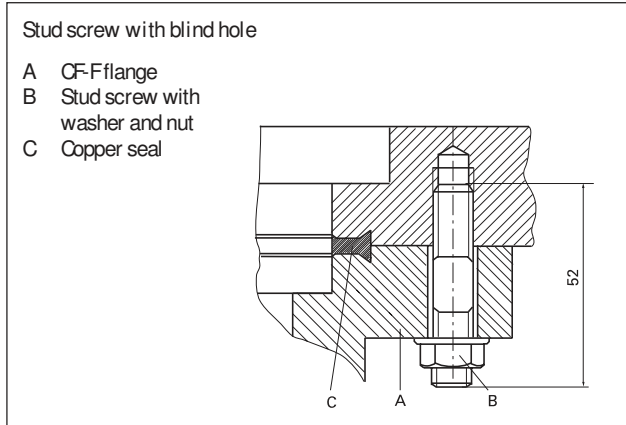

Hexagon screw and clearance hole

- If used: Insert the splinter shield and protective screen in the high vacuum flange with the clamping lugs downward (towards the pump).
- Bring the seal centric into the correct position.
- Connect the flanges via **8** pieces of hexagon screws (M8) with washers and nuts. The hexagon screws need to be tightened revolving with a tightening torque of 22 ± 2 Nm. Control the torque afterwards, because of the sealing material's flowing a retightening of the screws may be required.

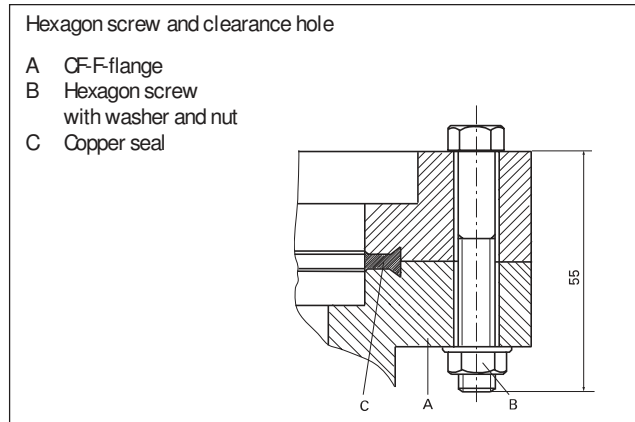

The components for installing to an CF-F flange are to be ordered under the following numbers:

Connection nominal-diameter	Designation	Order-number
DN 63 CF-F	Hexagon screw M8 with washer and nut (25 pieces ¹⁾)	PF 505 002 -T
	Stud screw M8 with washer and nut (18 pieces ¹⁾)	PF 507 002 -T
	Copper seal (10 pieces ¹⁾) or copper seal silvered (10 pieces ¹⁾)	PF 501 406 -T PF 501 506 -T
	Splinter shield	PM 016 312
	Protective screen	PM 016 333

1) supplied pieces

Directly flanging the pump

The high vacuum flange of the turbopumps in "Y" version can be fitted in all positions.

With horizontal pump installation and oil-sealed backing pumps (e.g. rotary vane pumps) the fore-vacuum flange of the turbopump should be aligned vertically downwards (maximum deviation $\pm 20^\circ$), otherwise the turbopump could become dirty— due to backstreaming of rotary vane pump oil.

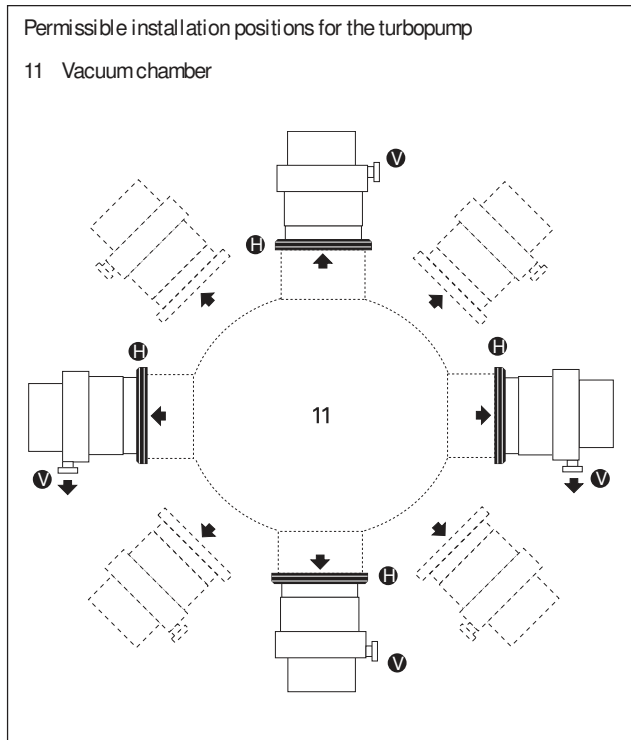

The maximum loading capacity of the high vacuum flange is 200 N (equivalent to 20 kg). Assymetric loading on the high vacuum flange must be avoided.

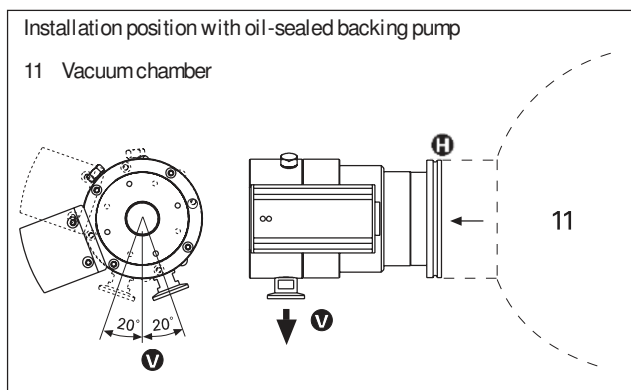

No forces from the piping system must be allowed to act on the pump where turbopumps are anchored. Suspend or support all pipes to the pump.

3.3. Connecting The Fore Vacuum Side

Backing pump: Vacuum pressure ≤ 10 mbar; with enhanced convection cooling $< 0,1$ mbar.
 Recommendation: Oil-Free Diaphragm Pump or Rotary Vane Vacuum Pumps from the Pfeiffer Vacuum range (note installation position, turbopump, see Section 3.2).

Connecting the backing pump

All connections of the fore vacuum line: with the usual small flange components or hose screw connections.



Be sure to conduct away the exhaust gases from the backing pump. Do not reduce the free cross section of the fore vacuum flange with following components.



The exhausted process gases and vapours can represent a health hazard and can also be environmentally damaging. Comply with all the gas manufacture's safety instructions.

- With rigid pipe connections: fit a bellows in the connecting line to reduce vibration.
- The fore vacuum pump is controlled via a relay box (accessory) and Connection Box TCS 010 (accessory) or in accordance with the connections diagram (please refer to Section 3.13).

Please refer to Operating Instructions PT 0030 BN for details on the relay box, backing pump and its installation and to Operating Instructions PT 0045 BN for details on the Connection Box TCS 010.

3.4. Connecting The Cooling Unit

Turbopumps TMH 071 YP/TMU 071 YP can optionally be provided with enhanced convection cooling, air cooling or water cooling. The turbopumps must be operated with air or water cooling where the fore vacuum pressure is increased (> 0.1 mbar) and/or operations with gas loads.

Air cooling may only be used where the ambient temperature is < 40 °C.

Use and installation

- For water cooling please refer to Operating Instructions PM 0546 BN.
- Permissible installation positions for the cooling unit where convection cooling is involved please see Section 9.1. "Dimensions Diagram".
- For air cooling please refer to Operating Instructions PM 0543 BN.

The electrical connection for the air cooling is effected via the control lead in the connection "Out1" of the TCS 010 or in accordance with the connections diagram (please see Section 3.13.).

3.5. Connecting The Venting Valve

The venting valve (accessory) provides automatic venting in the event of a power failure and switching off.

Fitting the venting valve

- Unscrew the venting screw from the venting connection of the turbopump.
- Screw in venting valve with seal (USIT ring) on hexagonal SW 14.

Electrical connection

- Plug control lead into the connection "Out2" of the TCS 010 or in accordance with the connections diagram (please see Section 3.13.).

For Details please refer to Operating Instructions for the Connection Box TCS 010, PT 0045 BN.

The venting mode of the venting valve is selected via DCU, HPU or PC (using the Serial Interface RS 485).



The maximum pressure at the venting valve is 1.5 bar absolute.

Please refer to Operating Instructions PM 0507 BN for details on Venting Valve TVF 005.

3.6. Connecting The Casing Heating Unit

In order to accelerate attainment of final pressures, turbopumps and vacuum chambers can be heated.

Baking out is only practical on pumps with stainless steel casings (TMU pumps). On account of their aluminium casings, the temperatures attainable on TMH pumps are not high enough.

Heating duration is dependent on the level of contamination and the required final pressure but should be at least four hours.



Where casing heating is involved the turbopump must be water cooled.



The temperature of the high vacuum flange must not exceed 120 °C (additional references please see Section 3.1.).



High temperatures are generated when turbopumps are heated.

There is a danger of injury from coming into contact with hot parts even after the casing heating has been switched off.

Heating sleeve and the pump casing should be thermally insulated during the installation.

During the heating phase be careful not to come into contact with the heating sleeve or the pump casing.

Casing heating control is effected via the TCS 010 (please refer to Operating Instructions PT 0045 BN for the TCS 010) or in accordance with the connections diagram (please see Section 3.13.).

For details regarding the casing heating and its installation please refer to Operating Instructions PM 0542 BN.

3.7. Connecting The Sealing Gas Valve

It is necessary to operate the turbopump using sealing gas which affords protection for the turbopump, particularly where corrosive and dusty processes are involved.

Even in non-corrosive processes, from 50% of the maximum gas load sealing gas should be used to ensure rotor cooling.

Connection is made via a sealing gas valve 66 (please see Section 11. Accessories).

Please refer to Operating Instructions PM 0229 BN for details on installing the sealing gas valve and adjusting the sealing gas flow.

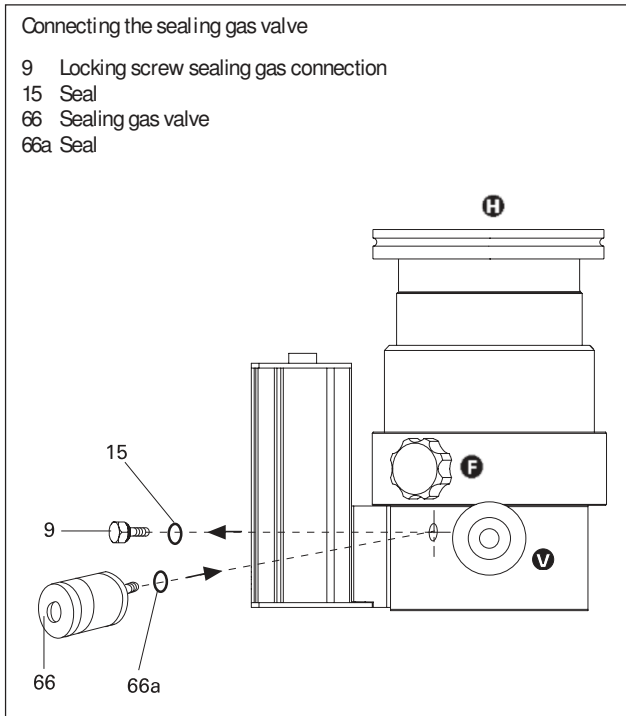

3.8. Connecting The Electronic Drive Unit TC 100



The turbopump and the Electronic Drive Unit TC 100 are connected and together form a single unit.
Connecting cable 8a has to be ordered separately (for cable with bridge please see "Accessories").

Connecting without DCU

- Connect plug X3 on connecting cable 8a with connection X3 on the TC 100 and secure with screw 8b.
- Connect plug X2 on connecting cable 8a with Power Unit TPS 100 ("Accessories") on connection X2 (please refer to Section 3.13. Connection Diagram).



Once operations voltage has been supplied, the Electronic Drive Unit TC 100 performs a self test on the supply voltage. The supply voltage for Turbomolecular Pumps TMH/TMU 071 Y P is 24 VDC $\pm 5\%$ in accordance.

(Connecting with DCU 001/DCU 100 please refer to Operating Instructions PM 0477 BN.)

3.9. Installing The Power Unit



Voltage may only be supplied with the Pfeiffer Vacuum power units (please see Section 11. Accessories).

The use of other power units requires the prior agreement of the manufacturer and equalization with the valid specification (power unit specifications available on request).

For further details regarding Power Unit TPS 100 please refer to Operating Instructions PM 0521 BN.



The mains connection must be freely accessible at all times.

3.10. Installing Operating And Display Control Unit DCU 001, DCU 100 or HPU 001

The Operating And Display Control Unit DCU 001, DCU 100 or HPU 001 can be connected via a TCS 010 (accessory) or a connecting cable TC 100/DCU - TPS (accessory). Please refer to the permissible operating instructions and Section 3.13. Connection Diagram.

Connecting the Electronic Drive Unit TC 100 with Power Unit TPS 100

- X1 Mains connection
- X2 Connection, power unit
- X3 Connection TC 100
- S1 ON/OFF switch
- 8 Electronic Drive Unit TC 100
- 8a Connecting cable, TC 100 – TPS 100
- 8b Screw
- 105 Power Unit TPS 100

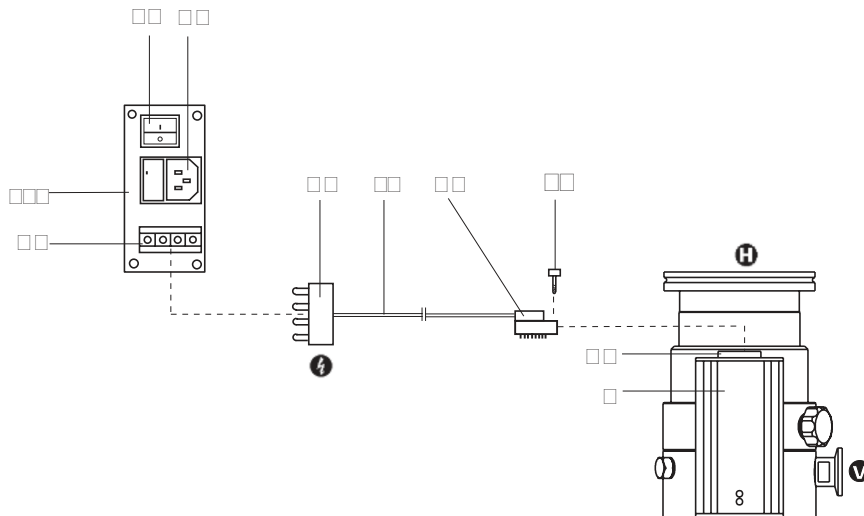

3.11. Remote Control Unit

Remote control options for various functions are available via connection plug X3 (Pin 2 – Pin 6) on the TC 100.

Shielded cable must be used. The shielding on the plug side of the Electronic Drive Unit TC 100 should be connected to the metal cap on the plug.

Inputs 2-6 are activated by supplying +24 VDC* from Pin 7 (active high) (please refer to Section 3.13. Connections Diagram).

Pin arrangement and functions of the 15 pole plug X3

(please refer to the following table)

Pin Arrangement And Functions Of Plug X3			
Pin nr.	Function		
1	Supply voltage	+24 VDC ±5% (I _{dauer} = 4,2 A; I _{max} = 4,6 A)	
	Inputs:	Open (low)	Closed (high)
2	Input remote/local ¹⁾	Remote: priority of Serial Interface RS 485	Local: priority of inputs (Pin 3-6)
3	Input accessory 1	not vent or heating OFF	vent or heating ON
4	Input accessory 2		
5	Input pumping station	Pumping station OFF	Pumping station ON: turbopump, backing pump and fan are switched ON
6	Input standby/reset	Standby OFF	Standby ON: Pump is accelerated to 66% of the nominal rotation speed. Reset: By supplying a pulse (T < 2 s) with an amplitude of 24 V a malfunction acknowledgement can be processed.
7	+ 24 VDC*		
	Outputs:	low (0 V)	high (24 V)
8	Switch output 1	Rotation speed switchpoint not attained	Rotation speed switchpoint attained: Output can be loaded with 24V/50mA
9	Switch output 2	Collective error message	trouble free operating: Output can be loaded with 24V/50mA
10	Accessory output 1	Accessory OFF	Accessory ON Works setting: fan
11	Accessory output 2	Accessory OFF	Accessory ON Works setting: automatic venting
12	Analog output	0 - 10 VDC = 0 - 100% *f _{end} (optional current/power)	
13	Serial Interface RS 485	D+ (DO/FI)	
14	Serial Interface RS 485	D- (DO/FI)	
15	Mass (ground)		

1) Only possible with activated parameter 028.
No function on delivery.

3.12. Connecting The Serial Interface RS 485

The connection of the Display And Operating Unit DCU 001, DCU 100 or HPU 001 is possible via the Connection Box TCS 010 or cable TPS - TC 100/DCU or HPU (please see Section 11. Accessories),

Please refer to the relevant Operating Instructions for the
 - TCS 010, PT 0045 BN,
 - DCU 001, PM 0477 BN or
 - HPU 001, PT 0101 BN.

Pin	Arrangement
1	not connected
2	+ 24 V output (loadable with 210 mA)
3	not connected
4	not connected
5	RS 485: D+ (DO/ FI)
6	Gnd — —
7	RS 485: D- (DO/ FI)
8	not connected

RS 485

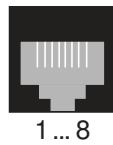

View from the TCS 010 plug side

An external computer can be connected directly to Serial Interface RS 485 via connection X3 (Pin 13, Pin 14).

Connection

Designation	Value
Pin 13: D+	
Pin 14: D-	
Serial interface type:	RS 485
Baud rate:	9600 Baud
Data file word length:	8 bit
Parity:	no parity
Start bits:	1
Stop bits:	1..2



It is possible to connect an RS 232 (e.g. PC) via a level converter (please see "Accessories").

Connecting The RS 485

Connection to a fixed bus system

- Connect all units with D+ (Pin 13/X3) and D- (Pin 14/X3) on the bus.
- The bus must be closed at both ends.

The connections must be made in accordance with the Serial Interface RS 485 specifications.

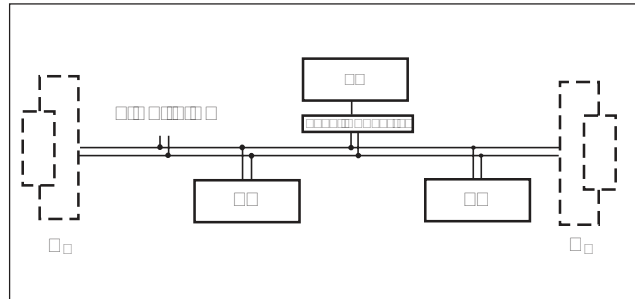

All units connected to the bus must have differing serial interface addresses (parameter 797).

The group address of the Electronic Drive Unit TC 100 is 950.



Only safety low voltage may be connected to the Serial Interface RS 485.

All switched on remote control functions have priority over the serial interface functions.



For further details regarding the operation of the Serial Interface RS 485 and its electrical data please refer to separate Operating Instructions PM 0488 BN.

Profibus DP Gateway TIC 250 is available (accessory) for connecting an Electronic Drive Unit TC 600 to a Profibus DP. Please refer to the respective Operating Instructions PM 0599 BN for detailed information on the operation of the TIC 250.

3.13. Connections Diagram

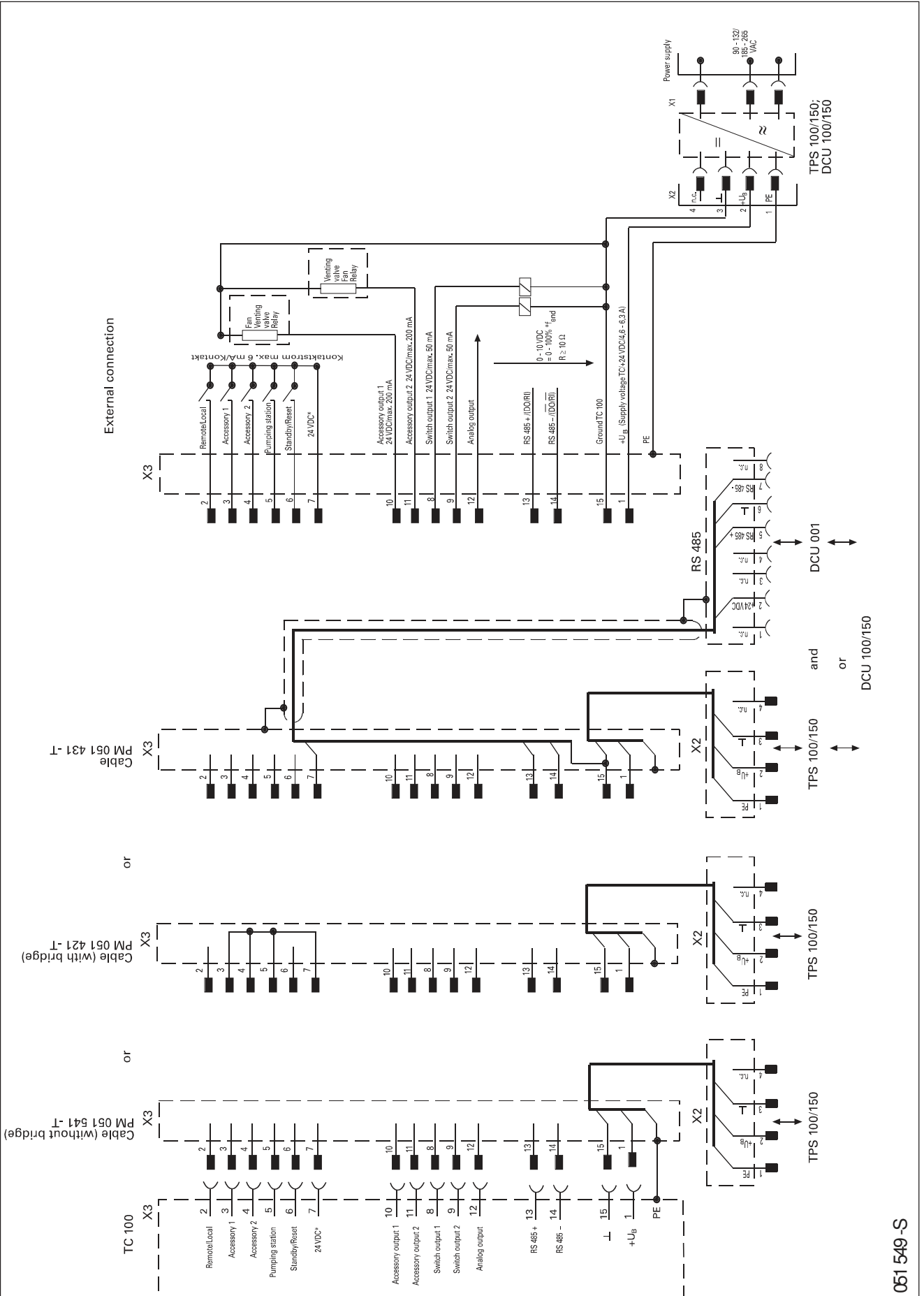

4. Operations

4.1. Before Switching ON

Sections 4.1. to 4.3. relate only to pump operations in the condition on delivery without display and operating unit.



Turbopump rotors turn at great speed. When the high vacuum flange is open there is a danger of personal injury and of damage to the pump resulting from the falling in of objects. Therefore, never operate the pump with an open high vacuum flange.

- With water cooling: open cooling water supply and check flow.
- Plug connecting cable 8a ("Accessory") into the TC 100 and connect with Power Unit TPS 100 (please see Section 3.7.).

Please note:

The following works settings are programmed:

- Start-up time: 8 min
- Rotation speed switchpoint 80%
- Automatic venting 50%

For further works settings please refer to the parameter overview in the operating instructions for the "Pumping Operations With the DCU", PM 0547 BN. These settings can only be altered via Serial Interface RS 485 (DCU or PC) (please refer to the respective operating instructions).



Take care when pumping hazardous gases. Take note of all safety recommendations of the gas manufacturer.

4.2. Switching ON

- Switch on the power unit with S1.
- After successful completion of the self-test on the TC 100 (duration approximately 10 seconds), the turbopump is – depending on the cable used (see sec. 11 Accessories) – ready to operate or starts operating.

The turbopump is operated via remote control (please refer to section 4.3.).

Rear Side, TPS 100

- S1 ON/OFF switch
- X1 Mains connection
- X2 Connection TC 100
- F1 Fuse
- F2 Fuse

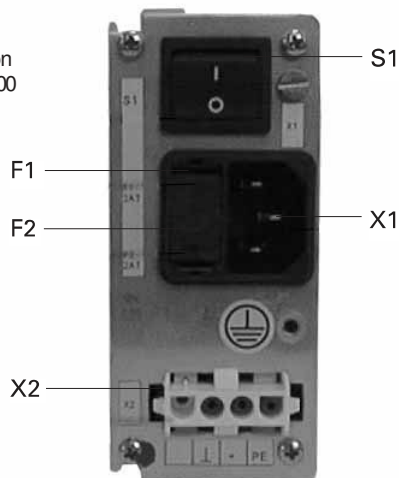

4.3. Operations Via The Remote Control Unit

(Please refer to the table in Section 3.11. and connection diagram in Section 3.13.)

Remote control options are possible via inputs

Pin 2 – Pin 6/X3 on the TC 100.

Shielded cable must be used. The shielding on the plug side of the Electronic Drive Unit TC 100 should be connected to the metal cap on the plug.

Inputs 2 - 6 are activated when they are connected to 24 VDC* on Pin 7/X3 (active high).

Local/Remote

(Pin 2/X3)

This input is used to determine whether the control should be effected via remote control inputs or Serial Interface RS 485 (only works in conjunction with parameter 028, please refer to Operating Instructions for Pumping Operations with the DCU, PM 0547 BN).

Accessory Inputs

(Pin 3/X3 and Pin 4/X3)

The components backing pump and air cooling (connectable to the accessory outputs) are switched automatically. The remote control inputs Pin 3 and Pin 4 are then ineffective. If the outputs are programmed to venting valve or the heating there is the option with the respective inputs venting release after the unit has been switched off and heating ON/OFF when the rotation speed switchpoint is exceeded.

Works setting: Out1 (Pin 3) = air cooling
Out2 (Pin 4) = venting valve

The accessory inputs and outputs can be assigned several functions via a DCU or the Serial Interface RS 485.

Pumping Station

(Pin 5/X3)

Connected pumping station components are started (backing pump, air cooling) and the turbopump is set in motion after successful completion of the self-test (duration approximately 10 seconds).

Standby/Reset

(Pin 6/X3)

With the use of "standby" the turbopump can be operated optionally at 66% of the nominal rotation speed (standby ON) or with the nominal rotation speed (standby OFF).

By supplying a pulse ($T < 2s$) with an amplitude of 24 V a

Switch Outputs

(Pin 8/X3 And Pin 9/X3)

The switch outputs 1 and 2 can be loaded with maximum 24V/50 mA per output. The following functions are assigned to the switch outputs:

- Switch output 1:** Active high after attainment of the rotation speed switchpoint. The switchpoint for the turbopump is set at 80% of the nominal rotation speed. It can be used, for example, for a signal "Pumpe betriebsbereit" ("pump ready to operate").
- Switch output 2:** Active low on collective error signal.

The connection of a relay is made between Pin 15 (mass) and the respective switch output Pin 8 or Pin 9 (please refer to Section 3.13. Connections Diagram).

Accessory Outputs

(10/X3 and Pin 11/X3)

The accessory outputs can be loaded with a maximum of 24 V/200 mA.

The works setting on the accessory outputs are:

- Accessory output 1:**
A connected air cooling system is started.

Accessory output 2

A connected venting valve is started if venting release has been transmitted via accessory input 2. Additional components can also be connected by respective selection via the DCU or the RS 485.

Analog Output

(Pin 12/X3)

A rotation speed proportional voltage (0 - 10 VDC correspond to 0 - 100%* f_{end}) can be tapped via the analog output (load ≥ 10 k Ω).

Additional functions (power, current) can be assigned to the analog output via a DCU or Serial Interface RS 485.

4.4. Gas Type Dependent Operations



Water cooling is required if the pumps are to be operated with gas load.

Where high level gas loads and rotation speeds are involved, the resulting friction subjects the rotor to the effect of great heat. To avoid over-heating, a power rotation speed characteristic line is implemented in the TC 100; this ensures that where maximum gas loads are involved, the pump will operate at any rotation speed without the danger of damage arising.

The maximum power is dependent on the type of gas. Two characteristic lines are available for any type of gas in order to fully exploit the power potential of the pump:

- "Gas-Mode 0" for gases with molecular mass ≥ 40 as, for example, Argon;
 - "Gas-Mode 1" for all lighter gases.
- Set the applicable gas mode on the TC 100 via the DCU 001, DCU 100 or HPU 001 (please refer to Operating Instructions "Pumping operations with The DCU" PM 0547 BN).
Works setting: Gas mode 0



Pumping gases with molecular mass ≥ 40 with the incorrect gas mode can cause damage to the pump. When pumping noble gases heavier than Argon it can come to the destruction of the pump. Please contact the manufacturer before using such gases.

For the vertex of the power characteristic line please refer to Section 9. Technical Data.

Maximum power is applied when the pump starts in order to limit the time required. Once the set rotation speed is attained, switching to the selected power characteristic line is automatic.

If the gas dependent maximum power is exceeded, the rotation speed is reduced until equilibrium between the permissible power and gas friction is attained. The power limitation serves to protect the pump against thermal overloading. In order to avoid rotation speed fluctuations it is recommended to set, in rotation speed setting mode, the equilibrium frequency or a somewhat lower frequency.

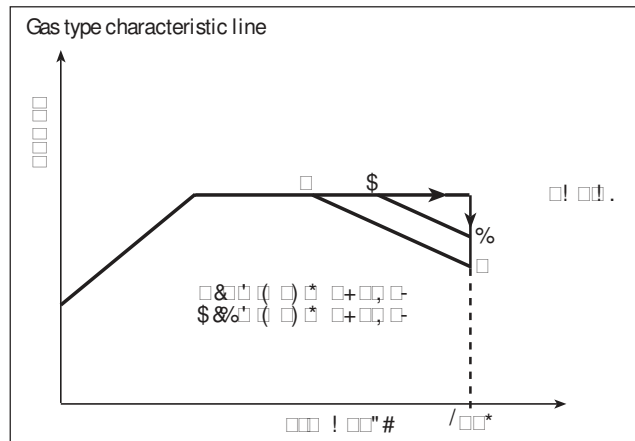

4.5. Switching OFF And Venting

Before coming to rest after switching off, the turbopump must be vented in order to prevent contamination.

- Close the fore vacuum.
- Switch off the turbopump with switch S1 on the power unit.
- Venting

There are three possibilities to vent turbopump:

- **Manual venting**
Open the venting screw (on delivery, screwed in) on the venting connection about one turn.
- **Venting with the Venting Valve TVF 005** (accessories)
Venting release via the remote control (please see Section 4.3.) or via the serial interface which is selectable via DCU or interface (see Operating Instructions, "Pumping Operations With The DCU", PM 0547 BN).
- **Venting in two stages** when the vacuum chamber should be vented as quickly as possible.
First stage: venting with a pressure increase rate of 15 mbar/s for 20 seconds.
Second stage: venting with an optionally large venting valve.

The valve cross-section for a venting rate of 15 mbar/s must be compatible with the size of the vacuum chamber. Where small vacuum chambers are involved, the Pfeiffer Vacuum Venting Valve TVF 005 can be used for first stage venting.

- Shut off water supply (if installed).

4.6. Operations With The DCU 001, DCU 100 or HPU 001

Operations with the DCU 001, DCU 100 or HPU 001 should be carried out in accordance with the relevant Operating Instructions:

- PM 0477 BN (DCU description),
- PM 0547 BN (operating the pump with the DCU),
- PT 0101 BN (Display And Operating Unit HPU 001).

4.7. Shutting Down For Longer Periods



If aggressive or hazardous gases are pumped there is a danger of personal injury resulting from coming into contact with process gases. Before removing a turbopump from the system, first:

- Vent the turbopump with a neutral gas or dry air.
- Ensure that there is no residual process gas in the system nor in the feeder lines.

If the turbopump is to be shut down for more than a year:

- Remove turbopump from the system.
- Change the lubricant reservoir (see Section 7.1.)



Lubricant TL 011 should not be used when there have been no operations for **3 years**.

- Close the high vacuum flange and evacuate the turbopump via the fore vacuum flange.
- Vent turbopump via the venting connection with nitrogen or dry air.
- Close fore vacuum and venting connection by blank flanging.
- Place the pump vertically on its rubber feet.
- The pump must be stored in buildings within a temperature range of -25 °C to +55 °C.
- In rooms with moist or aggressive atmospheres, the turbopump must be air-sealed in a plastic bag together with a bag of desiccant.



If the pump has been shut down for **3 years**, the bearing must be changed (please contact Pfeiffer Vacuum Service).

5. Monitoring Operations

5.1. Operations Display Via LED

Certain operations modes of the turbopump and the TC100 can be ascertained via the two integrated LEDs located on the front panel of the Electronic Drive Unit TC100.

The following operations modes are displayed:

LED		Cause
green	red	
Glow		<ul style="list-style-type: none"> – Power supply OK – Function "pumping station ON" carried out
Flashes		<ul style="list-style-type: none"> – Power supply OK – Pumping station OFF
Blinks		<ul style="list-style-type: none"> – Mains power supply failure
	Glow	<ul style="list-style-type: none"> – Collective malfunction (for example, run-up time error, over-temperature, turbopump or TC100) – Switching output 2 active (low)
	Blinks	<ul style="list-style-type: none"> – Warning (e.g. supply voltage short circuit to earth, mains power failure)

5.2. Turbopump Temperature Management

Where impermissible motor temperatures are involved or the temperature of the casing is too high, the motor current is reduced.

This can lead to dipping below the set rotation speed switch-point and results in the turbomolecular pump being switched off.

LED on the TC100 glows red: Collective malfunction.



Differentiated malfunction and warning signals are only possible with the use of the DCU.

6. What To Do In Case Of Breakdowns?

Problem	Possible Causes	Remedy
Pump doesn't start; None of the integrated LEDs glow on the TC 100	<ul style="list-style-type: none"> • Power supply interrupted • Incorrect operations voltage supplied • Pins 3,4,5 and 7 on the Plug X3 not connected • No supply of operations voltage • Defect TC 100 • Reduction in the voltage in the cable 	<ul style="list-style-type: none"> • Check fuse in the power supply • Check plug contacts on the mains power supply • Check power supply feeder line • Check voltage on the power supply (24 VDC) at connection X2 • Supply correct operations voltage • Connect pins 3,4,5 and 7 on the plug X3 • Check plug contacts on the power supply • Inform Pfeiffer Vacuum Service of need for repair • Use suitable cable
Pump doesn't attain nominal rotation speed within the set run-up time Pump cuts out during operations	<ul style="list-style-type: none"> • Fore vacuum pressure too high • Leak or too much gas • Rotor sluggish caused by defective bearing • TC run-up time too short • Thermal overloading caused by <ul style="list-style-type: none"> – Water flow insufficient – Insufficient air supply – Fore vacuum pressure too high – Ambient temperature too high 	<ul style="list-style-type: none"> • Check backing pump function • Check seals • Seek leak and repair • Reduce supply of process gas • Check bearing (noises?): Inform Pfeiffer Vacuum Service • Set longer start-up time with the DCU, HPU or PC • Ensure free flow • Ensure adequate air supply • Reduce fore vacuum pressure • Reduce ambient temperature
Pump doesn't attain final pressure	<ul style="list-style-type: none"> • Pump dirty • Leak in vacuum chamber, lines or pump 	<ul style="list-style-type: none"> • Bake out pump • If seriously contaminated: Request Pfeiffer Vacuum Service to clean • Seek leak starting with vacuum chamber • Repair leak
Unusual operating noises	<ul style="list-style-type: none"> • Bearing damaged • Rotor damaged • Splinter shield (if fitted) not seated firmly 	<ul style="list-style-type: none"> • Inform Pfeiffer Vacuum Service of need for repair • Inform Pfeiffer Vacuum Service of need for repair • Check seat of splinter shield (see Section 3.2)
Red LED on the TC 100 glows	<ul style="list-style-type: none"> • Collective malfunction 	<ul style="list-style-type: none"> • Reset via mains OFF/ON when the TMP is at standstill or remote pin 6 • Different malfunction display with the DCU/HPU possible¹⁾
Red LED on the TC 100 flashes	<ul style="list-style-type: none"> • Warning through: <ul style="list-style-type: none"> – Mains power failure – Supply voltage short circuit to earth • Wrong setting for set rotation speed (Parameter 777) 	<ul style="list-style-type: none"> • Different warning message with the DCU/HPU possible¹⁾ • Check power supply voltage • Check power supply mains connection • Check power supply voltage for short circuit earth • Enter 1500 Hz for parameter 777 (see operating instruction PM 0547 BN "Pumping Operations With DCU"). If there is no DCU/HPU available contact Pfeiffer Vacuum Service.

1) Without a DCU/HPU inform Pfeiffer Vacuum Service to check the cause of trouble.

7. Maintenance / Replacement



No liability for personal injury nor material damage will be accepted for damages and operational interruptions which have been caused by improper maintenance; in addition, all guarantees become invalid.

The bearing should be changed every three years (request Pfeiffer Vacuum Service to change).

Where extreme operating conditions or unclean processes are involved, the replacement interval should be checked with your Pfeiffer Vacuum Service Center.

You can change the Electronic Drive Unit TC 100 and the lubricant reservoir yourself. Please contact your Pfeiffer Vacuum Service for all other maintenance and service work.



Apply no mechanical stress to the Electronic Drive Unit TC 100.

7.1. Replacing The Electronic Drive Unit TC 100



The turbopump and the TC 600 must only be disconnected from each other when the turbopump is completely at rest and the TC 600 has been disconnected from the power supply.

Remove the Electronic Drive Unit TC 100 from the turbopump as follows:

- Switch off the turbopump, vent to atmospheric pressure (see Section 4.5.) and allow to cool as necessary.
- If necessary, remove the turbopump from the system.
- Unscrew allen head screws 8c (2 pieces) from the electronic drive unit 8.

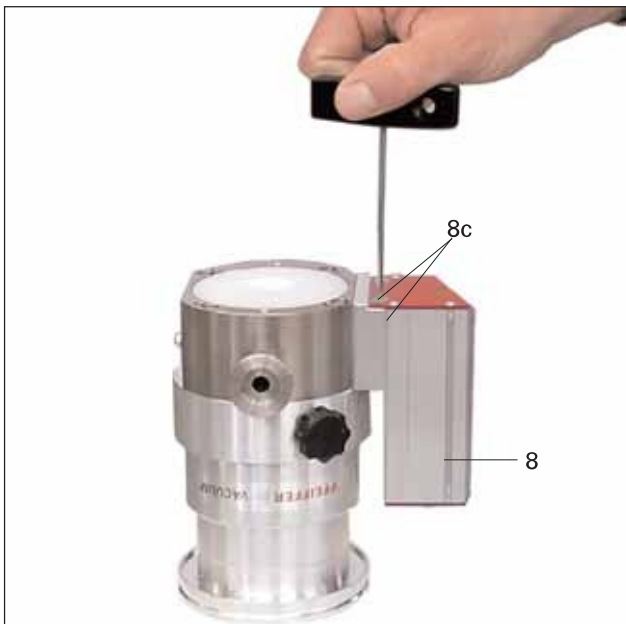

- Remove the Electronic Drive Unit TC 100 (8) from the turbopump.



- Assemble the new Electronic Drive Unit TC 100 (order number please see Section 10. Spare Parts) on the turbopump and connect again.



Please take into account that after replacement the standard operating parameters are always pre-set. If your application requires different parameters, please modify accordingly in addition to the ones stated above.

7.2. Replacing The Lubricant Reservoir

The lubricant reservoir should be replaced at least every three years. Where extreme operating conditions or unclean processes are involved, the replacement interval should be checked with your Pfeiffer Vacuum Service Center.

- Switch off the turbopump, vent to atmospheric pressure (see Section 4.3.) and allow to cool as necessary.
- If necessary, remove the turbopump from the system.
- Unscrew rubber feet 6 from the underside of the pump.
- Unscrew locking cover 90 on the underside of the pump with installation tool E (order number N 5709 103).



- Lever out the lubricant reservoir 92 with the help of two screwdrivers.



- Remove the Porex rods 89 (eight pieces) with tweezers..



Both the lubricant reservoir and the Porex rods can contain toxic substances from the media being pumped. Lubricant reservoirs and Porex rods must be disposed of in accordance with local regulations.

Safety instructions data sheet for the lubricant on request.

- Clean off any dirt on the pump and locking cover with a clean, fluff-free cloth.
- Insert new Porex rods (eight pieces) with tweezers.
- Insert new lubricant reservoir 92 **up to the O-ring 93** in the pump.



The lubricant reservoir comes pre-filled with Lubricant TL 011; do not add additional lubricant.

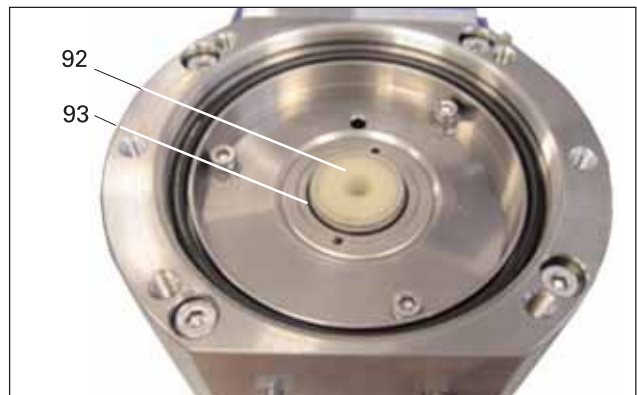

- Screw in locking cover 90. The lubricant reservoir is brought into the correct axial position with the locking cover.
- Screw the rubber feet 6 back in.

8. Service

Do make use of our service facilities

In the event that repairs are necessary a number of options are available to you to ensure any system down time is kept to a minimum:

- Have the pump repaired on the spot by our Pfeiffer Vacuum Service Engineers;
- Return the pump to the manufacturer for repairs;
- Replace the pump.

Local Pfeiffer Vacuum representatives can provide full details.



Please take into account that where Pfeiffer Vacuum Service replacement service is involved the standard operating parameters are always pre-set.

If your application requires different parameters, please modify accordingly.



The turbopump and the Electronic Drive Unit TC 100 form a single unit and must therefore be returned complete for repair purposes. Before returning the unit it should be ensured that the power supply is not the cause of the malfunction (checking the power supply).

Before returning:

- Dismantle all accessories.
- If the unit is free of harmful substances, please attach a clearly visible notice "Free of harmful substances" (both on the unit and also on the delivery note and any accompanying letters).

"Harmful substances" are substances and preparations as defined in the current, local, dangerous substances regulations; in the U.S.A. as

"materials in accordance with the Code of Federal Regulations (CFR) 49 Part 173.240 Definition and Preparation". We will carry out the decontamination and invoice this work to you if you have not attached this note. This also applies where the operator does not have the facilities to carry out the decontamination work. Units which are contaminated microbiologically, explosively or radioactively cannot be accepted as a matter of principle.

Fill out the declaration of contamination

- In every case the "Declaration of Contamination" must be completed diligently and truthfully.
- A copy of the completed declaration must accompany the unit; any additional copies must be sent to your local Pfeiffer Vacuum Service Center.

Please get in touch with your local Pfeiffer Vacuum representatives if there are any questions regarding contamination.



Decontaminate units before returning or possible disposal. Do not return any units which are microbiologically, explosively or radioactively contaminated.

Returning contaminated units

If contaminated have to be returned for maintenance/repair, the following instructions concerning shipping must be followed:

- Neutralise the pump by flushing with nitrogen or dry air.
- Seal all openings to the air.
- Seal pump or unit in suitable protective foil.
- Return equipment only in suitable, rugged shipping containers and by complying with the currently valid shipping regulations.

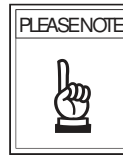

Repair orders are carried out according to our general conditions of sale and supply. If repairs are necessary, please send the pump to your nearest Pfeiffer Vacuum Service Center.

9. Technical Data

Feature	Unit	TMH071 YP	TMH071 YP	TMU071 YP
Connection nominal diameter				
Inlet		DN 40 ISO-KF	DN 63 ISO-K	DN 63 CF-F
Outlet		DN 16 ISO-KF/G 1/4"	DN 16 ISO-KF/G 1/4"	DN 16 ISO-KF/G 1/4"
Venting connection		G 1/8"	G 1/8"	G 1/8"
Nominal rotation speed	Hz (1/min)	1500 (90 000)	1500 (90 000)	1500 (90 000)
Standby rotation speed	Hz (1/min)	1000 (60 000)	1000 (60 000)	1000 (60 000)
Start-up time	min	25	25	25
Max. noise level ¹⁾	dB (A)	48	48	48
Final pressure, backing pump	mbar	< 10	< 10	< 10
Integral leak rate (He) ²⁾	mbar l/s	< 1 · 10 ⁻⁷	< 1 · 10 ⁻⁷	< 1 · 10 ⁻⁷
Maximum permissible rotor temperature	°C	80	80	80
Permissible heat radiation power	W	4	4	4
Volume flow rate for				
Nitrogen N ₂	l/s	33	59	59
Helium He	l/s	39	50	50
Hydrogen H ₂	l/s	32	42	42
Compression ratio for				
N ₂		> 10 ¹¹	> 10 ¹¹	> 10 ¹¹
He		6 · 10 ⁶	6 · 10 ⁶	6 · 10 ⁶
H ₂		> 10 ⁵	1 · 10 ⁵	1 · 10 ⁵
Maximum fore vacuum pressure for				
N ₂	mbar	18	18	18
He	mbar	18	18	18
H ₂	mbar	12	12	12
Maximum gas throughput ³⁾				
With water cooling N ₂	mbar l/s	1.1	1.1	1.1
He	mbar l/s	25	25	25
With air cooling ⁴⁾ N ₂	mbar l/s	0.58	0.58	0.58
Maximum gas throughput at intake pressure of 0.1 mbar ⁵⁾				
With water cooling N ₂	mbar l/s	2	2	2
He	mbar l/s	3	3	3
H ₂	mbar l/s	2	2	2
Vertex power characteristics line ⁶⁾				
A	W / Hz	80 / 1500	80 / 1500	80 / 1500
B	W / Hz	80 / 1500	80 / 1500	80 / 1500
C	W / Hz	60 / 1500	60 / 1500	60 / 1500
D	W / Hz	80 / 1300	80 / 1300	80 / 1300
Final pressure ⁷⁾				
With rotary vane pumps	mbar	< 1 · 10 ⁻⁷	< 1 · 10 ⁻⁷	< 5 · 10 ⁻¹⁰
With diaphragm pumps	mbar	< 1 · 10 ⁻⁷	< 1 · 10 ⁻⁷	< 1 · 10 ⁻⁸
Lubricant		TL011	TL011	TL011
Maximum cooling water consumption with water at 15 °C ⁸⁾	l/h	100	100	100
Cooling water temperature	°C	5- 25	5- 25	5- 25
Permissible ambient temperature with air cooling	°C	5- 40	5- 40	5- 40
Heating power consumption	W	32	32	32
Weight	kg	2.4	2.5	3.8
Permissible magnetic field	mT	3	3	3
Operating voltage	VDC	24 ± 5%	24 ± 5%	24 ± 5%
Duration ⁸⁾ - / max. current consumption	A	4.1 / 4.6	4.1 / 4.6	4.1 / 4.6
Duration ⁸⁾ - / max. power	W	100 / 110	100 / 110	100 / 110
Fuse, internal	V	T8A/250	T8A/250	T8A/250
Protection class ⁹⁾		IP 30	IP 30	IP 30
Shipping and storage temperature	°C	-25 to +55	-25 to +55	-25 to +55
Relative humidity	%	5-85 non-condensing	5-85 non-condensing	5-85 non-condensing

1) Distance from the pump 1 m

2) Measured at a helium concentration of 100%, 10 s measurement time

3) Until frequency falls off below 100 Hz through pump to with reduced rotation speed

4) Until ambient temperature 30 °C

5) Rotation speed of pump may drop below the nominal rotation speed.

6) For gas type characteristic lines please refer to section 4.4

9.1. Dimensions Diagram

TMH071 YP / TMU071 YP

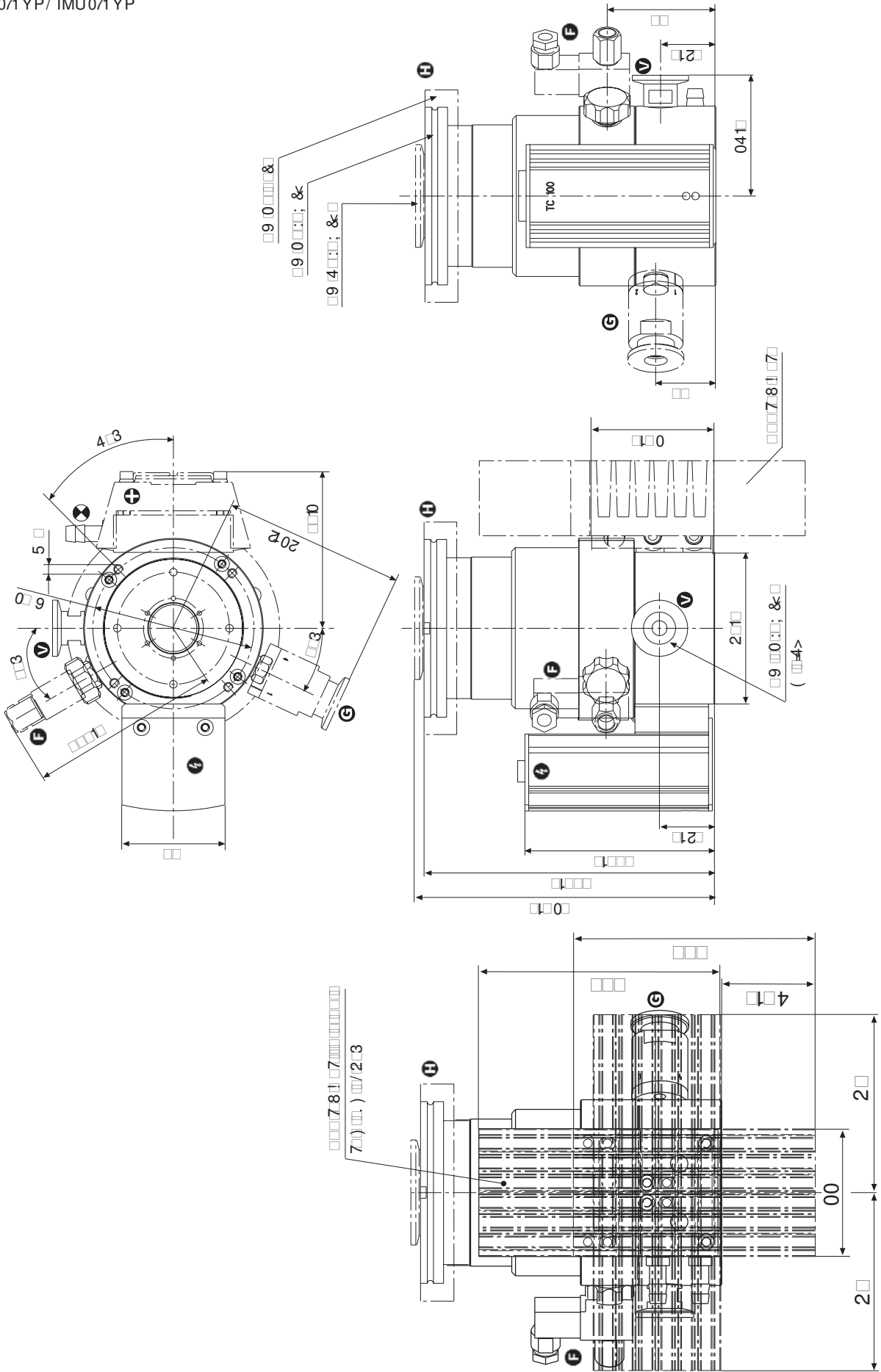

10. Spare Parts

Pos.	Description	Pieces	Size	Number	Comments	Ordering Quantity
	Spare Parts TMH/TMU 071 Y P					
8	Electronic Drive Unit TC100	1		PM C01 692 -A	see section 7.1	
90	Locking cover	1		PM 083 021 -X		
91	O-ring	1	68x3	P 4070 972 PP		
92	Lubricant reservoir (with O-ring 93)	1		PM 103 794 -T	see section 7.2	

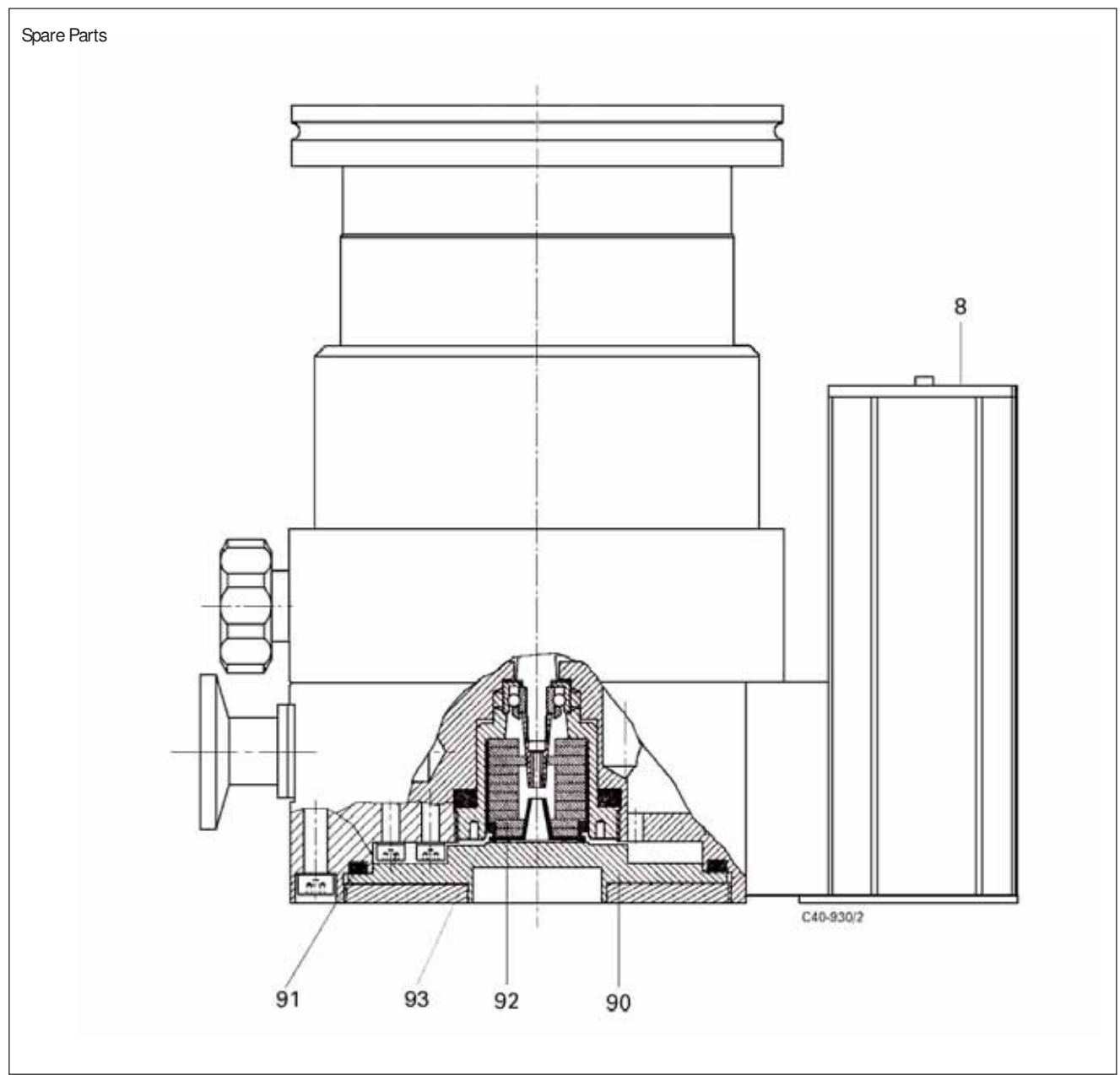

11. Accessories

Description	Size	Number	Comments/ Operating Instructions	Order Quantity
Components for cooling Dirt trap Recycled Water Cooling Unit TZK 400 Air cooling Water cooling Cooling unit (for enhanced convection cooling)	R3/8" 230 V, 50 Hz 24 VDC	P 4161 300 2R PM Z01 245 PM Z01 253 A PM 016 000 -T PM 093 237 -T	PM 0369 BN PM 0543 BN PM 0546 BN	
Components for venting Venting Valve TVF005, without current closed Drying Unit TTV 001 (filled with zeolite) Venting flange	24 VDC DN 10 ISO-KF	PM Z01 135 PM Z00 121 PM 033 737 -T	PM 0507 BN PM 0022 BN	
Components for heating Casing heating	230 V, Schuko plug 208 V, UL-plug 115 V, UL-plug	PM 041 900 -T PM 041 901 -T PM 041 902 -T	Water cooling required/ PM 0542 BN PM 0542 BN PM 0542 BN	
Components for mounting Coated centering ring, bracket screws Coated centering ring with protective screen, bracket screws Coated centering ring with splinter shield, bracket screws Coated centering ring, claw grips Coated centering ring with protective screen, claw grips Coated centering ring with splinter shield, claw grips	DN 63 ISO-K DN 63 ISO-K DN 63 ISO-K DN 63 ISO-K DN 63 ISO-K	PM 016 360-T PM 016 362-T PM 016 361-T PM 016 510-T PM 016 512-T PM 016 511-T	for mounting ISO-K/ISO-K for mounting ISO-K/ISO-K for mounting ISO-K/ISO-K for mounting ISO-K/ISO-F for mounting ISO-K/ISO-F for mounting ISO-K/ISO-F	
Other accessories Connecting cable TC 100 – TPS (without bridge)1) Connecting cable TC 100 – TPS (with bridge)1) Connecting cable TC 100/DCU - TPS1)	3m 3m 3 m	PM 051 541 -T PM 051 421 -T PM 051 431 -T	Other lengths on request; the TMP starts after switching on via DCU/HPU. Other lengths on request; the TMP starts when the power supply is switched on. Other lengths on request	
Power supply – TPS 100; for fitting to walls or standard runners – TPS 100; 19" insert unit – DCU 100; 19" insert unit with Operating and Display Control Unit (DCU)		PM 041 827 -T PM 041 828 -T PM C01 694	PM 0521 BN PM 0521 BN PM 0477 BN	
Mains cable Schuko plug UL plug UL plug	230 V 208 V 115 V	P 4564 309 ZA P 4564 309 ZF P 4564 309 ZE		
15 pole D-Sub plug		P 0998 016	Protection class IP 54 for TC 100	
Operating and Display Control Unit DCU 001 Operating and Display Control Unit HPU 001		PM 041 816 -T PM 051 510 -T	PM 0477 BN PT 0101 BN	
Connection Box TCS 010 Relay box, backing pump Level Converter RS 232/485 Profibus DP gateway TIC 250 Vibration compensator, TMH TMH TMU Splinter shield Protective screen Sealing gas valve Hose nipple for the sealing gas valve	90-265 V (5 A) 90-265 V (20 A) DN 63 ISO-K DN 40 ISO-KF DN 63 CF-F DN 40 ISO-KF DN 63 CF-F DN 63 CF-F DN 16 ISO-KF-10	PM 051 460 -T PM 041 937 -T PM 041 938 -T PM 051 054 -T PM 051 257 -T PM 006 800 -X PM 006 799 -X PM 006 801 -X PM 006 375 -X PM 016 312 PM 016 333 PM Z01 142 PF 144 020	PT 0045 BN PT 0030 BN PT 0030 BN PM 0549 BN PM 0599 BN PM 0229 BN	

1) For application please refer to Section 3.13. Connections Diagram

Declaration of Contamination of Vacuum Equipment and Components

The repair and/or service of vacuum components will only be carried out if a correctly completed declaration has been submitted. Non-completion will result in delay.

The manufacturer could refuse to accept any equipment without a declaration.

This declaration can only be completed and signed by authorised and qualified staff:

1. Description of component:

- Equipment type/model: _____
- Code No.: _____
- Serial No.: _____
- Invoice No.: _____
- Delivery Date: _____

2 Reason for return:

3. Equipment condition

- Has the equipment been used?
yes no
- What type of pump oil was used?

- Is the equipment free from potentially harmful substances?
yes (go to section 5)
no (go to section 4)

4. Process related contamination of equipment

- toxic yes no
- corrosive yes no
- microbiological hazard*) yes no
- explosive*) yes no
- radioactive*) yes no
- other harmful substances yes no

*) We will not accept delivery of any equipment that has been radioactively or microbiologically contaminated without written evidence of decontamination!

Please list all substances, gases and by-products which may have come into contact with the equipment:

Tradename Product name Manufacturer	Chemical name (or Symbol)	Danger class	Precautions associated with substance	Action if spillage or human contact
1.				
2.				
3.				
4.				
5.				

5. Legally Binding Declaration

I hereby declare that the information supplied on this form is complete and accurate. The despatch of equipment will be in accordance with the appropriate regulations covering Packaging, Transportation and Labelling of Dangerous Substances.

Name of Organisation: _____

Address: _____ Post code: _____

Tel.: _____

Fax: _____ Telex: _____

Name: _____

Job title: _____

Date: _____ Company stamp: _____

Legally binding signature: _____



Declaration of conformity

according to the EC directive:

- Machinery 2006/42/EC (Annex II, no. 1 A)

We hereby declare that the product cited below satisfies all relevant provisions of EC directive "Machinery" 2006/42/EC.

In addition, the product cited below satisfies all relevant provisions of EC directive "Electromagnetic Compatibility" 2004/108/EC.

The agent responsible for compiling the technical documentation is Mr. Jörg Stanzel, Pfeiffer Vacuum GmbH, Berliner Straße 43, 35614 Asslar.

TMH 071 Y P / TMU 071 Y P

Guidelines, harmonised standards and national standards and specifications which have been applied:

DIN EN ISO 12100-1 : 2004
DIN EN ISO 12100-2 : 2004
DIN EN ISO 14121-1 : 2007
DIN EN 1012-2 : 1996
DIN EN 61010-1 : 2002

Signatures:

Pfeiffer Vacuum GmbH
Berliner Straße 43
35614 Asslar
Germany

(M. Bender)
Managing Director

(Dr. M. Wiemer)
Managing Director

CE/2010

Vacuum is nothing, but everything to us!



Turbopumps



Rotary vane pumps



Roots pumps



Dry compressing pumps



Leak detectors



Valves



Components and feedthroughs



Vacuum measurement



Gas analysis



System engineering



Service



