

# TURBOLAB

TURBOLAB 80, 350, 450

Turbomolecular Pump Systems

Operating Instructions 300554859\_002\_A0

Part Nos.

501592Vxxxxxxxx

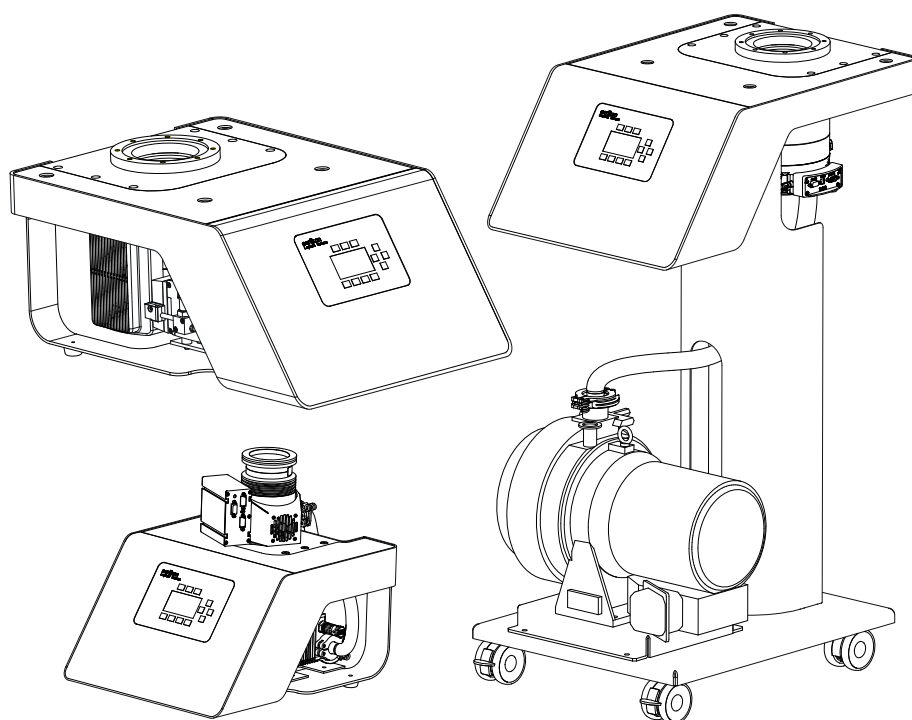

# Contents

	<b>Page</b>	
<b>0</b>	<b>Important Safety Information</b>	<b>5</b>
0.1	Mechanical Hazards	5
0.2	Electrical Hazards	5
0.3	Hazards Caused by Materials and Substances	6
0.4	Danger of Damages to the Pump System	6
<b>1</b>	<b>Description</b>	<b>8</b>
1.1	Design	8
1.2	Standard Specification	9
1.3	Technical Data	11
1.3.1	Backing pumps	11
1.3.2	Pump systems	11
	Product identification	11
1.4	Ordering Information	14
1.5	Accessories	15
<b>2</b>	<b>Transport and Storing</b>	<b>18</b>
<b>3</b>	<b>Installation</b>	<b>19</b>
3.1	Placement	19
3.2	Conforming Use	19
3.3	Ambient Conditions	19
3.4	High Vacuum Connection	20
3.4.1	Removing the TURBOVAC Pump from the Pump System	21
3.5	Connecting the Exhaust Line	23
3.6	Connect the Cooling	23
3.6.1	Cooling Water	24
3.7	Connect a Power Failure Venting Valve or a Venting Valve	26
3.8	Connect Purge Gas	27
3.9	Connect a Flange Heater	28
3.10	Connect a Gauge	29
3.11	Connect a PC/Mobile Device	29
3.12	Electrical Connection	30

Original operating instructions (no translation)

<b>4</b>	<b>Operation</b>	<b>31</b>
4.1	Media Compatibility / Purge Gas	31
4.2	Start-up	31
4.3	Interfaces	32
4.4	Switching On	34
4.5	Operation	35
4.5.1	Menu	35
4.5.2	Function Codes of the Accessory Connections	39
4.5.3	Relay Functions	45
4.5.4	Parameter list	46
4.5.5	Monitoring of the Operation Conditions	48
4.6	Shut-down	48
4.7	Venting	49
4.8	Bakeout	50
4.9	Webserver	51
4.10	DataViewer	60
<b>5</b>	<b>Maintenance</b>	<b>64</b>
5.1	Cleaning	64
5.2	Oil of the Rotary Vane Pump	65
5.3	Removing the Forevacuum Pump	65
5.4	Oerlikon Leybold Vacuum Service	65
<b>6</b>	<b>Troubleshooting</b>	<b>66</b>
<b>7</b>	<b>Waste Disposal</b>	<b>69</b>
	<b>EC Declaration of Conformity</b>	<b>70</b>

# Safety Information

---

## NOTICE



### Obligation to Provide Information

Before installing and commissioning the pump system, carefully read these Operating Instructions and follow the information so as to ensure optimum and safe working right from the start.

The Oerlikon Leybold Vacuum **turbomolecular pump system** has been designed for safe and efficient operation when used properly and in accordance with these Operating Instructions. It is the responsibility of the user to carefully read and strictly observe all safety precautions described in this section and throughout the Operating Instructions. The pump system must only be operated in the proper condition and under the conditions described in the Operating Instructions. It must be operated and maintained by trained personnel only. Consult local, state, and national agencies regarding specific requirements and regulations. Address any further safety, operation and/or maintenance questions to our nearest office.

---

## DANGER



DANGER indicates an imminently hazardous situation which, if not avoided, will result in death or serious injury.

---

## WARNING



WARNING indicates a potentially hazardous situation which, if not avoided, could result in death or serious injury.

---

## CAUTION



CAUTION indicates a potentially hazardous situation which, if not avoided, could result in minor or moderate injury.

---

## NOTICE



NOTICE is used to notify users of installation, operation, programming or maintenance information that is important, but not hazard related.

---

We reserve the right to alter the design or any data given in these Operating Instructions. The illustrations are not binding.

Retain the Operating Instructions for further use.

# Safety Information

## 0 Important Safety Information

Note also the safety information given for the individual pumps and components.

### 0.1 Mechanical Hazards

- 1 Avoid exposing any part of the human body to the vacuum.
- 2 The pressure in the pump system must not exceed atmospheric pressure.
- 3 The pump system is intended for generating a vacuum only. If there is a risk of an overpressure within the system and the pump, then it must be protected against this, by way of an overpressure safety valve, for example.
- 4 The maximum pressure on the inlet side must not exceed atmospheric pressure (approximately 1013 mbar).
- 5 While the pump is running, the exhaust of the backing pump must not be blocked in any way and the pressure in the exhaust line must not exceed atmospheric pressure.
- 6 After having removed the Plexiglas panel do not reach into the turbomolecular pump since there is the risk of suffering injury at sharp edges.
- 7 Operate the pump system only after having connected it to the corresponding piping first.
- 8 The turbomolecular pump must, when removed from the pump system, always be firmly attached to a vacuum chamber. If the mounting is not sturdy enough, pump blockage could cause the pump to break loose; internal pump components could be thrown in all directions. Never operate the pump (in bench testing, for example) without proper flanging to the vacuum chamber.
- 9 The pump system must only be detached from the vacuum chamber and moved, provided the pump has been allowed to run down completely and is at a full standstill.

---

#### WARNING



### 0.2 Electrical Hazards

- 1 The system must only be connected to a power supply the specifications of which match those stated on the nameplate.
- 2 Do not open the switchbox and do not remove any covers from the electrical equipment. Do not disconnect any earth connections.

---

#### WARNING



# Safety Information



## DANGER

### 0.3 Hazards Caused by Materials and Substances

- 1 The product in its standard version is not suited for operation in explosion hazard areas.
- 2 The product is not suited for pumping of
  - combustible and explosive gases and vapours
  - radioactive and toxic gases and vapours
  - pyrophorous substances
  - oxygen which exceeds the concentration in the atmosphere (> 21%).
- 3 When using oil lubricated backing pumps, there is the risk of escaping oil mist. Use a suitable exhaust filter or an exhaust line, see Accessories.
- 4 If the system has previously pumped hazardous gases take the appropriate safety measures before opening the intake or exhaust ports. Use gloves, a breathing mask or protective clothing and work under a fume hood.

---

## NOTICE



### 0.4 Danger of Damages to the Pump System

- 1 The pump system is not suited for pumping of liquids or of dusty, aggressive or corrosive media.
  - 2 The pump system must only be detached from the vacuum chamber and moved, provided the pump has been allowed to run down completely and is at a full standstill.
  - 3 Exposure of the pump to accelerating forces must be avoided or reduced to such an extent that the rotor unit will not be excited by vibrations. In the case of critical applications you must consult our Applications Dept. first.
  - 4 The pump must only be opened by such persons who have been authorised by Oerlikon Leybold Vacuum to do so.
  - 5 Ensure that no items like bolts, nuts, washers, pieces of wire, for example, enter into the inlet of the pump. Foreign objects which enter into the pump will generally cause severe damage. Damage caused by the intake of foreign objects is not covered by our warranty.
  - 6 The equipment must not be exposed to drip or spray water.
-

# Description

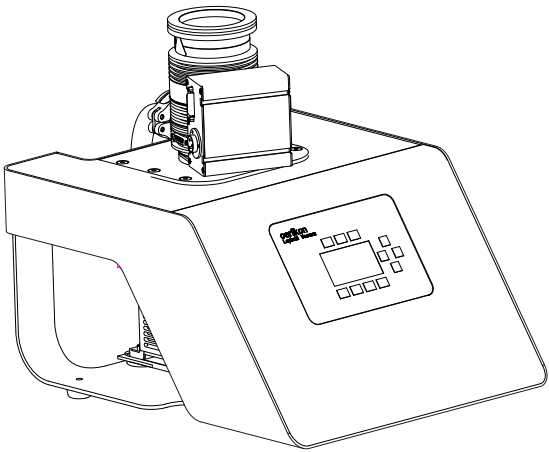

TURBOLAB 80

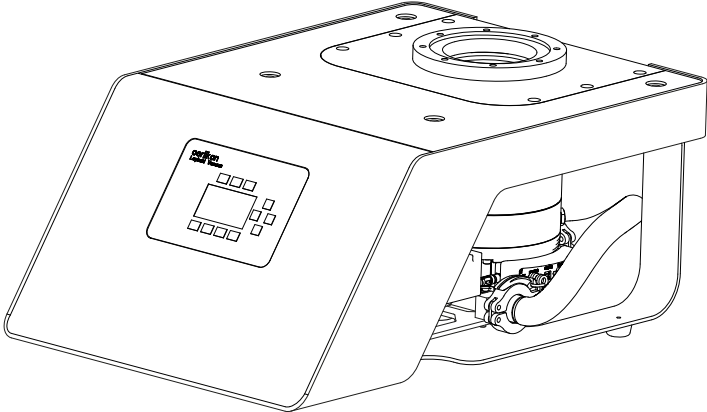

TURBOLAB 350/450

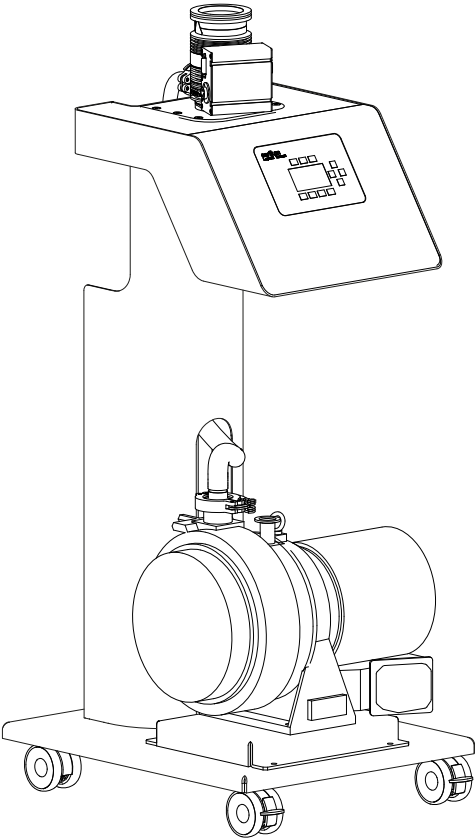

TURBOLAB 80 Cart

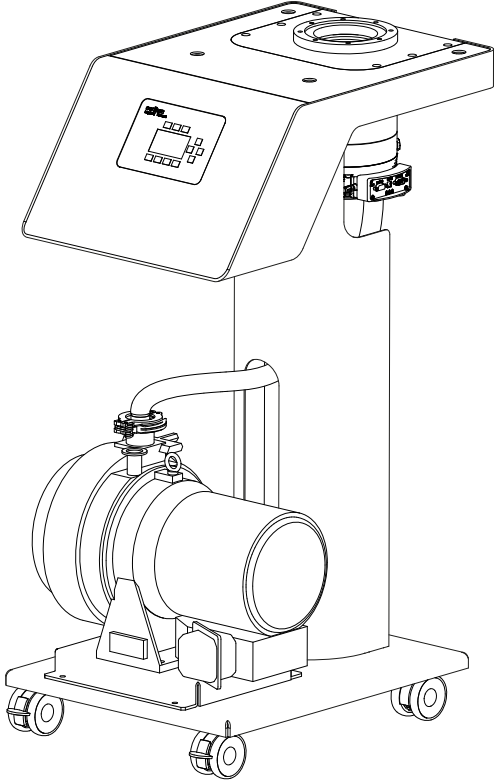

TURBOLAB 350/450 Cart

Fig. 1.1 Turbomolecular pump systems TURBOLAB

# Description

## 1 Description

The TURBOLAB pump systems are turnkey vacuum units for pumping vacuum vessels to pressures in the high-vacuum range.

### 1.1 Design

The TURBOLAB pump systems consist of the following components as standard:

- Turbomolecular pump TURBOVAC

The TURBOVACs are turbomolecular pumps with lifetime lubricated ceramic ball bearings. A built-in thermal switch switches off the TURBOVAC if the permissible temperature is exceeded.

- The frequency converter is integrated into the TURBOVAC and is supplied with 24 VDC and controlled via RS 485 interface by the TURBOLAB.

- Backing pump

The **TRIVAC** is a two-stage rotary vane pump. It is fitted with a gas ballast valve and an anti-suckback valve. The anti-suckback valve shuts off the vacuum line to the turbomolecular pump in the event of power failure or when the unit is switched off.

The **SOGEVAC** SV 16 D and SV 25 D are single stage, oil-sealed rotary vane pumps. The anti-suckback valve, gas ballast valve and an exhaust filter, oil return circuit are integrated functional elements of the SOGEVAC.

The **SCROLLVAC** pumps are dry compressing scroll pumps.

The **DIVAC** pumps are two to four-stage, oil-free diaphragm pumps.

- Vacuum connection between TURBOVAC and backing pump: flexible stainless-steel line. The connection can be broken, for example to enable an adsorption trap to be fitted.

- Frames: Cart with baseplate, mounting column & castors or benchtop frame with rubber feet.

- TPU Turbo Pressure Unit

Every TURBOLAB comes standard with the TPU for control, configuration & monitoring of the turbomolecular pump system.

The backing pump is connected depending on the specific type at X211 (110/230VAC) or at X20 (24VDC) and it starts when the turbomolecular pump is started.

A safety valve can be connected at X210 (110/230VAC) and this safety valve is switched in parallel with the backing pump.

The function for the accessory connection is set by default to "Active at Start Command" and this setting can be changed through Menu → Accessory → VV Pump.



The turbomolecular pump systems are designed to mount further components:

- vacuum gauges: TTR 101, TTR 91, PTR 91, TTR 101N, TTR 91N, PTR 91N. Two vacuum gauges can be operated simultaneously.
- adsorption trap
- exhaust filter
- air cooling
- water cooling
- flange heater
- vent valve
- purge valve
- foreline safety valve: SECUVAC Valve DN 16/25/40 ISO-KF

Fitting of further components beyond the scope detailed here requires an approval from OLV.

## **1.2 Standard Specification**

The following are supplied with the pump system:

- Transport lock at the high vacuum flange by way of a Plexiglas disc
- Covering caps for the threads of the transport lock
- exhaust side: centering ring and clamping ring
- documentation
- The TRIVAC and SOGEVAC are filled with LVO oil.

# Description

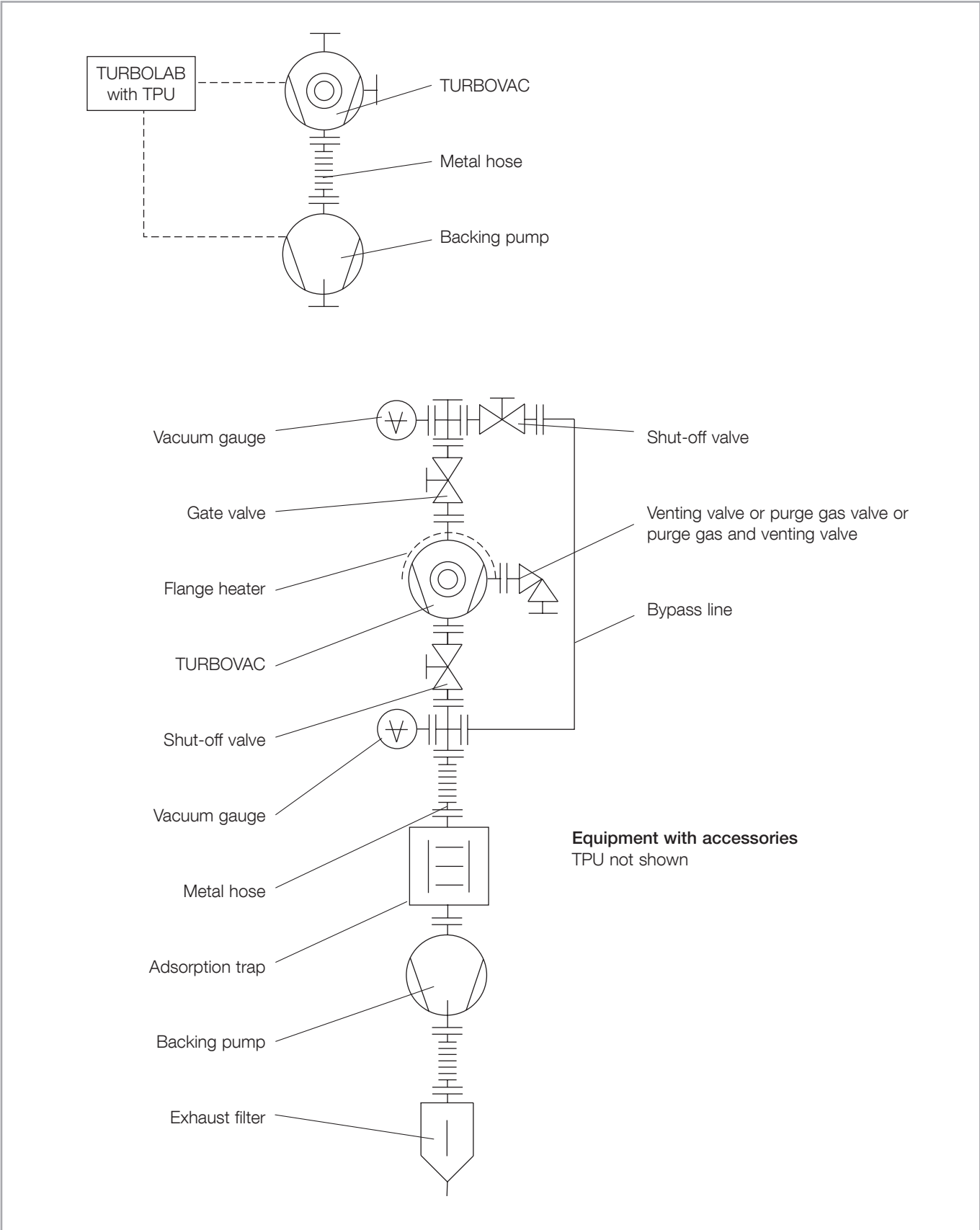

Fig. 1.2 Schematic diagram of the turbomolecular pump systems TURBOLAB

## 1.3 Technical Data

### 1.3.1 Backing pumps

Backing pump	0.8 T	DIVAC			SCROLLVAC			TRIVAC		SOGEVAC	ECODRY+
		3.0	3.8 HV		SC 5 D	SC 15 D	SC 30 D	D 4 B	D 8 B	SV 16 D	65
Pumping speed	m <sup>3</sup> ·s <sup>-1</sup>	0.7	3.0	3.4	5.4	15.0	30.0	4.8	9.7	16	56
Noise level	dB(A)	49	54	54	52	58	62	52	52	59	< 59
Exhaust connection	Silencer	?	Hose nozzle ID 10		DN 16 KF	DN 16 KF	DN 25 KF	DN 16 KF	DN 16 KF	G 1/2" thread	DN 25 KF

### 1.3.2 Pump systems

		TURBOLAB 80		TURBOLAB 350		TURBOLAB 450	
Inlet flange	DN	63 ISO-K	63 CF	100 ISO-K	100 CF	160 ISO-K	160 CF
Forevacuum connection	DN	16 KF	16 KF	25 KF	25 KF	25 KF	25 KF
Pumping speed	l·s <sup>-1</sup>	65	65	290	290	430	430
Ultimate pressure	mbar	10 <sup>-7</sup>	10 <sup>-7</sup>	10 <sup>-8</sup>	10 <sup>-10</sup>	10 <sup>-8</sup>	10 <sup>-10</sup>
Mains Supply 50/60Hz	V	110 ± 10 % / 220 ± 10 %					
Rated power consumption, max.	VA			1760 3680	1760 3680		

### Product identification

To correctly identify the product when communicating with Oerlikon Leybold Vacuum, always have the information from the rating plate available.



Fig. 1.3 Example for a rating plate

# Description

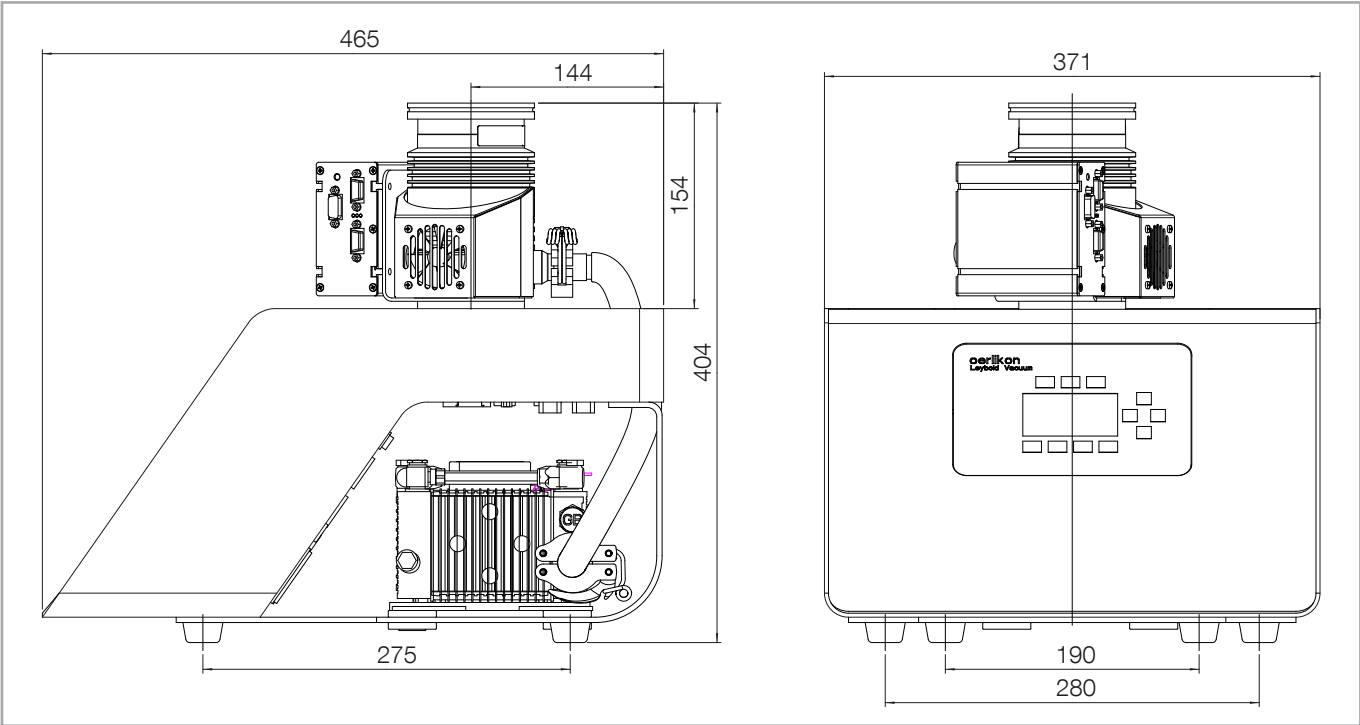

Fig. 1.4 Dimensional drawing TURBOLAB 80, dimensions in mm

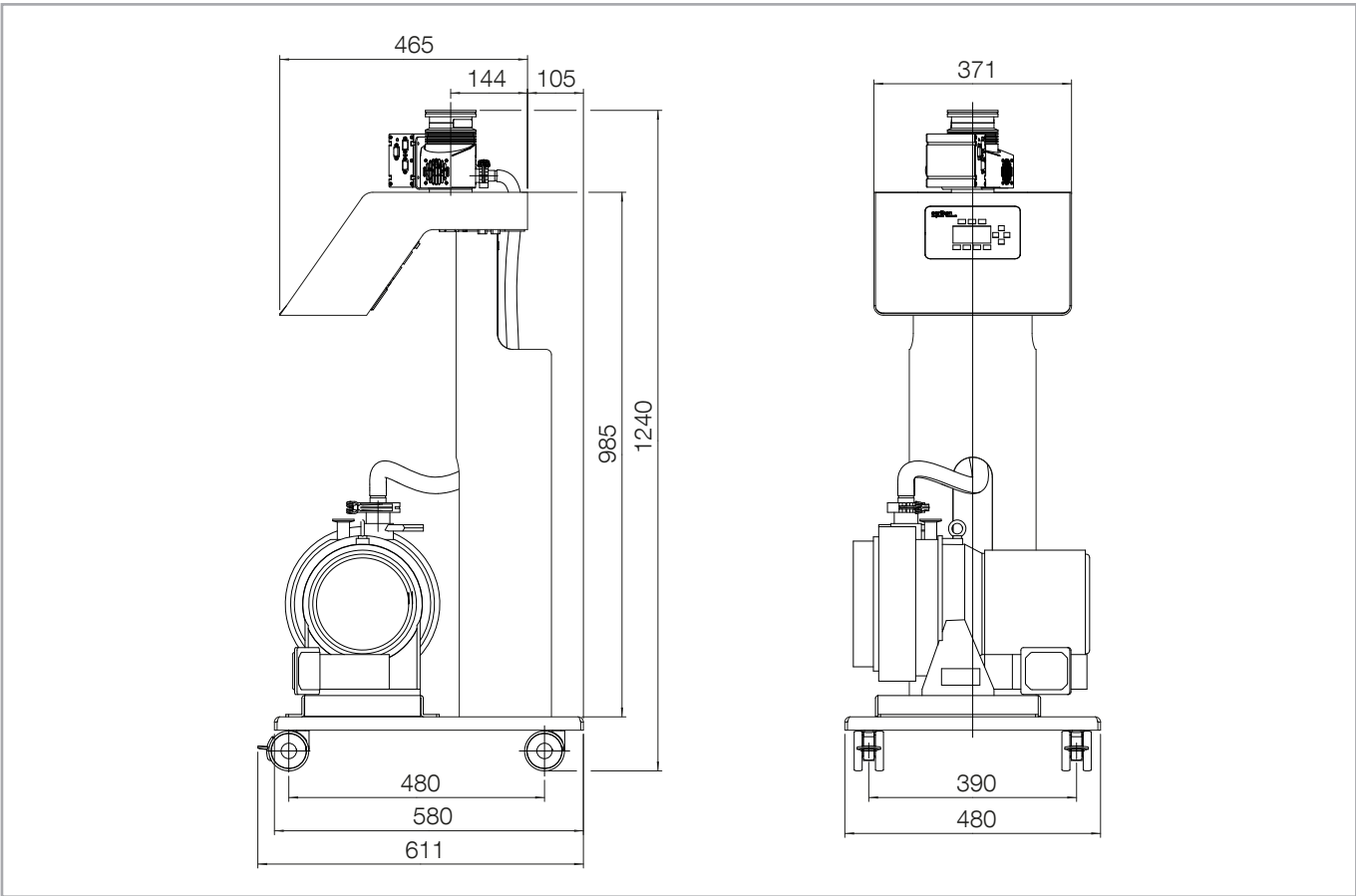

Fig. 1.5 Dimensional drawing TURBOLAB 80 Cart, dimensions in mm

# Description

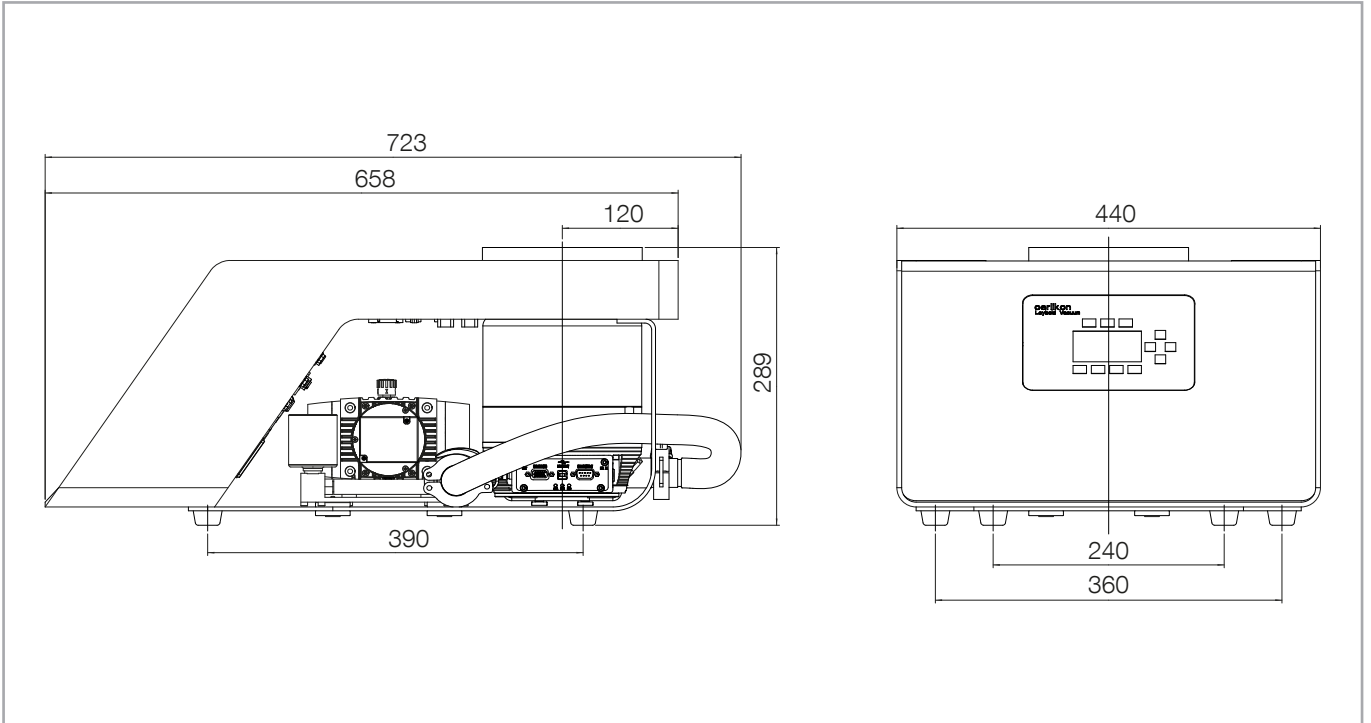

Fig. 1.6 Dimensional drawing TURBOLAB 350/450, dimensions in mm

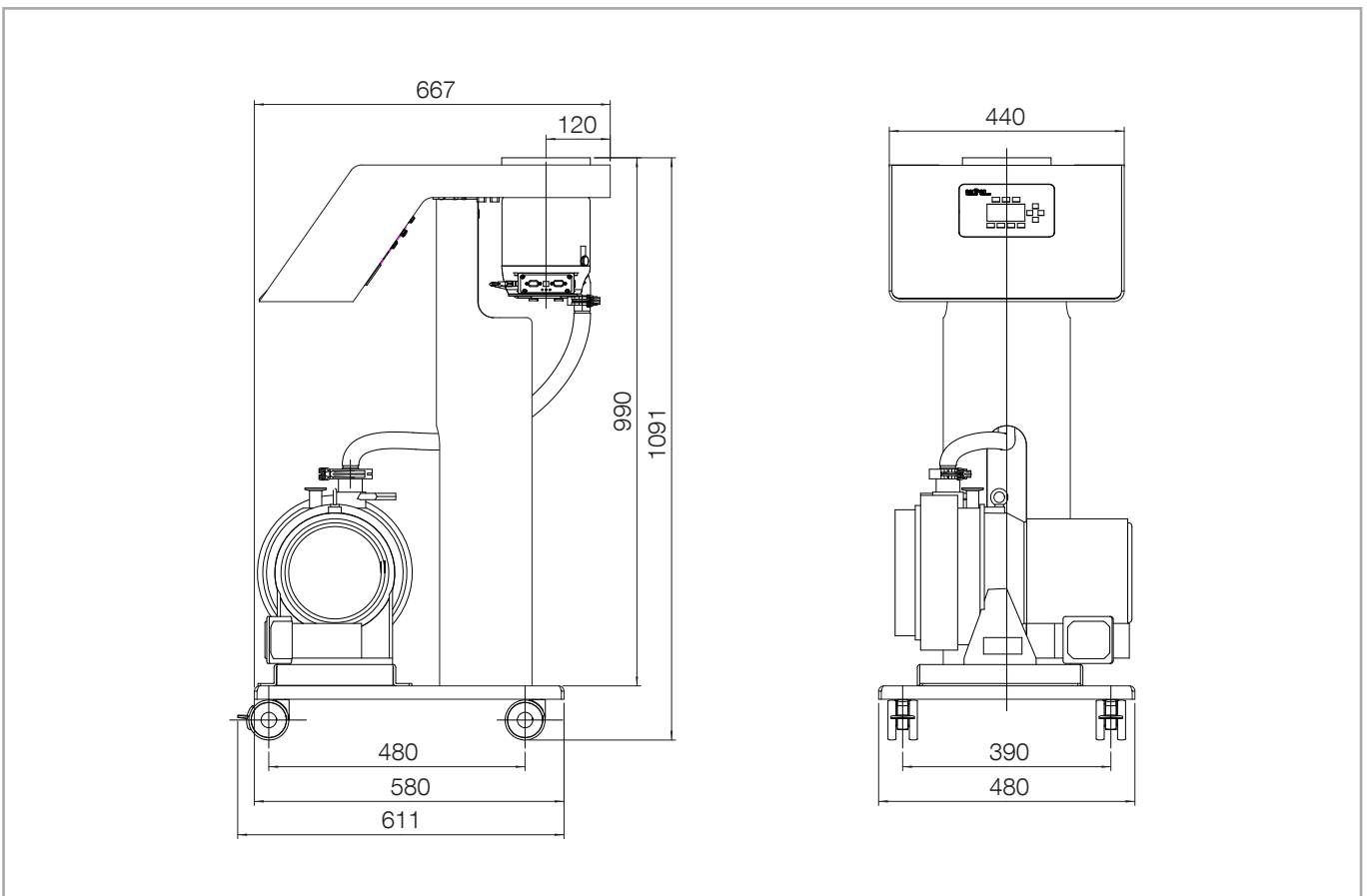

Fig. 1.7 Dimensional drawing TURBOLAB 350/450 Cart, dimensions in mm

# Description

## 1.4 Ordering Information

Pump System	TURBOVAC & Frequency converter	Backing Pump	High Vacuum Connection	Frame	Part No. 230 V 50/60 Hz	Part No. 110 V 50/60 Hz
TURBOLAB 80	SL 80 H, TD 400	DIVAC 0.8 T	DN 63 ISO-K	Table	501592V02000000	
			DN 63 CF		501592V03000000	
		DIVAC 3.0	DN 63 ISO-K		501592V02001000	
			DN 63 CF		501592V03001000	
		DIVAC 3.8 HV	DN 63 ISO-K	501592V02010000		
			DN 63 CF	501592V03010000		
		SCROLLVAC SC 5 D	DN 63 ISO-K	501592V02020000	501592V02030000	
			DN 63 CF	501592V03020000	501592V03030000	
		SCROLLVAC SC 15 D	DN 63 ISO-K	501592V02040000	501592V02050000	
			DN 63 CF	501592V03040000	501592V03050000	
		SCROLLVAC SC 30 D	DN 63 ISO-K	501592V02060000	501592V02070000	
			DN 63 CF	501592V03060000	501592V03070000	
		TRIVAC D 4 B	DN 63 ISO-K	501592V02080000		
			DN 63 CF	501592V03080000		
		TRIVAC D 8 B	DN 63 ISO-K	501592V02090000		
			DN 63 CF	501592V03090000		
SOGEVAC SV 16 D	DN 63 ISO-K	501592V02100000				
	DN 63 CF	501592V03100000				
ECODRY+	DN 63 ISO-K	501592V02110000	-			
	DN 63 CF	501592V03110000	-			

Pump System	TURBOVAC & Frequency converter	Backing Pump	High Vacuum Connection	Frame	Part No. 230 V 50/60 Hz	Part No. 110 V 50/60 Hz
TURBOLAB 350	350 i	DIVAC 3.0	DN 100 ISO-K	Table	501592V04001000	
			DN 100 CF		501592V05001000	
		DIVAC 3.8 HV	DN 100 ISO-K		501592V04010000	
			DN 100 CF		501592V05010000	
		SCROLLVAC SC 5 D	DN 100 ISO-K	501592V04020000	501592V04030000	
			DN 100 CF	501592V05020000	501592V05030000	
		SCROLLVAC SC 15 D	DN 100 ISO-K	501592V04040000	501592V04050000	
			DN 100 CF	501592V05040000	501592V05050000	
		SCROLLVAC SC 30 D	DN 100 ISO-K	501592V04060000	501592V04070000	
			DN 100 CF	501592V05060000	501592V05070000	
		TRIVAC D 4 B	DN 100 ISO-K	501592V04080000		
			DN 100 CF	501592V05080000		
		TRIVAC D 8 B	DN 100 ISO-K	501592V04090000		
			DN 100 CF	501592V05090000		
		SOGEVAC SV 16 D	DN 100 ISO-K	501592V04100000		
			DN 100 CF	501592V05100000		
ECODRY+	DN 100 ISO-K	501592V04110000	-			
	DN 100 CF	501592V05110000	-			



# Description

Pump System	TURBOVAC & Frequency converter	Backing Pump	High Vacuum Connection	Frame	Part No. 230 V 50/60 Hz	Part No. 110 V 50/60 Hz
<b>TURBOLAB 450</b>	450 i	DIVAC 3.0	DN 160 ISO-K	Table	501592V06001000	
			DN 160 CF		501592V07001000	
		DIVAC 3.8 HV	DN 160 ISO-K	501592V06010000		
			DN 160 CF	501592V07010000		
		SCROLLVAC SC 5 D	DN 160 ISO-K	501592V06020000	501592V06030000	
			DN 160 CF	501592V07020000	501592V07030000	
		SCROLLVAC SC 15 D	DN 160 ISO-K	501592V06040000	501592V06050000	
			DN 160 CF	501592V07040000	501592V07050000	
		SCROLLVAC SC 30 D	DN 160 ISO-K	501592V06060000	501592V06070000	
			DN 160 CF	501592V07060000	501592V07070000	
		TRIVAC D 4 B	DN 160 ISO-K	501592V06080000		
			DN 160 CF	501592V07080000		
		TRIVAC D 8 B	DN 160 ISO-K	501592V06090000		
			DN 160 CF	501592V07090000		
SOGEVAC SV 16 D	DN 160 ISO-K	501592V06100000				
	DN 160 CF	501592V07100000				
ECODRY+	DN 160 ISO-K	501592V06110000	-			
	DN 160 CF	501592V07110000	-			

## 1.5 Accessories

	Part No. for TURBOLAB 80	Part No. for TURBOLAB 350/450
Mains cable TURBOLAB 230 V, 5 m	800103V0030	800103V0030
Mains cable TURBOLAB 110 V, 5 m	800103V0031	800103V0031
Accessory cable TURBOVAC i, M8-M8, 0.3 m	800103V0001	800103V0001
Accessory cable TURBOVAC i, M8-M8, 2 m	800110V0016	800110V0016
Y cable TURBOVAC i, M8	800110V0020	800110V0020
Start stop switch for TMP for connection to X1 Remote	800110V0021	800110V0021
USB cable 2.0 Type A/B, 1.8 m	800110V0108	800110V0108
Accessory cable TURBOLAB, M8 - M8, 0.3 m	800103V0001	800103V0001
Accessory cable TURBOLAB, M8 - M8, 5m	800103V0003	800103V0003
Accessory cable TURBOLAB, M12 - M12, 5 m	800103V0005	800103V0005
Accessory cable TURBOLAB, C14 - NEMA, 5 m	800103V0008	800103V0008
Accessory cable TURBOLAB, C14 - Schuko, 5 m	800103V0011	800103V0011
Accessory cable TURBOLAB, C14 - C16-1 (230 V), 5 m	800103V0014	800103V0014
Accessory cable TURBOLAB, C14 - C16-1 (110 V), 5 m	800103V0016	800103V0016
Accessory cable TURBOLAB, C13 - C14, 5 m	800103V0017	800103V0017
Accessory cable TURBOLAB - TURBOVAC i, 5 m	-	800103V0020
Accessory cable TURBOLAB - TD 400, 5 m	800103V0023	-

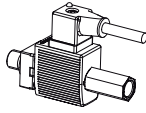
# Description

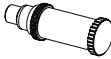
	<b>Part No. for TURBOLAB 80</b>	<b>Part No. for TURBOLAB 350/450</b>
Communication TURBOLAB - TMP, 5 m	800103V0029	800103V0029
Communication TURBOLAB - TMP, 1 m	800103V0027	800103V0027
TURBOLAB, C14 - NEMA, 0,5 m	800103V0006	800103V0006
TURBOLAB, C14 - Schuko, 0,5 m	800103V0009	800103V0009
TURBOLAB, C14 - C16-1, 1,8 m (230 V)	800103V0012	800103V0012
TURBOLAB, C14 - C16-1, 1,8 m (110 V)	800103V0013	800103V0013
TURBOLAB, C13 - C14, 1,8 m	800103V0015	800103V0015
Mains cable TURBOLAB - TMP 350 i, 0.55 m	-	800103V0018
Mains cable TURBOLAB - TD 400, 0.55 m	800103V0021	-
Connection cable Type A, 1.5 Meter	800103V0032	800103V0032
Connection cable Type A, 5 Meter	12426	12426
LEYASSIST software for TMPs	230439V01	230439V01
Air cooling TURBOVAC 350-450 i radial	-	800136V0005
Water cooling TURBOVAC 350/450	-	800135V0005
Water cooling with G 1/8"connections incl. 2 hose nipples G 1/8", Outer Ø 8 mm for water hose, 2 sealing rings approx. 10x4x1, screws	800135V0001	-
Air cooler 4 screws M4x10, DIN 912	800136V0001	-
For TURBOVAC i:		800120V0012
Venting valve, 24 V DC, G 1/8"		800120V0022
Power failure venting valve 24 V DC, G 1/8"		800120V0013
Purge gas valve, 24 V DC, G 1/8", 24 sccm		
Purge gas throttle, G 1/8", 24 sccm		800120V0014
Air filter for TMP, G 1/8"		800110V0022

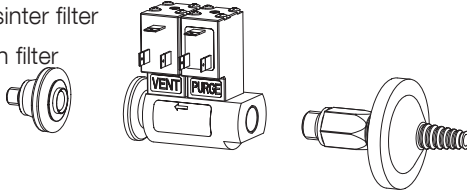
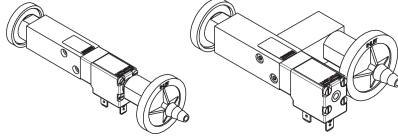

# Description

	Part No. for TURBOLAB 80	Part No. for TURBOLAB 350/450
For TURBOVAC 80 SL:		
Purge gas and venting valve 0,4 mbar-l/s at 1 bar, 24 V DC DN 10 KF – G1/4"	800152V0013	–
Pump connection: Adapter M8 – DN-16-KF incl. O-ring 9.25 x 1.78 and Adapter centering ring DN 10/16 KF with sinter filter	800110V0011	
Gas side connection: G1/4-in. adapter with filter Including O-ring and gasket	800110V0012	
Connection cable: Accessory cable M8 – bare wire ends	800110V0017	
		
Note: For space reasons, when the frequency converter is installed at the side, only either the air-cooler or a purge gas valve can be connected.		
Venting valve 24 V DC	800120V0011	–
Power failure venting valve 24 V DC	800120V0021	
Spare filter	E 200 18 517	
		
Flange heater DN 63 CF, 230 V	854 04	–
Flange heater DN 63 CF, 110 V	854 07	–
Flange heater DN 100 CF, 230V	–	800137V0005
Flange heater DN 100 CF, 115V	–	800137V0006
Flange heater DN 160 CF, 230V	–	800137V0007
Flange heater DN 160 CF, 115V	–	800137V0008
Vibration absorber DN 100 ISO-K	–	800131V1100
other flange sizes	on request	on request
Centering ring with coarse inlet screen DN 100 ISO-K		800133V0021
Centering ring with splinter guard DN 100 ISO-K		800133V0022
Centering ring with coarse inlet screen DN 160 ISO-K		800133V0031
Centering ring with splinter guard DN 160 ISO-K		800133V0032
Inlet screen DN 63 ISO-K	E 200 17 170	–
Inlet screen DN 63 CF	E 200 17 171	–
Coarse inlet screen DN 100 CF (3,2 mm)	–	800132V0021
Splinter guard DN 100 CF (0,8 mm)	–	800132V0022
Coarse inlet screen DN 160 CF (3,2 mm)	–	800132V0031
Splinter guard DN 160 CF (0,8 mm)	–	800132V0032

# Transport and Storing

## 2 Transport and Storing

Remove the equipment from the transportation box and keep the packaging. Make sure that the product has not been damaged during transportation. If this unit is damaged contact your carrier and inform Oerlikon Leybold Vacuum if necessary. For storage of the product, use the packaging provided.

The pump system must only be detached from the vacuum chamber and moved, provided the pump has been allowed to run down completely and is at a full standstill.

When carrying or lifting the pump system take hold of it only at its base panel or transport it at the crane eye. Pump systems on castors may also be rolled on level and smooth surfaces. After having moved the pump system, lock the front castors.

The pump system may be tilted by 10° maximum.

---

### CAUTION



When lifting and setting down the pump system do not reach under it; hands and feet could be pinched. Do not stand under the suspended pump system while it is being moved.

---

### NOTICE



Do not use the piping or other components to lift or move the pump system.

Do not remove the covers and blanking flanges until you are ready to make the connections, to ensure that the turbomolecular pump is installed under the cleanest possible conditions.

Store the system only after it has been vented with dry air or nitrogen. Place dry cartridges into the flanges and seal the system. Store it at a dry place at -20 to 60 °C and at 95 % max. air humidity, non-condensing.

## 3 Installation

### 3.1 Placement

#### Table Pump Systems

Carry or lift the pump system only by lifting it at the frame or at the crane eye. Install the pump system on a level, smooth surface, which is sufficiently large.

#### Cart Pump Systems

Unpack the pump system by lifting it at the crane eye. Afterwards unscrew the crane eye and put the cover supplied onto the column. Install the pump system on a level, smooth surface; lock the front castors.

#### All pump systems

The high-vacuum connection must be as close as possible to the vacuum vessel.

Install the pump system such that a clearance of at least 10 cm is left on each side of the pump system for ventilation.

The noise level when the pumps are running is below 70 dB(A). No acoustic insulation is required.

The area around the controls (on/off switches, for example) must remain freely accessible.

Check the installation place regularly as to escaping oil so as to reduce the risk of slipping.

### 3.2 Conforming Use

The turbomolecular pump systems TURBOLAB are turnkey vacuum units for pumping vacuum vessels to pressures in the high-vacuum range.

The standard versions are not suitable for pumping dusty, aggressive or corrosive media. Please consult us. Note also Section 0.3 Hazards Caused by Materials and Substances.

Note also the information on conforming utilization given for the individual pumps and components.

### 3.3 Ambient Conditions

The magnetic field and the radiation at the pump system must not be too strong. For this refer to the Operating Instructions of the turbomolecular pump.

The ambient temperature should be between 12 °C and 35 °C.

Places of installation up to 1000 m above sea level (3300 ft) are possible without restrictions. At altitudes over 1000 m heat dissipation by the ambient air is impaired. Please consult us.

The pump system must not be operated in explosive gas atmospheres. The standard version of the product is not suited for operation in explosion hazard areas.

# Installation

The pump system must only be used in indoor rooms. Protect the pump system and the connecting lines against splash water and condensing water.

## 3.4 High Vacuum Connection

---

### CAUTION



Never touch the rotor of the TURBOVAC. Touching the rotor may cause injury and damage the rotor bearing.

The TURBOVAC must only be operated after it has been connected to a vacuum chamber or piping or after it has been firmly blanked off with a blank flange. If after the installation there remains the risk of accessing the rotor, then an inlet screen must be fitted.

Do not start the TURBOVAC at atmospheric pressure.

---

Do not remove the transport covers on the pump until shortly before fitting, to ensure that the TURBOVAC is fitted under the cleanest conditions.

Pay attention to maximum cleanliness when connecting.

The TURBOVAC generates little noise or vibration. The TURBOVAC must not be influenced by vibration from other machinery.

Foreign objects which enter the pump via the high vacuum connection can cause serious damage to the rotor. An inlet screen must therefore be fitted.

The TURBOVAC is precision balanced and is generally operated without a resonance damper. To decouple extremely sensitive equipment and to prevent transfer of external vibrations to the pump a special resonance damper is available for mounting at the high-vacuum flange.

Mount the TURBOVAC with the high vacuum flange firmly onto the vacuum vessel. For this use a sufficient number of mounting bolts.

---

### NOTICE



The contact surfaces of pump housing, vacuum system and centering ring must be free of grease and dry so as to ensure adequate strength in case the rotor should seize.

## Fastening torques for the high vacuum flange connection

Connection	Pump	Number	Fastening torque
Clamps ISO-K	TURBOVAC SL 80 (H)	4x M10	20 Nm
Clamps ISO-K	TURBOVAC 350/450 i	6x M10	20 Nm
Bolts for collar flange ISO-K	TURBOVAC SL 80 (H)	4x M8	20 Nm
Bolts for collar flange ISO-K	TURBOVAC 350 i	8x M8	20 Nm
Bolts for collar flange ISO-K	TURBOVAC 450 i	8x M10	35 Nm
Bolts for CF flange	TURBOVAC SL 80 (H)	8x M8	15 Nm
Bolts for CF flange	TURBOVAC 350 i	16x M8	15 Nm
Bolts for CF flange	TURBOVAC 450 i	20x M8	15 Nm

### 3.4.1 Removing the TURBOVAC Pump from the Pump System

The TURBOVAC can operate in any position. It can also be dismantled from the pump system and only be fixed at the vacuum vessel. Please note in this case the regulations relating to the firm attachment of the TURBOVAC as detailed in the TURBOVAC Operating Instructions.

Disassembly: to remove the turbomolecular pump, loosen the six bolts at the mounting panel (see fig. 3.1).

Fit in the mounting panel to the pump system to a tightening torque of 5 Nm.

5 m long wiring between the removed pump and the TURBOLAB pump system is available. See Section Accessories.

# Installation

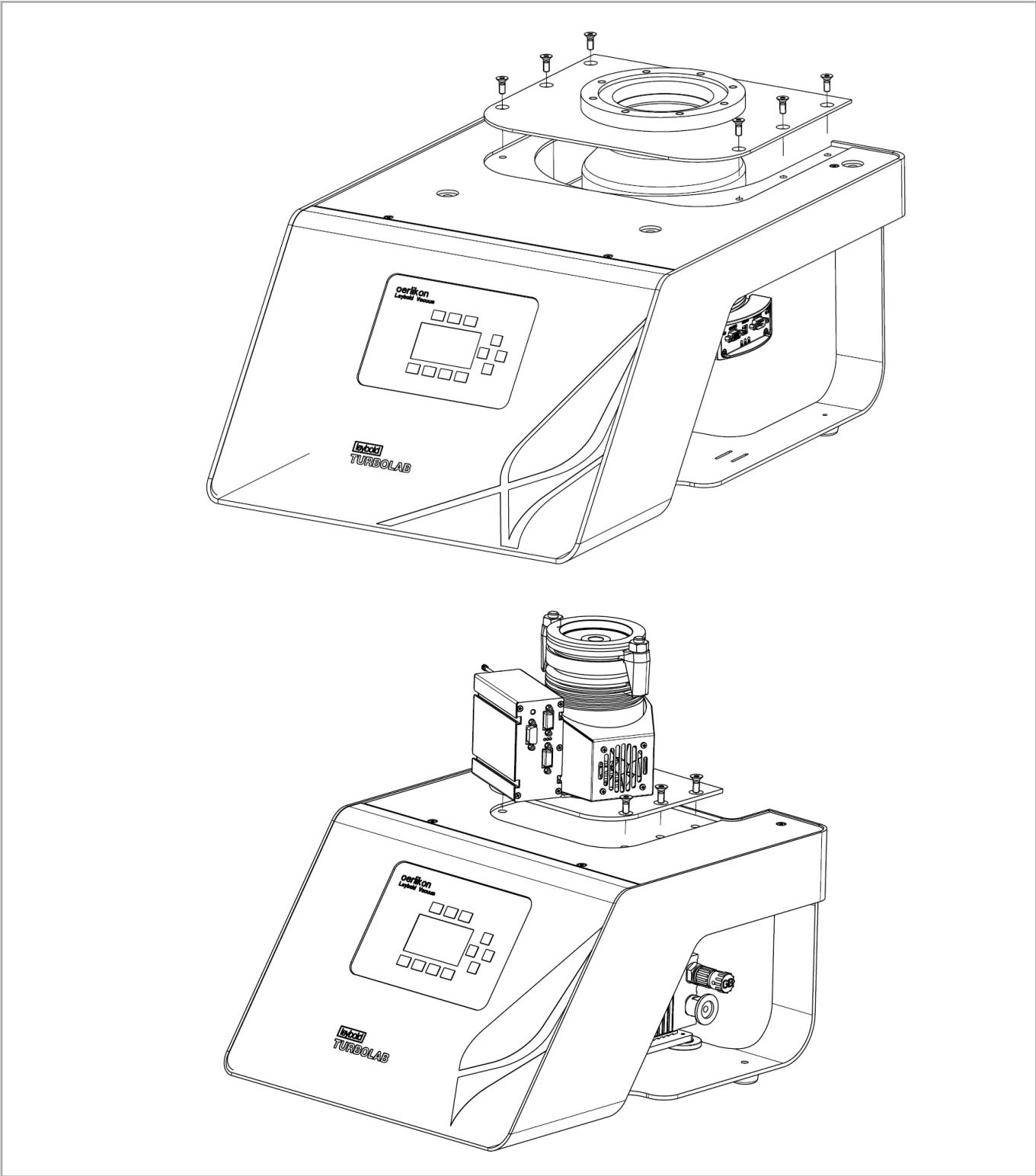

Fig. 3.1 Removing the mounting panel

### 3.5 Connecting the Exhaust Line

We urgently recommend to connect the exhaust of the backing pump to an exhaust line to prevent process gases or oil mists from being distributed within the room. This applies in particular when no exhaust filter has been connected. When not connecting an exhaust line, we recommend fitting of an exhaust filter in the case of oil-sealed vacuum pumps.

The cross-section of the exhaust line must at least match the inside diameter of the connections.

An exhaust line with a too narrow cross-section can cause overpressures within the backing pump.

The exhaust lines should be laid so that they drop down and away thereby preventing condensate from flowing back into the pumps.

If within the system toxic substances or gases are being used, then the operator will be responsible for ensuring that the corresponding safety precautions are introduced!

---

**DANGER**



### 3.6 Connect the Cooling

The backing pump is air-cooled; the TURBOVAC pump is convection, air or water cooled depending on the specific order.

Cooling of the pump depends on the required pumping power and the ambient temperature. When the pump is insufficiently cooled it will shut down.

High gas throughputs, cyclic operation or high ambient temperatures will necessitate air or water cooling.

The air cooler is connected to the accessories connection X205 (Fan).

#### **Air Cooling**

When installing air cooled pumps within a system ensure that sufficient quantities of fresh air are freely available.

The accessory connection is so pre-configured that the air cooler will always be running when the pump is running. To change this setting: Menu → Accessory → Fan.

# Installation

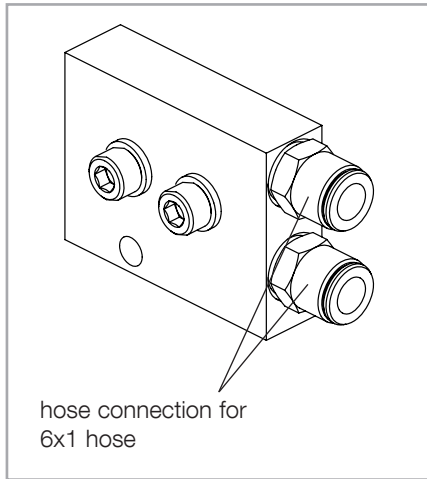

Fig. 3.2 Cooling water block of the TURBOVAC 350/450 i

## Water Cooling

Connect the cooling water hoses.

The hose connections may be unscrewed and removed, to make use of the integrated G 1/8"-threads.

### 3.6.1 Cooling Water

Adjust the cooling water temperature so that the formation of condensate is avoided. With pump downtimes the cooling water has to be turned off.

When switching the cooling water supply on and off by means of an electrically actuated valve, connect the valve so that it will be switched on and off together with the pump.

The cooling water pressure must not exceed 6 bar.

In order to ensure long trouble-free operation the cooling water must not contain any oils, greases and suspended solids. Moreover, we recommend compliance with the following limit values:

Appearance	Clear, free of oils and greases
Suspended matter	< 250 mg/l
Particle size	< 150 µm
Electrical conductivity	< 700 µS/cm
pH value	7.0 to 9.0
Total hardness (total alkaline earths)	< 8 °dH
Aggressive carbon dioxide	None, not detectable
Chloride	< 100 mg/l
Sulphates	< 150 mg/l
Nitrate	≤ 50 mg/l
Iron	< 0.2 mg/l
Manganese	< 0.1 mg/l
Ammonium	< 1.0 mg/l
Free chlorine	< 0.2 mg/l

8 °dH (degrees German hardness) = 1.4mmol/l  
= 10 °e (degrees English hardness)  
= 14 °f (degrees French hardness)

If there is the danger of frost, you may use a water glycol mixture of up to 30 %.

DS water can be used for cooling the pump, if the pH value corresponds to the range indicated above.



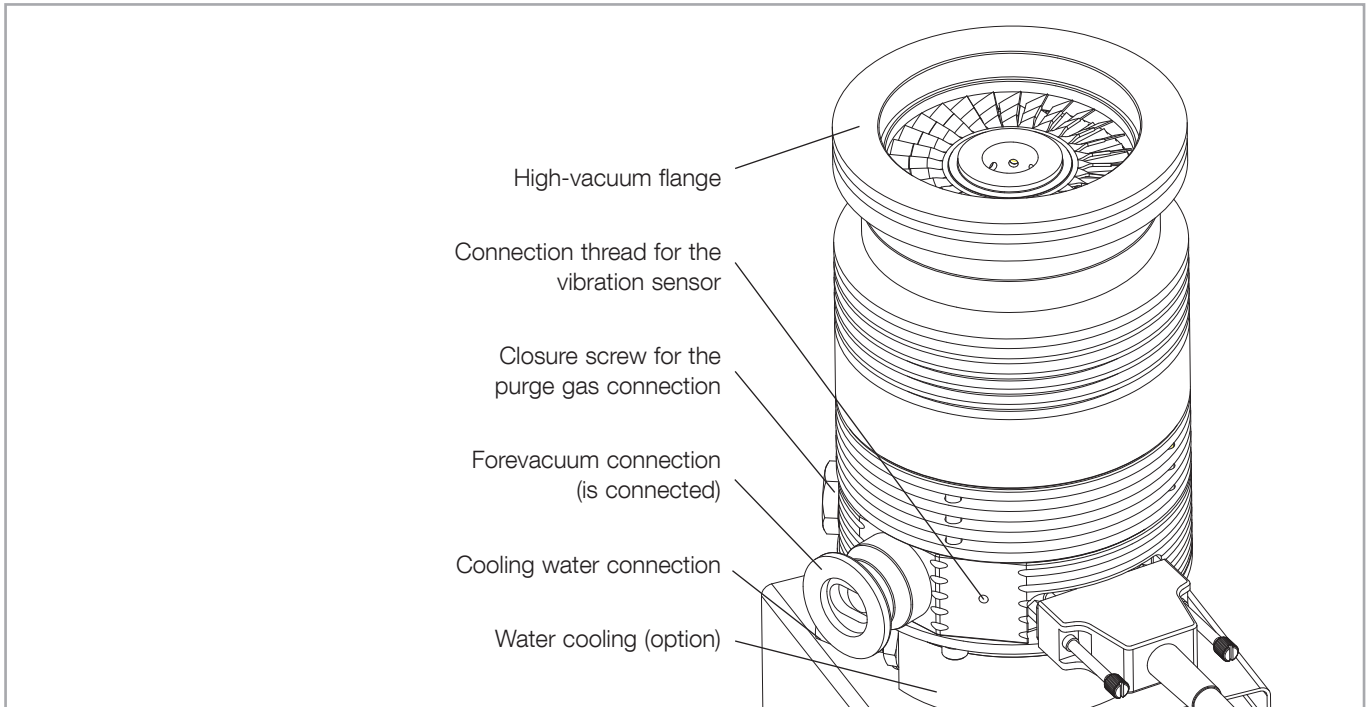

Fig. 3.3 Connections at the TURBOVAC SL 80

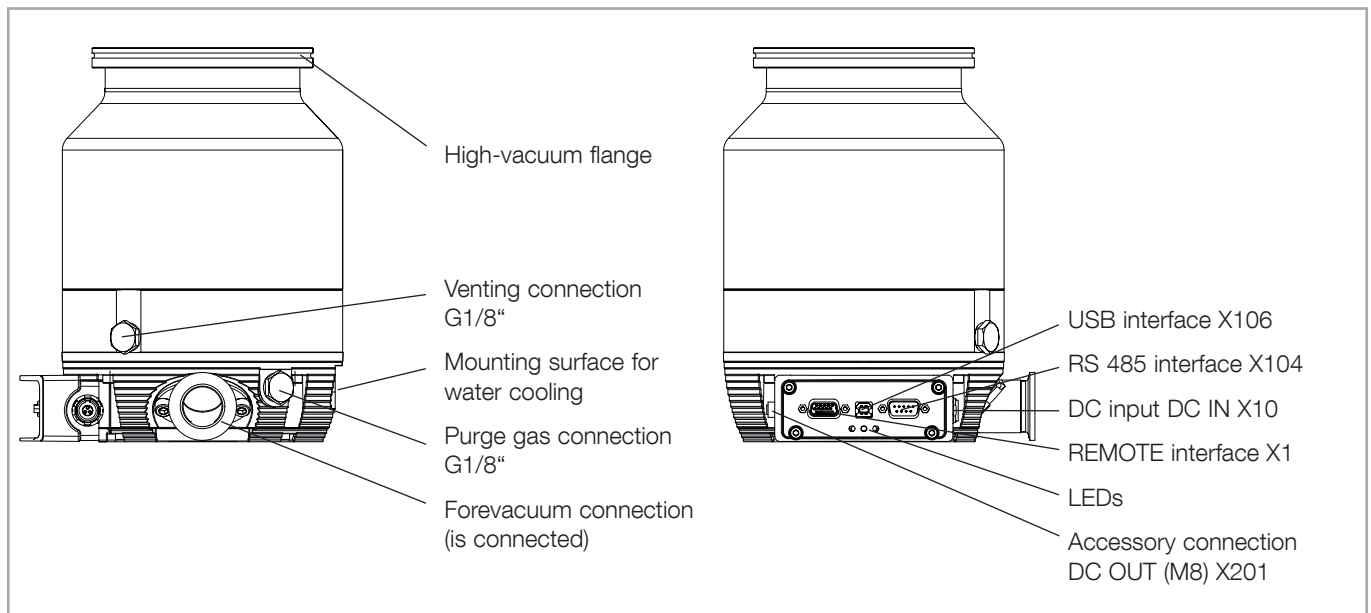

Fig. 3.4 Connections at the TURBOVAC 350/450 i

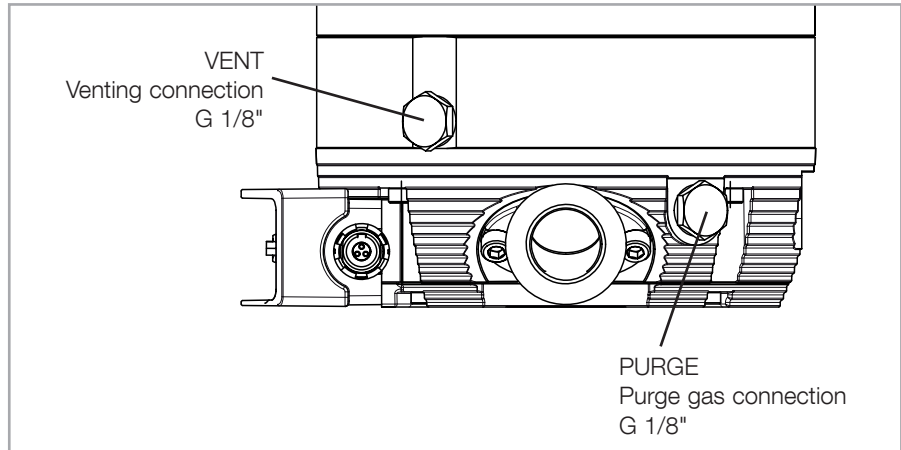

Fig. 3.5 Venting and purge gas connections

### 3.7 Connect a Power Failure Venting Valve or a Venting Valve

The power failure venting valve (normally open) or venting valve (normally closed, vents at stop command) vents the pump and the forevacuum line when the pump is switched off and thus keeps oil vapor from diffusing back from the forevacuum line. A choke nozzle in the vent port ensures that the pump is not vented too fast.

The max. permissible pressure in the pump must not exceed 1.4 bar (abs.).

Unscrew and remove the locking screw and the gasket from the venting connection of the TURBOVAC.

Screw in the venting valve and the gasket into the vent connection, then plug in the corresponding control cable into the X203 accessories connection on the TURBOLAB. The accessory connection is pre-configured for the vent valve operation. The vent valve will be triggered depending on the frequency of the TURBOVAC by default. If you have connected a power failure venting valve (normally open) you must change the operation output of X203; Menu → Accessory → Vent → change the operation to Power failure vent (via the TPU interface); If the pump station loses power then the vent valve will open.

For an overview of the connections, see fig. 3.7 and 3.8.

If applicable connect the venting gas supply at the valve's inlet (G1/8").

To change the venting valve function code go to Menu → Accessory → Vent (via the TPU interface).

---

#### WARNING



The pressure in the pump must not exceed atmospheric pressure. Observe Safety Information 0.1.2 to 0.1.5.

---

#### NOTICE



Connect a purge gas or venting valve to the correct flange. Confusing the venting and purge gas flange can cause shock venting of the pump.

---

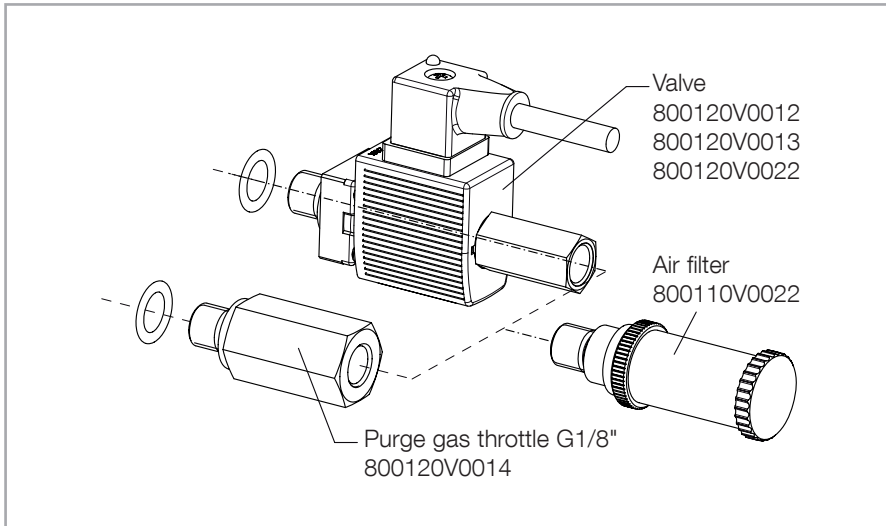

Fig. 3.6 Fitting valve

### 3.8 Connect Purge Gas

When having to decide which gases need or not need to be pumped with purge gas we are available to provide assistance.

Refer to Section 4.1 for suited gases.

Consider the additional purge gas flow when selecting a suitable backing pump.

We recommend a purge gas flow of 0.4 mbar-l/s (24 sccm) with Nitrogen.

The pressure in the pump must not exceed atmospheric pressure.  
Observe Safety Information 0.1.2 to 0.1.5.

The purge gas is fed either through an activated valve or a manually operated throttle.

#### Purge gas connection with purge gas valve

Unscrew and remove the locking screw and the gasket from the purge gas connection of the TURBOVAC.

Screw in the purge gas valve and the gasket into the thread, then plug in the corresponding cable into the accessories connection X204. Thereafter change the function for the accessory connection to "Always On" or "Active at Start Command", as the default is always set to Off. To change the venting valve function code go to Menu → Accessory → Purge (via the TPU interface).

Connect the purge gas supply at the valve's inlet (G1/8").

#### Purge gas connection with purge gas throttle

Unscrew and remove the locking screw and the gasket from the purge gas connection of the pump.

Then screw in the throttle and the gasket into the thread.

---

#### WARNING



# Installation

## 3.9 Connect a Flange Heater

For TURBOVACs with CF flange

If pressures in the range of  $10^{-8}$  mbar or below are to be developed, the vacuum chamber and the components installed therein will have to be baked out. In addition, the TURBOVAC can be baked out using the flange heater provided for this purpose.

Connect the flange heater to the TURBOLAB at X208. It can be switched on manually at the switch above.

Information on baking out is also given in Section 4.7.

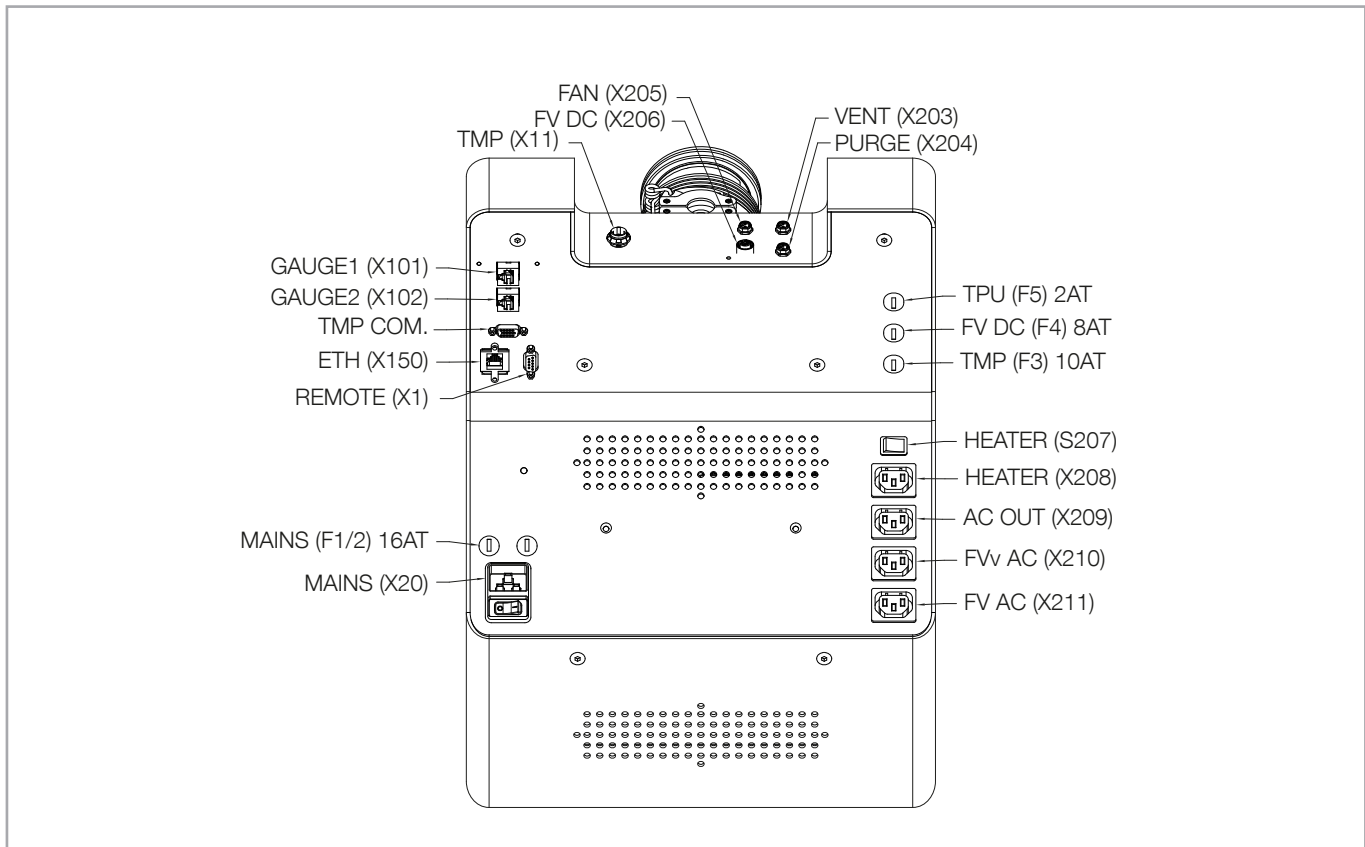

Fig. 3.7 Electric connections, fuses and switches (bottom view onto TURBOLAB 80 and 80 Cart)

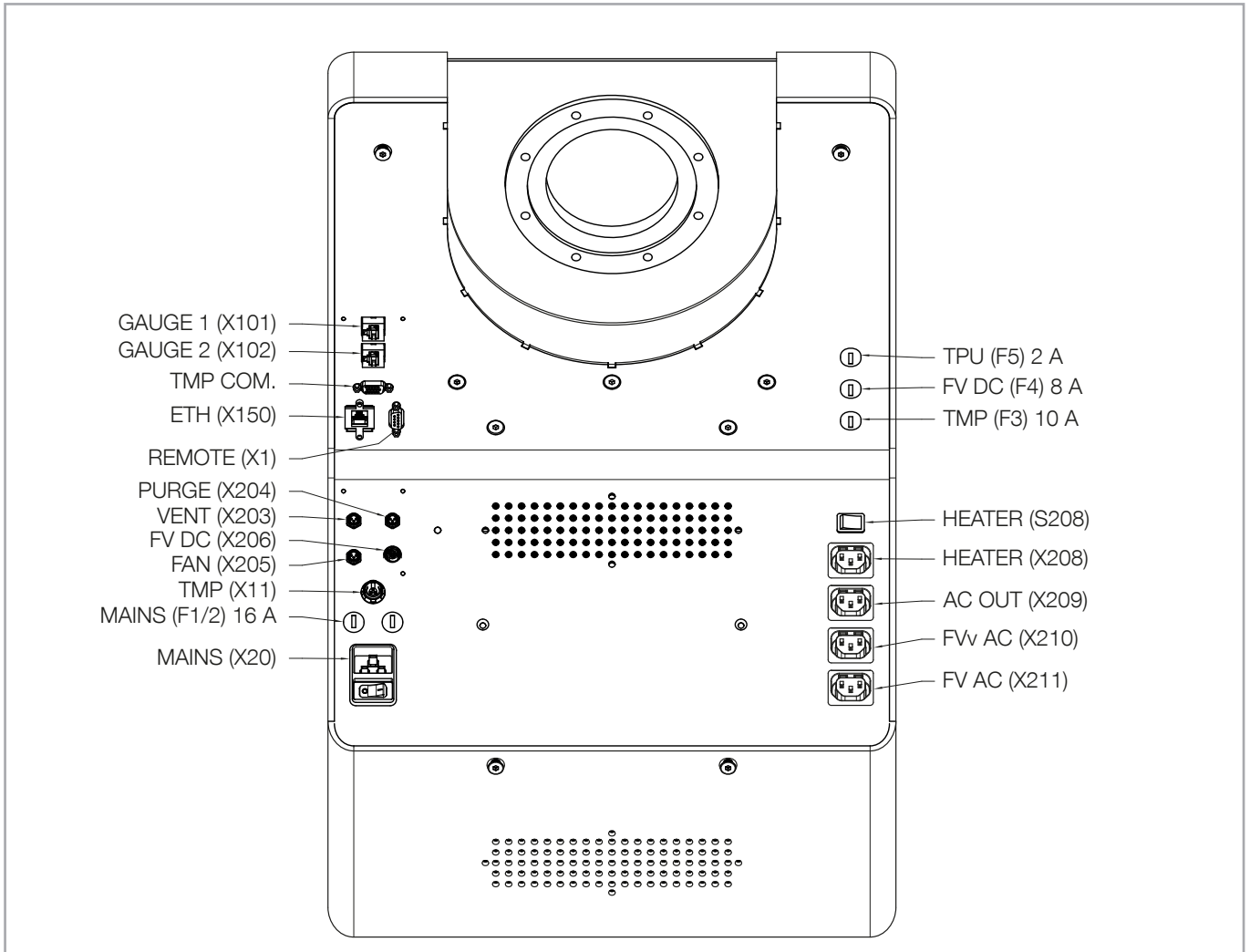

Fig. 3.8 Electric connections, fuses and switches (bottom view onto TURBOLAB 350/450 und 350/450 Cart)

### 3.10 Connect a Gauge

Two Gauges can be connected to the TURBOLAB. Three gauge types are supported by the TURBOLAB (PTR90, TTR91, TTR101). Use gauge ports X101 & X102 for connecting gauges.

### 3.11 Connect a PC/Mobile Device

Use the RJ-45 Comm. port to connect a PC and use the web server interface.

In order to be able to operate the pump system through the Ethernet interface, the control hierarchy in the display must be changed to X1 Ethernet. Otherwise, it will only be possible to read parameters.

---

**WARNING**



## 3.12 Electrical Connection

The pump system shall be operated only at the line voltage specified on the data plate.

Do not open the switchbox and do not remove any covers from the electrical equipment. Do not disconnect any earth connections!

Unplug any connectors only when the mains voltage is switched off **and** the pump does no longer turn. (LEDs are off)

---

The shockproof sockets to which the pump system is connected, must be equipped with a suitable overcurrent circuit breaker. After having provided the electrical connection, check to ensure that the overcurrent circuit breaker is operating properly.

A mains power disconnecting device must be easily accessible and located between 0.6 meters and 1.9 meters above the access level. We recommend an upper limit of 1.7 meters.

Plug the mains cable into the mains socket.

For an overview of the connections, see fig. 3.7 and 3.8.

When connecting accessories, use only original Leybold oil filters and gas admission filters since the design of these components is such that proper earthing is ensured.

## 4 Operation

### 4.1 Media Compatibility / Purge Gas

The pump system is suitable for pumping air and clean gases.

If reactive gases in low concentrations must be pumped operate the pumps with purge gas.

We would be glad to consult with you as regards the media which can safely be handled with this unit.

Install a micropore filter when pumping media which contains dust.

Suited for venting or purging are all gases,

- which will not cause corrosion or pitting in aluminium and steel and
- which in connection with process deposits in the pump will not cause corrosion or sticking.

For venting and as the purge gas we recommend inert gases like nitrogen or argon. The temperature of these gases should be between 5 °C and 80 °C, max. relative humidity should not exceed 10 ppm.

The gas must be clean.

In individual cases and after consultation also dry, filtered, oil-free air or filtered ambient air may be used (filter mesh < 1µm).

Change the filters after some time, at least annually.

### 4.2 Start-up

The TURBOVAC offers the feature of gently running in pumps which have been out of operation for more than 6 and less than 12 months. This gentle run-up also makes sense after a bearing change.

To do so, set parameter 119 at the TPU in the parameter menu (Menu → Parameter) to 1. The red LED at the pump will flash during this procedure. Parameter 119 remains set after the run and needs to be set manually to 0.

Turbomolecular pumps which were not operated for a period of over 12 months should be returned to us. For more information on this please contact your local sales partner.

## 4.3 Interfaces

Designation	Description
X101 & X102 - Gauge 1 & Gauge 2	At the TURBOLAB two vacuum gauge heads can be connected. For this, two of the following six types can be used: PTR 90, PTR 91N, TTR 91, TTR 91N, TTR101, TTR 101N.
TMP Com.	RS 485 – communication to the turbomolecular pump (Start/Stop, read/write parameter).
X150 ETH	Connect a computer to the RJ-45 COM interface and use the web server interface. (Software updating, data logging etc.).
X1 Remote	24VDC input/output + analogue out - for connecting a PLC  In order to be able to operate the pump system through the interface, the control hierarchy in the display must be changed to X1 Remote..
X204 Purge	Connection for purge gas valve (default: always off).
X203 Vent	Connection for venting valve (default: active, frequency dependent after Stop command).
X206 FC	Connection for 24VDC backing pump (default: active for start command).
X205 Fan	Connection for fan (default: active for start command).
X11 TMP	Power supply for 24VDC turbomolecular pump
F1/2	110/230 VAC inlet fuse.
F3	24 VDC fuse for turbomolecular pump.
F4	24 VDC fuse for backing pump.
F5	24 VDC fuse for display (TPU)
X208	110/230 VAC power supply for heating tape (switched through S208).
X209 	110/230 VAC power supply (constantly on) (1 A maximum).
X210	110/230VAC power supply for forevacuum valve (switched via internal relay) (default active for start command).
X211	110/230VAC power supply for backing pump (switched via internal relay) (default: active for start command).
X20	110-230VAC power supply for TURBOLAB (plus On/Off switch).



## REMOTE X1

15-pole Sub-D female  
High Density

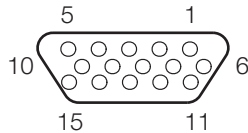

Maintain pin 6 Signal GND and pin 13 Analog GND separate so as to avoid equalisation currents.

Pin	Name	Description
1	Error relay	(com)
2	Error relay	(n.c.)
3	Normal operation relay	(n.o.)
4	Normal operation relay	(com)
5	Normal operation relay	(n.c.)
6	Signal GND	
7	High level output	24 V, 100 mA, Tolerance acc. to device supply voltage
8	Start input (High) Reset input (Low)	High > 10 V ± 0,5 V Low < 7.5 V ± 0,5 V
9	Error relay	(n.o.)
10	Standby input	High > 10 V ± 0.5 V Low < 7.5 V ± 0.5 V
11	Cooling/Venting valve input (Low)	High > 10 V ± 0.5 V Low < 7.5 V ± 0.5 V
12	Analog output (Default: Frequency)	0 ... 10 V, 2 mA
13	Analog GND	
14	Warning relay	(n.o.)
15	Warning relay	(com)
Shield	Connected with pump housing	

### Start/Stop input

0V = STOP/Error reset  
24 V = START

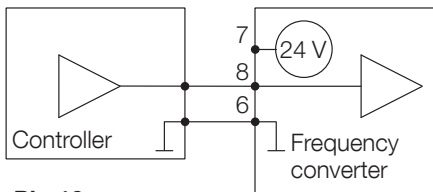

#### Pin 10

0 V = no Standby operation  
24 V = Standby operation

#### Pin 11

0 V = no function  
24 V = Cooling or valve is activated

Contact open = STOP/Error reset  
Contact closed = START

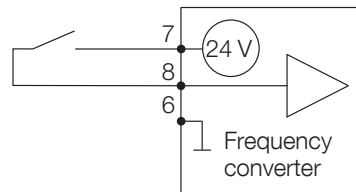

#### Pin 10

Contact open: no Standby operation  
Contact closed: Standby operation

#### Pin 11

Contact open: no function  
Contact closed: Cooling or valve is activated

### Analog output

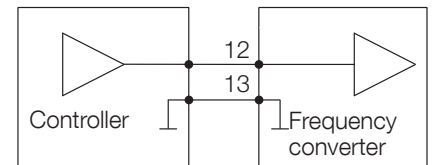

### Relay

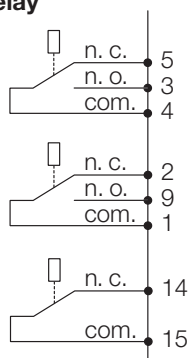

#### Normal operation relay

4 and 5 connected (normal position) Run-down, run-up, stop  
4 and 3 connected Normal operation

#### Error relay

1 and 2 connected (normal position) No error  
1 and 9 connected Error

#### Warning relay

14 and 15 connected (normal position) No warning  
14 and 15 open Warning

Fig. 4.1 REMOTE interface X1

# Operation

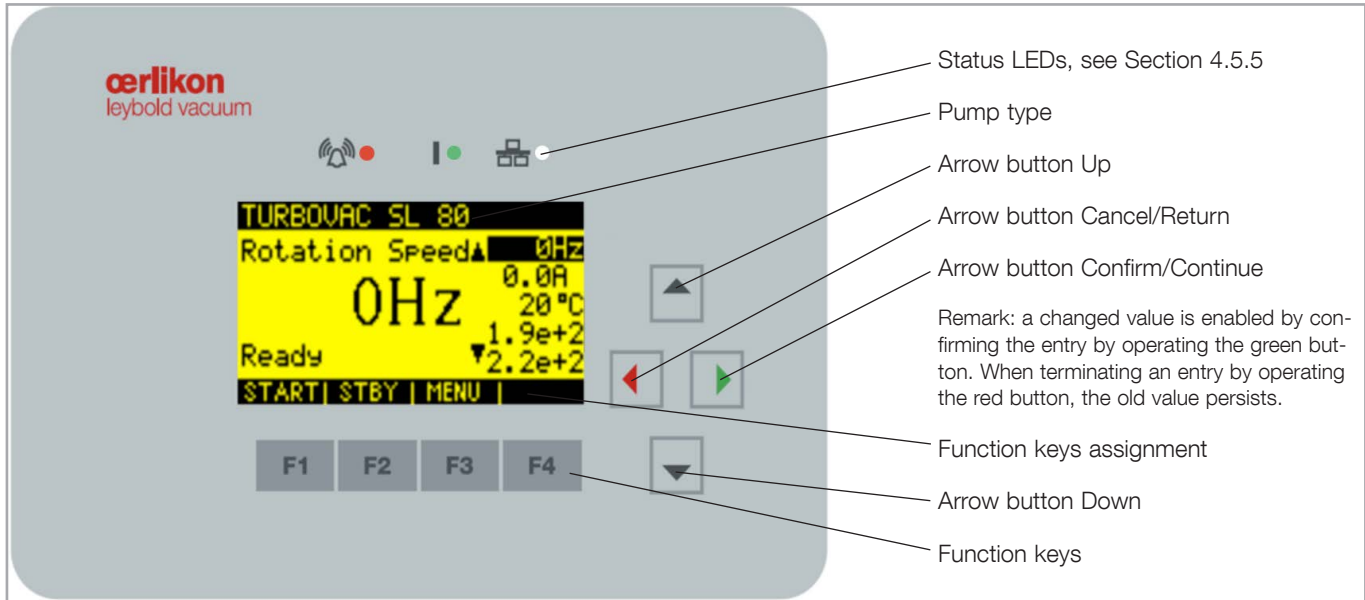

Fig. 4.2 TPU display with keys

## 4.4 Switching On

Check the oil level of the TRIVAC or SOGEVAC.

If condensible gases and vapors are to be pumped, open the gas ballast valve of the backing pump.

Operate the pump system at the TPU with the help of the function keys. You will find an overview over the menu on the following pages.

For water cooled TURBOVACs open the cooling water supply.

Avoid causing jolts or vibration when operating the pump system.

## 4.5 Operation

### 4.5.1 Menu

Main Screen				
Turbopump speed	Turbopump motor current	Turbopump bearing temperature	Gauge 1	Gauge 2





By operating the operator buttons Up/Down you may display one of the values on the left-hand side on the main screen.

Error log				
Error log of the turbopump	Error history of the turbopump	Error log details		



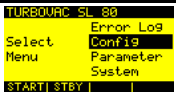
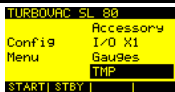

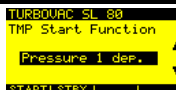
Accessory menu and X1					Description
					Selection for the venting valve output function X203.
Configuration menu	Configure accessories	Venting valve	Venting valve: Change configuration	Venting output function: frequency dependant	
					Selection for the purge gas valve output function X204
		Purge gas valve	Purge gas valve: Change configuration	Purge gas valve output function: always off	
					Selection for the fan gas valve output function X205.
		Fan	Fan: Change configuration	Fan output function: fan is running when the pump turns	
					Selection for the backing pump output function X206. Corresponds with X210 & X211
		Backing pump (Forevacuum pump) and safety valve	Backing pump: Change configuration	Backing pump output function: starts with start command	
					Selection for the relay normal operation on the X1 interface
	Configure X1	Relay normal operation	Relay normal operation: Change configuration	Relay function: Relay switches at normal operation	

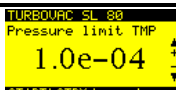
The limit values may be changed in the respective configuration menu for the accessory output. Shown here are the default settings. The individual functions for the accessory outputs are described in one of the following chapters. To simplify the diagram, setting up of the relay errors, warnings and the analogue output is not described here.

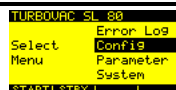
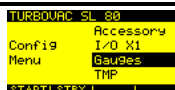
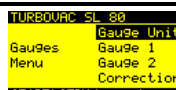
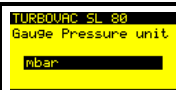
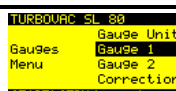
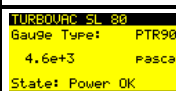
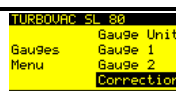
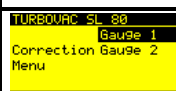
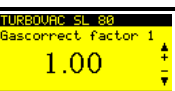

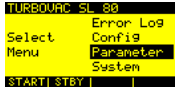

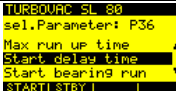

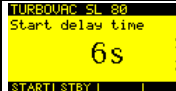
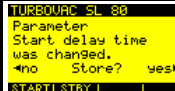

# Operation

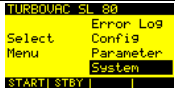
Turbopump menu				Description
 Configuration menu	 Configure turbopump	 Configure turbopump function	 The turbopump starts at start command	The turbomolecular pump starts with the start command. The value entered under "Press. Val." is not used here.
			 The turbopump starts pressure dependant	
		 Configure pressure value	 Change value	Setting up the limit value for pressure dependent switching on of the turbomolecular pump.
Further functions for the turbomolecular pump are described in one of the following chapters.				

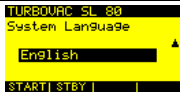
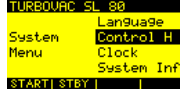
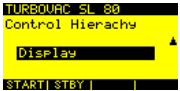
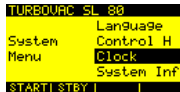
Gauges menu				Description
 Configuration menu	 Configure gauges	 Setting the unit		You may change between mbar, Torr and Pascal. The setting is carried over to the main screen.
		 Gauge connection X101	 Detailed information for the gauge	Display of type, measured value, unit of measurement, status. Through "Off" (F3) the vacuum gauge head may be deenergised.
		 Gas correction factor	 Setting the Gas correction factor for the gauge at X101	The gas correction factor must be set up according to the information given in the Operating Instructions for the respective vacuum gauge head.
			 Change value	

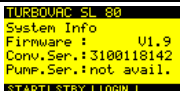
Parameter menu					Description
 <p>Parameter menu</p>	 <p>Select parameter</p>				
	 <p>Select parameter</p>	 <p>Change parameter</p>	 <p>Wert ist geändert, aber noch nicht aktiv</p>	 <p>Abfrage dauerhaft Speichern</p>	<p>When changing the parameter it will flash and be shown underlined.</p> <p>Thereafter you are queried whether the parameter shall be saved permanently. When confirming this message, the changed value is maintained even after power cycling. When not saving the value, the old value will be active again after a power cycling.</p>
<p>Saving can take several seconds. During this time, the pump must not be disconnected from its power supply. Initiating the saving process will cause all preceding changes to be saved.</p>					

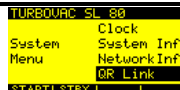
# Operation

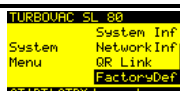
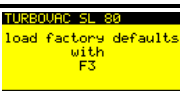
System menu			Description		
					
	Language	Change language			
					
	Control hierarchy	Change control hierarchy			Here you can define from where the pump can be operated (display, X1, Ethernet)
					
	Clock	Setting the time			Setting the system time and date
					
	System information	Display system information			Display firmware version, pump serial number
					
	Network information	Display the current IP address, subnet mask and DHCP status			Display the IP address for activation of the webserver, DHCP setting and basic IP address settings
					
	QR Link	Display the QR link			For opening the webserver
					
	Factory defaults	F3, reset to factory defaults			Resets all parameter changes to factory defaults. Can only be run with the pump at standstill. The pump parameters will only be reset provided after having initiated this function a voltage reset for the turbo pump is initiated. For this, switch the pump system with the turbomolecular pump at standstill off and then on again.

## 4.5.2 Function Codes of the Accessory Connections

The start command always relates to the start command for the turbomolecular pump.

In case of a setup switch-on delay for the turbomolecular pump start, the backing pump is switched on without taking this switch-on delay into account (in case of a corresponding function code).

The respective accessory output can be configured through the submenu "Accessories" indicated on the display or by the web server.

### Function X205 Fan

Function code	Function	
0	Always off	The output is always disabled
19	Always on	The output is always enabled
28	Pump is turning	<b>Default:</b> The output is set when the pump is turning
29	frequency dependent	The output is set when the frequency exceeds the upper limit. When the frequency drops below the lower limit, the output is reset again. adjustable parameter: upper limit adjustable parameter: lower limit
30	bearing temperature dependent	The output is set when the bearing temperature exceeds the upper limit. When the bearing temperature drops below the lower limit, the output is reset again. adjustable parameter: upper limit adjustable parameter: lower limit

#### State diagram frequency dependent/bearing temperature dependent (29, 30)

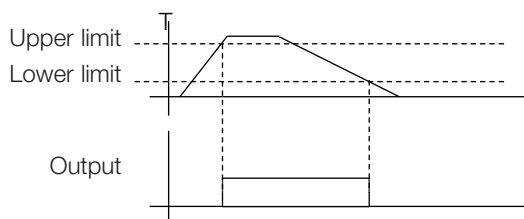

When upper limit = lower limit is set up then the output switches as soon as the limit is exceeded and it switches off again when the value drops below the limit.

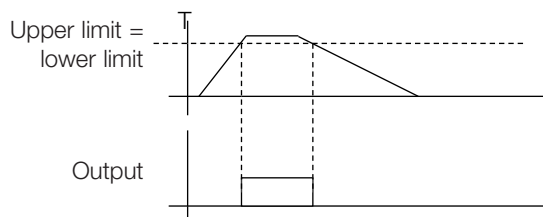

# Operation

## Function X204 Purge gas valve

---

### Function code

### Function

0	Always off	<b>Default:</b> The output is always disabled
19	Always on	The output is always enabled
33	Start command	The output is active when starting the turbomolecular pump. adjustable parameter: Switch-on delay time adjustable parameter: Switch-off delay time

---

### State diagram Start command 33

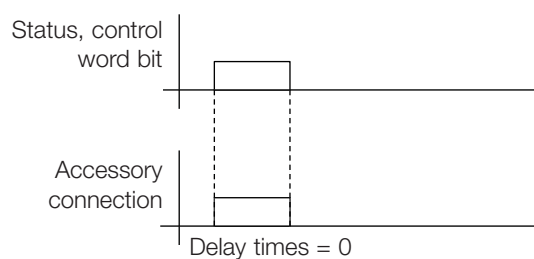

Additionally, a switch-on/switch-off delay time can be set up. The delay time is entered in milliseconds.

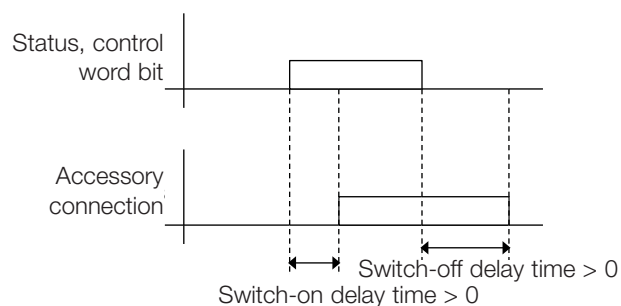



## Function X203 Venting valve

Function code	Function	
0	Always off	The output is always disabled
19	Always on	The output is always enabled
36	frequency dependent	<b>Default:</b> the output is set when the start command is not set and the frequency is within the two limits. When the lower limit is tripped, the output is reset. adjustable parameter: upper limit adjustable parameter: lower limit
25	power failure venting	Within these limits, the relay is switched off in the event of a mains power failure. adjustable parameter: upper limit adjustable parameter: lower limit

**State diagram frequency dependent 36**

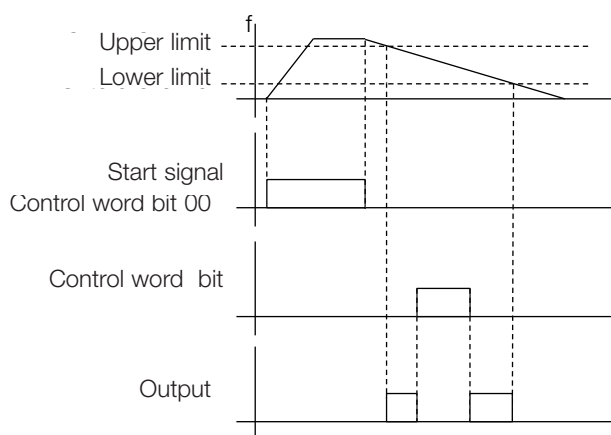

**State diagram power failure venting (25)**

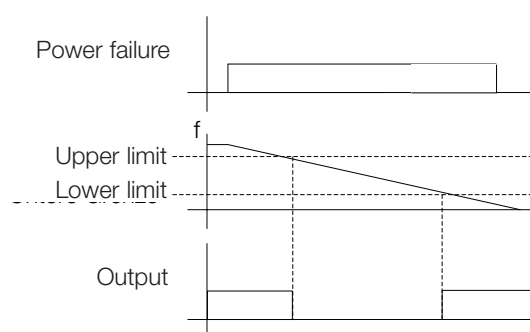

# Operation

## Functions 24VDC Output backing pump (X206, X210, X211)

Function code	Function	
0	Always off	The output is always disabled
19	Always on	The output is always enabled
34	Start command	<b>Default:</b> the output is active upon Start. adjustable parameter: Switch-on delay time adjustable parameter: Switch-off delay time

### State diagram Start command 34

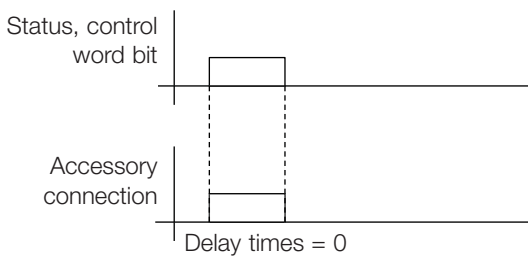

Additionally, a switch-on/switch-off delay time can be set up. The delay time is entered in milliseconds.

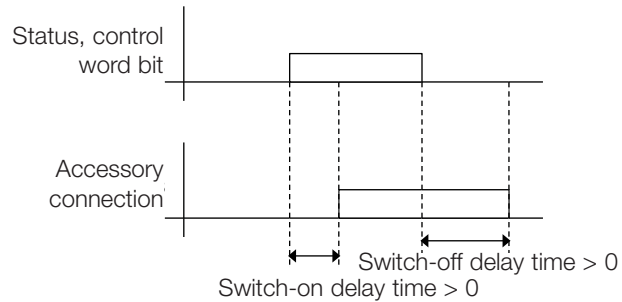

35	current dependent	<p>Current dependent switching on of the backing pump.</p> <ol style="list-style-type: none"> <li>1. When the pump is running up to its nominal speed, the output is set until the lower current limit is tripped.</li> <li>2. The output is set when the start command is active, the pump is running in its normal operating mode and the current has exceeded the upper limit. When the lower limit is tripped, then the output is reset again.</li> <li>3. When revoking the start signal, the output is reset.</li> </ol> <p>adjustable parameter: upper limit (unit 0.1 A) adjustable parameter: lower limit (unit 0.1 A)</p>
----	-------------------	---

### State diagram current dependent 35

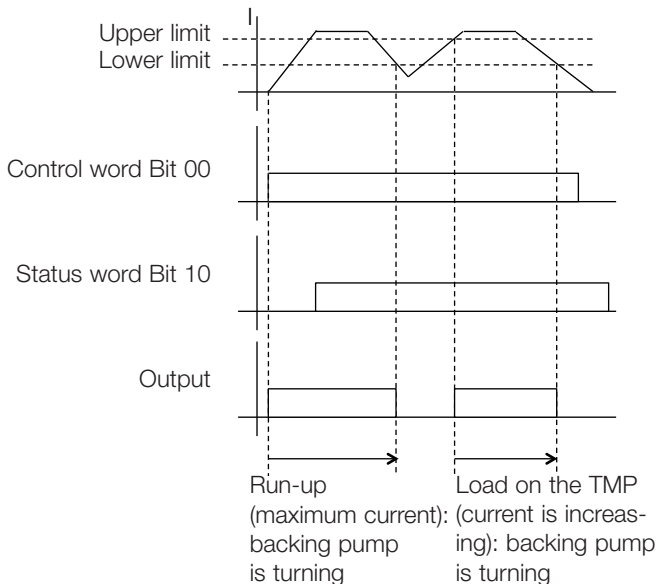

## Functions 24VDC Output backing pump (X206, X210, X211)

Function code	Function
35	<p>pressure dependent</p> <p>Functions for starting the turbomolecular pump</p> <ul style="list-style-type: none"> <li>■ Backing pump off</li> <li>■ Backing pump starts with Start signal</li> <li>■ Backing pump starts depending on the pressure (measured value from vacuum gauge head at X101)</li> <li>■ Backing pump starts depending on the pressure (measured value from vacuum gauge head at X102)</li> </ul> <p>When the start command is present, the backing pump starts. When the turbomolecular pump has entered its normal operating mode, and if the pressure drops below the preset pressure level, then the backing pump will stop.</p> <p>Adjustable parameter: frequency limit high Adjustable parameter: frequency limit low</p> <p>When the pressure exceeds the pressure level then the backing pump will start and will stop again when the turbomolecular pump has entered normal operation and the pressure has dropped below the pressure threshold.</p> <p>In case of a Stop command, both backing pump and turbomolecular pump will stop.</p> <p>This function is suited for triggering on the high vacuum pressure. The backing pump will only be operated when necessary.</p> <p>This function will intervene only provided the turbomolecular pump is in its normal operating mode.</p>

**State diagram pressure dependent (35)**

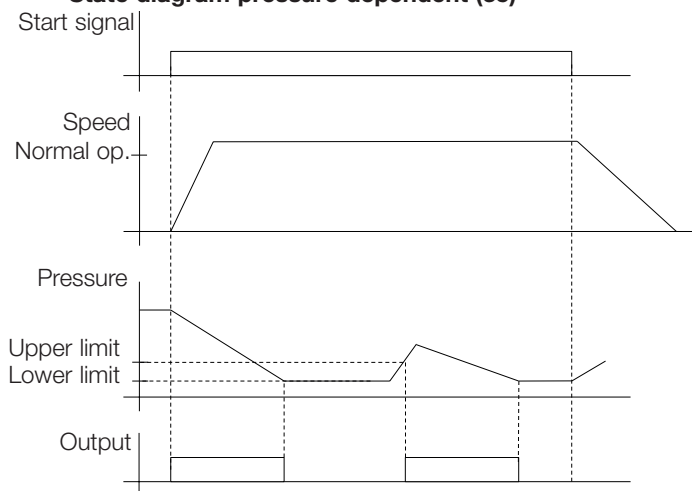

# Operation

## Function pressure dependent switch-on of the turbo pump

---

When enabling this function, parameter P 625 will contain the dependency  
**(default = 1)**

- Turbomolecular pump off
- Turbomolecular pump starts with Start signal
- Turbomolecular pump starts depending on the pressure (measured value from gauge head at X101)
- Turbomolecular pump starts depending on the pressure (measured value from gauge head at X102)

When this function is not enabled, then P 625 will not be taken into account.

When this function has been enabled, the pump will behave as shown in the diagram: the pump starts when a start command is present and the pressure has dropped below the limit.

Adjustable parameter: frequency limit

Revoking the start command stops the turbomolecular pump.

This function is suited for triggering on the forevacuum pressure. The turbomolecular pump will only start, provided, a certain pressure level has been attained by the forevacuum pump in the forevacuum line.

---

### Function pressure dependent switch-on

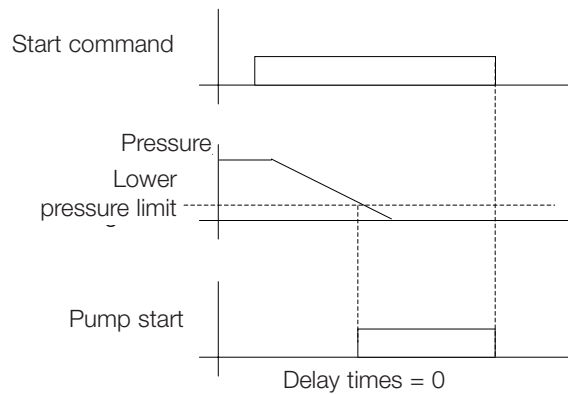

## 4.5.3 Relay Functions

### Relay Normal Operation

Function code	Function	
0	Frequency dependent	<b>Default:</b> relay switches as soon as the setup normal operating threshold is reached.
3	Bearing temperature dependent (P122)	Adjustable parameter: temperature limit
4	Power failure venting (P247/P248)	<p>Within these limits, the relay is switched in the event of a power failure.</p> <p>Adjustable parameter: frequency limit high Adjustable parameter: frequency limit low</p> <p>Remark: this is a normally open valve, i.e. when the voltage is switched off, the output goes to 0; when the pump running the output is 1.</p> <p>State diagram power failure venting, see Section above.</p>
5	Pump at standstill ( $f < 3$ )	Relay switches, when the pump is turning below 3 Hz.
6	Start command	Relay switches, when the start command is initiated.
7	Ready for switching on	Relay switches, when the pump is ready

### Error Relay

Function code	Function	
1	Active at error	<b>Default</b>
2	Inactive at error	

### Warning Relay

Function code	Function	
1	Active at warning	<b>Default</b>
2	Inactive at warning	

# Operation

















## 4.5.4 Parameter list

No.	Designation	Description
1	Device type	136 = Turbo.Drive 400 180 = TURBOVAC 350/450 i 181 = TURBOVAC 350/450 i with optional interface 182 = TURBOVAC 350/450 iX 190 = TURBOVAC 80/200 i 191 = TURBOVAC 80/200 with optional interface 192 = TURBOVAC 80/200 iX
2	Software version communication electronics x.yy.zz	
3	Actual frequency	Actual rotor frequency
4	Actual intermediate circuit voltage	
5	Actual motor current	
6	Actual drive input power	
7	Actual motor temperature	
8	Save data command	A write command with any value saves temporary data into nonvolatile memory. How to proceed: Write a value >0 (S 16) to P 8. -> Parameter changes are saved in the converter. A write command with any number will cause the data to be taken over.
11	Actual converter temperature	
16	Motor temperature warning threshold	Exceeding the motor temperature warning threshold results in a warning.
17	Nominal motor current	Maximum permissible motor current
18	Nominal frequency	Highest permissible frequency
19	Minimum nominal frequency	Lowest permissible nominal frequency
20	Minimum frequency level	When the pump is accelerating this frequency must be reached within the maximum passing time (P183). At the end of run-up: Switch-off threshold at overload.
21	Motor current threshold	After attaining normal operation and when this threshold is exceeded a „high load error“ will occur after a certain period of time has elapsed.
23	Pump type/Rotor type	not used
24	Setpoint frequency	Setpoint of the rotor frequency
25	Frequency dependent normal operation threshold	Setpoint of the frequency dependent normal operation level
32	Max. Run-up time	Max. permissible time during which the pump must attain the normal operation threshold (P24*P25) with the start signal present.
36	Start delay time	Delays the start of the pump to allow lead-time for the fore vacuum pump for example. Only active when the pump is under x Hz.
119 [0]	Index 0: Start bearing run in function	0 = converter starts pump normally 1 = converter starts with phase 1 2 = converter starts with phase 2 4 = converter starts with phase 3
119 [1]	Index 1: Status bearing run in function	1 = 1st phase active 2 = 2nd phase active 4 = 3rd phase active 8 = 4th phase active

No.	Designation	Description
125	Actual bearing temp	Calculated temperature of the bearing.
126	Bearing temp warning threshold	Exceeding the bearing temperature warning threshold results in a warning.
128	Motor temp lower warning threshold	Falling below the motor temperature lower warning threshold results in a warning.
131	Motor temp lower error threshold	Falling below the motor temperature lower error threshold results in an error message.
132	Bearing temp error threshold	Exceeding the bearing temperature error threshold results in an error message.
133	Motor temp error threshold	Exceeding the motor temperature error threshold results in an error message.
140	Intermediate circuit current	Mean value measurement of the intermediate circuit current. Corresponds to the current consumption of the frequency converter.
150	Standby Frequency	Standby operation frequency setpoint
171 [0..253]	Error Code Memory	Indexed parameter for storing the most recent 40 error codes. The individual error memory entries are accessed via this parameter with additional index number. The last error code is accessed with index 0 and the oldest with index 39.
174 [0..253]	Hz @ Time of Error	Access analogously as for parameter 171
176 [0..253]	Hours @ Time of Error	Access analogously as for parameter 171
184	Converter Operating Hours	Counts the operating hours of the converter during active pump operation.
249	Generator mode	P249 = 0 : no return feeding in to the DC supply P249 = 1 : return feeding in to the DC supply Notice: take note of the maximum generator power of as otherwise the electronics may suffer damage.
312 [0..17]	Converter part number	Converter part number. One ASCII character per index.
315 [1..17]	Converter serial number	
355 [0..17]	Pump serial number	not used

# Operation

## 4.5.5 Monitoring of the Operation Conditions

LED	Symbol	LED Status	Display	Meaning
Red 		Off		No System Error
		Flashing		System Warning
		Steady		System Error
		Steady		Turbo Pump lost communication
Green 		Off		Pump not turning / no start command active
		Flashing 50 ms on, 500 ms off		Start delay > 0 (P36)
		Flashing slowly 1/s		Running up
		Flashing fast 3/s		Running down
		Steady		Normal Operation
White 		Steady		Ethernet Communication Active

## 4.6 Shut-down

Stop the pump system with the TPU using the function keys on the display.

### Venting

For oil-sealed backing pumps, vent the TURBOVAC before it comes to a stop; see Section 4.6.

When using TRIVAC pumps the built-in anti-suckback valve will close automatically, shutting off the forevacuum line. In forevacuum pumps without a vacuum retention valve, close the valve in the forevacuum line.

When the system is not operating, ensure that neither ambient air nor cleaning media can enter the pump.

If a failure occurs the turbomolecular pump will be shut down automatically. The red LED at the frequency converter lights up.

### Emergency shut down

In the case of an emergency shut down, the pump is switched off as described above. The rotor of the turbomolecular pump may be stopped faster by venting the pump.

Under vacuum conditions the pump may take up to one hour to run down, when venting to atmospheric pressure it may take up to one minute. During the time the pump is running down, the green LED will flash, indicating that the rotor has not yet arrived at standstill.

When shutting down by **switching off the power supply voltage**, there will be only enough power for the LEDs down to a speed of the pump of approximately 200 Hz. Thus the pump may still turn without a LED being on. For this reason, when switching off without venting, wait for approximately 15 minutes after the LEDs have turned off until the pump has arrived at standstill.



Unplug any connectors only when the mains voltage is switched off and the pump does no longer turn (the green LED is off).

---

**CAUTION**

---



## 4.7 Venting

Refer to Section 4.1 for suited gases.

### Venting Methods

There are different methods of venting the turbomolecular pump.

In the case processes requiring a purge gas, the pump must be vented via the **purge gas and venting valve** when shutting the pump down.

When additionally venting the vacuum chamber, the venting function of the purge gas and venting valve must be opened before opening the chamber valve. This will ensure the presence of a higher pressure in the area of the ball bearings compared to the remaining vacuum area. This will prevent particles, dust or aggressive gases from being forced through the bearings into the not yet vented motor chamber of the pump.

The TURBOVAC 350/450 i can be vented via the **venting connection** (VENT), by means of a venting valve, a power failure venting valve, or a venting screw.

Cautious venting of the pump is possible from the **high vacuum side**, since here the bearing forces will be lowest. When doing so, no free jet of gas must be allowed to form on the rotor so as to avoid exposing the rotor to additional forces.

When venting the pump through its **foreline connection**, neither oil nor particles may be entrained in the gas flow from the forevacuum side into the pump.

### Speed of the Pressure Rise

All turbomolecular pumps may be vented at full speed. However, the pressure must not increase faster than specified through the pressure rise curve.

The pump must be vented significantly slower when there is the risk of particles entering into the pump from the process. During venting, the flow must be of the laminar type in both the vacuum chamber and the turbomolecular pump.

The pump must not be vented to pressures above atmospheric pressure.

**Speed  
Pressure rise curve**

**Particles**

# Operation

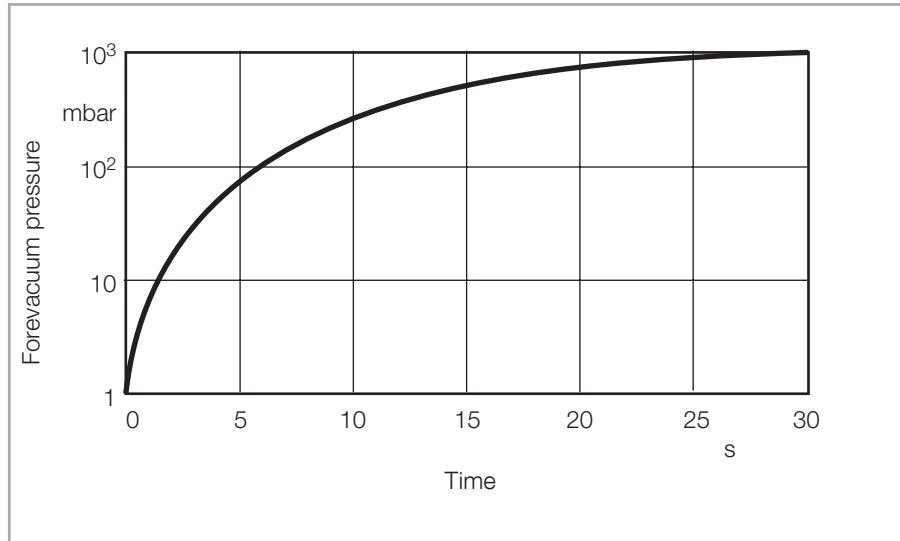

Fig. 4.3 Maximum rise in pressure

## 4.8 Bakeout

Only turbomolecular pumps with CF flanges may be baked out.

The backing pump and TURBOVAC must be in operation during bakeout.

Switch the flange heater on and off at the switch S208 at the TURBOLAB.

Protect the rotor against intensive, direct heat radiation. The temperature of the high vacuum flange must not exceed 100 °C. When baking out at the forevacuum side – at a sorption trap, for example – ensure that the components attached direct are not heated to more than 100 °C.

When baking out the pump, operate it with the water-cooling system on.

Following bakeout, retighten the clamp screws on the flange heater, if required.

Leave the flange heater on the TURBOVAC.

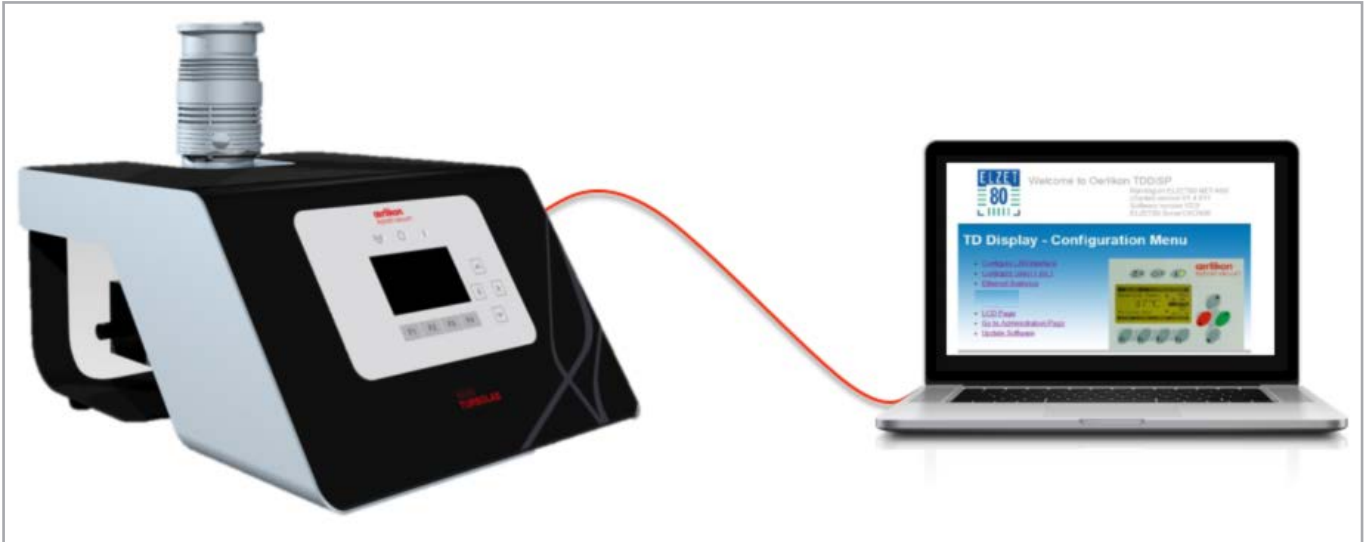

Fig. 4.4 Webservice connection

## 4.9 Webservice

Connect a computer to interface ETH (X150). Then use a browser to access the IP address of the TURBOLAB. You can find the IP address through Menü → System → Network Info or at Menü → System → QR Link.

In order to be able to operate the pump system through the Ethernet interface, the control hierarchy in the display must be changed to ETH Remote. Otherwise, it will only be possible to read parameters

### Logging in

Username: user

Password: user

Then press LOGIN.

# Operation

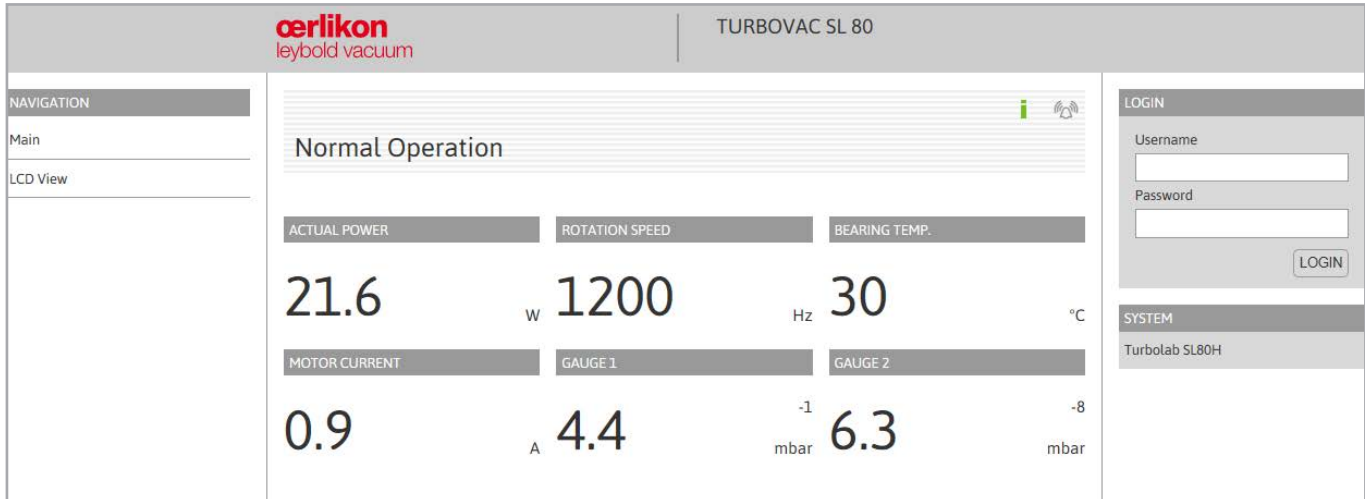

Fig. 4.5 Log in

## Start Screen

Through the start screen you may start your pump system, stop it and switch to standby operation. Moreover, the accessories can be controlled through the 4 function keys. Here also this status of the turbo pump is displayed in the upper status line.

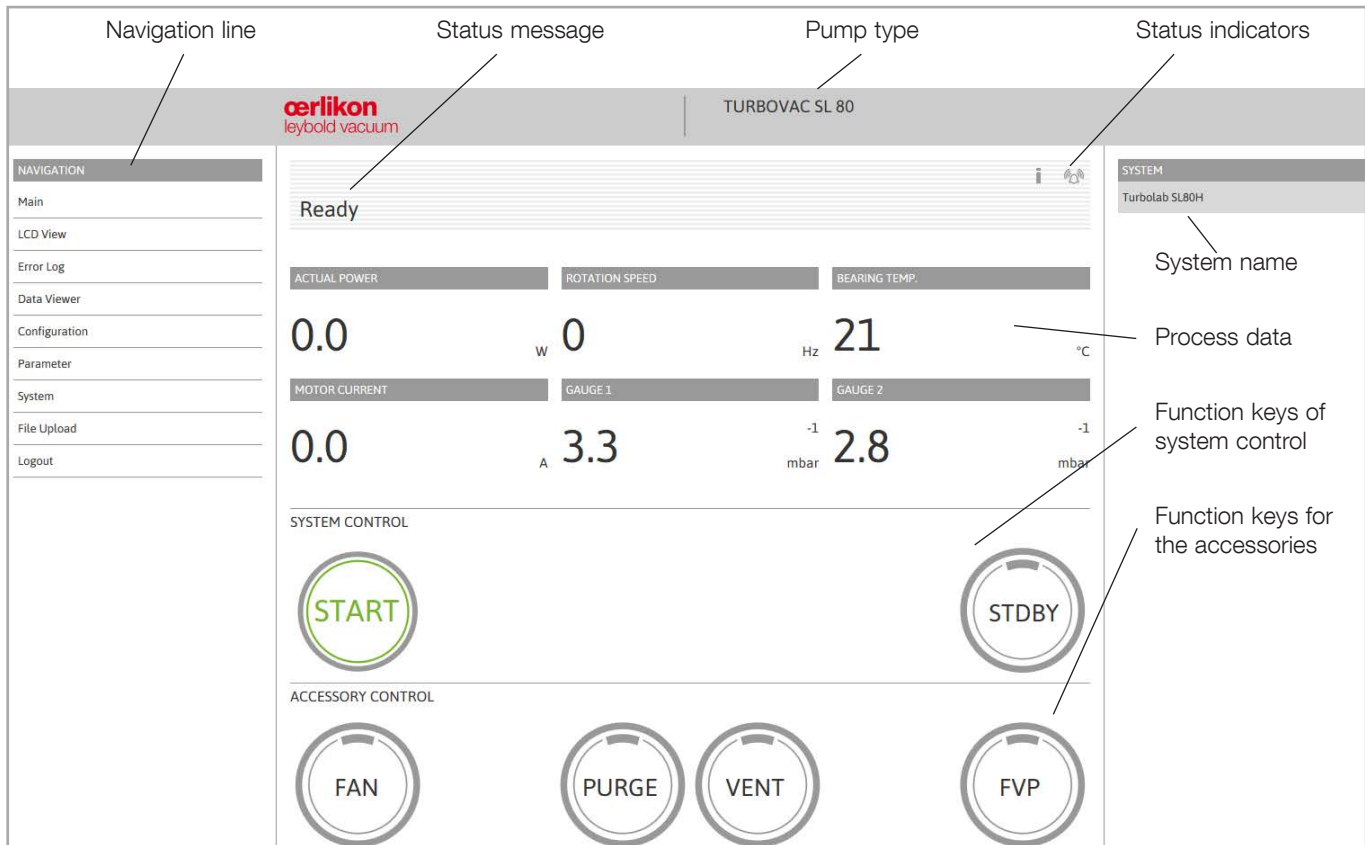

Fig. 4.6 Start screen

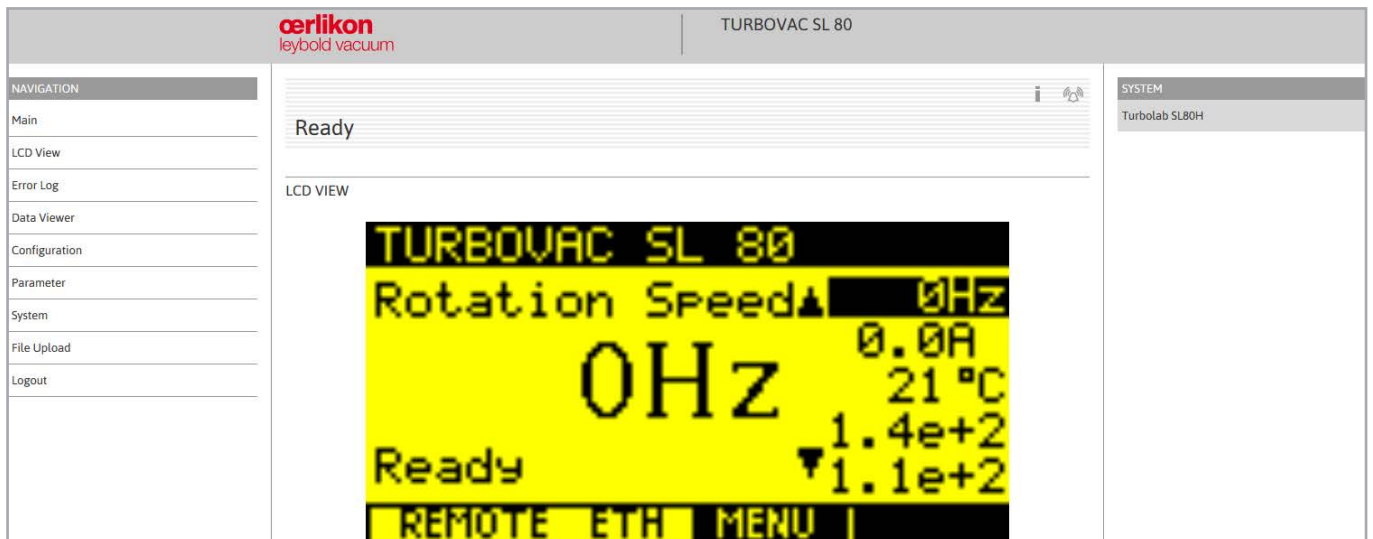

Fig. 4.7 LCD view

## LCD View

Through this function the display content of the pump system is shown through the web server.

## Error Memory

The error memory holds the errors of the turbo pump in chronological order. The operating time at the point of time the error has occurred is also indicated. By clicking on the corresponding line of the error, a detailed description will be displayed.

# Operation



Fig. 4.8 DataViewer

## DataViewer

To correctly display the trend of the data even after a longer downtime fully powered down it is necessary that the instrument has recorded 512 data records first. Depending on the setup LoggingCycle this can take more or less time. When initialising the LoggingCycle we recommend setting it to 1 second.

Through the corresponding checkmarks the measurement data can be selected. The queried data is updated constantly in a table placed under the graph.

Through parameter I900 you may modify the LoggingCycle. Through the LoggingCycle you may define the distance in time the individual data records are recorded.

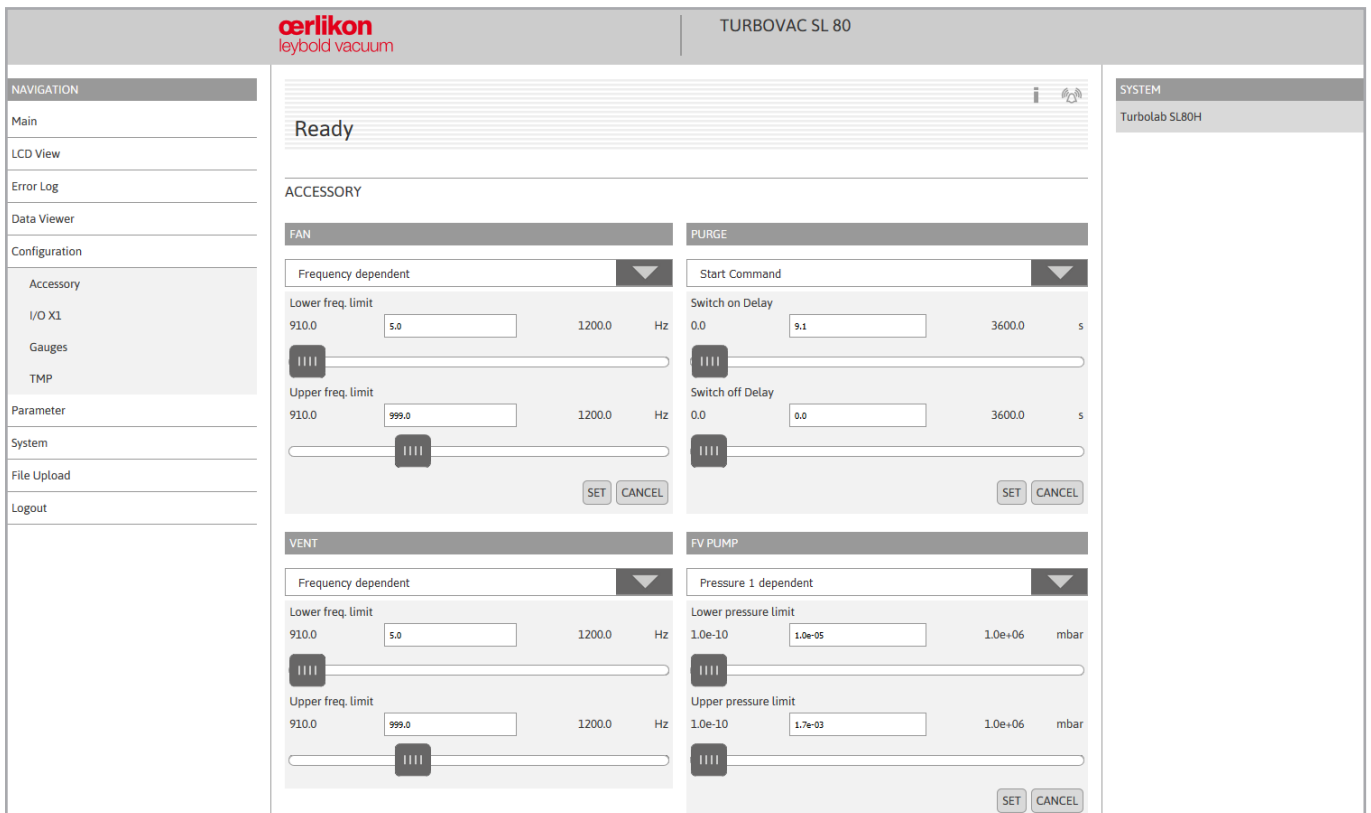

Fig. 4.9 Accessories configuration

## Configuration Menu

### Accessories

Through this submenu you may change the different accessory functions by selecting these from a drop-down list. These functions are explained in the Section “Function Codes of the Accessory Connections”. The values may either be entered directly or through sliders. Operating SET sets the value. The subsequent saving dialogue permanently saves, by operating SAVE, a value which has been set.



### X1 Interface (Menu I/O X1)

Here you may change the relay functions corresponding to the information given in the Section “Relay Functions”. For the analog output you may select between six different functions. Through SET and SAVE the values are saved.

# Operation

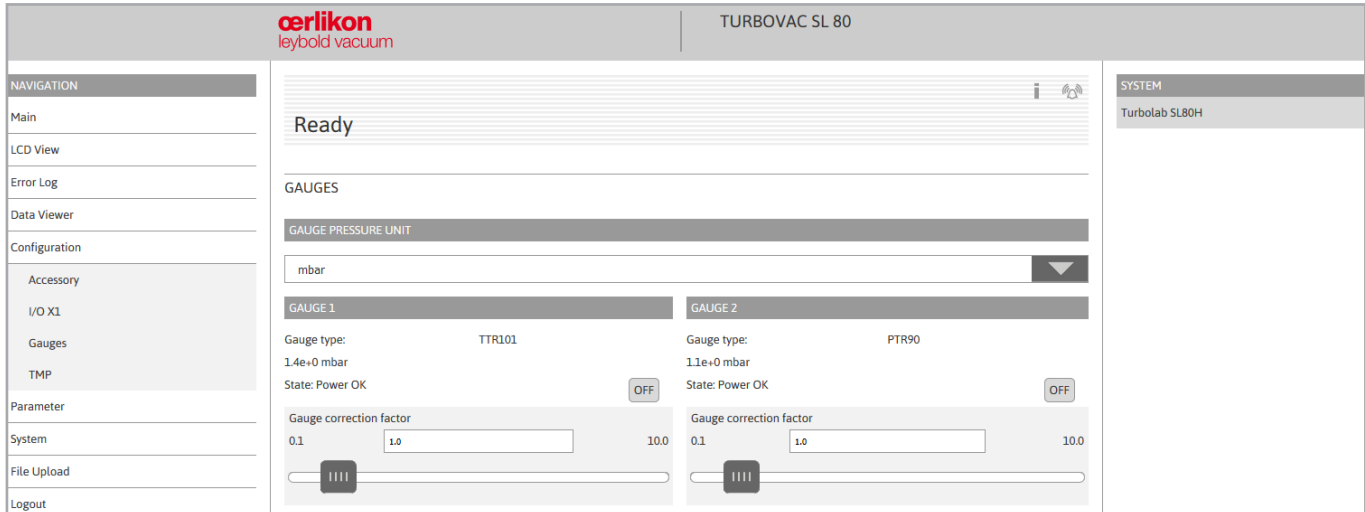

Fig. 4.10 Configuration menu for the gauges

## Gauges

Here you may select between the units of measurement millibar, Torr and Pascal via the drop-down list. These settings are carried over to the start screen. The types of vacuum gauge, the values currently measured and the vacuum gauge head status are displayed. Through OFF the vacuum gauge head may be switched off. The gas type correction factor needs to be set up according to the Operating Instructions for the respective vacuum gauge head. You may enter the value through the entry field or the slider.

## Turbomolecular pump (Menu TMP)

Here you may select between two options:

- The turbomolecular pump starts upon issuing the start command. Here the entered pressure values are disregarded.
- The turbomolecular pump starts depending on the pressure as soon as the pressure as measured by the selected vacuum gauge head has dropped below the preset threshold. The threshold may be entered directly or set up through a slider.

## Parameters

Through the parameter menu you may select via the drop-down list the respective parameters. When wanting to change a parameter you may do this through the entry field or through the slider. Through SET and SAVE, the values are saved.



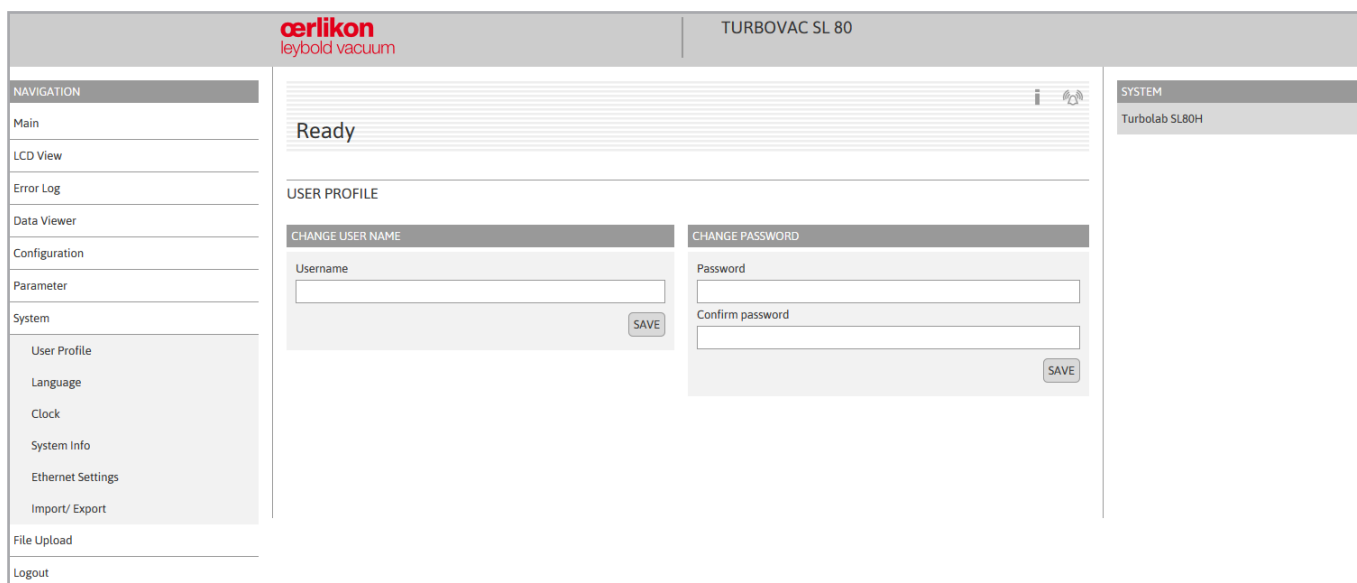

Fig. 4.11 System menu: user profile

## System Menu

### User Profile

Through the user profile you may change the log-in data for the web server.

### Language

Through the drop-down list you may change the language from German to English and vice versa.

### Clock

The clock menu can be used to change the time and date settings of the system. Here it is also possible to import the current time from the PC.

### Internet Settings

The menu Internet Settings displays the current IP address of the device, the subnet mask, the DNS server, the gateway address as well as the DHCP status. All these data can be changed through the entry field and the drop-down list.

### Import/Export

Through this submenu you may export the previously entered settings to a file. This file with the current settings may then be imported to a different device or used for backing up data.

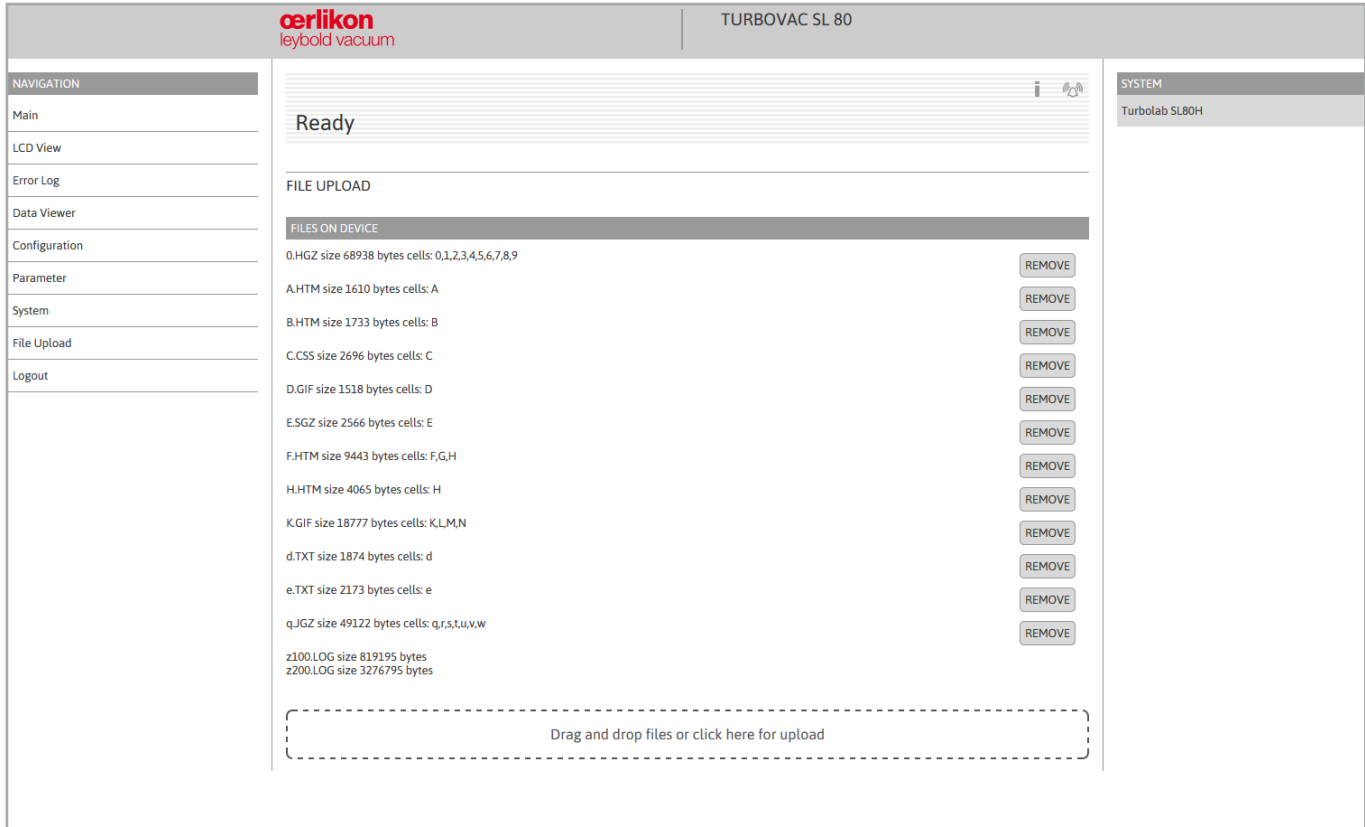

Fig. 4.12 File upload

## File Upload

Through the file upload menu you may load files into the device and also remove these. This includes, for example, files needed for a software update. These may be moved by drag-and-drop into the field with the dashed rectangle or you may select by clicking on this field. FILE UPLOAD loads the selected file into the device.

However, if this file is already present in the device, it needs to be removed first. A dialogue is displayed indicating the line which is to be overwritten and which needs to be deleted. Only after having through REMOVE deleted the line, will a transfer become possible.

A software update can be run on the same principle as described in the "File Upload".

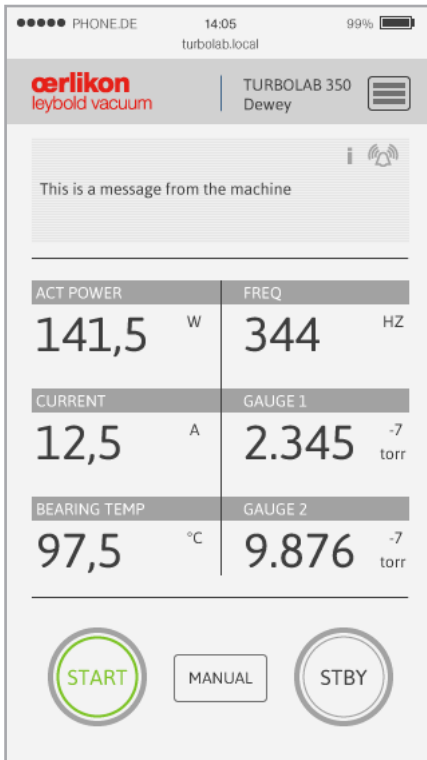

Fig. 4.13 Webserver views: Main

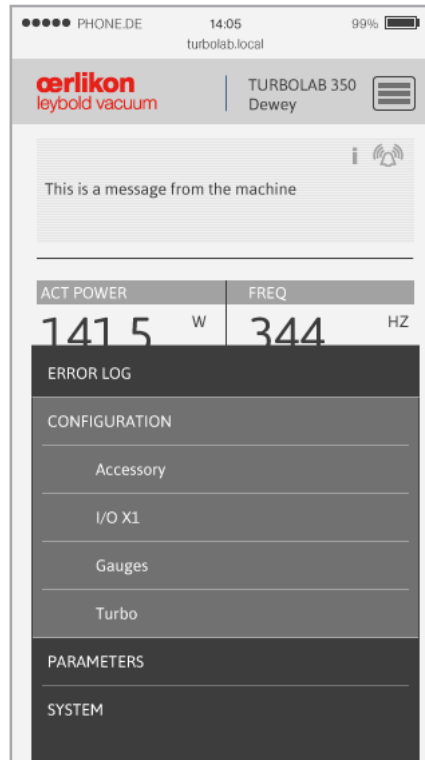

Fig. 4.14 Webserver views: Navigation

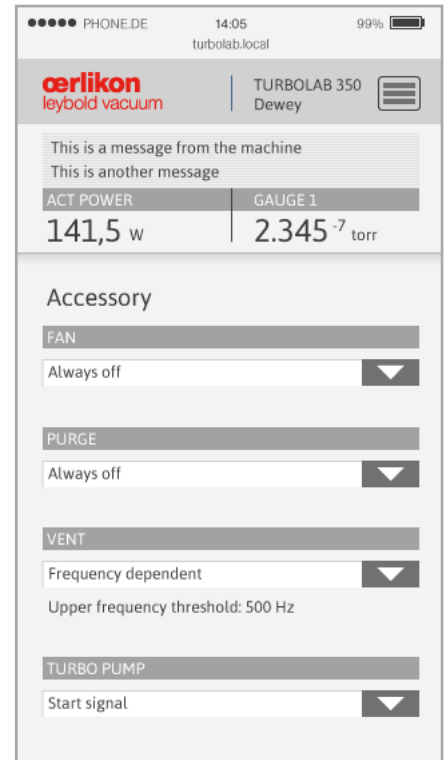

Fig. 4.15 Webserver views: Accessory setting

You may also operate the web server on a smart phone; then the menus will look slightly different, see above.

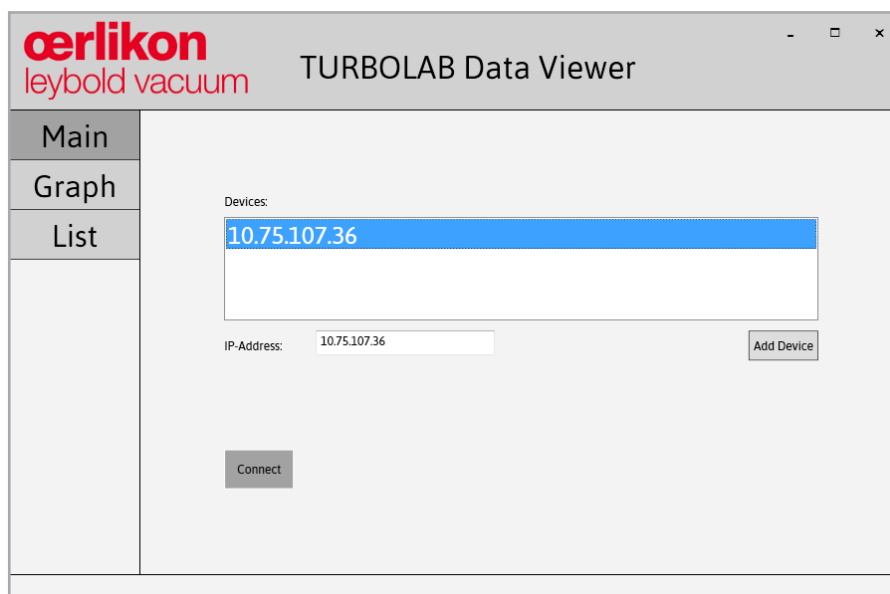

Fig. 4.16 Start screen of the DataViewer

## 4.10 Data Viewer

This tool serves the purpose of analysing and assessing the data recorded from the pump system. Here the process engineering measurement data is displayed by way of a graph as well as in a table.

### Establishing the Link

To establish a link with the device, enter the IP address of the device into the entry field "IP-Address". Then confirm the IP address through **Add Device**. If the IP address is correct then it will be displayed in the "Devices Window. To establish the link, click on the IP address and confirm through **Connect**.

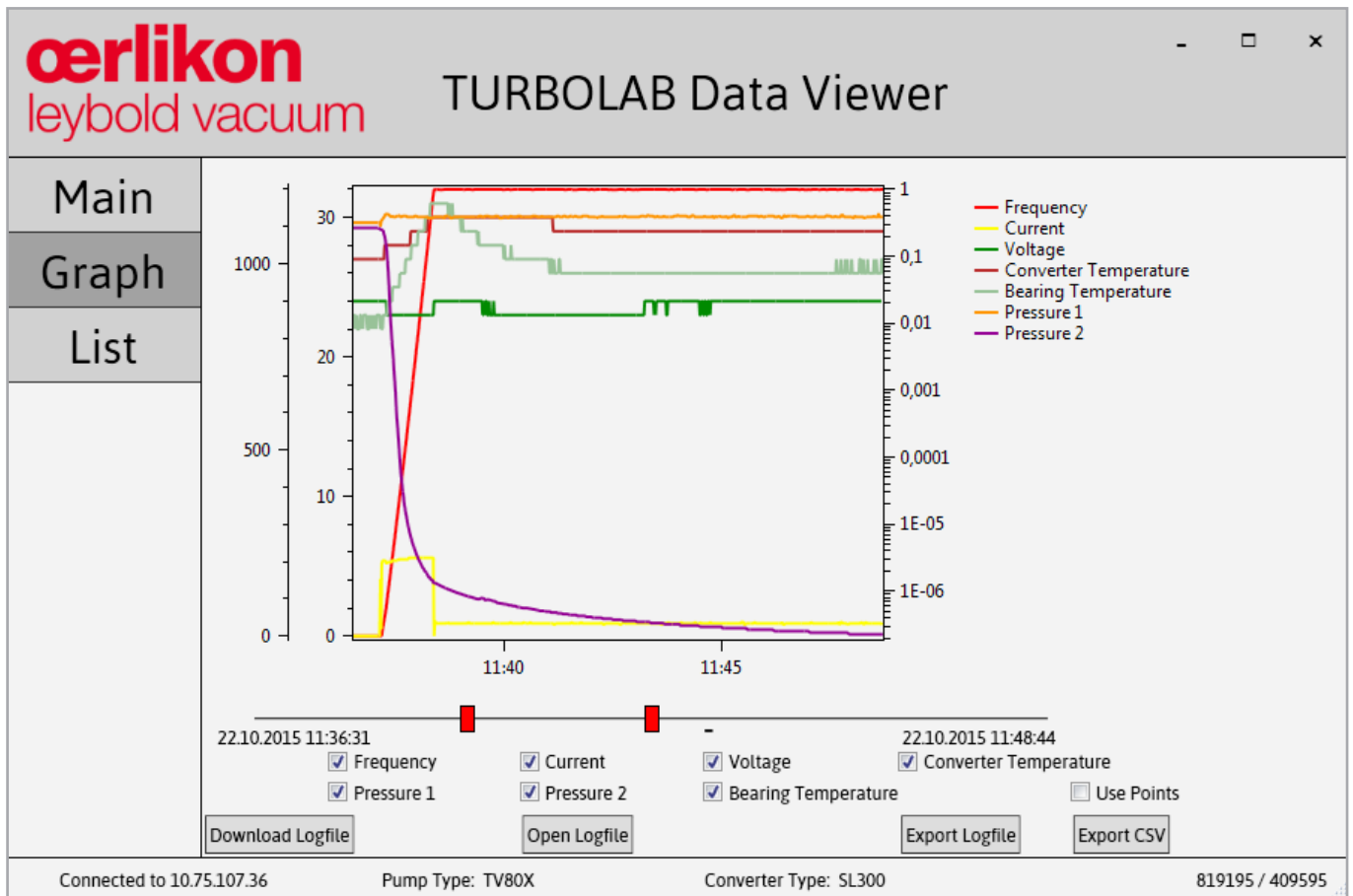

Fig. 4.17 Trend display

The buttons in the lower section of the display allow the following:

- Loading data from the device. Downloading is indicated through the counter incrementing at the bottom right-hand corner.
- Opening a previously exported log file
- Exporting a downloaded log file into a .log file
- Exporting a downloaded log file to the Excel CSV file format

### Trend Display

Here the measured trend data is displayed in a graph. Through the red sliders, the selection window may be moved to a certain point of time and you may zoom into the data. Zooming into the data is effected also through the third mouse key or the key combination ALT + left mouse button. To remove or show the data, switch the checkmark at the corresponding data off or on.

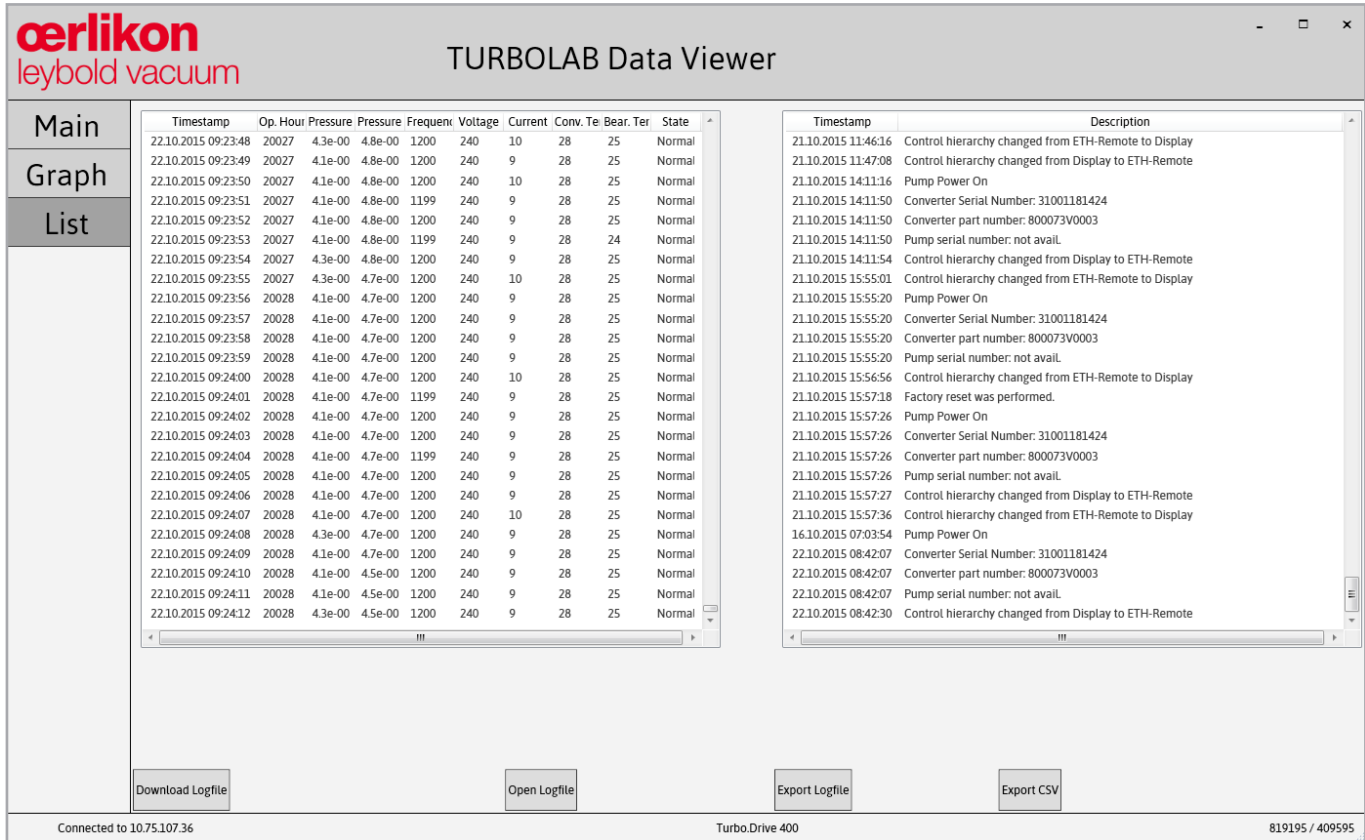

Fig. 4.18 Data list

## Data List

Through the data list, all recorded data points can be viewed. Double-clicking on a line with the data records then displays the corresponding point within the graph. Moreover, all occurred events are listed in the right-hand window.

## LoggingCycle

See Section Webservice → DataViewer → LoggingCycle

## Memory Capacity

For an estimate as to how long the device will be capable of recording data, refer to the following formula:

The log file has a size of 3264512 bytes →  $3264512/32 = 102016$  entries in the log file.

→  $102016 \text{ entries} \times 1 \text{ second (LoggingCycle)} = 102016 \text{ seconds}$ .

From this there results a recording duration of approximately 1700 minutes which is roughly equal to 28 hours.

The recording duration will vary depending on the selected LoggingCycle.

## **Device List**

When wanting to remove any added devices from the device list, remove these entries from the file "device.txt". This file can be found in the DataViewer Folder.

## 5 Maintenance

### Rotor exchange

We recommend an exchange of the rotor unit after 80,000 operating hours at the latest.

Such maintenance work can only be done by the Oerlikon Leybold Vacuum Service. If required contact the Oerlikon Leybold Vacuum service center nearest to your location. You can find the address on our internet page [www.oerlikon.com](http://www.oerlikon.com).

At high pump loads - for example during cyclic operation, at high gas throughputs or at high ambient temperatures - the aforementioned maintenance work should be carried forward. Please consult Oerlikon Leybold Vacuum for recommendations.

### Purge gas filter

Depending on the degree of contamination of the purge gas used the filter will clog and will have to be exchanged (our experience indicates that this will become necessary after 1 to 6 months).

### Adsorption trap

When an adsorption trap is used, regenerate or renew the adsorption agent regularly; refer to the operating instructions provided with the trap.

### Backing pump

As to maintenance work on the backing pump, please observe the information given in the corresponding Operating Instructions.

---

#### DANGER



Before beginning with any kind of maintenance work switch the pump system off and pull the mains plug.

### 5.1 Cleaning

Remove dust on the surfaces using a moist piece of cloth only to prevent the creation of any sparks.

#### Cleaning the frequency converter internally

The frequency converter is basically maintenance free, since it does not contain any adjustable components.

Depending on the installation and ambient conditions, the frequency converter can suffer from the internal contamination (dust, humidity). Such contamination can result in malfunctions, overheating or short circuits and therefore needs to be avoided as far as possible. The Oerlikon Leybold Vacuum Service can clean the frequency converter. Here we are recommending cleaning intervals of approximately 5 years.

#### Cleaning the TURBOVAC internally

Contamination inside the TURBOVAC is indicated by a deterioration in performance, i. e. an increasing decline in working pressure.

If there is only slight contamination, such as a coating on the TURBOVAC interior surfaces due to exposure to the atmosphere over an extended period of time, the flange heater can be used for cleaning.

The ultimate pressure must be monitored while baking out under vacuum.

When making the initial examination of the pump, mount blank flanges to eliminate any possibility of leaks and desorption in the vacuum chamber.



The pump will have to be disassembled if there is more extensive contamination. The Oerlikon Leybold Vacuum Customer Service Department will have to be consulted here in all cases.

## 5.2 Oil of the Rotary Vane Pump

The TRIVAC or SOGEVAC requires for proper operation sufficiently fresh and suitable oil.

The oil level of the forevacuum pump must be checked at least once a week.

The oil must be changed when appears contaminated, chemically changed or mechanically worn out. When the oil contaminates too rapidly, install a dust and/or an oil filter.

Precise information on this topic and on other maintenance works is provided in the Operating Instructions for the rotary vane pump.

With the gas ballast valve open, a larger quantity of oil escapes from the rotary vane pump so that the oil level will have to be checked more frequently under such operating conditions.

## 5.3 Removing the Forevacuum Pump

Each foot on the forevacuum pump is bolted to the base plate by a bolt and three nuts. The nut accessible from above is bonded to the bolt; the two nuts accessible from below are counter-tightened.

To remove the forevacuum pump, un-screw the counter-tightened nuts beneath the base plate, and lift off the pump.

After removing the forevacuum pump, seal both connecting flanges.

## 5.4 Oerlikon Leybold Vacuum Service

Whenever you send us in equipment, indicate whether the equipment is contaminated or is free of substances which could pose a health hazard. If it is contaminated, specify exactly which substances are involved. You must use the form we have prepared for this purpose.

A copy of the form has been reproduced at the end of these Operating Instructions: "Declaration of Contamination for Compressors, Vacuum Pumps and Components". Another suitable form is available from [www.oerlikon.com/leyboldvacuum](http://www.oerlikon.com/leyboldvacuum) → Documents → Download Documents.

Attach the form to each contaminated pump.

This statement detailing the type of contamination is required to satisfy legal requirements and for the protection of our employees.

We must return to the sender any equipment which is not accompanied by a contamination statement.

### Contamination

### Form

# Troubleshooting

## 6 Troubleshooting

Parameter 171 contains in the case of an error the corresponding error code. For the respective error, the corresponding rotor frequency and the corresponding number of operating hours at that point of time the error has occurred is saved under the parameters 174 and 176 at the same index number.

Listed in the following are the possible error codes and their causes.

Error code	Designation	Possible cause	Remedy
1	Overspeed warning. The actual frequency exceeds the setpoint by over 10 Hz.	Frequency converter defective	Contact Oerlikon Leybold Vacuum Service.
2	Pass through time error The pump has not reached the minimum speed after the maximum run-up time has elapsed.	Forevacuum pressure too high. Gas flow too high Rotor blocked	Check the ultimate pressure of the backing pump and install a bigger backing pump if req. Seal leak, check process Check if the rotor turns freely. Contact Oerlikon Leybold Vacuum Service if the rotor is damaged or blocked.
3	Bearing temperature error. The maximum permissible bearing temperature was exceeded.	Forevacuum pressure too high. Gas flow too high Fan defective Water cooling switched off	Check the ultimate pressure of the backing pump and install a bigger backing pump if req. Seal leak, check process Replace fan Switch on water cooling
4	Short circuit error		
5	Converter temperature error Overtemperature at the power output stage or within the frequency converter	Ambient temperature too high Poor cooling	Ensure max. ambient temperature of 35°C Improve cooling
6	Run-up time error The pump has not reached the normal operating frequency after the maximum run-up time.	Forevacuum pressure too high. Gas flow too high	Check the ultimate pressure of the backing pump and install a bigger backing pump if req. Seal leak, check process
7	Motor temperature error The motor temperature has exceeded the shutdown threshold.	Forevacuum pressure too high. Gas flow too high Fan defective Water cooling switched off	Check the ultimate pressure of the backing pump and install a bigger backing pump if req. Seal leak, check process Replace fan Switch on water cooling
8	Pump error: The pump could not be identified or no pump has been connected.	Pump not correctly connected to the frequency converter. Defective hardware	Check the connection between pump and frequency converter. Contact Oerlikon Leybold Vacuum Service.
61	Bearing temperature warning, top		
82	Fan voltage has failed		
83	Motor temperature low warning		
84	Motor overtemperature warning		

# Troubleshooting

Error code	Designation	Possible cause	Remedy
85 to 96	Frequency converter collective error		
97	Internal volume temperature error		
101	Overload warning The pump speed has dropped under the normal operation threshold	Forevacuum pressure too high. Gas flow too high	Check the ultimate pressure of the backing pump and install a bigger backing pump if req. Seal leak, check process
103	Supply voltage warning Intermediate circuit voltage too low or maximum time for generator operation was exceeded.	DC supply voltage below 24V or 48 V Mains voltage has failed	Check the voltage at the power supply and if required set up correctly Remedy the cause for the mains power failure
106	Overload error The pump speed has dropped under the minimum speed	Forevacuum pressure too high. Gas flow too high	Check the ultimate pressure of the backing pump and install a bigger backing pump if req. Seal leak, check process
111	The minimum permissible motor temperature is not attained.	Ambient temperature too low Pump cooling too high	Ensure min. ambient temperature of 5 °C Reduce water cooling
116	The speed of the pump has dropped below the normal operation threshold and has stayed there for a longer period of time.	Forevacuum pressure too high. Gas flow too high	Check the ultimate pressure of the backing pump and install a bigger backing pump if req. Seal leak, check process
117	Motor current error (start-up error), Motor current below nominal current, switchover from open loop controlled to closed loop controlled operation was not successful	Cable fault Faulty connector	Contact Oerlikon Leybold Vacuum Service
126	Bearing temperature sensor error, top	Defective component, short-circuit or broken cable	Contact Oerlikon Leybold Vacuum Service
128	Motor temperature sensor error	Defective component, short-circuit or broken cable	Contact Oerlikon Leybold Vacuum Service
143	Overspeed error		
225	Bearing break-in function active		Disable bearing break-in function and restart the pump
226	Temperature derating active. One of the temperature warning values was exceeded and the maximum permissible motor current was reduced		
227 to 238	Frequency converter collective error	DIVAC 0.8 / 3.0 (24 V DC) is not turning although the function code was set up correctly, fuse F4 has blown.	Check fuse F4 (8A slow-blow) and replace as required. The location of the fuses is indicated in fig. 3.7 and 3.8. Reset error, try to restart. If this is not possible inform Oerlikon Leybold Vacuum Service or send in the pump.

# Troubleshooting

<b>Error code</b>	<b>Designation</b>	<b>Possible cause</b>	<b>Remedy</b>
240	EEPROM error (CRC) inconsistent data in the EEPROM		Reset error, try to restart. If this is not possible inform Oerlikon Leybold Vacuum Service or send in the pump.
252	Hardware plausibility error. Frequency converter and communication electronics are not from the same pump	Front end and frequency converter were interchanged.  The LEDs of the turbomolecular pump do not indicate a status although communication and power supply have been plugged in correctly, fuse F3 has blown.	Establish the correct hardware configuration or run a software update  Check fuse F3 (10 A slow-blow) and replace as required.  The location of the fuses is indicated in fig. 3.7 and 3.8.
	Display remains dark.	Fuse F5 has blown.	Check fuse F5 (2 A slow-blow) and replace as required.  The location of the fuses is indicated in fig. 3.7 and 3.8.

## 7 Waste Disposal

The equipment may have been contaminated by the process or by environmental influences. In this case the equipment must be decontaminated in accordance with the relevant regulations. We offer this service at fixed prices. Further details are available on request.

Contaminated parts can be detrimental to health and environment. Before beginning with any work, first find out whether any parts are contaminated. Adhere to the relevant regulations and take the necessary precautions when handling contaminated parts.

Separate clean components according to their materials, and dispose of these accordingly. We offer this service. Further details are available on request.

When sending us any equipment, observe the regulations given in Section "5.4 Oerlikon Leybold Vacuum Service".

### Disposal of Waste Oil

Owners of waste oil are entirely self-responsible for proper disposal of this waste.

Waste oil from vacuum pumps must not be mixed with other substances or materials.

Waste oil from vacuum pumps (Oerlikon Leybold Vacuum oils which are based on mineral oils) which are subject to normal wear and which are contaminated due to the influence of oxygen in the air, high temperatures or mechanical wear must be disposed of through the locally available waste oil disposal system.

Waste oil from vacuum pumps which is contaminated with other substances must be marked and stored in such a way that the type of contamination is apparent. This waste must be disposed of as special waste.

European, national and regional regulations concerning waste disposal need to be observed. Waste must only be transported and disposed of by an approved waste disposal vendor.

### Contamination

---

#### WARNING



## EC- Declaration of Conformity

**The manufacturer:** Oerlikon Leybold Vacuum GmbH  
Bonner Straße 498  
D-50968 Köln  
Germany

herewith declares that the products specified and listed below which we have placed on the market, comply with the applicable EC Council Directives. This declaration becomes invalid if modifications are made to the product without agreement of Oerlikon Leybold Vacuum GmbH.

**Product designation:** Vacuum pump system  
**Type designation:** 1. Turbolab xxx  
2. Turbolab xxx Cart  
(xxx can be 80, 350 or 450)  
**Part numbers:** 501592Vxxxxxxxx (x=0-9)

**The products complies to the following European Council Directives:**

Machinery Directive (2006/42/EC)

The safety objectives of the Low Voltage Directive 2006/95/EC were complied with in accordance with Appendix 1 No. 1.5.1 of Machinery Directive 2006/42/EC.

Electromagnetic Compatibility (2004/108/EC)

**The following harmonized standards have been applied:**

EN 1012-2:1996+A1:2009	Compressors and vacuum pumps - Safety requirements Part 2: Vacuum pumps
EN 61010-1:2010	Safety requirements for electrical equipment for measurement, control and laboratory use - Part 1: General requirements
EN 61326-1:2013	Electrical equipment for measurement, control and laboratory use - EMC requirements - Part 1: General requirements Emission: Group 1 Class B Immunity: Industrial electromagnetic environment

**Documentation officer:** Herbert Etges  
Tel.: +49(0)221 347-0  
Fax: + 49(0)221 347 1250  
E-Mail: [documentation.vacuum@oerlikon.com](mailto:documentation.vacuum@oerlikon.com)

Cologne, November 12<sup>th</sup>, 2015

Cologne, November 12<sup>th</sup>, 2015

  
ppa. Harald Udelhoven  
Head of Product Line High Vacuum

  
ppa. Dr. Monika Mattern-Klosson  
Head of Quality & Business Process Management

## Declaration of Contamination of Compressors, Vacuum Pumps and Components

The repair and / or servicing of compressors, vacuum pumps and components will be carried out only if a correctly completed declaration has been submitted. Non-completion will result in delay. The manufacturer can refuse to accept any equipment without a declaration.

**A separate declaration has to be completed for each single component.**

This declaration may be completed and signed only by authorized and qualified staff.

Customer/Dep./Institute : _____ Address : _____ _____ Person to contact: _____ Phone : _____ Fax: _____ End user : _____	Reason for return: <input checked="" type="checkbox"/> applicable please mark <b>Repair:</b> <input type="checkbox"/> chargeable <input type="checkbox"/> warranty <b>Exchange:</b> <input type="checkbox"/> chargeable <input type="checkbox"/> warranty <input type="checkbox"/> Exchange already arranged / received <b>Return only:</b> <input type="checkbox"/> rent <input type="checkbox"/> loan <input type="checkbox"/> for credit <b>Calibration:</b> <input type="checkbox"/> DKD <input type="checkbox"/> Factory-calibr. <input type="checkbox"/> Quality test certificate DIN 55350-18-4.2.1
---	--

<b>A. Description of the product:</b> Material description : _____ Catalog number: _____ Serial number: _____ Type of oil (ForeVacuum-Pumps) : _____	<b>Failure description:</b> _____ <b>Additional parts:</b> _____ <b>Application-Tool:</b> _____ <b>Application- Process:</b> _____
--	---

<b>B. Condition of the equipment</b>	<b>No<sup>1)</sup></b>	<b>Yes</b>	<b>No</b>		<b>Contamination :</b>	<b>No<sup>1)</sup></b>	<b>Yes</b>
1. Has the equipment been used	<input type="checkbox"/>	<input type="checkbox"/>	<input type="checkbox"/>	→	toxic	<input type="checkbox"/>	<input type="checkbox"/>
2. Drained (Product/service fluid)	↓	<input type="checkbox"/>	<input type="checkbox"/>		corrosive	<input type="checkbox"/>	<input type="checkbox"/>
3. All openings sealed airtight	<input type="checkbox"/>	<input type="checkbox"/>	<input type="checkbox"/>		flammable	<input type="checkbox"/>	<input type="checkbox"/>
4. Purged	<input type="checkbox"/>	<input type="checkbox"/>	<input type="checkbox"/>		explosive <sup>2)</sup>	<input type="checkbox"/>	<input type="checkbox"/>
If yes, which cleaning agent					radioactive <sup>2)</sup>	<input type="checkbox"/>	<input type="checkbox"/>
and which method of cleaning					microbiological <sup>2)</sup>	<input type="checkbox"/>	<input type="checkbox"/>
<sup>1)</sup> If answered with "No", go to D. ←					other harmful substances	<input type="checkbox"/>	<input type="checkbox"/>

**C. Description of processed substances (Please fill in absolutely)**

1. **What substances have come into contact with the equipment ?**  
 Trade name and / or chemical term of service fluids and substances processed, properties of the substances  
 According to safety data sheet (e.g. toxic, inflammable, corrosive, radioactive)

X	Tradename:	Chemical name:
a)		
b)		
c)		
d)		

2. Are these substances harmful ?  No  Yes ←

3. Dangerous decomposition products when heated ?  No  Yes ←

If yes, which ? \_\_\_\_\_

<sup>2)</sup> Components contaminated by microbiological, explosive or radioactive products/substances will not be accepted without written evidence of decontamination.

### D. Legally binding declaration

I / we hereby declare that the information supplied on this form is accurate and sufficient to judge any contamination level.

Name of authorized person (block letters) : \_\_\_\_\_

\_\_\_\_\_

Date signature of authorized person

\_\_\_\_\_  
 firm stamp



# Sales and Service

## Germany

**Oerlikon Leybold Vacuum GmbH**  
Sales, Service, Support Center (3SC)  
Bonner Strasse 498  
D-50968 Cologne  
Phone: +49-(0)221-347 1234  
Fax: +49-(0)221-347 31234  
sales.vacuum@oerlikon.com  
www.oerlikon.com/leyboldvacuum

**Oerlikon Leybold Vacuum GmbH**  
**Sales Area North**  
Branch Office Berlin  
Industriestrasse 10b  
D-12099 Berlin  
Phone: +49-(0)30-435 609 0  
Fax: +49-(0)30-435 609 10  
sales.vacuum.bn@oerlikon.com

**Oerlikon Leybold Vacuum GmbH**  
**Sales Office South**  
Branch Office Munich  
Karl-Hammerschmidt-Strasse 34  
D-85609 Aschheim-Dornach  
Phone: +49-(0)89-357 33 9-10  
Fax: +49-(0)89-357 33 9-33  
sales.vacuum.mn@oerlikon.com  
service.vacuum.mn@oerlikon.com

**Oerlikon Leybold Vacuum**  
**Dresden GmbH**  
**Service Competence Center**  
Zur Wetterwarte 50, Haus 304  
D-01109 Dresden  
Service:  
Phone: +49-(0)351-88 55 00  
Fax: +49-(0)351-88 55 041  
info.vacuum.dr@oerlikon.com

## Europe

### Belgium

**Oerlikon Leybold Vacuum**  
**Nederland B.V.**  
**Belgisch bijkantoor**  
Leuvensesteenweg 542-9A  
B-1930 Zaventem  
Sales:  
Phone: +32-2-711 00 83  
Fax: +32-2-720 83 38  
sales.vacuum.zv@oerlikon.com  
Service:  
Phone: +32-2-711 00 82  
Fax: +32-2-720 83 38  
service.vacuum.zv@oerlikon.com

### France

**Oerlikon Leybold Vacuum**  
**France S.A.S.**  
Parc du Technopolis, Bâtiment Beta  
3, Avenue du Canada  
F-91940 Les Ulis cedex  
Sales and Service:  
Phone: +33-1-69 82 48 00  
Fax: +33-1-69 07 57 38  
info.vacuum.ctb@oerlikon.com  
sales.vacuum.ctb@oerlikon.com

**Oerlikon Leybold Vacuum**  
**France S.A.S.**  
Valence Factory  
640, Rue A. Bergès  
B.P. 107  
F-26501 Bourg-lès-Valence Cedex  
Phone: +33-4-75 82 33 00  
Fax: +33-4-75 82 92 69  
marketing.vacuum.vc@oerlikon.com

## Great Britain

**Oerlikon Leybold Vacuum**  
**UK LTD.**  
Unit 9  
Silverglade Business Park  
Leatherhead Road  
Chessington  
Surrey (London)  
KT9 2QL  
Sales:  
Phone: +44-13-7273 7300  
Fax: +44-13-7273 7301  
sales.vacuum.ln@oerlikon.com  
Service:  
Phone: +44-13-7273 7320  
Fax: +44-13-7273 7303  
service.vacuum.ln@oerlikon.com

## Italy

**Oerlikon Leybold Vacuum**  
**Italia S.r.l.**  
Via Trasimeno 8  
I-20128 Mailand  
Sales:  
Phone: +39-02-27 22 31  
Fax: +39-02-27 20 96 41  
sales.vacuum.mi@oerlikon.com  
Service:  
Phone: +39-02-27 22 31  
Fax: +39-02-27 22 32 17  
service.vacuum.mi@oerlikon.com

## Netherlands

**Oerlikon Leybold Vacuum**  
**Nederland B.V.**  
Floridadreef 102  
NL-3565 AM Utrecht  
Sales and Service:  
Phone: +31-(30) 242 63 30  
Fax: +31-(30) 242 63 31  
sales.vacuum.ut@oerlikon.com  
service.vacuum.ut@oerlikon.com

## Switzerland

**Oerlikon Leybold Vacuum**  
**Schweiz AG, Pfäffikon**  
Churerstrasse 120  
CH-8808 Pfäffikon  
Warehouse and shipping address:  
Riedthofstrasse 214  
CH-8105 Regensdorf  
Sales:  
Phone: +41-44-308 40 50  
Fax: +41-44-302 43 73  
sales.vacuum.zh@oerlikon.com  
Service:  
Phone: +41-44-308 40 62  
Fax: +41-44-308 40 60  
service.vacuum.zh@oerlikon.com

## Spain

**Oerlikon Leybold Vacuum**  
**Spain, S.A.**  
C/. Huelva, 7  
E-08940 Cornellà de Llobregat  
(Barcelona)  
Sales:  
Phone: +34-93-666 43 11  
Fax: +34-93-666 43 70  
sales.vacuum.ba@oerlikon.com  
Service:  
Phone: +34-93-666 46 11  
Fax: +34-93-685 43 70  
service.vacuum.ba@oerlikon.com

## America

### USA

**Oerlikon Leybold Vacuum**  
**USA Inc.**  
5700 Mellon Road  
USA-Export, PA 15632  
Phone: +1-724-327-5700  
Fax: +1-724-325-3577  
info.vacuum.ex@oerlikon.com  
Sales:  
Phone: +1-724-327-5700  
Fax: +1-724-333-1217  
Service:  
Phone: +1-724-327-5700  
Fax: +1-724-325-3577

### Brazil

**Oerlikon Leybold Vacuum**  
**Brasil**  
Rod. Vice-Prefeito Hermenegildo Tonolli,  
nº. 4413 - 6B  
Distrito Industrial  
Jundiá - SP  
CEP 13.212-315  
Sales and Service:  
Phone: +55 11 2152 0499  
Fax: +55 11 99467 5934  
sales.vacuum.ju@oerlikon.com  
service.vacuum.ju@oerlikon.com

## Asia

### P. R. China

**Oerlikon Leybold Vacuum (Tianjin)**  
**International Trade Co. Ltd.**  
Beichen Economic  
Development Area (BEDA),  
No. 8 Western Shuangchen Road  
Tianjin 300400  
China  
Sales and Service:  
Phone: +86-22-2697 0808  
Fax: +86-22-2697 4061  
Fax: +86-22-2697 2017  
sales.vacuum.tj@oerlikon.com  
service.vacuum.tj@oerlikon.com

### India

**Oerlikon Leybold Vacuum**  
**India Pvt Ltd.**  
No. 82(P), 4th Phase  
K.I.A.D.B. Plot  
Bommasandra Industrial Area  
Bangalore - 560 099  
Indien  
Sales and Service:  
Phone: +91-80-2783 9925  
Fax: +91-80-2783 9926  
sales.vacuum.bgl@oerlikon.com  
service.vacuum.bgl@oerlikon.com

### Japan

**Oerlikon Leybold Vacuum**  
**Japan Co., Ltd.**  
Headquarters  
Shin-Yokohama A.K.Bldg., 4th floor  
3-23-3, Shin-Yokohama  
Kohoku-ku, Yokohama-shi  
Kanawaga 222-0033  
Japan  
Sales:  
Phone: +81-45-471-3330  
Fax: +81-45-471-3323  
info.vacuum.yh@oerlikon.com  
sales.vacuum.yh@oerlikon.com

## Oerlikon Leybold Vacuum

**Japan Co., Ltd.**  
Tsukuba Technical Service Center  
1959, Kami-yokoba  
Tsukuba-shi, Ibaraki-shi 305-0854  
Japan  
Service:  
Phone: +81-29 839 5480  
Fax: +81-29 839 5485  
service.vacuum.iik@oerlikon.com

## Malaysia

**Oerlikon Leybold Malaysia**  
**Oerlikon Leybold Vacuum**  
**Singapore Pte Ltd.**  
No. 1 Jalan Hi-Tech 2/6  
Kulim Hi-Tech Park  
Kulim, Kedah Darul  
Aman 09000  
Malaysia  
Sales and Service:  
Phone: +604 4020 222  
Fax: +604 4020 221  
sales.vacuum.ku@oerlikon.com  
service.vacuum.ku@oerlikon.com

## South Korea

**Oerlikon Leybold Vacuum**  
**Korea Ltd.**  
3F. Jellzone 2 Tower  
Jeongja-dong 159-4  
Bundang-gu Sungnam-si  
Gyeonggi-do  
Bundang 463-384, Korea  
Sales:  
Phone: +82-31 785 1367  
Fax: +82-31 785 1359  
sales.vacuum.bd@oerlikon.com  
Service:  
623-7, Ulsung-Dong  
Cheonan-Si  
Chungcheongnam-Do  
Korea 330-290  
Phone: +82-41 589 3035  
Fax: +82-41 588 0166  
service.vacuum.cn@oerlikon.com

## Singapore

**Oerlikon Leybold Vacuum**  
**Singapore Pte Ltd.**  
8 Commonwealth Lane #01-01  
Singapore 149555  
Singapore  
Sales and Service:  
Phone: +65-6303 7030  
Fax: +65-6773 0039  
sales.vacuum.sg@oerlikon.com  
service.vacuum.sg@oerlikon.com

## Taiwan

**Oerlikon Leybold Vacuum**  
**Taiwan Ltd.**  
No 416-1, Sec. 3  
Chunghsin Rd., Chutung  
Hsinchu County 310  
Taiwan, R.O.C.  
Sales and Service:  
Phone: +886-3-500 1688  
Fax: +886-3-583 3999  
sales.vacuum.hc@oerlikon.com  
service.vacuum.hc@oerlikon.com

**Oerlikon**  
**Leybold Vacuum GmbH**  
Bonner Strasse 498  
D-50968 Cologne  
Phone: +49-(0)221-347 0  
Fax: +49-(0)221-347 1250  
info.vacuum@oerlikon.com

**oerlikon**  
leybold vacuum

www.oerlikon.com/  
leyboldvacuum