

PENNINGVAC Transmitter

PTR 90 N

Operating Manual 300544657_002_A1

Part Numbers:

- 230070V02
- 230085V02
- 230071V02
- 230072V02
- 230088V02
- 230089V02

Contents

0	Safety Information	3
0.1	Symbols used	3
0.2	Personnel Qualifications	3
0.3	General safety information	3
0.4	Liability and Warranty	5
1	Unpacking	6
2	Description	7
2.1	Technical Data	8
2.2	Dimensions	9
2.3	Accessories and replacement part numbers	11
3	Transmitter Installation (Mechanical)	12
3.1	Conforming utilization	12
3.2	Non-conforming utilization	12
3.3	Process compatibility	12
3.4	Vacuum connections	13
4	Transmitter Installation (Electrical)	14
4.1	Input/Output Wiring	15
4.2	Setpoint relays	17
5	Operations	18
5.1	Pressure output	18
5.2	Cold Cathode Ignition	19
5.3	Analog output	20
5.4	Sensor gas dependence	22
6	Functions	23
6.1	LED-ring/LED status indicator	23
6.2	Vacuum-zero/full-scale adjustment and setpoint adjustments	24
6.3	User switch adjustments	26
6.4	Integrated touch display	28
7	FAQ (Frequently Asked Questions)	30
8	Troubleshooting	32
9	Maintenance	33
9.1	Cold cathode maintenance	33
10	Declaration of Contamination	34
11	Declaration of Conformity	36
12	Notes	37
13	Sales and Service	38

0 Safety Information

0.1 Symbols used

The first two symbols identify other information in this manual that is essential or useful in achieving optimal performance from the transmitter. The last symbol below is used throughout this manual to further define the safety concerns associated with the product.

 **Critical**
Failure to read message could result in damage to the equipment.

 **Attention**
Calls attention to important procedures, practices or conditions.

 **Caution**
Refer to manual. Failure to read message could result in personal injury or serious damage to the equipment or both.

0.2 Personnel Qualifications



 **Skilled personnel**
All work described in this document may only be carried out by persons who have suitable technical training and the necessary experience or who have been instructed by the end-user of the product.



0.3 General safety information

The safety instructions should always be followed during installation and operation of the transmitter.
Pass safety information to all users.

- Adhere to the applicable regulations and take the necessary precautions for the process media used. Consider possible reactions between the materials and the process media. Consider possible reactions (e.g. explosion) of the process media due to the heat generated by the product.
- Adhere to the applicable regulations and take the necessary precautions for all work you are going to do and consider the safety instructions in this document.
- Before beginning to work, find out whether any vacuum components are contaminated. Adhere to the relevant regulations and take the necessary precautions when handling contaminated parts.

Safety Precautions:

 **Critical**
 **Service and Repair.** Do not substitute parts or modify instrument other than described in chapter 9. Do not install substituted parts or perform any unauthorized modification to the instrument. Return the instrument to an Oerlikon Leybold Vacuum Calibration and Service Center for service and repair to ensure all of the safety features are maintained.

 **Critical**
 **Explosive Environments.** Do not use the transmitter in presence of flammable gases or other explosive environments.
Corrosive Environments. The transmitter is not intended for use in corrosive environments. Refer to Transmitter installation chapter 3 of this manual. If you need further support please contact OLV.



STOP Critical

Danger: Magnetic fields

Strong magnetic fields can disturb electronic devices like heart pacemakers or impair their function.



Maintain a safety distance of ≥ 10 cm between the magnet and the heart pacemaker or prevent the influence of strong magnetic fields by antimagnetic shielding.

STOP Critical



DANGER: Overpressure in the vacuum system 2.5 bar < p < 5 bar

KF flange connections with elastomer seals (e.g. O-rings) cannot withstand such pressures.

Process media can thus leak and possibly damage your health. Use O-ring with an outer centering ring + 3-part clamping ring (clamping collar).

STOP Critical



DANGER: contaminated parts

Contaminated parts can be detrimental to health and environment. Before beginning to work, find out whether any parts are contaminated. Adhere to the relevant regulations and take the necessary precautions when handling contaminated parts.

Attention



Caution: vacuum component

Dirt and damages impair the function of the vacuum component. When handling vacuum components, take appropriate measures to ensure cleanliness and prevent damages.

Attention



CE marking The transmitter complies with European standards for CE marking. Refer to Declaration of Conformity chapter 11 of this manual.

Caution



Fuse. The transmitter power supply input has an internal thermal fuse. The fuse is self-recoverable and should not be changed.

Caution



Electrical connections. The transmitter must be properly electrically connected in order to perform according to the specifications.

Output pins are not protected against wrong electrical connections. Wrong electrical connections can cause permanent damage to the transmitter or interference to measuring performance. Refer to electrical connections description in chapter 4 of this manual.



Caution

Caution: dirt sensitive area

Touching the product or parts thereof with one's bare hands increases the desorption rate. Always wear clean, lint-free gloves and use clean tools when working in this area.

0.4 Liability and Warranty

Oerlikon Leybold Vacuum assumes no liability and the warranty becomes null and void if the end-user or third parties

- disregard the information in this document
- use the product in a non-conforming manner
- make any kind of interventions (modifications, alterations etc.) on the product
- use the product with accessories not listed in the product documentation

The end-user assumes the responsibility in conjunction with the process media used. Transmitter failures due to contamination are not covered by the warranty.

1 Unpacking

Before unpacking your transmitter, check all surfaces of the packing material for shipping damage. Inspect for visible damage. If found, notify the carrier immediately.

Please be sure that your transmitter package contains these items:

- 1 pcs. PTR 90 N PENNINGVAC Transmitter
- 1 pcs. English short form manual (P/N: 300544671_002_A0)
- 1 pcs. German short form manual (P/N: 300544671_001_A0)
- 1 pcs. Product Inspection and Test Report
- 1 pcs. Pin for adjusting settings via button (only for P/N: 230085V02, 230071V02, 230072V02, 230088V02).

If any items are missing, please contact Oerlikon Leybold Vacuum.

2 Description

The PTR 90 N PENNINGVAC series vacuum transmitters offer a wide measuring range from 1×10^{-8} mbar to 1000 mbar and are based on measurement of thermal conductivity in a small cavity on a MEMS Pirani silicon chip sensor and cold cathode (CC) ionization current.

Transmitter versions with RS232 digital communication interface (P/N: 230088V02) or EtherCAT digital communication interface (P/N: 230089V02) can set up transmitter parameters and provide real time pressure measurement. Please see the Communication Protocol 300544663 (RS232) and 300544664 (EtherCAT) for further details. Transmitter versions with an Integrated touchscreen display (P/N: 2300085V02) have the possibility to monitor essential transmitter parameters. Please see chapter 6.4 for further details.

Each transmitter is individually tested throughout the measuring range before leaving the factory. A test report is included in the package. In addition, each transmitter pressure reading is individually temperature-compensated within the specified operating temperature range.

The transmitters can be used in a variety of applications as standalone unit or with Graphix controllers (P/N: 230680V01, 230681V01, 230682V01) and the Display controllers (P/N: 230001, 230024, 230025). All PENNINGVAC transmitters are backward compatible with Graphix, Display and Center controllers.

The transmitters have up to three mechanical relays which can be used for process control, for example interlocking valves or pumps. The analog voltage output can be interfaced to external analog equipment for pressure readout or control.

Sensor technology

The transmitters contain two separate sensor elements. The MEMS Pirani (MEMS = Micro-Electro-Mechanical-System) sensor element is based on measurement of thermal conductivity. The MEMS Pirani sensor consists of a silicon chip with a heated resistive element forming one surface of a cavity. A cover on top of the chip forms the other surface of the cavity. Due to the geometry of the sensor, convection cannot take place within the cavity and consequently the sensor is insensitive to mounting position. Gas molecules are passed by diffusion only to the heated element where the heat loss of the gas is measured.

The cold cathode inverted magnetron utilizes a high voltage anode, cathode and a permanent magnet. Electrons are accelerated towards the anode and will ionize molecules by collision. The magnetic field deflects the electrons, causing them to spiral as they move across the magnetic field to the anode. This spiraling movement increases the opportunity for them to encounter and ionize the molecules.

The ionization of the molecules creates an electric current as a function of the pressure. Both sensor elements are very robust and can withstand high G-forces and fast inrushes of air.

Applications

The transmitters can be used in many different vacuum applications within the industrial application, research and development, semiconductor, analytical and coating industries:

- General vacuum pressure measurement
- Gas backfilling measurement and controlling
- Coating
- Mass spectrometer control
- System process control
- Sense abnormal pressure and take appropriate security measures using setpoint relays
- Control system pressure

Disposal

The PTR 90 N PENNINGVAC transmitter is manufactured according to the RoHS directive.



Attention

For the benefit of the environment, at the end of life of the transmitter, it should not be disposed in the normal unsorted waste stream. It should be deposited at an appropriate collection point or facility to enable recovery or recycling.

2.1 Technical Data

Measurement principle:	Thermal conductivity according to a MEMS Pirani sensor Cold cathode ionization current	
Display range (N ₂ and Air):	1×10 ⁻⁸ to 1000 mbar	
Accuracy ⁽¹⁾ (N ₂):	1×10 ⁻⁸ to 1×10 ⁻³ mbar (CC):	±30% of reading
	1×10 ⁻⁴ to 1×10 ⁻³ mbar (MP):	±10% of reading
	1×10 ⁻³ to 100 mbar (MP):	± 5% of reading
	100 to 1000 mbar (MP):	± 25% of reading
Repeatability ⁽¹⁾ (N ₂):	1×10 ⁻³ to 100 mbar:	± 2% of reading
Supply Voltage:	9 – 30 VDC	
Power consumption:	< 2 Watt	
Fuse (thermal recoverable):	200 mA	
Analog output (100 Ω impedance):	2-8.6 VDC, Log. 0.6 VDC/decade	
Analog output resolution:	16 bit	
Analog output update rate:	16 Hz	
Sensor fail analog output (Pirani):	10 VDC	
Materials exposed to vacuum ⁽²⁾ :	304 stainless steel, sealing material FPM	
Mechanical Setpoint relay(s):		
P/N: 230070V02, 230071V02, 230072V02, 230085V02:	0	
P/N: 230088V02:	3	
Setpoint relay range:	1×10 ⁻⁸ to 1000 mbar	
Setpoint relay contact rating:	1 A / 30 VDC/AC (resistive load)	
Setpoint relay contact resistance:	100 mΩ (max)	
Setpoint relay response time:	<100 ms	
Setpoint relay contact endurance:	100,000 cycles (min) (30 VDC/1 A load)	
Setpoint relay contact endurance:	2,000,000 cycles (min) (30 VDC/0.2 A load)	
Software setpoint relays:		
P/N: 230089V02:	2	
Setpoint relay response time:	< 20 ms	
Internal volume:	KF25	28.6 cm ³
	KF40	21.7 cm ³
	CF46	32.7 cm ³
Housing material:	Stainless steel 304	
Weight:		
P/N: 230070V02, 230088V02:	321 g	
P/N: 230089V02:	600 g	
P/N: 230085V02:	550 g	
P/N: 230071V02:	358 g	
P/N: 230072V02:	576 g	
Maximum allowed pressure:	6 bar	
Operating temperature:	0 to 40 °C (32 to 104 °F)	
Bake out temperature (Power off):	85 °C (185 °F)	
Filament temperature:	35 °C above ambient temperature	
Ingress Protection Rating:	IP40	
Leak rate	< 5.10 ⁻⁹ mbar·l/s	

(1) Accuracy and repeatability are typical values measured in Nitrogen atmosphere after zero adjustment at ambient temperature.

(2) For the full list of all materials exposed to process gases please contact OLV.

2.2 Dimensions

[mm]

P/N: 230070V02, 230071V02, 230072V02

P/N: 230088V02

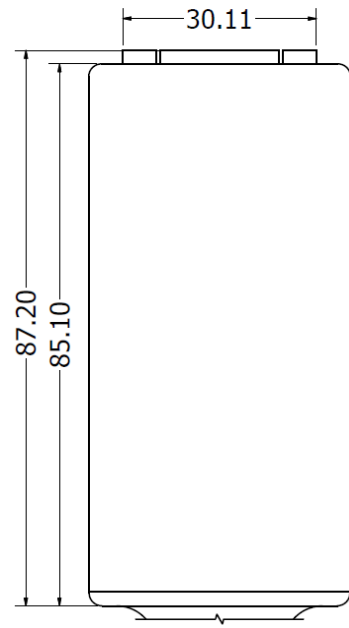
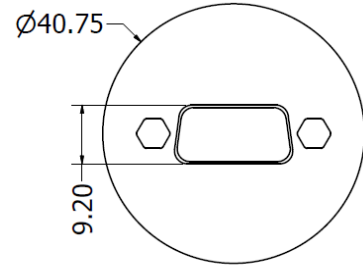
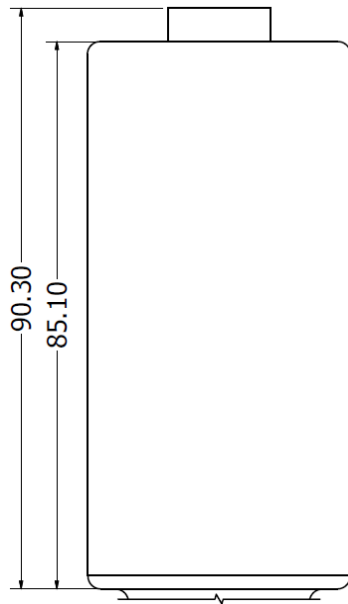
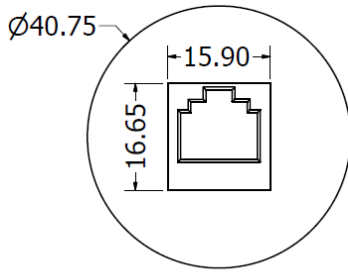

P/N: 230085V02

P/N: 230089V02

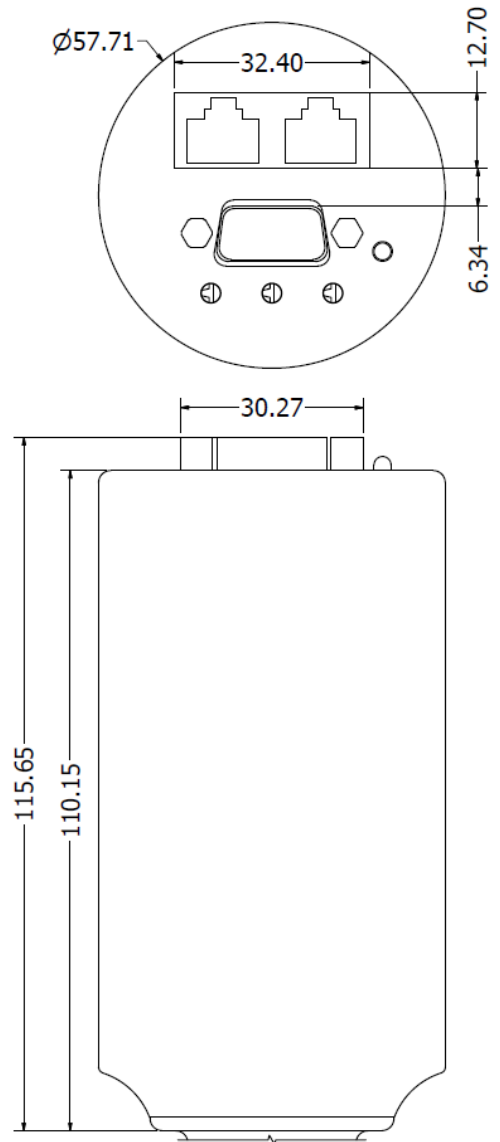
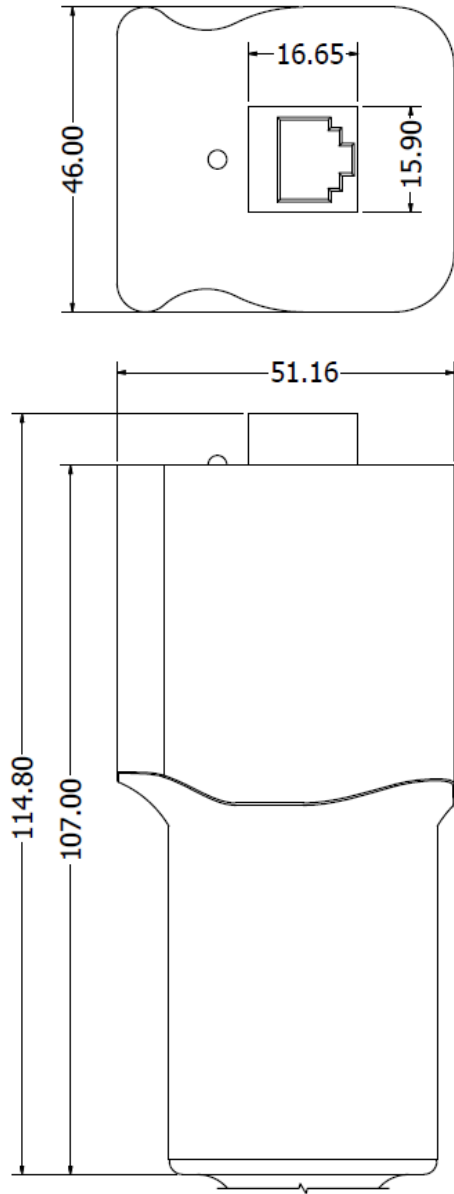

Flanges

KF 25

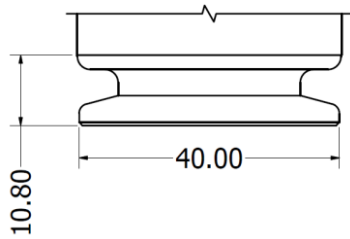

KF 40

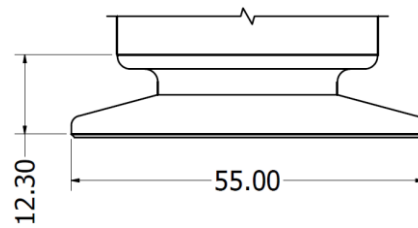

CF 40

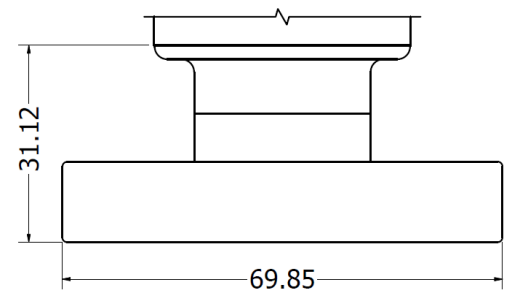

2.3 Accessories and replacement part numbers

Part	Part no.
PTR 90 N, DN25 KF	230070V02
PTR 90 N, DN25 KF; Display	230085V02
PTR 90 N, DN40 KF	230071V02
PTR 90 N, DN40 CF	230072V02
PTR 90 N, DN25 KF, RS232, 3SP	230088V02
PTR 90 N, DN25 KF, EtherCAT	230089V02
Replacement cathode plates PTR 90 N / PTR 225 N	EK16291V02
Replacement anode ring PTR 90 N / PTR 225 N	20028711V02
Display One	230001
Display Two	230024
Display Three	230025
Graphix One	230680V01
Graphix Two	230681V01
Graphix Three	230682V01
Cables Type A 5 Meter	12426
Cables Type A 10 Meter	230012
Cables Type A 15 Meter	12427
Cables Type A 20 Meter	12428
Cables Type A 30 Meter	12429
Cables Type A 50 Meter	12431
Cables Type A 75 Meter	12432
Cables Type A 100 Meter	12433
Spiral tube DN 25 ISO-KF	230083
Spiral tube DN 40 ISO-KF	230084
Centering Rings (Stainless Steel 1.4305) with O-Ring	88374
Centering Rings (Stainless Steel) with Sintered Metal Filter	88352
Clamping Rings (Aluminum)	210043
Baffle, with centering ring (FPM)	230078

3 Transmitter Installation (Mechanical)

3.1 Conforming utilization

- The transmitter is intended for measuring pressure.
- The transmitters are intended for use in relatively clean environments.
- The transmitter can only be used by persons who have suitable technical training and the necessary experience or who have been instructed by the end-user of the product.
- Always ensure that all vacuum sealing items and surfaces are clean, without damage and free of particles.
- Use a cable with strain relief to ensure proper electrical connection and to reduce stress on the connectors.
- To comply with EN61326-1 immunity requirements, use a braided, shielded cable.

3.2 Non-conforming utilization

- The transmitter cannot be used for measurements other than described in this manual.
- The transmitters are not intended for use in dirty and corrosive environments
- Do not use the transmitter in presence of flammable gases or other explosive environments.
- Do not install substituted parts or perform any unauthorized modification to the instrument.
- The transmitter is not intended for use above maximum allowed pressure.



3.3 Process compatibility

The PTR 90 N PENNINGVAC transmitters are intended for use in relatively clean environments. The transmitter cannot be used in corrosive environments like a semiconductor etch process chamber where aggressive gases such as fluorine are used.

If the transmitters are located close to a gas source connection like a flow controller or leak valve the transmitter pressure measurement can be higher than the actual chamber pressure. Location close to a pumping system connection can cause a lower pressure measurement than actual chamber pressure.

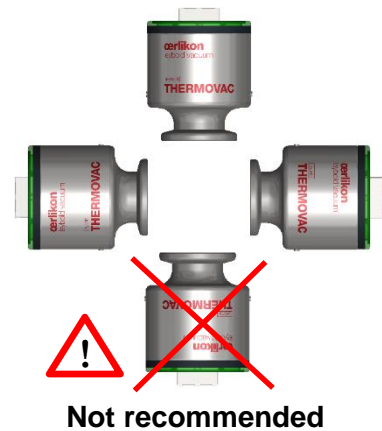
The transmitters and their sensor design can be mounted in any orientation without compromising accuracy. However it is not recommended to mount the transmitters upside down, as dust and dirt might fall into the sensor.



	 Caution
	Do not use or install the transmitter where the following conditions occur: <ul style="list-style-type: none">- Temperatures lower than 0 °C or higher than 40 °C- Corrosive or explosive gases- Direct sunlight or other heat sources

Explosive Environments

The transmitters should not be used in explosive environments, due to their high voltage potential that can cause ignition.

Temperature

The transmitters have an active and individual sensor temperature compensation circuit that ensures accurate measurement in a wide temperature range. For best measuring performance avoid large temperature gradients and direct cooling like air-condition air stream or direct heating like a pump exhaust stream.

Bake out

The transmitter electronics can withstand maximum 85 °C (185 °F) when the power is turned off.

Contamination

Locate and orient the transmitter where contamination is least likely. The MEMS Pirani sensor has a low filament temperature of only 35°C above ambient temperature; therefore, the MEMS Pirani is less prone to contamination by cracking products from fore vacuum pump oil.



Attention

If the transmitter is backfilled with a liquid like pump oil the sensor element is likely permanently damaged. The transmitter cannot be cleaned using solvents.

Vibrations and instant air inrush

The sensor elements are extremely robust to mechanical forces like vibration and G-forces.

The sensor element cannot be damaged by fast and repeated pressure cycles or instant inrush of air.

3.4 Vacuum connections

The transmitters are available with different types of vacuum fittings. When mounting the transmitter, always ensure that all vacuum sealing items and surfaces are clean, without damage and free of particles. Do not touch the vacuum flange sealing surface.



Caution

If the transmitter will be exposed to pressures above atmospheric pressure make sure that proper vacuum fittings are used. Ensure that the internal system pressure is at ambient pressure conditions before opening the vacuum system and removing any connections.

Pressure range

The standard PTR 90 N PENNINGVAC transmitters are internally sealed with elastomer FPM sealing for use down to 1×10^{-8} mbar. If used in UHV applications the out gassing rate of FPM can be too high.

4 Transmitter Installation (Electrical)

The PTR 90 N PENNINGVAC transmitters are available with different input/output connectors. Use a cable with strain relief to ensure proper electrical connection and to reduce stress on the connectors.



Attention



Ensure a low impedance electrical connection between the transmitter body and the grounded vacuum system to shield the sensor from external electromagnetic sources.
Ensure that the analog output is connected to floating input.

To comply with EN61326-1 immunity requirements, use a braided shielded cable. Connect the braid to the metal hoods at both ends of the cable with the end for power supply connected to earth ground.

Ground loops, differences of potential, or EMC problems may affect the measurement signal. For optimum signal quality, please do observe the following notes:

- Use an overall metal braided shielded cable. The connector must have a metal case.
- Connect the cable shield to ground at one side via the connector case. Make sure the connector case has direct contact to the cable's shield on its whole circumference. Do not connect the other side of the shield.
- Connect the supply common with protective ground directly at the power.
- Use differential measurement input (signal common and supply common conducted separately).
- Potential difference between supply common and housing ≤ 18 V (overvoltage protection).

The power supply input is 9 to 30 VDC. The power supply input is protected by an internal thermal fuse. The fuse is self-recoverable; do not replace it. Damage may occur to the circuitry if excessive voltage is applied, polarity reversed or if a wrong connection is made.

If using the analog voltage output, connect the positive analog out and negative analog out pins to a differential input voltmeter or an analog-to-digital (A/D) converter. Do not connect the negative side of the analog output to the negative side of the power supply input or to any other ground. Doing so will cause half of the power current to flow through this wire. Measurement errors in the output voltage may be seen due to the voltage drop from this current. The longer the cable, the worse the error will be. Do not connect the setpoint relay terminals to the analog output.

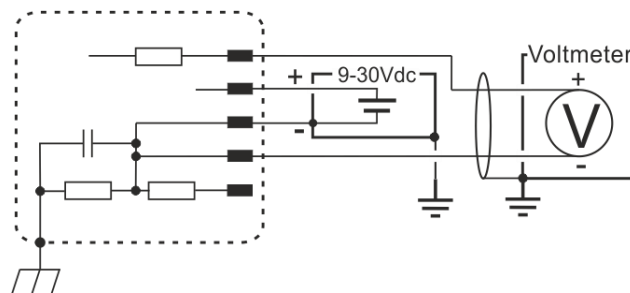

Correct connection of analog output to floating input

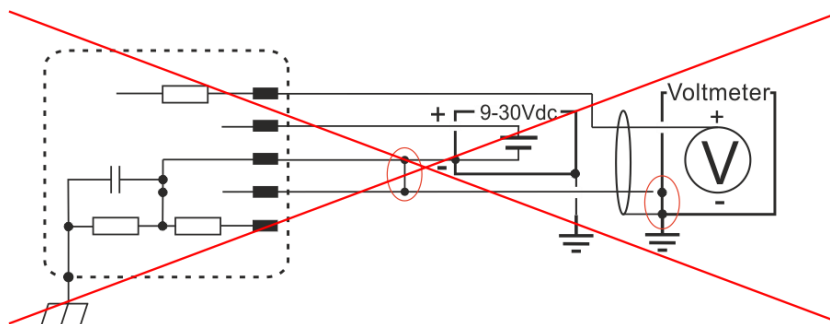

Incorrect connection of analog output to non-floating input

4.1 Input/Output Wiring

To comply with EN61326-1 immunity requirements, use a braided, shielded cable. Connect the braid to the metal hoods at both ends of the cable with the end for power supply connected to earth ground.

Part Numbers: 230070V02, 230071V02, 230072V02, 230085V02:

I/O Connector (8 pin RJ45/FCC68)

PIN Description

1	Power + (9-30 VDC)	5	Analog Output -
2	Power return - (GND)	6	Status
3	Analog Output +	7	Not Connected
4	ID-Resistor, 85 k Ω (\pm 1%)	8	Not Connected

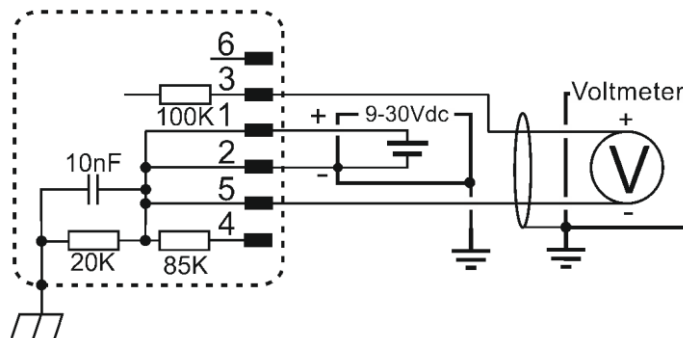
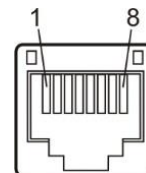

Part Numbers: 23088V02:

I/O Connector (15 pin HD Sub D male)

PIN Description

1	RS232 Transmit	9	Relay 1, Normally Closed
2	RS232 Receive	10	Relay 2, Normally Closed
3	Power + (9-30VDC)	11	Relay 2, Common
4	Power return - (GND)	12	Relay 2, Normally Open
5	Analog Output +	13	Relay 3, Normally Closed
6	Analog Output -	14	Relay 3, Common
7	Relay 1, Normally Open	15	Relay 3, Normally Open
8	Relay 1, Common		

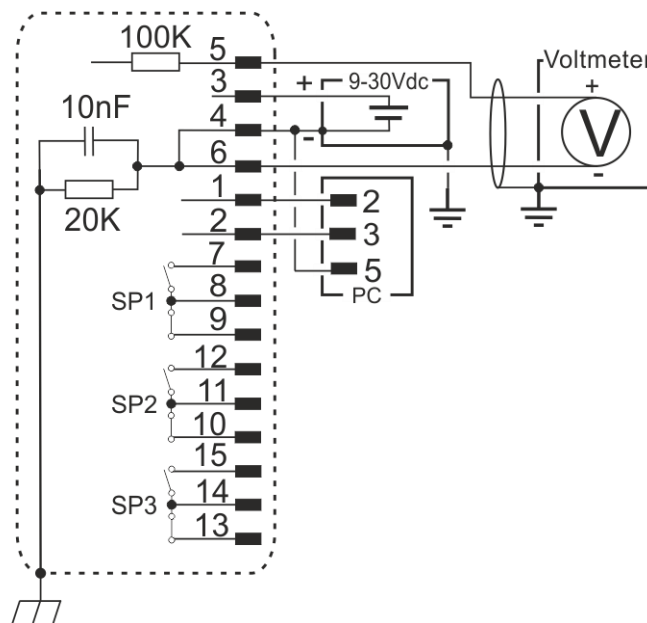
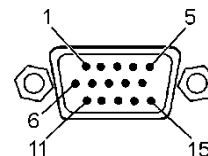

Part Numbers: 230089V02:

2 x I/O Connector (8 pin RJ45/FCC68): <IN> and <OUT>

PIN Description

1	TD+	5	Not Connected
2	TD-	6	RD-
3	RD+	7	Not Connected
4	Not Connected	8	Not Connected

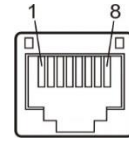

Part Numbers: 230089V02:

I/O Connector (15 pin HD Sub D male)

PIN Description

1	Not Connected	9	Not Connected
2	Not Connected	10	Not Connected
3	Power + (9-30 VDC)	11	Not Connected
4	Power return - (GND)	12	Not Connected
5	Analog Output +	13	Not Connected
6	Analog Output -	14	Not Connected
7	Not Connected	15	Chassis GND
8	Not Connected		

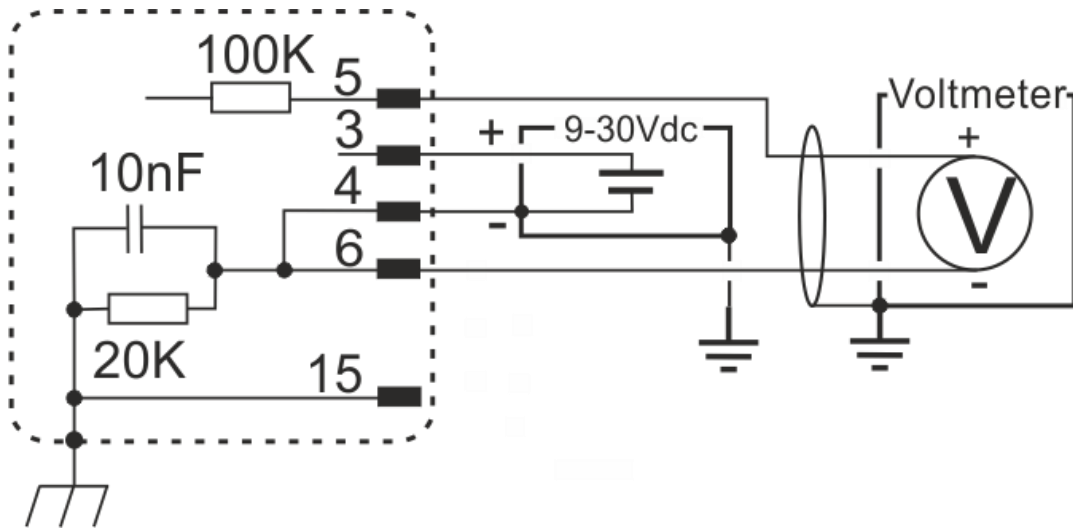
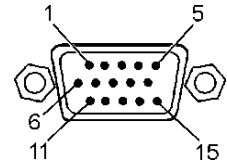

4.2 Setpoint relays

The PTR 90 N PENNINGVAC transmitters have up to 3 mechanical relays that can be used for controlling external process equipment. The relay has closing and breaking contacts and the contacts are rated 30 VDC, 1A resistive load. For the setup of the setpoints, refer to chapter 6.

Inductive relay load

Special precautions should be taken when driving inductive loads with the relay contact. When an inductive load like a solenoid is energized, the in-rush current is significant higher than the regular load current. In-rush currents exceeding the relay contact rating can cause reduction of relay contact life time or contact reliability. When a solenoid is de-energized, the collapsing magnetic field can cause significant voltage spikes. These spikes can couple capacitively from cable to cable and interfere with measuring electronics or transmitter signal.

STOP
Critical



Driving inductive loads via the setpoint relay contacts requires de-energizing spike protection. Inadequate protection can cause permanent damage to the transmitter or interfere with the analog output signal.

Always ensure that inductive in-rush currents do not exceed relay contact rating.

An arc suppression network, as shown schematically to the right, is recommended. The values of the capacitance C and the resistance R can be calculated by the following equations:

$$C = I^2 / (1 \times 10^7) \quad R = E / I^a$$

where:

C is in Farads. R is in ohms

I is DC or AC_{peak} load current in amperes. E is DC or AC_{peak} source voltage in volts

$$a = 1 + (50 / E)$$

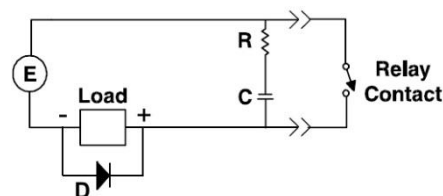

Note that $R_{min} = 0.5 \Omega$ and $C_{min} = 1 \times 10^{-9} F$, D is a fast transient suppression diode.

Setpoint functionality

The set point relays can be activated either above or below the set point values. The graphs below show the different relays stages in either below or above configuration. The NC contact will always be closed in case of power failure.

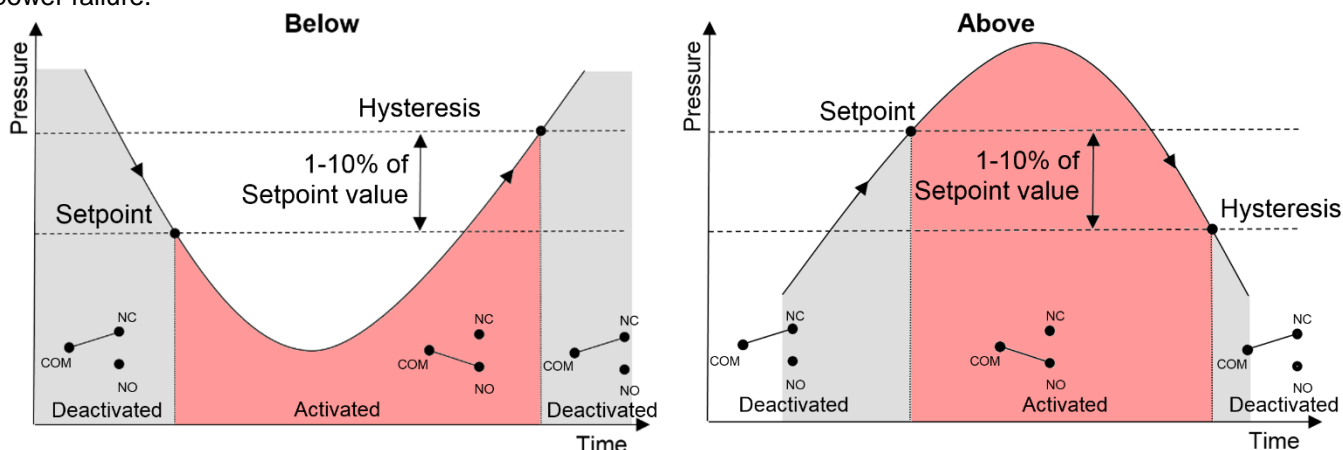

Please see the Oerlikon vacuum transmitter Communication Protocol 300544663 (RS232).

STOP
Critical



When using the setpoint relay to control process equipment always take appropriate precautions to prevent system damage in case of transmitter power failure. The NC contact will be closed in case of transmitter power failure.

5 Operations

5.1 Pressure output

The PTR 90 N PENNINGVAC transmitter can provide pressure measurement output as an analog voltage or RS232 digital value (P/N: 230088V02) or EtherCAT digital value (P/N: 230089V02). For details about the digital interface, please refer to the Communication Protocol 300544663 (RS232) and 300544664 (EtherCAT).

The default analog output is based on the MEMS Pirani and cold cathode combined reading and provides a 16 bit voltage output of 0.6 VDC/decade standard configurations. Refer to chapter 5.3 for details.

The MEMS Pirani automatically turns on the cold cathode at $6.7E-4$ mbar (SLC) and turns it off at $1.1E-3$ mbar (SHC). Above $5.3E-4$ mbar, the combined reading is the MEMS Pirani pressure measurement and below $1.3E-4$ mbar it is the cold cathode pressure measurement. Between $1.3E-4$ and $5.3E-4$ mbar, the two measurements are smoothly integrated.

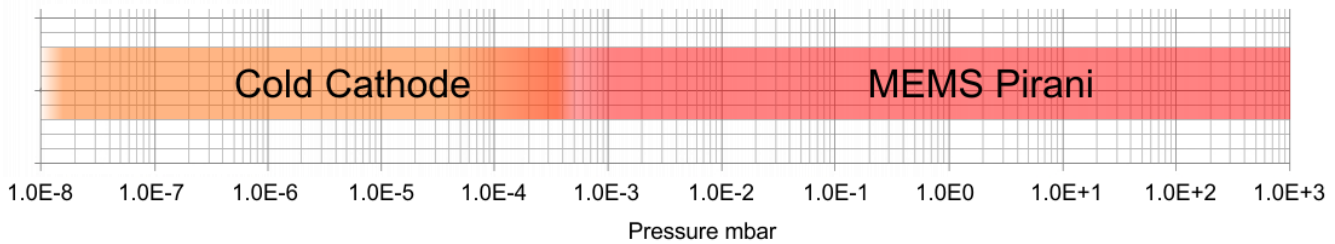

- SLC: Low CC turn on pressure (6.7×10^{-4} mbar)
- SHC: High CC turn off pressure (1.1×10^{-3} mbar)
- SLP: Low CC/MP integration (1.3×10^{-4} mbar)
- SHP: High CC/MP integration (5.3×10^{-4} mbar)

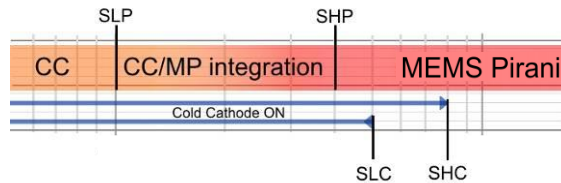

In some application it is preferred not to have the (high voltage) turned on during vacuum process or during mass spectrometer analyzing. The PTR 90 N PENNINGVAC cold cathode turn on pressure (SLC) and turn off pressure (SHC) can be changed by the user. Furthermore, the high and low integration levels between the cold cathode reading and MEMS Pirani reading can be changed by the user (see the communication protocol).



Caution



When designing external pressure control loops make sure that external equipment like pumping system is not damaged if the transmitter output enters Sensor defect mode or in case of power failure.



Caution



When designing pressure data collecting software and controlling loop make sure that the software does not interpret a communication error as a valid pressure value.

5.2 Cold Cathode Ignition

When the Cold Cathode high voltage is enabled, an ignition delay may occur. The ignition waiting time is from less than a second at high pressures to minutes at low pressures. The ignition time is a function of gas density, cleanness of the gauge and presence of any other ion sources in the system.

When the Cold Cathode is enabled, but ionization has not started, the LED-ring/LED will flash green. The LED-ring/LED will be illuminated continuously green when valid measurements are present. If the ignition has not started after 5 min, from enabling the Cold Cathode, the LED-ring/LED will turn red.

Pressure	Typical ignition time
1.00E-4 mbar	≈1 Second
1.00E-6 mbar	≈10 Seconds
≤5.00E-7 mbar	>10 Seconds

The combined analog output provides the MEMS Pirani reading until ignition has occurred and valid Cold Cathode measurements are present.

5.3 Analog output

The PTR 90 N PENNINGVAC transmitters provide a voltage output as function of pressure. The standard output is 0.6 VDC/decade but can also be configured to emulate other analog outputs.

Conversion formulae:

$$P_{\text{mbar}} = 10^{((V_{\text{out}} - 6.8)/0.6)}$$

$$V_{\text{out}} = \log_{10}(P_{\text{mbar}}) \times 0.6 + 6.8$$

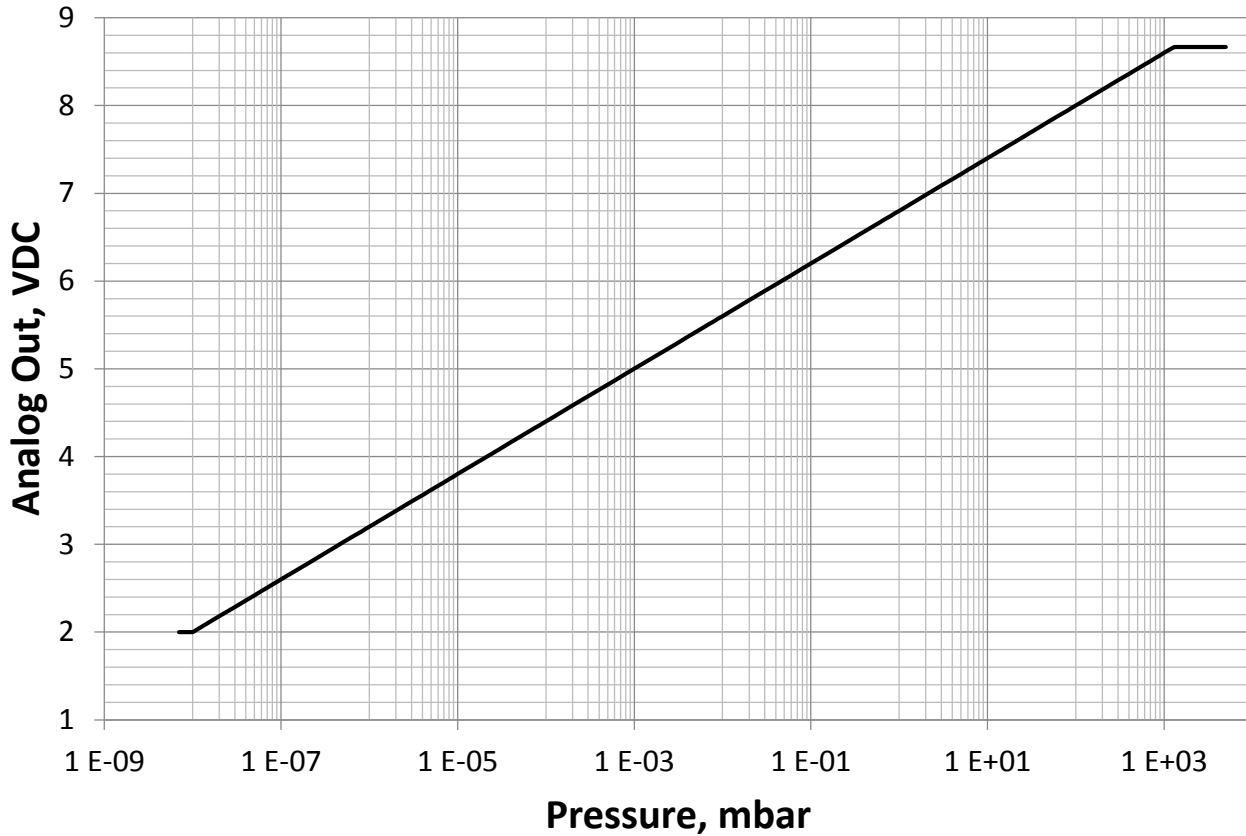

P [mbar]	Analog out [V]	P [mbar]	Analog out [V]	P [mbar]	Analog out [V]	P [mbar]	Analog out [V]	P [mbar]	Analog out [V]	P [mbar]	Analog out [V]
1,00E-08	2,000	1,00E-06	3,200	1,00E-04	4,400	1,00E-02	5,600	1,00	6,800	100,00	8,000
2,00E-08	2,181	2,00E-06	3,381	2,00E-04	4,581	2,00E-02	5,781	2,00	6,981	200,00	8,181
3,00E-08	2,286	3,00E-06	3,486	3,00E-04	4,686	3,00E-02	5,886	3,00	7,086	300,00	8,286
4,00E-08	2,361	4,00E-06	3,561	4,00E-04	4,761	4,00E-02	5,961	4,00	7,161	400,00	8,361
5,00E-08	2,419	5,00E-06	3,619	5,00E-04	4,819	5,00E-02	6,019	5,00	7,219	500,00	8,419
6,00E-08	2,467	6,00E-06	3,667	6,00E-04	4,867	6,00E-02	6,067	6,00	7,267	600,00	8,467
7,00E-08	2,507	7,00E-06	3,707	7,00E-04	4,907	7,00E-02	6,107	7,00	7,307	700,00	8,507
8,00E-08	2,542	8,00E-06	3,742	8,00E-04	4,942	8,00E-02	6,142	8,00	7,342	760,00	8,528
9,00E-08	2,573	9,00E-06	3,773	9,00E-04	4,973	9,00E-02	6,173	9,00	7,373	800,00	8,542
1,00E-07	2,600	1,00E-05	3,800	1,00E-03	5,000	1,00E-01	6,200	10,00	7,400	900,00	8,573
2,00E-07	2,781	2,00E-05	3,981	2,00E-03	5,181	2,00E-01	6,381	20,00	7,581	1000,00	8,600
3,00E-07	2,886	3,00E-05	4,086	3,00E-03	5,286	3,00E-01	6,486	30,00	7,686		
4,00E-07	2,961	4,00E-05	4,161	4,00E-03	5,361	4,00E-01	6,561	40,00	7,761		
5,00E-07	3,019	5,00E-05	4,219	5,00E-03	5,419	5,00E-01	6,619	50,00	7,819		
6,00E-07	3,067	6,00E-05	4,267	6,00E-03	5,467	6,00E-01	6,667	60,00	7,867		
7,00E-07	3,107	7,00E-05	4,307	7,00E-03	5,507	7,00E-01	6,707	70,00	7,907		
8,00E-07	3,142	8,00E-05	4,342	8,00E-03	5,542	8,00E-01	6,742	80,00	7,942		
9,00E-07	3,173	9,00E-05	4,373	9,00E-03	5,573	9,00E-01	6,773	90,00	7,973		

Analog output setup

The PTR 90 N PENNINGVAC transmitters can emulate analog voltage outputs from other vacuum transmitters. (Only for transmitters with a serial interface.) The PTR 90 N PENNINGVAC analog output can be assigned to the MEMS Pirani sensor measurement, cold cathode sensor measurement and the combined Cold cathode / MEMS Pirani reading. Refer to the Communication Protocol 300544663 (RS232) and 300544664 (EtherCAT) for analog output setup. The analog output provides 16 bit resolution.



Attention



Due to curve form and limits, some of the alternative analog outputs will cause loss of measuring range and accuracy. For best performance use the standard Oerlikon analog output. Change of analog output setup does not interfere on digital reading.

5.4 Sensor gas dependence

The PTR 90 N PENNINGVAC transmitter is based on measurement of thermal conductivity (for the MEMS Pirani-sensor) and consequently its reading depends on gas type and gas concentration. The PTR 90 N PENNINGVAC has calibration curves for a number of common gases. For gas setup refer to please refer to the Communication Protocol 300544663 (RS232) and 300544664 (EtherCAT). The sensor is per factory default calibrated for Nitrogen gas and shown below is the PTR 90 N PENNINGVAC Nitrogen MEMS Pirani reading in different gas types. Be aware that when measuring in environments where other gases than nitrogen (calibration gas) are present, the readings can deviate from the true pressure.

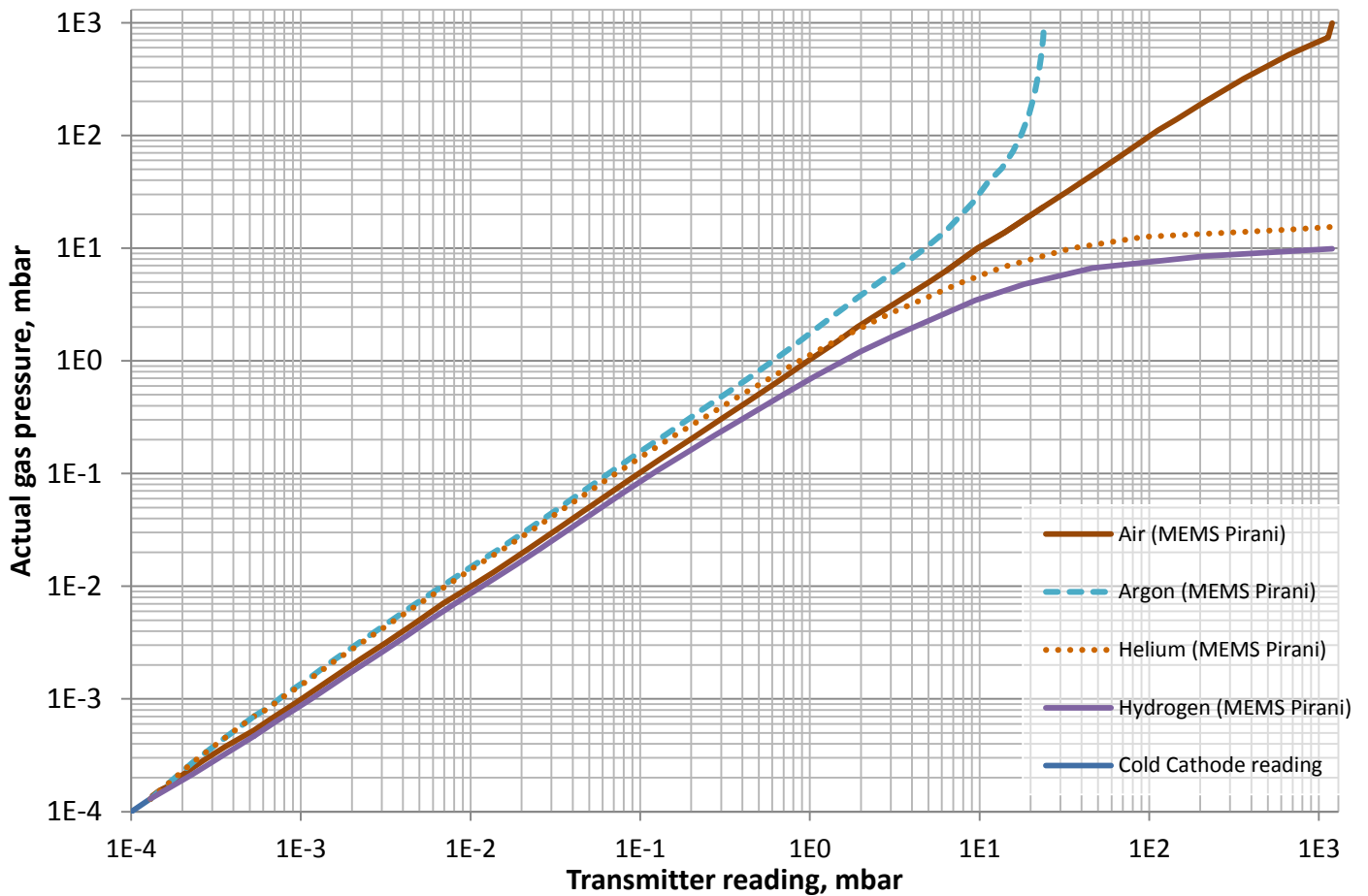

In the range below 1 mbar, the pressure indication is linear. For gases other than air, the pressure can be determined by means of a simple conversion formula:

$$p_{eff} = C \cdot \text{pressure reading}$$

For which:

Gas type	Calibration factor C	Valid range (mbar]
He	1.4	$3 \cdot 10^{-3}$ to 0.3 mbar
Ar	1.57	10^{-3} to 1 mbar
H ₂	0.84	$3 \cdot 10^{-3}$ to 0.2 mbar
Air, O ₂ , CO, N ₂	1	$3 \cdot 10^{-3}$ to 0.3 mbar

These conversion factors are average values.

6 Functions

The user switch, red/green LED-ring/LED status indicator and connector can be found at the top of the transmitter.

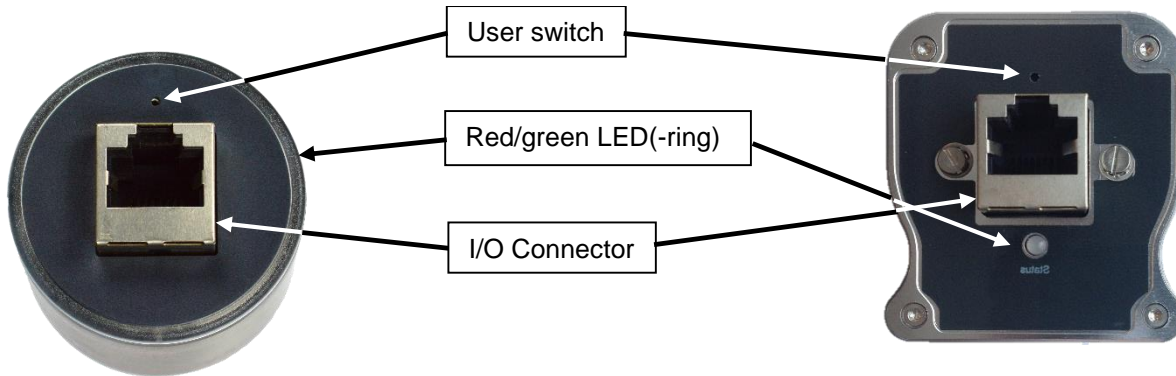

6.1 LED-ring/LED status indicator

The LED-ring/LED will indicate the status of the transmitter by showing a certain color-code:

LED-ring/LED	Transmitter status
Solid green	Normal operation
2 sec. red	Power on sequence
Green 1 sec. flash cycle	Test mode (only relevant for RS232 version)
2 sec. red	User switch disabled
Continuously RED	Transmitter defect
Off	Power off
Other	Relates to configuration of Vacuum-zero/Full-scale adjustment see chapter 6.2

The LED status indicator for transmitter versions with EtherCAT digital communication interface (P/N: 230089V02) is compliant with the EtherCAT standard, described in the Communication Protocol 300544664.

6.2 Vacuum-zero/full-scale adjustment and setpoint adjustments

Zero adjustment before operation is recommended to obtain best measurement performance in the lowest part of the measuring range.

Only for transmitter versions with RS232 digital communication interface (P/N: 230088V02) or EtherCAT digital communication interface (P/N: 230089V02) it is possible to make setpoint adjustments by using the digital communication interface. Refer to Communication Protocol 300544663 (for RS232) or Communication Protocol 300544664 (for EtherCAT) for further details.

MEMS Pirani-sensor vacuum-zero/full-scale (Zero/FS) adjustments

The vacuum-zero adjustment function changes the MEMS Pirani measurement offset at low pressure. Temporary or permanent shift in zero offset can be caused by contamination, corrosion, electrical noise interference and temperature.

The MEMS Pirani full scale adjustment allows the user to adjust the MEMS Pirani full scale reading. Vent the transmitter to atmospheric pressure using the gas that corresponds to the gas calibration setup. Full scale adjustment can only be executed with air or Nitrogen.

- **By using Auto vacuum-zero**
The MEMS Pirani will be zero adjusted whenever the pressure measured by the cold cathode is lower than 1×10^{-5} mbar. For applications that do not go below 1×10^{-5} mbar the MEMS Pirani auto zero limit can be set to higher pressure.
- **By using User switch**
It is possible to perform vacuum-zero/full-scale adjustments (Zero/FS) of the MEMS Pirani-sensor by using the user switch. See chapter 6.3.
- **By using Serial interface**
For transmitter versions with RS232 digital communication interface (P/N: 230088V02) or EtherCAT digital communication interface (P/N: 230089V02), it is possible to make vacuum-zero/full-scale (Zero/FS) adjustments using the digital communication interface. Refer to Communication Protocol 300544663 (for RS232) or Communication Protocol 300544664 (for EtherCAT) for further details.



Attention

To obtain best measuring performance, it is recommended that the transmitter is evacuated to a pressure below 1×10^{-5} mbar before executing zero adjustment of the MEMS Pirani sensor. Zero adjustment of the MEMS Pirani sensor can be executed at pressures higher than 1×10^{-5} mbar, but this can cause inaccurate readings in the lower part of the measuring range.



If the pressure measured by the transmitter is higher than approximately 1×10^{-2} mbar, then the zero adjustment cannot be executed. If the zero adjustment failed, the LED-ring/LED will flash red three times.



Attention

Zero adjustment only changes the low measuring range and will have no influence on measuring errors in the range from 1×10^{-2} mbar and above.



Full scale adjustment only changes the high measuring range and will have no influence on measuring errors in the range below 10 mbar.



Caution

Before performing the atmospheric adjustment with the user switch, vent transmitter to Nitrogen or air pressure of 1000 mbar. The transmitter will only accept full-scale adjustment when the pressure readout is within 600 to 1000 mbar. Note that if the adjustment is performed at a true pressure different from 1000 mbar, it can cause measurement deviations in the upper part of the measuring range.

Cold cathode vacuum-zero/full-scale (Zero/FS) adjustments

The cold cathode zero adjustment allows the user to adjust the cold cathode zero reading.

The cold cathode full scale adjustment allows the user to adjust the cold cathode reading at high pressure.

- **By using Serial interface**

For transmitter versions with RS232 digital communication interface (P/N: 230088V02) or EtherCAT digital communication interface (P/N: 230089V02), it is possible to make vacuum-zero/full-scale (Zero/FS) adjustments using the digital communication interface. Refer to Communication Protocol 300544663 (for RS232) or Communication Protocol 300544664 (for EtherCAT) for further details.



Attention

To obtain best measuring performance, it is recommended that the transmitter is evacuated to a pressure below 1×10^{-8} mbar before executing zero adjustment. Zero adjustment of the MEMS Pirani sensor can be executed at pressures higher than 1×10^{-8} mbar, but this can cause inaccurate reading below the zero adjustment value.



If the pressure measured by the transmitter is higher than approximately 1.3×10^{-6} mbar, then the zero adjustment cannot be executed. If the zero adjustment failed, the LED-ring/LED will flash red three times.

6.3 User switch adjustments

The user switch-button can be pressed (as seen below) by using the adjusting-pin that is added in the transmitter package or by using another pin with similar shape (\varnothing 1mm).



Attention

If the user switch is activated by accident and vacuum Zero or Full scale adjustment is executed the original factory adjustment can be recovered using the FD!VAC or FD!ATM command. Please refer to the Communication Protocol 300544663 (RS232) or Communication Protocol 300544664 (for EtherCAT) for further details.

The color of the LED-ring/LED will indicate the status of the transmitter during user switch adjustments:

Transmitter status	LED-ring/LED color
Normal operation	Solid green
Vacuum-zero/Full-scale adjustment	Pulsing between red and green

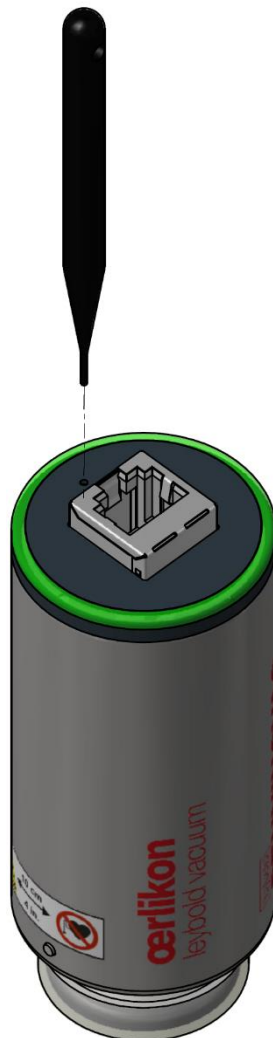

To change the transmitter from normal operation to Vacuum-zero/Full-scale adjustment-mode with the user switch, use the following guiding diagram:

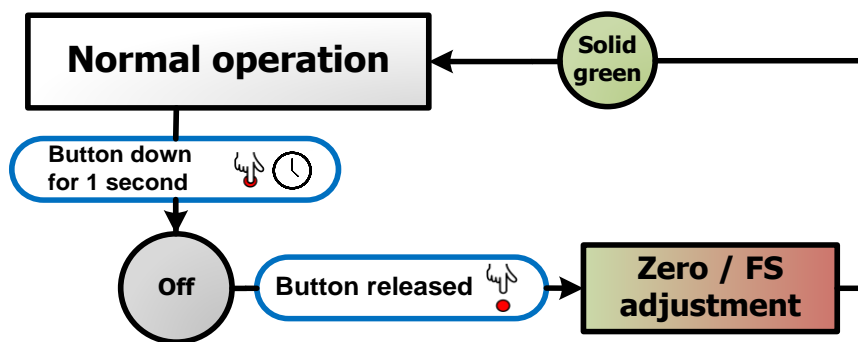

To further adjust in the Vacuum-zero/Full-scale adjustment mode, use the following guiding diagram:

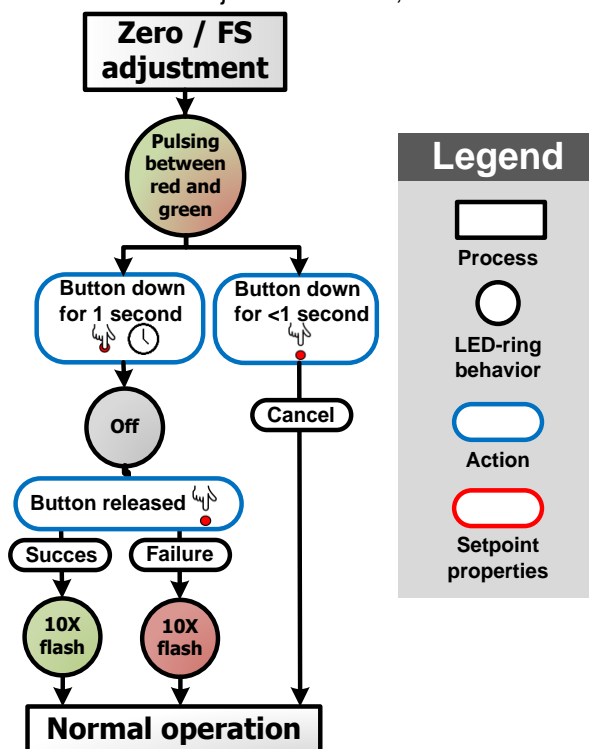

All steps from Normal operation to Vacuum-zero/Full-scale adjustment mode and related adjusting steps can also be found in the following guide:

Adjustment	User switch and LED-ring/LED action	
Zero/FS adjustment	Press button for 1 second until light ring is off	
	Release button to enter Zero/FS adjustment mode	
	Light ring is pulsing red and green	
	Press button >1 second to perform Zero/FS adjustment	Press button <1 second to go back to Normal Operation
	LED-ring/LED is off	
	Release button	
LED-ring/LED flashes green 10 times: Zero/FS adjustment succeeded	LED-ring/LED flashes red 10 times: Zero/FS adjustment failed	

6.4 Integrated touch display

For transmitter versions with integrated touch display (P/N: 230085V2) it is possible to see information about setpoints, sensors, model, and measurements unit. It is also possible to set up a pressure threshold alarm. All of this is accessible by the following menu structure:

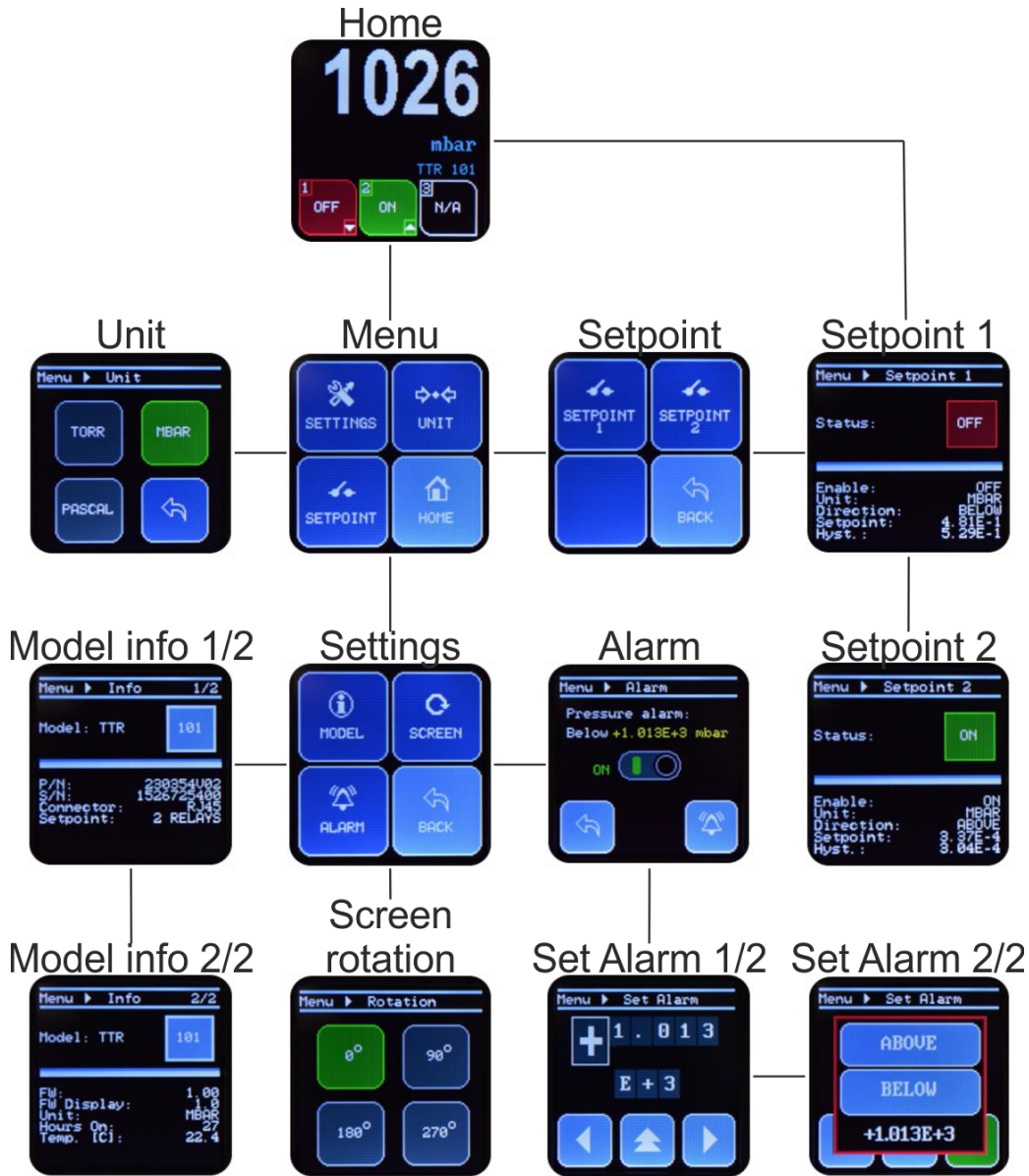

Using the integrated touch display:

When the transmitter is turned on, the initializing screen shows the transmitter name while starting up. After start-up, the screen automatically switches to the Main screen.

To access the Menu, push anywhere on the Main screen.

Screen information:

Display-screen	Information	
Start-up	Company logo and transmitter model	
Home	The Main screen shows the current pressure, the transmitter model, the status of the setpoints, the triggering direction of each setpoint and shows if an alarm is enabled. The setpoint buttons give quick access to the separate setpoint-screens.	
Menu	The general menu contains 4 buttons which lead to: Settings, Unit, Setpoint-menu and Home.	
Settings	The Settings menu contains 4 buttons which lead to: Model info, Screen rotation, Alarm and Back (to Menu)	
Setpoint menu	The Setpoint menu contains 3 buttons which lead to: Setpoint 1, Setpoint 2 and Back (to Menu)	
Setpoint screen	Setpoint 1 and 2	
	Each Setpoint screen shows the setpoint status, the pressure unit, pressure triggering direction, setpoint value and hysteresis value.	
	The setpoint status is indicated by:	
	N/A	Not Available
	X	Setpoint disabled
ON	Setpoint enabled ON	
OFF	Setpoint enabled OFF	
	If the Setpoint screen is accessed by the Setpoint menu, pressing the screen will lead back to the same menu. If accessed by the quick-access buttons on the Main screen, pressing the screen will lead back to the Main screen.	
Model info	The Model info screen shows the transmitter type and model number and each screen has different extra information. Press the screen to toggle through the different info screens.	
	Model info (1/2)	Model info (2/2)
	Transmitter P/N	Transmitter firmware version
	Serial number	Display firmware version
	Connector type	Unit
	Setpoints	Transmitter ON-time
		Temperature (°C)
Unit	Choice between Torr, Millibar or Pascal as pressure unit	
Screen rotation	The 'Screen Rotation' menu displays the current screen orientation and enables the operator to rotate the screen in four directions.	
Alarm	A visual alarm can be set at a certain pressure. Press the green or red button to enable or disable the alarm. Press Set to change the alarm pressure value and triggering direction.	
	Set Alarm (1/2)	
	Setting pressure threshold: The alarm value is set by selecting a digit (left and right arrow) and cycling through the numbers 0-9 and +/- (press up arrow or screen) To accept, press right arrow until a green checkmark appears. Press again to proceed. To cancel, press left arrow until a red arrow appears. Press again to proceed.	
	Set Alarm (2/2)	
	When the alarm is set, the operator selects whether the alarm triggers above or below the value.	

7 FAQ (Frequently Asked Questions)

Applications

Q: *Can the transmitter and sensor element continuously withstand vibrations from a mechanical fore-pump?*

A: Yes – the MEMS Pirani sensor element can withstand continuous vibrations.

Q: *Is the transmitter compatible with fluorine gases?*

A: No – The transmitter is not intended for use in aggressive environments, like semiconductor etch applications.

Q: *When the transmitter is pumped down and isolated by closing a valve the pressure is raising. Is the transmitter leaking?*

A: Not likely - when a confined space is evacuated and the pumping is stopped the pressure will rise because of outgassing, mainly by water vapor. The pressure can easily rise to a few mbar over time.

Q: *When the transmitter is leak checked on a helium leak detector. Leak reading is building up slowly after approximately 30 seconds. Is the transmitter leaking?*

A: No - the internal sealing of the PTR 90 N PENNINGVAC transmitter uses elastomer FPM sealing and consequently helium molecules can permeate through the FPM material and cause slow increase of helium leak readout. If a leaking transmitter is tested directly on a helium leak detector the leak is almost instantly displayed.

Q: *Can the transmitter be mounted in any orientation?*

A: Yes - the transmitter can be mounted in any orientation without compromise of performance or calibration. However it is recommended not to mount the transmitter with the flange port facing upwards to avoid contamination like particulates or liquids from entering the device.

Q: *Can the transmitter withstand instant ventilation?*

A: Yes - the MEMS Pirani sensor and cold cathode elements are extremely robust to mechanical forces and can withstand continuous pressure cycles and instant air ventilation.

Q: *Can I connect a valve to be controlled by the transmitter relay contact?*

A: Driving inductive loads such as valves requires special precautions. Refer to chapter 4.2.

Q: *How many pressure cycles can the transmitter withstand?*

A: Both the MEMS Pirani and cold cathode sensor elements are very mechanical robust to pressure changes and the number of pressure cycles will have no effect on the lifetime of the transmitter. In applications where fast pressure cycles occur, the cold cathode sensor can be sputtered and this can lead to change of accuracy.

Q: *The cold cathode sensor chamber has changed color, Why?*

A: If the cold cathode is operated at high pressure ($>1.00E-4$ mbar) the inside walls of the cold cathode ionization cell can be sputtered. This will change the color of the internal measuring chamber and can also result in change of measuring accuracy.

Analog output

Q: *What is the update rate of the analog output?*

A: 16 times per second.

Q: *What is the maximum length of analog output cable?*

A: The length of analog cable depends on cable quality and electrical noise environment. Cable lengths up to 100 m do not normally require any special precautions other than the cable must be screened.

Q: *The digital reading is correct but the analog output reading has some deviation from actual pressure?*

A: Check that the analog out is connected to a floating input and not an input that is connected to ground. If connected analog out return is connected to ground, the supply current will flow in the signal line and cause voltage drop and ground looping.

Q: *Can I get an analog output for the Piezo signal?*

A: Yes – the analog output can be configured to any of the sensor signals (for RS232 versions only). Refer to analog output set up.

Digital output

Q: *How fast can I request pressure measurements via the digital interface?*

A: 10 times per second is the fastest recommended pressure request frequency.

Q: *How long is the waiting time from turning power on to valid measuring values?*

A: The power on sequence is approximately 2 seconds. The light ring is illuminating red during power up sequence and the digital interface will not reply on commands. Reliable measurements for the MEMS Pirani are typically available within 1 minute. The cold cathode has a stabilization of a few minutes after turning the high voltage on.

Q: *The first character is sometimes lost in the transmitter digital communication reply?*

A: This can be caused by too fast transmitter communication reply. See RS delay command description in the Communication Protocol 300544663 (RS232).

Calibration and adjustment

Q: *How often does the transmitter require calibration or Zero adjustment?*

A: It depends on the application and pressure range but in many applications user adjustment is never required. Factors that temporarily or permanently can influence the measuring performance is contamination, corrosion, heat and electronic interference.

Q: *Will the transmitter retain user calibration after power is shut off?*

A: Yes - all transmitter parameters including calibration data are stored internally in the transmitter nonvolatile memory.

Service and repair

Q: *Can the sensor element be changed if contaminated?*

A: The cold cathode anode and cathode plates can be changed by following the procedure described in chapter 9. It is not possible to change the MEMS Pirani sensor.

Q: *A +24 VDC supply voltage has been connected to analog output+. Is the transmitter damaged?*

A: Likely - the analog output is not protected against applying power to the output pin.

Q: *Reverse voltage has been connected to power supply input. Is the transmitter damaged?*

A: Not likely – the transmitter power supply circuit has reverse voltage and over voltage protection, however, Oerlikon Leybold Vacuum cannot guarantee that the transmitter will not be damaged.

Q: *The status LED is constantly illuminating red?*

A: The red status indicates a defect MEMS Pirani sensor element most likely damaged by corrosion or contamination. It can also occur if electronics malfunction.

8 Troubleshooting

Symptom	Possible Cause/Remedy
No digital communication	<ul style="list-style-type: none"> - Check electrical connections (3 wires from transmitter to communication equipment) - Transmitter and communication equipment baud rates have to match - Use of incorrect transmitter address. Try address 254 - Attention characters missing (@) - Termination characters missing (;FF)
NAK180 is received when transmitting setpoint commands	<ul style="list-style-type: none"> - The transmitter setup is locked. Refer to disable lock procedure in the communication protocol.
Incorrect pressure value	<ul style="list-style-type: none"> - Other gas present than transmitter gas setting or trace of gas. - Contaminated sensor. Transmitter repair required. - Corroded sensor. Transmitter repair required. - Perform a zero adjustment/FS adjustment. - Check Setting of Controller or display.
Incorrect pressure value at low pressure	<ul style="list-style-type: none"> - Contaminated sensor. Transmitter repair required. - Corroded sensor. Transmitter repair required. - Incorrect zero adjustment has been executed. - Transmitter exposed to heat or cooling air stream. - Perform a zero adjustment.
Incorrect pressure value at high pressure.	<ul style="list-style-type: none"> - Contaminated sensor. Transmitter repair required. - Corroded sensor. Transmitter repair required. - Incorrect FS adjustment has been executed. - Other gas or gas trace present than transmitter gas setting. - Perform a FS adjustment.
Cold cathode does not provide measurements	<ul style="list-style-type: none"> - If the cold cathode is turned on at low pressure $<1.00E-7$ mbar or is contaminated a delay can occur from turning on high voltage to the ionization begins. At low pressure the delay can be several minutes.
Cold cathode value is lower than actual pressure	<ul style="list-style-type: none"> - If the cold cathode sensor has been operated a too high pressure or exposed to fast pressure cycles the sensor can be sputtered. Sputtering of sensor will normally provide lower reading than actual pressure.
Setpoint relay does not trip	<ul style="list-style-type: none"> - Setpoint not enabled. - Setpoint value not set to proper value. - Setpoint direction is different than the user expects. - Check electrical connection. - Check part number to see if transmitter has setpoint relays.
No analog output	<ul style="list-style-type: none"> - Power supply turned off. - Check electrical connections.
Status LED illuminating red	<ul style="list-style-type: none"> - Sensor element defect.

9 Maintenance

Transmitter failures due to contamination, as well as expendable parts (filament), are not covered by the warranty.

9.1 Cold cathode maintenance

When a cold cathode sensor is turned on and operated at pressures higher than $1E-3$ mbar the inside wall of the ionization chamber can be sputtered by ions formed by the high energetic plasma. Inert gases like argon are easier to ionize and consequently the sputter effect is more significant in such environment.

If the transmitter is contaminated, the pressure measurement will typically be lower than actual pressure. Sputtering can also be visually detected since the inside wall of the transmitter changes color. When operated in oil lubricated pumping systems, hydrocarbons can cause contamination of cold cathode measuring cell.

If sputtering or contamination occurs, the cathode plates and anode ring can be changed from the flanges side without disassembling the transmitter. The anode ring and cathode plates are available as replacement parts (See chapter 2.3). The basic accuracy of the cold cathode sensor can change after replacement of anode. The anode ring and cathode plates can also be cleaned by mechanical polishing. It is recommended to perform a zero adjustment after replacing or cleaning the cold cathode parts to achieve the best measurement performance in the lowest part of the measurement range.

Changing the cathode plates

1. Turn power off and remove cable.
2. Dismount the transmitter from the vacuum system.
3. Remove the clip ring (1) using a clip ring remove/insert tool.
4. Remove the front cathode plate (2).
5. Unscrew the Torx (T6) screw at the rear cathode plate (3).
6. Remove the rear cathode plate (3).
7. Insert the new rear cathode plate (3) (Do not touch by hand).
8. Insert the Torx (T6) screw (3) and tighten.
9. Insert the new front cathode plate (2).
10. Insert the clip ring.

Changing the anode

11. Remove the cathode plates by following step 1 to 6 in the previous guide.
12. Unscrew the 3 Torx (T6) screws at the anode module.
13. Remove the anode module and clean module or insert new.
14. Insert the anode module screw and DO NOT tighten. After all screws are inserted carefully tighten the screw a little and move on to the next one. Continue to tighten the screws one by one until all tight.
15. Perform leak testing of transmitter.
16. Insert the cathode plates by following step 7 to 10 in the previous guide.

Cleaning the cathode plates and anode

Contaminated parts can be cleaned by mechanical polishing or ultrasonic cleaned followed by alcohol degreasing (e.g. Isopropanol). Make sure that all parts are clean and remove any discoloring of the stainless steel and titanium parts. Alternatively the anode module or screens can be replaced with new parts.

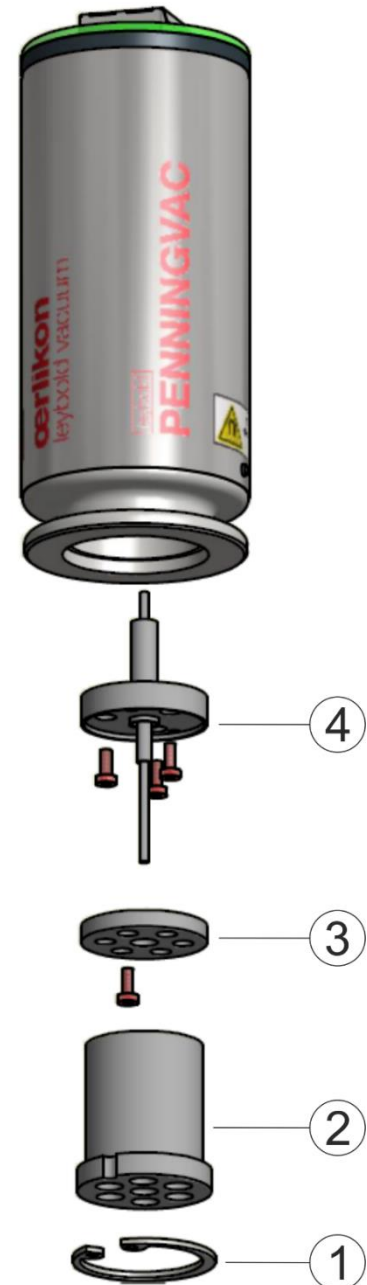

10 Declaration of Contamination

Safety information on contamination of compressors, vacuum pumps and components.

Scope:

Every employer (user) is held responsible for the health and safety of his employees. This also applies to service personnel performing maintenance work either at the premises of the user or the service company in charge.

By means of the declaration attached the contractor is to be informed about any possible contamination of the compressor, vacuum pump or component sent in for servicing. Based on this information the contractor will be able to take the necessary safety precautions.

Preparation before dispatch

Before shipping any parts, the user must complete the following declaration and add it to the dispatch papers. All dispatch instructions laid down in the manual must be followed e.g.:

- Drain all service fluids
- Remove filter elements
- Seal all openings airtight
- Pack / handle appropriately
- Attach the declaration of contamination outside of the packaging

Declaration of Contamination of Compressors, Vacuum Pumps and Components

The repair and / or servicing of compressors, vacuum pumps and components will be carried out only if a correctly completed declaration has been submitted. Non-completion will result in delay. The manufacturer can refuse to accept any equipment without a declaration.

A separate declaration has to be completed for each single component.

This declaration may be completed and signed only by authorized and qualified staff.

Customer/Dep./Institute : _____ Address : _____ _____ Person to contact: _____ Phone : _____ Fax: _____ End user: _____	Reason for return: <input checked="" type="checkbox"/> applicable please mark Repair: <input type="checkbox"/> chargeable <input type="checkbox"/> warranty Exchange: <input type="checkbox"/> chargeable <input type="checkbox"/> warranty <input type="checkbox"/> Exchange already arranged / received Return only: <input type="checkbox"/> rent <input type="checkbox"/> loan <input type="checkbox"/> for credit Calibration: <input type="checkbox"/> DKD <input type="checkbox"/> Factory-calibr. <input type="checkbox"/> Quality test certificate DIN 55350-18-4.2.1																																																																		
A. Description of the Leybold product: _____ Failure description: _____ Material description : _____ Catalog number: _____ Additional parts: _____ Serial number: _____ Application-Tool: _____ Type of oil (ForeVacuum-Pumps) : _____ Application- Process: _____																																																																			
B. Condition of the equipment <table style="width: 100%; border-collapse: collapse;"> <thead> <tr> <th style="width: 60%;"></th> <th style="width: 10%; text-align: center;">No¹⁾</th> <th style="width: 10%; text-align: center;">Yes</th> <th style="width: 10%; text-align: center;">No</th> <th style="width: 10%;"></th> <th style="width: 10%;"></th> <th style="width: 10%;"></th> </tr> </thead> <tbody> <tr> <td>1. Has the equipment been used</td> <td style="text-align: center;"><input type="checkbox"/></td> <td style="text-align: center;"><input type="checkbox"/></td> <td style="text-align: center;"><input type="checkbox"/></td> <td style="text-align: center;"><input type="checkbox"/></td> <td></td> <td></td> </tr> <tr> <td>2. Drained (Product/service fluid)</td> <td style="text-align: center;"><input type="checkbox"/></td> <td style="text-align: center;"><input type="checkbox"/></td> <td style="text-align: center;"><input type="checkbox"/></td> <td style="text-align: center;"><input type="checkbox"/></td> <td></td> <td></td> </tr> <tr> <td>3. All openings sealed airtight</td> <td style="text-align: center;"><input type="checkbox"/></td> <td style="text-align: center;"><input type="checkbox"/></td> <td style="text-align: center;"><input type="checkbox"/></td> <td style="text-align: center;"><input type="checkbox"/></td> <td></td> <td></td> </tr> <tr> <td>4. Purged</td> <td style="text-align: center;"><input type="checkbox"/></td> <td style="text-align: center;"><input type="checkbox"/></td> <td style="text-align: center;"><input type="checkbox"/></td> <td style="text-align: center;"><input type="checkbox"/></td> <td></td> <td></td> </tr> <tr> <td colspan="7"> If yes, which cleaning agent _____ and which method of cleaning _____ ¹⁾ If answered with "No", go to D. </td> </tr> </tbody> </table> <table style="width: 100%; border-collapse: collapse; margin-top: 10px;"> <thead> <tr> <th style="width: 70%;"></th> <th style="width: 10%; text-align: center;">No¹⁾</th> <th style="width: 10%; text-align: center;">Yes</th> </tr> </thead> <tbody> <tr> <td>Contamination : toxic</td> <td style="text-align: center;"><input type="checkbox"/></td> <td style="text-align: center;"><input type="checkbox"/></td> </tr> <tr> <td>corrosive</td> <td style="text-align: center;"><input type="checkbox"/></td> <td style="text-align: center;"><input type="checkbox"/></td> </tr> <tr> <td>flammable</td> <td style="text-align: center;"><input type="checkbox"/></td> <td style="text-align: center;"><input type="checkbox"/></td> </tr> <tr> <td>explosive ²⁾</td> <td style="text-align: center;"><input type="checkbox"/></td> <td style="text-align: center;"><input type="checkbox"/></td> </tr> <tr> <td>radioactive ²⁾</td> <td style="text-align: center;"><input type="checkbox"/></td> <td style="text-align: center;"><input type="checkbox"/></td> </tr> <tr> <td>microbiological ²⁾</td> <td style="text-align: center;"><input type="checkbox"/></td> <td style="text-align: center;"><input type="checkbox"/></td> </tr> <tr> <td>other harmful substances</td> <td style="text-align: center;"><input type="checkbox"/></td> <td style="text-align: center;"><input type="checkbox"/></td> </tr> </tbody> </table>			No ¹⁾	Yes	No				1. Has the equipment been used	<input type="checkbox"/>	<input type="checkbox"/>	<input type="checkbox"/>	<input type="checkbox"/>			2. Drained (Product/service fluid)	<input type="checkbox"/>	<input type="checkbox"/>	<input type="checkbox"/>	<input type="checkbox"/>			3. All openings sealed airtight	<input type="checkbox"/>	<input type="checkbox"/>	<input type="checkbox"/>	<input type="checkbox"/>			4. Purged	<input type="checkbox"/>	<input type="checkbox"/>	<input type="checkbox"/>	<input type="checkbox"/>			If yes, which cleaning agent _____ and which method of cleaning _____ ¹⁾ If answered with "No", go to D.								No ¹⁾	Yes	Contamination : toxic	<input type="checkbox"/>	<input type="checkbox"/>	corrosive	<input type="checkbox"/>	<input type="checkbox"/>	flammable	<input type="checkbox"/>	<input type="checkbox"/>	explosive ²⁾	<input type="checkbox"/>	<input type="checkbox"/>	radioactive ²⁾	<input type="checkbox"/>	<input type="checkbox"/>	microbiological ²⁾	<input type="checkbox"/>	<input type="checkbox"/>	other harmful substances	<input type="checkbox"/>	<input type="checkbox"/>
	No ¹⁾	Yes	No																																																																
1. Has the equipment been used	<input type="checkbox"/>	<input type="checkbox"/>	<input type="checkbox"/>	<input type="checkbox"/>																																																															
2. Drained (Product/service fluid)	<input type="checkbox"/>	<input type="checkbox"/>	<input type="checkbox"/>	<input type="checkbox"/>																																																															
3. All openings sealed airtight	<input type="checkbox"/>	<input type="checkbox"/>	<input type="checkbox"/>	<input type="checkbox"/>																																																															
4. Purged	<input type="checkbox"/>	<input type="checkbox"/>	<input type="checkbox"/>	<input type="checkbox"/>																																																															
If yes, which cleaning agent _____ and which method of cleaning _____ ¹⁾ If answered with "No", go to D.																																																																			
	No ¹⁾	Yes																																																																	
Contamination : toxic	<input type="checkbox"/>	<input type="checkbox"/>																																																																	
corrosive	<input type="checkbox"/>	<input type="checkbox"/>																																																																	
flammable	<input type="checkbox"/>	<input type="checkbox"/>																																																																	
explosive ²⁾	<input type="checkbox"/>	<input type="checkbox"/>																																																																	
radioactive ²⁾	<input type="checkbox"/>	<input type="checkbox"/>																																																																	
microbiological ²⁾	<input type="checkbox"/>	<input type="checkbox"/>																																																																	
other harmful substances	<input type="checkbox"/>	<input type="checkbox"/>																																																																	
C. Description of processed substances (Please fill in absolutely) 1. What substances have come into contact with the equipment ? Trade name and / or chemical term of service fluids and substances processed, properties of the substances According to safety data sheet (e.g. toxic, inflammable, corrosive, radioactive) <table border="1" style="width: 100%; border-collapse: collapse; margin-top: 5px;"> <thead> <tr> <th style="width: 5%;">X</th> <th style="width: 40%;">Tradename:</th> <th style="width: 55%;">Chemical name:</th> </tr> </thead> <tbody> <tr><td> </td><td> </td><td> </td></tr> <tr><td>a)</td><td> </td><td> </td></tr> <tr><td>b)</td><td> </td><td> </td></tr> <tr><td>c)</td><td> </td><td> </td></tr> <tr><td>d)</td><td> </td><td> </td></tr> </tbody> </table> <table style="width: 100%; border-collapse: collapse; margin-top: 10px;"> <thead> <tr> <th style="width: 60%;"></th> <th style="width: 10%; text-align: center;">No</th> <th style="width: 10%; text-align: center;">Yes</th> </tr> </thead> <tbody> <tr> <td>2. Are these substances harmful ?</td> <td style="text-align: center;"><input type="checkbox"/></td> <td style="text-align: center;"><input type="checkbox"/></td> </tr> <tr> <td>3. Dangerous decomposition products when heated ?</td> <td style="text-align: center;"><input type="checkbox"/></td> <td style="text-align: center;"><input type="checkbox"/></td> </tr> <tr> <td colspan="3">If yes, which ? _____</td> </tr> </tbody> </table> <p>²⁾ Components contaminated by microbiological, explosive or radioactive products/substances will not be accepted without written evidence of decontamination.</p>		X	Tradename:	Chemical name:				a)			b)			c)			d)				No	Yes	2. Are these substances harmful ?	<input type="checkbox"/>	<input type="checkbox"/>	3. Dangerous decomposition products when heated ?	<input type="checkbox"/>	<input type="checkbox"/>	If yes, which ? _____																																						
X	Tradename:	Chemical name:																																																																	
a)																																																																			
b)																																																																			
c)																																																																			
d)																																																																			
	No	Yes																																																																	
2. Are these substances harmful ?	<input type="checkbox"/>	<input type="checkbox"/>																																																																	
3. Dangerous decomposition products when heated ?	<input type="checkbox"/>	<input type="checkbox"/>																																																																	
If yes, which ? _____																																																																			
D. Legally binding declaration I / we hereby declare that the information supplied on this form is accurate and sufficient to judge any contamination level.																																																																			

Name of authorized person (block letters) : _____

_____ Date

_____ signature of authorized person

firm stamp

11 Declaration of Conformity

oerlikon
leybold vacuum



EC Declaration of Conformity

The manufacturer: Oerlikon Leybold Vacuum GmbH
Bonner Strasse 498, D-50968 Cologne, Germany

herewith declares that the products specified and listed below which we have placed on the market, comply with the applicable EC Council Directives.
This declaration becomes invalid if modifications are made to the product.
Compliance with the EMC Directives requires that the components are installed within a system or machine in a manner adapted to EMC requirements.

Product designation: PENNINGVAC Transmitter
Type designation: PTR 90N, PTR 200N, PTR 225N, PTR 237N, PTR 81N, PTR 82N
Catalogue No: 15734V02, 15736V02, 230070V02, 230071V02,
230072V02, 230085V02, 230087V02, 230089V02*,
89642V02, 230088V02, 230281V02, 230282V02,
230703V02*

The products complies to the following European Council Directives:

- Electromagnetic Compatibility (2004/108/EC)

The following harmonized standards have been applied:

- EN 61326-1:2013 Electrical equipment for measurement, control and laboratory use
EMC requirements – Part 1: General requirements
Immunity: controlled EM environments
- EN 55011:2009/A1:2010 Industrial, scientific and medical equipment
Radio-frequency disturbance characteristics
Limits and methods of measurement
Group 1 Class B (*Class A)

Documentation Officer: Herbert Etges
Tel: +49(0)221 347-0
Fax: +49(0)221 347-1250
E-Mail: documentation.vacuum@oerlikon.com

Cologne, dated 08.01.2016

Cologne, dated 08.01.2016

ppa. Harald Udelhoven
Head of Productline High Vacuum

ppa. Dr. Monika Mattern-Klosson
Head of Quality Management

12 Notes

13 Sales and Service

Germany

Oerlikon Leybold Vacuum GmbH
Sales, Service, Support Center (3SC)
Bonner Strasse 498
D-50968 Cologne
Phone: +49-(0)221-347 1234
Fax: +49-(0)221-347 31234
sales.vacuum@oerlikon.com
www.oerlikon.com/leyboldvacuum

Oerlikon Leybold Vacuum GmbH
Sales Area North
Branch Office Berlin
Industriestrasse 10b
D-12099 Berlin
Phone: +49-(0)30-435 609 0
Fax: +49-(0)30-435 609 10
sales.vacuum.bn@oerlikon.com

Oerlikon Leybold Vacuum GmbH
Sales Office South
Branch Office Munich
Karl-Hammerschmidt-Strasse 34
D-85609 Aschheim-Dornach
Phone: +49-(0)89-357 33 9-10
Fax: +49-(0)89-357 33 9-33
sales.vacuum.mn@oerlikon.com
service.vacuum.mn@oerlikon.com

Oerlikon Leybold Vacuum
Dresden GmbH
Service Competence Center
Zur Wetterwarte 50, Haus 304
D-01109 Dresden
Service:
Phone: +49-(0)351-88 55 00
Fax: +49-(0)351-88 55 041
info.vacuum.dr@oerlikon.com

Europe

Belgium

Oerlikon Leybold Vacuum
Nederland B.V.
Belgisch bijkantoor
Leuvensesteenweg 542-9A
B-1930 Zaventem
Sales:
Phone: +32-2-711 00 83
Fax: +32-2-720 83 38
sales.vacuum.zv@oerlikon.com
Service:
Phone: +32-2-711 00 82
Fax: +32-2-720 83 38
service.vacuum.zv@oerlikon.com

France

Oerlikon Leybold Vacuum
France S.A.S.
Parc du Technopolis, Bâtiment Beta
3, Avenue du Canada
F-91940 Les Ulis cedex
Sales and Service:
Phone: +33-1-69 82 48 00
Fax: +33-1-69 07 57 38
info.vacuum.ctb@oerlikon.com
sales.vacuum.ctb@oerlikon.com

Oerlikon Leybold Vacuum
France S.A.S.
Valence Factory
640, Rue A. Bergès
B.P. 107
F-26501 Bourg-lès-Valence Cedex
Phone: +33-4-75 82 33 00
Fax: +33-4-75 82 92 69
marketing.vacuum.vc@oerlikon.com

Great Britain

Oerlikon Leybold Vacuum
UK LTD.
Unit 9
Silverglade Business Park
Leatherhead Road
Chessington
Surrey (London)
KT9 2QL
Sales:
Phone: +44-13-7273 7300
Fax: +44-13-7273 7301
sales.vacuum.ln@oerlikon.com
Service:
Phone: +44-13-7273 7320
Fax: +44-13-7273 7303
service.vacuum.ln@oerlikon.com

Italy

Oerlikon Leybold Vacuum
Italia S.r.l.
Via Trasimeno 8
I-20128 Mailand
Sales:
Phone: +39-02-27 22 31
Fax: +39-02-27 20 96 41
sales.vacuum.mi@oerlikon.com
Service:
Phone: +39-02-27 22 31
Fax: +39-02-27 22 32 17
service.vacuum.mi@oerlikon.com

Netherlands

Oerlikon Leybold Vacuum
Nederland B.V.
Floridadreef 102
NL-3565 AM Utrecht
Sales and Service:
Phone: +31-(30) 242 63 30
Fax: +31-(30) 242 63 31
sales.vacuum.ut@oerlikon.com
service.vacuum.ut@oerlikon.com

Switzerland

Oerlikon Leybold Vacuum
Schweiz AG, Pfäffikon
Churerstrasse 120
CH-8808 Pfäffikon
Warehouse and shipping address:
Riedthofstrasse 214
CH-8105 Regensdorf
Sales:
Phone: +41-44-308 40 50
Fax: +41-44-302 43 73
sales.vacuum.zh@oerlikon.com
Service:
Phone: +41-44-308 40 62
Fax: +41-44-308 40 60
service.vacuum.zh@oerlikon.com

Spain

Oerlikon Leybold Vacuum
Spain, S.A.
C/ Huelva, 7
E-08940 Cornellà de Llobregat
(Barcelona)
Sales:
Phone: +34-93-666 43 11
Fax: +34-93-666 43 70
sales.vacuum.ba@oerlikon.com
Service:
Phone: +34-93-666 46 11
Fax: +34-93-685 43 70
service.vacuum.ba@oerlikon.com

America

USA

Oerlikon Leybold Vacuum
USA Inc.
5700 Mellon Road
USA-Export, PA 15632
Phone: +1-724-327-5700
Fax: +1-724-325-3577
info.vacuum.ex@oerlikon.com
Sales:
Phone: +1-724-327-5700
Fax: +1-724-333-1217
Service:
Phone: +1-724-327-5700
Fax: +1-724-325-3577

Brazil

Oerlikon Leybold Vacuum
Brasil
Rod. Vice-Prefeito Hermenegildo Tonolli,
nº. 4413 - 6B
Distrito Industrial
Jundiaí - SP
CEP 13.212-315
Sales and Service:
Phone: +55 11 2152 0499
Fax: +55 11 99467 5934
sales.vacuum.ju@oerlikon.com
service.vacuum.ju@oerlikon.com

Asia

P. R. China

Oerlikon Leybold Vacuum (Tianjin)
International Trade Co. Ltd.
Beichen Economic
Development Area (BEDA),
No. 8 Western Shuangchen Road
Tianjin 300400
China
Sales and Service:
Phone: +86-22-2697 0808
Fax: +86-22-2697 4061
Fax: +86-22-2697 2017
sales.vacuum.tj@oerlikon.com
service.vacuum.tj@oerlikon.com

India

Oerlikon Leybold Vacuum
India Pvt Ltd.
No. 82(P), 4th Phase
K.I.A.D.B. Plot
Bommasandra Industrial Area
Bangalore - 560 099
India
Sales and Service:
Phone: +91-80-2783 9925
Fax: +91-80-2783 9926
sales.vacuum.bgl@oerlikon.com
service.vacuum.bgl@oerlikon.com

Japan

Oerlikon Leybold Vacuum
Japan Co., Ltd.
Headquarters
Shin-Yokohama A.K.Bldg., 4th floor
3-23-3, Shin-Yokohama
Kohoku-ku, Yokohama-shi
Kanawaga 222-0033
Japan
Sales:
Phone: +81-45-471-3330
Fax: +81-45-471-3323
info.vacuum.yh@oerlikon.com
sales.vacuum.yh@oerlikon.com

Oerlikon Leybold Vacuum
Japan Co., Ltd.
Tsukuba Technical Service Center
1959, Kami-yokoba
Tsukuba-shi, Ibaraki-shi 305-0854
Japan
Service:
Phone: +81-29 839 5480
Fax: +81-29 839 5485
service.vacuum.iik@oerlikon.com

Malaysia

Oerlikon Leybold Malaysia
Oerlikon Leybold Vacuum
Singapore Pte Ltd.
No. 1 Jalan Hi-Tech 2/6
Kulim Hi-Tech Park
Kulim, Kedah Darul
Aman 09000
Malaysia
Sales and Service:
Phone: +604 4020 222
Fax: +604 4020 221
sales.vacuum.ku@oerlikon.com
service.vacuum.ku@oerlikon.com

South Korea

Oerlikon Leybold Vacuum
Korea Ltd.
3F. Jellzone 2 Tower
Jeongja-dong 159-4
Bundang-gu Sungnam-si
Gyeonggi-do
Bundang 463-384, Korea
Sales:
Phone: +82-31 785 1367
Fax: +82-31 785 1359
sales.vacuum.bd@oerlikon.com
Service:
623-7, Upsung-Dong
Cheonan-Si
Chungcheongnam-Do
Korea 330-290
Phone: +82-41 589 3035
Fax: +82-41 588 0166
service.vacuum.cn@oerlikon.com

Singapore

Oerlikon Leybold Vacuum
Singapore Pte Ltd.
8 Commonwealth Lane #01-01
Singapore 149555
Singapore
Sales and Service:
Phone: +65-6303 7030
Fax: +65-6773 0039
sales.vacuum.sg@oerlikon.com
service.vacuum.sg@oerlikon.com

Taiwan

Oerlikon Leybold Vacuum
Taiwan Ltd.
No 416-1, Sec. 3
Chunghsin Rd., Chutung
Hsinchu County 310
Taiwan, R.O.C.
Sales and Service:
Phone: +886-3-500 1688
Fax: +886-3-583 3999
sales.vacuum.hc@oerlikon.com
service.vacuum.hc@oerlikon.com

Oerlikon
Leybold Vacuum GmbH
Bonner Strasse 498
D-50968 Cologne
Phone: +49-(0)221-347 0
Fax: +49-(0)221-347 1250
info.vacuum@oerlikon.com

oerlikon
leybold vacuum
www.oerlikon.com/
leyboldvacuum