

***Turbomolecular Drag Pumps
With Electronic Drive Unit TC 600***



TMH 071 P

TMU 071 P

PM 800 504 BE/G (0205)

	Page		Page
1. Safety Instructions.....	3	5. Monitoring Operations.....	16
1.1. For Your Orientation.....	3	5.1. Operations Display Via LED.....	16
1.2. Pictogram Definitions.....	3	5.2. Turbopump Temperature Management.....	16
2. Understanding The Pumps TMH 071 P/TMU 071 P	4	6. What To Do In Case Of	17
2.1. Main Features.....	4	6.1. Breakdowns ?.....	17
Proper Use	4	7. Maintenance.....	18
Improper Use	4	7.1. Replacing The Lubricant Reservoir.....	18
2.2. Differences Between The Pump Types.....	4	8. Service.....	19
3. Installation	5	9. Technical Data.....	20
3.1. Preparations For Installation.....	5	9.1. Dimensions Diagram	21
3.2. Installing The Pump, Connecting The High Vacuum Side	5	10. Spare Parts.....	22
Fitting The Splinter Shield.....	6	11. Accessories	23
3.3. Connecting The Fore-Vacuum Side	6	Declaration of Contamination	24
3.4. Connecting The Cooling Unit.....	7	Manufacturer's Declaration	(last page)
3.5. Connecting The Venting Valve.....	7		
3.6. Connecting The Casing Heating Unit.....	7		
3.7. Connecting The Sealing Gas Valve.....	7		
3.8. Connecting The Electronic Drive Unit TC 600.....	8		
3.9. Installing The Power Unit	8		
3.10. Connecting The Remote Control Unit	9		
3.11. Connecting The Serial Interface RS 485	10		
Connection	10		
Connecting The RS 485	10		
3.12. Connections Diagram.....	11		
4. Operations.....	12		
4.1. Before Switching ON.....	12		
4.2. Switching ON.....	12		
4.3. Switching OFF And Venting.....	13		
4.4. Operations With The DCU 001/DCU 100	13		
4.5. Gas Type Dependent Operations	13		
4.6. Shutting Down For Longer Periods	14		
4.7. Operations With The Remote Control Unit.....	14		
Venting Release (Optional).....	14		
Motor, Turbopump	14		
Pumping Station	15		
Heating/Reset	15		
Standby.....	15		
Rotation Speed Setting Mode Via Input PWM	15		
Switching Outputs.....	15		

Please note: Current operating instructions are available via www.pfeiffer-vacuum.de under "Infoservice".

1. Safety Instructions

- ☞ Read and follow all instructions in this manual.
- ☞ Inform yourself regarding:
 - Hazards which can be caused by the pump;
 - Hazards which can be caused by your system.
 - Hazards which can be caused by the media being pumped.
- ☞ Avoid exposing any part of the body to vacuum.
- ☞ Observe the safety and accident prevention regulations.
- ☞ Regularly check that all accident prevention measures are being complied with.
- ☞ Do not operate the turbopump with open high vacuum flange.
- ☞ Do not carry out any unauthorised conversions or alterations to the turbopump with TC 600.
- ☞ When returning the turbopump observe the shipping instructions.
- ☞ Use at least 4 bracket screws to connect the high vacuum flange (ISO-flange).
- ☞ The turbopump must be anchored in accordance with the installation instructions.
- ☞ Do not disconnect the plug between the TC 600 and accessory components during operations.
- ☞ Disconnect the voltage supply to the TC 600 before opening the turbopump.
- ☞ When working on the turbopump, the high vacuum flange should only be opened once the rotor is at rest.
- ☞ When using sealing gas, the pressure in the hose connection should be limited to 2 bar via the overpressure valve.
- ☞ If a heater is in use temperatures of up to 120 °C can be present in the area of the high vacuum flange. Take care to avoid burns !
- ☞ During operations, temperatures of up to 65 °C can arise in the lower part of the turbopump. Take care to avoid burns!
- ☞ Keep leads and cables well away from hot surfaces (> 70 °C).
- ☞ Operate the turbopump with TC 600 only in conjunction with the relevant power unit (accessory).
- ☞ The unit has been accredited protection class IP 30. When the unit is operated in environments which require other protection classes, the necessary measures must be taken. Protection class IP 54 is afforded by retro-fitting a cover plate (Accessory) to the TC 600.
- ☞ The mains connection must be subject to a safe connection to the PE (protection class 1).
- ☞ If the turbopump and the TC 600 are operated independently of each other (only permissible with the agreement of the manufacturer) the turbopump must be connected to the PE.
- ☞ The turbopump and the TC 600 must only be disconnected from each other when the turbopump is completely at rest and the TC 600 has been disconnected from the power supply.
- ☞ The cause of any operating voltage leakage to earth (red LED flashes) must be eliminated to avoid the danger of an electric shock.

Modifications reserved.

1.1. For Your Orientation

Instruction in the text

➔ Working instruction: here, you have to do something.

Symbols used

The following symbols are used throughout in all illustrations.

- ⓘ High vacuum flange
- Ⓜ Fore-vacuum flange
- Ⓟ Venting connection
- Ⓢ Cooling water connection
- Ⓣ Air cooling
- Ⓛ Electric connection
- Ⓢ Sealing gas connection

Abbreviations used

DCU = Operating and display control unit

TC = Electronic drive unit, turbopump

TPS = Power Unit

Position numbers

The same pump and accessory parts have the same position numbers in all illustrations.

1.2. Pictogram Definitions



Danger of burns from touching hot parts.



Danger of personal injury.



Danger of damage to the pump or to the system.



Danger of injury from rotating parts.



Attention to particularly important information on the product, handling the product or to a particular part of the documentation.

2. Understanding The Pumps TMH 071 P/TMU 071 P

2.1. Main Features

Turbopumps TMH 071 P/TMU 071 P with the TC 600 form a complete unit. Voltage is supplied by the power unit (see "Accessories").



On delivery, the pumps have been set up for operations in remote mode. Remote plug 8d should therefore be disconnected if operations with the DCU are required.

Turbomolecular Drag Pump TMH 071 P/TMU 071 P

- 1 High vacuum flange
- 2 Fore-vacuum flange
- 4 Venting Valve
- 6 Rubber feet
- 8 Electronic Drive Unit TC 600
- 8d Remote plug

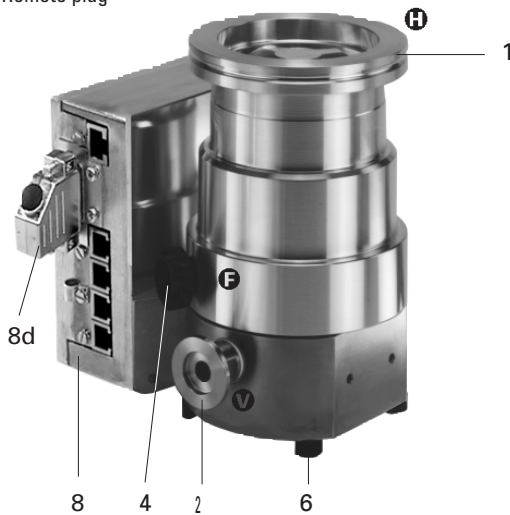

Cooling

- Enhanced convection cooling with cooling unit (accessory),
- air cooling (accessory) or
- water cooling (accessory).

Integrated protective measures against excess temperatures:
The Electronic Drive Unit TC 600 reduces the rotor rotation speed.

Bearings

High vacuum side: Wear free permanent magnetic bearing.
Fore-vacuum side: Oil circulatory lubricated ball bearing with ceramic balls.

Proper Use

- The Turbomolecular Pumps TMH 071 P/TMU 071 P may only be used for the purpose of generating vacuum.
- The turbopumps may only be used to pump those media against which they are chemically resistant. For other media the operator is required to qualify the pumps for the processes involved.

- If the process produces dust, the maintenance intervals must be specified accordingly and sealing gas must be used.
- The turbopump must be connected to a backing pump in accordance with Section 3.3.
- Only PFEIFFER power units may be used to operate the TC 600. The use of other power units requires the prior agreement of the manufacturer and equalization with the valid specification.
- The pumps may only be operated providing the ambient conditions in compliance with Protection Type IP 30 are observed.

Improper Use

The following is regarded, inter alia, as improper:

- The pumping of explosive or corrosive gases.
- Operating the pumps in areas where there is a danger of explosion.
- The pumping of gases and vapours which attack the materials of the pumps.
- The pumping of corrosive gases without sealing gas.
- The pumping of condensating vapours.
Operations involving impermissibly high levels of gas loads.
- Operations with improper gas modes.
- Operations involving too high levels of heat radiation power (see Section 9. "Technical Data").
- Operations without the use of cooling equipment.
- Operating the pump in environments which require a protection class superior to IP 30.
- The use of other power units or accessories which are not named in this manual or which have not been agreed by the manufacturer.
- The connection to power units with earthing of a direct voltage pole.

Improper use will cause all claims for liability and guarantees to be forfeited.

2.2. Differences Between The Pump Types

Feature	TMH 071 P	TMU 071 P
High vacuum flange	ISO-KF / ISO-K	CF-F
High vacuum seal	Viton	Metal
Attainable final pressure	$< 1 \cdot 10^{-7}$ mbar (without baking-out)	$< 5 \cdot 10^{-10}$ mbar (with baking-out)

Abbreviations on the type of the pump

Suffix "P": Purge gas connection for the prevention of the ingress of aggressive gases into the motor and bearing arena.

3. Installation

3.1. Preparations For Installation



Do not carry out any unauthorised conversions or alterations to the turbopump.

- The maximum permissible rotor temperature of the pump is 90 °C. If the vacuum chamber or parts in the vacuum chamber are heated must be fitted if necessary, suitable shielding in the vacuum chamber before the turbopump (constructional suggestions available on request).
- Only remove the blank flange from the high and fore-vacuum side immediately before connection.
- On Turbopumps TMH 071 P/TMU 071 P the lubricant reservoir is already fitted and filled.
- Where magnetic fields of > 4 mT are involved suitable shielding must be provided (available on request).
- If the pump is baked out, the heating sleeve and the body of the pump must be insulated to prevent burns from accidental contact.
- In the event of a sudden standstill of the rotor, torques of up to 330 Nm can arise and these must be taken up by the turbopump and frame. Pumps must be anchored as follows:
 - ISO flange with 4 bracket screws, or
 - CF flange with the complete set of M8 screws, or
 - Underside of the pump with 4 screws M5, screws quality 8.8.
- Either air or water cooling is necessary for operating the pump. Where operations with convection cooling are involved, a cooling unit must be used (please see "Accessories")

3.2. Installing The Pump, Connecting The High Vacuum Side



The utmost cleanliness must be observed when fitting all high vacuum parts. Unclean components prolong the pumping time.

Using the splinter shield

The use of a splinter shield in the high vacuum flange protects the turbopump against foreign bodies coming from the vacuum chamber but does reduce the volume flow rate of the pump by approximately 15%.

For fitting splinter shields please refer to "Fitting the splinter shield".

The high vacuum side can be flanged onto the the vacuum chamber directly or via a PFEIFFER bellows or a vibration compensator (see "Accessories").

Connecting via a bellows

If the high vacuum side is to be flanged via a bellows, the turbopump must be secured for example via the holes on the underside of the turbopump must be secured for example via the holes on the underside of the pump. The fastening must be able to withstand the torque referred to in Section 3.1.

Connecting via a PFEIFFER vibration compensator

Where a PFEIFFER vibration compensator is in use, a freely suspended turbopump can be flanged onto the vacuum chamber. Additional fastening is unnecessary.



The maximum permissible temperature at the vibration compensator is 100 °C.

Directly flanging the pump

The turbopump can be flanged onto the vacuum chamber vertically (0°) up to an angle of 90° maximum.



The fore-vacuum flange must always point downwards.

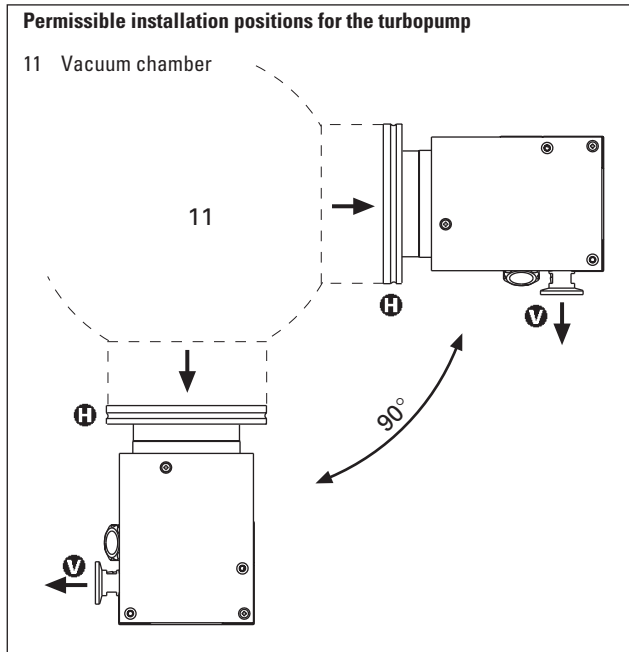

The maximum loading capacity of the high vacuum flange is 200 N (equivalent to 20 kg). Asymmetric loading on the high vacuum flange must be avoided.

With horizontal pump installation and oil-sealed backing pumps (e.g. rotary vane pumps) the fore-vacuum flange of the turbopump must be aligned vertically downwards (maximum deviation $\pm 20^\circ$), otherwise the turbopump could become dirty.

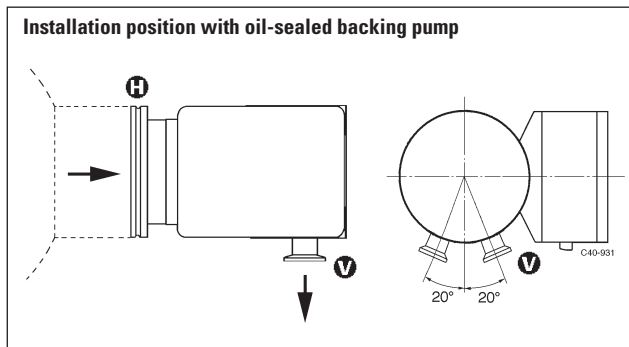

No forces from the piping system must be allowed to act on the pump where turbopumps are anchored. Suspend or support all pipes to the pump.

Fitting The Splinter Shield

Insert the splinter shield in the high vacuum flange in such a way that the corrugation of the strainer points outwards.

DN 63

- ➔ Bend the clamping lugs slightly outwards so that subsequently the splinter shield is seated firmly in the high vacuum flange (to avoid noise).
- ➔ Insert the splinter shield in the high vacuum flange while pressing the clamping lugs slightly inwards.
- ➔ Press the outer ring of the splinter shield up to the limit stop point in the high vacuum flange.

DN 40

- ➔ Insert the splinter shield up to the limit stop point in the high vacuum flange (bend not the clamping lugs outwards).

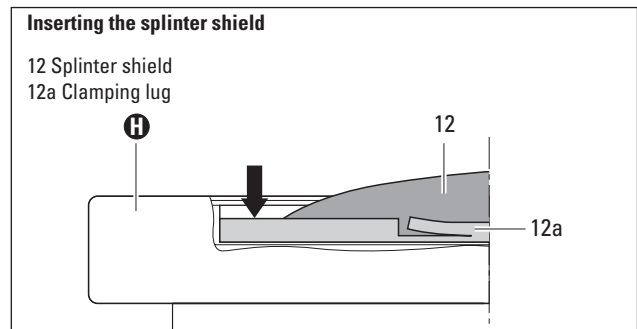

3.3. Connecting The Fore-Vacuum Side

Backing pump: Vacuum pressure ≤ 10 mbar
 Recommendation: Oil-Free Diaphragm Pump or Rotary Vane Vacuum Pumps from the PFEIFFER range (note installation position, turbopump, see Section 3.2.).

Connecting the backing pump

All connections of the fore-vacuum line: with the usual small flange components or hose screw connections.



Be sure to conduct away the exhaust gases from the backing pump. Do not reduce the free cross section of the fore-vacuum flange with following components.



The exhausted process gases and vapours can represent a health hazard and can also be environmentally damaging. Comply with all the gas manufacture's safety instructions.

- ➔ With rigid pipe connections: fit a bellows in the connecting line to reduce vibration.
- ➔ The electrical connection of the backing pump is made via a relay box whose control line is connected to "FV PUMP" on the TC 600.

Please refer to Operating Instructions PT 800 030 BN for details on the relay box, backing pump and its installation.

3.4. Connecting The Cooling Unit

Turbopumps TMH 071 P/TMU 071 P can optionally be provided with enhanced convection cooling, air cooling or water cooling.

The turbopumps must be operated with air or water cooling where the fore-vacuum pressure is increased (> 0.1 mbar) and/or operations with gas loads.

Use and installation:

- For water cooling please refer to Operating Instructions PM 800 546 BN.
- For air cooling please refer to Operating Instructions PM 800 543 BN.
- Permissible installation positions for the cooling unit where convection cooling is involved please see Section 9.1. "Dimensions Diagram".

3.5. Connecting The Venting Valve

The Venting Valve TVF 005 provides automatic venting in the event of a power failure and switching off.

Fitting the venting valve

- ➔ Unscrew the venting screw from the venting connection of the turbopump.
- ➔ Screw in venting valve 42 with seal (USIT ring) on hexagonal SW 14.

Electrical connection

- ➔ Plug control lead 42a into the connection "VENT" of the TC 600 (8) on the turbopump.

The venting mode of the venting valve is selected via the DCU or Serial Interface RS 485.

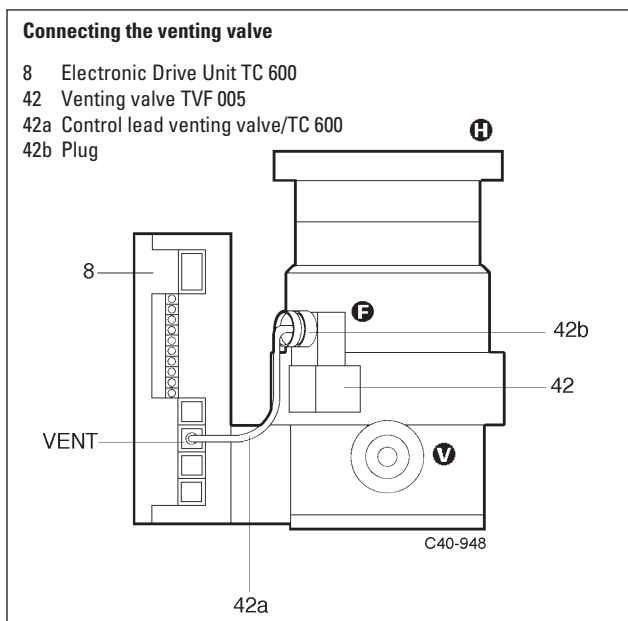

The maximum pressure at the venting valve is 1.5 bar absolute.

Please refer to Operating Instructions PM 800 507 BN for details on Venting Valve TVF 005.

3.6. Connecting The Casing Heating Unit

The attainment of final pressures is accelerated when turbopumps and vacuum chambers are baked out.

The heating duration is dependent on the degree of dirt and on the required final pressure level. The heating duration should be at least 4 hours.



Where casing heating is involved the turbopump must be water cooled.



High temperatures are generated when the turbopump is baked out. There is a danger of burns resulting from touching hot parts, even after the casing heating has been switched off. Ideally, the heating sleeve and the pump casing should be insulated during installation. Do not touch the heating sleeve and the pump casing during the baking out process.

Please refer to Operating Instructions PM 800 542 BN for details on the casing heating unit and its installation.

3.7. Connecting The Sealing Gas Valve

To protect the pump, particularly where corrosive or dust producing processes are involved, it is necessary to use sealing gas.

Connection is made via the sealing gas valve (please see "Accessories").

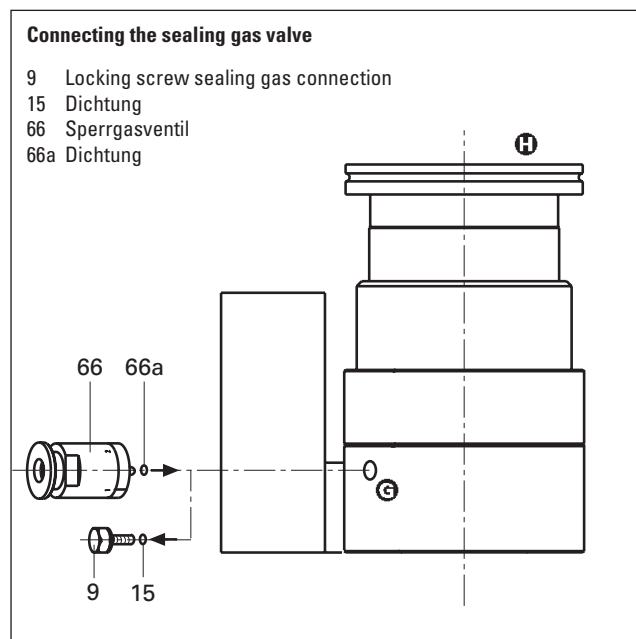

Please refer to Operating Instructions PM 800 229 BN for details on installing the sealing gas valve and adjusting the sealing gas flow.

3.8. Connecting The Electronic Drive Unit TC 600



The turbopump and the Electronic Drive Unit TC 600 are connected and together form a single unit.
Connecting cable 8a has to be ordered separately (see "Accessories").

- ➔ Unscrew screw with tooth lock 8c from the TC 600 (above the connection X4).
- ➔ Plug the plug X4 on connecting cable 8a into the connection X4 on the TC 600 and screw in screw 8b.
- ➔ Secure plug X4 on the TC 600 with a screw and tooth lock 8c.
- ➔ Connect plug X2 on connecting cable 8a with power unit TPS 100/DCU 100 ("Accessories") on connection X2.
- ➔ Using screws and toothlock 8c (two pieces, included with the cable consignment) secure plug X2 to power unit 105.



Once operations voltage has been supplied, the TC 600 performs a self test on the supply voltage. The supply voltage for Turbomolecular Pumps TMH 071 P/TMU 071 P is 24 VDC \pm 5% in accordance with EN 60 742.

If the turbopump is being operated with the Operations And Display Unit DCU 001/100, remote plug 8d should be disconnected. Connection should be carried out in accordance with Operating Instructions PM 800 477 BN.

3.9. Installing The Power Unit



Voltage may only be supplied with the PFEIFFER power units (Accessory). The use of other power units requires the prior agreement of the manufacturer and equalization with the valid specification (power unit specifications available on request).

Please refer to Operating Instructions PM 800 521 BN for details on Power Unit TPS 100.

Connecting the TC 600 with Power Unit TPS 100/DCU 100

- X1 Mains connection
- X2 Connection, power unit
- X4 Connection TC 600
- S1 ON/OFF switch
- 8 Electronic Drive Unit TC 600
- 8a Connecting cable, TC 600 – TPS/DCU
- 8b Screw
- 8c Screw with tooth lock (3 pieces)
- 8d Remote plug
- 105 Power unit

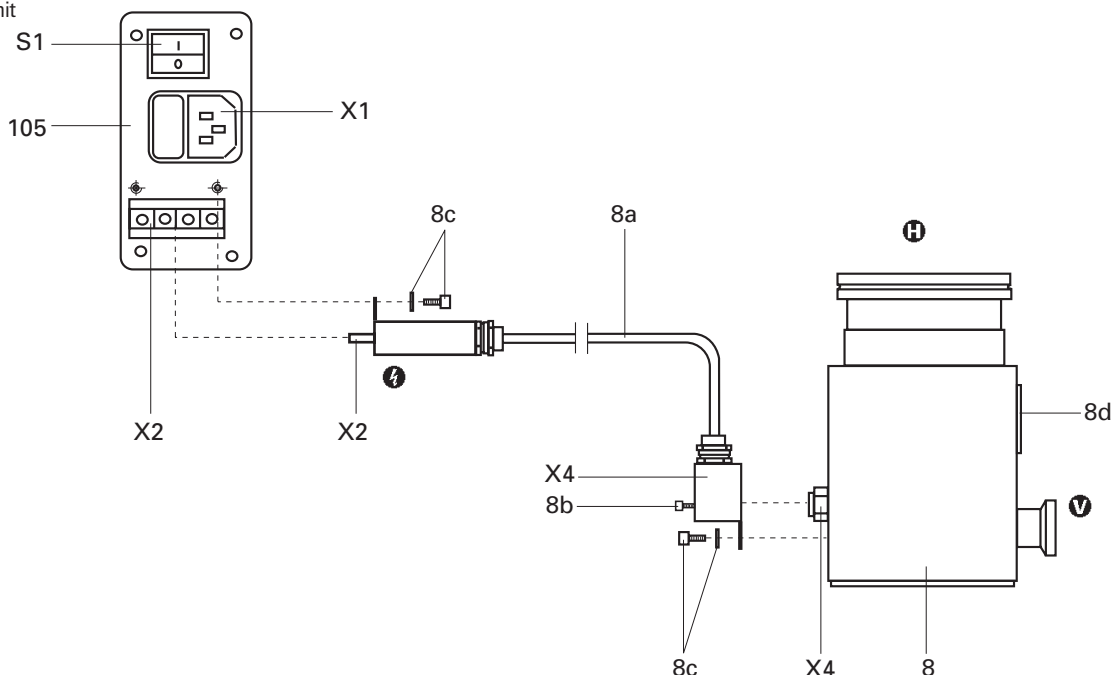

3.10. Connecting The Remote Control Unit

Remote control options for various functions are provided with the connection "REMOTE" on the TC 600 via the 15-pole D-Sub-Connector. Shielded cable must be used. Shielding is on the plug side of the TC 600 connected to the TC casing.

The inputs 2-6 are activated by connecting them to the + 24 V on pin 1 (active high) (please see "Connection Diagram").

Pin occupancy and remote plug functions
(please see following table)



When connecting supply voltage, the turbopump is started.

On delivery:

Pin 1, Pin 2, Pin 3 and Pin 4 are bridged in the mating plug.

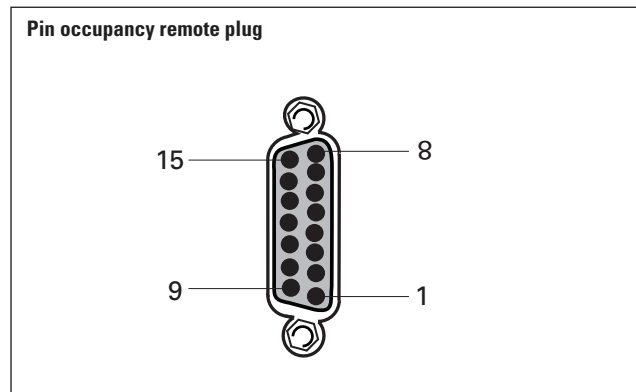

Pin occupancy and remote plug functions		
Pin nr.	Input open (low)	Input closed (high) on + 24V (pin 1)
1	+24 V	
2	venting blocked (see Section 3.5.)	venting released (see Section 3.5.)
3	motor, turbopump off	motor, turbopump on: the turbopump is driven, current flows through the motor coils
4	pumping station off	pumping station on: the turbopump is driven, backing pump is started via the relay box
5	heating off	heating on: the heating is switched on once the rotation speed switchpoint is attained and off when the rotation speed switchpoint is unattained
5		reset: by supplying a pulse (T < 2s) with an amplitude of 24V a malfunction acknowledgement can be processed
6	standby off	standby on: pump is accelerated to 66% of its nominal rotation speed
7	rotation speed setting mode off	the rotation speed can be changed by feeding a PWM signal to this pin or via Serial Interface RS 485 (see Section 4.7. "Rotation Speed Setting Mode")
8	Output (low) rotation speed switchpoint not attained	Output (high) rotation speed switchpoint attained; output can be loaded with 24 V/50 mA
9	Output (low) Collective malfunction message	Output (high) malfunction-free operations; output can be loaded with 24 V/50 mA
10	Mass (ground)	_____
11	Contact Output 1: Switchpoint attained	contact ¹⁾ between pin 11 and pin 12 closed if the turbopump is above the switchpoint
12	Contact Output 1: Switchpoint attained	
13	Contact Output 2: Collective malfunction message	contact ¹⁾ between pin 13 and pin 14 open in the event of a collective malfunction
14	Contact Output 2: Collective malfunction message	
15	Analog output	rotation speed proportional output voltage 0 - 10 VDC = 0 - 100 % * f _{end} /load R ≥ 10 kΩ

1) The following technical data is applicable for the contacts: $U_{max} = 50 \text{ VDC}$
 $I_{max} = 1 \text{ A}$

3.11. Connecting The Serial Interface RS 485

An external operating component (DCU 001/DCU 100) or an external computer can be connected via the connection "RS 485" on the TC 600 with the use of a shielded 8 pole modular connecting cable contained with the delivery.

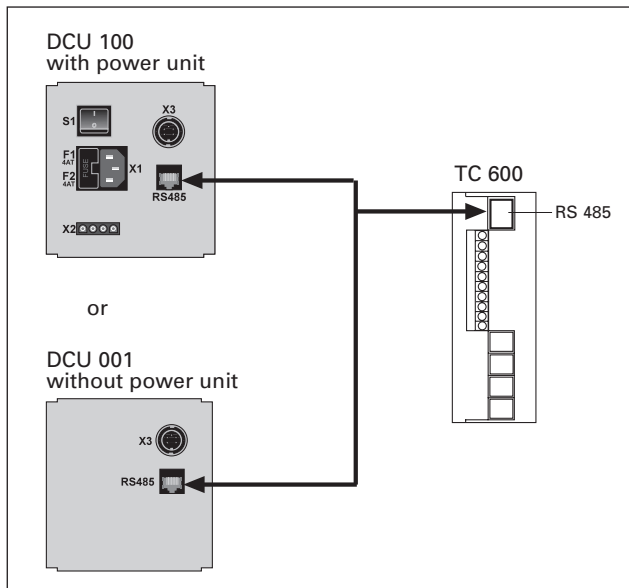

The serial interface is galvanically and safely separated from the maximum supply voltage from the TC 600.

Connection

Designation	Value
Serial interface type:	RS 485
Baud rate:	9600 Baud
Data file word length:	8 bit
Parity:	no parity
Start bits:	1
Stop bits:	1..2

The electrical connections in the TC 600 are optically decoupled.

Pin	Occupancy
1	not connected
2	+ 24 V output (loadable with ≤ 210 mA)
3	not connected
4	not connected
5	RS 485: D+ (DO / RI)
6	Gnd
7	RS 485: D- (D \bar{O} / R \bar{I})
8	not connected

RS 485



1 ... 8

(View from the plug side of the TC 600)



It is possible to connect an RS 232 (e.g. PC) via a level converter (please see "Accessories").

Connecting The RS 485

Connection to a fixed bus system

- ➔ Connect all units with D+ (pin 5 / RS 485) and D- (pin 7 / RS 485) to the bus.
- ➔ The bus must be closed at both ends.

The connections should be made in accordance with the specification of the Serial Interface RS 485.

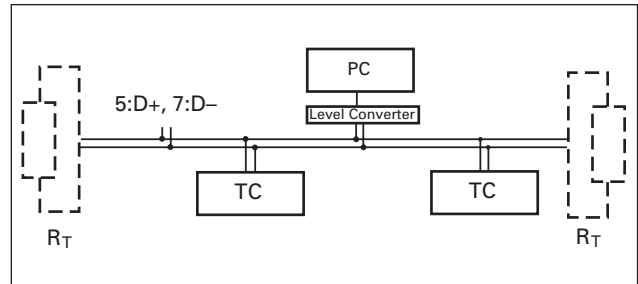

All units connected to the bus must have differing serial interface addresses (parameter 797).

The group address of the TC 600 is 960.



Only SELV may be connected to the Serial Interface RS 485.

All switched on remote functions have priority over the serial interface functions.



Please refer to Operating Instructions PM 800 488 BN for detailed operating procedures and electrical data in respect of the Serial Interface RS 485.

Profibus DP Gateway TIC 250 is available (accessory) for connecting an Electronic Drive Unit TC 600 to a Profibus DP. Please refer to the respective Operating Instructions PM 800 599 BN for detailed information on the operation of the TIC 250.

3.12. Connections Diagram

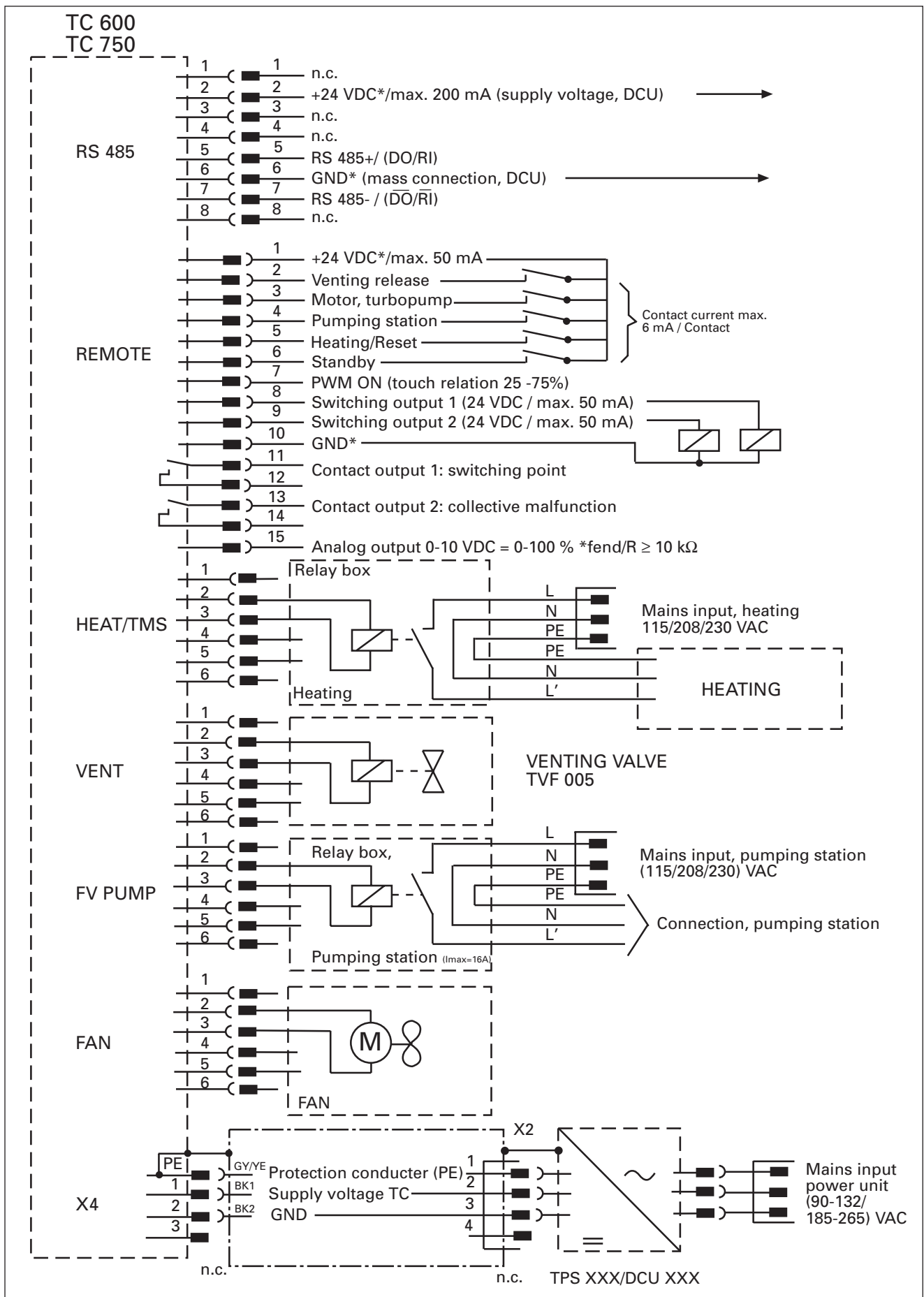

4. Operations

4.1. Before Switching On

Sections 4.1. to 4.3. refer only to operating the pump in its condition on delivery, without the DCU operating unit. The bridges "venting release", "motor, TMP ON" and "pumping station ON" are fitted in the remote control plug.



Turbopump rotors rotate at high speed. When the high vacuum flange is open there is a danger of injury and of damage to the pump caused by objects falling into the pump. Therefore never operate the pump with open high vacuum flange.

- ➔ With water cooling: Open cooling water supply and check flow.
- ➔ Plug connecting cable 8a ("Accessory") into the TC 600 and connect with Power Unit TPS 100 on X2 (please see Section 3.8.).

Please note:

The following pre-settings have been programmed:

- Running up time 8 min
- Rotation speed switchpoint 80%
- Automatic venting 50%

These settings can only be altered via Serial Interface RS 485 (DCU or PC); please refer to the respective operating instructions.

4.2. Switching ON

- ➔ Switch on the turbopump with switch S1 on the power unit.
- With air cooling the cooling fan is also switched on via Electronic Drive Unit TC 600.
- Once the self test has been successfully completed on the TC 600 (duration approximately 10 seconds), both the turbopump and the backing pump (if connected) begin operating.

Rear panel, TPS 100

- S1 ON/OFF switch
- X1 Mains connection
- X2 Connection TC 600
- F1 Fuse
- F2 Fuse

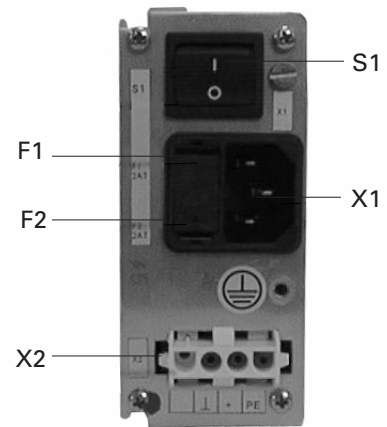

Take care when pumping hazardous gases and observe the safety precautions of the gas manufacturer.

4.3. Switching OFF And Venting

Before coming to rest after switching off, the turbopump must be vented in order to prevent contamination.

- ➔ Close the fore-vacuum.
- ➔ Switch off the turbopump with switch S1 on the power unit.
- ➔ Venting
 - There are three possibilities to vent turbopump:
 - **Manual venting**
Open the venting screw (on delivery, screwed in) on the venting connection about one turn.
 - **Venting with the Venting Valve TVF 005** (accessories)
Venting release via the remote control (please see Section 4.7.) or via the serial interface which is selectable via DCU or interface (see Operating Instructions, "Pumping Operations With The DCU", PM 800 547 BN).
 - **Venting in two stages** when the vacuum chamber should be vented as quickly as possible.
First stage: venting with a pressure increase rate of 15 mbar/s for 20 seconds.
Second stage: venting with an optionally large venting valve.

The valve cross-section for a venting rate of 15 mbar/s must be compatible with the size of the vacuum chamber. Where small vacuum chambers are involved, the PFEIFFER Venting Valve TVF 005 can be used for first stage venting.

- ➔ Shut off water supply (if installed).

4.4. Operations With The DCU 001/DCU 100

Operations with the DCU 001 or DCU 100 should be carried out in accordance with the relevant Operating Instructions PM 800 477 BN (DCU description) and PM 800 547 BN (operating the pump with the DCU).



Where operations with the DCU are involved, the remote plug 8d on the TC 600 (please refer to Section 2.1.) should be disconnected.

4.5. Gas Type Dependent Operations



Water cooling is required if the pumps are to be operated with gas load.

Where high level gas loads and rotation speeds are involved, the resulting friction subjects the rotor to the effect of great heat. To avoid over-heating, a power rotation speed characteristic line is implemented in the TC 600; this ensures that where maximum gas loads are involved, the pump will operate at any rotation speed without the danger of damage arising.

The maximum power is dependent on the type of gas. Two characteristic lines are available for any type of gas in order to fully exploit the power potential of the pump:

- "Gas-Mode 0" for gases with molecular mass ≥ 40 as, for example, Argon;
- "Gas-Mode 1" for all lighter gases.

Works setting: "Gas-Mode 0"

- ➔ Set the applicable gas mode on the TC 600 via the DCU (please refer to Operating Instructions "Pumping operations with The DCU" PM 800 547 BN).



Pumping gases with molecular mass ≥ 40 with the incorrect gas mode can cause damage to the pump.

For the vertex of the power characteristic line please refer to Section 8. Technical Data.

Maximum power is applied when the pump starts in order to limit the time required. Once the set rotation speed is attained, switching to the selected power characteristic line is automatic.

If the gas dependent maximum power is exceeded, the rotation speed is reduced until equilibrium between the permissible power and gas friction is attained. The power limitation serves to protect the pump against thermal overloading. In order to avoid rotation speed fluctuations it is recommended to set, in rotation speed setting mode, the equilibrium frequency or a somewhat lower frequency.



There can be types of pump whereby there is no differentiation between the two "gas modes" settings.

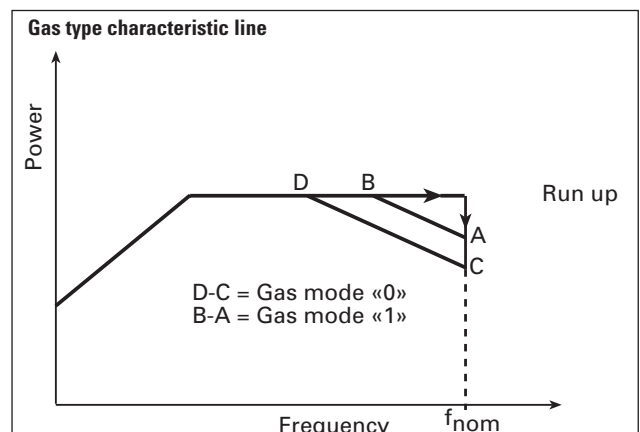

4.6. Shutting Down For Longer Periods



If aggressive or hazardous gases are pumped there is a danger of personal injury resulting from coming into contact with process gases. Before removing a turbopump from the system, first:

- Vent the turbopump with a neutral gas or dry air.
- Ensure that there is no residual process gas in the system nor in the feeder lines.

If the turbopump is to be shut down for more than a year:

- ➔ Remove turbopump from the system.
- ➔ Change the lubricant reservoir (see Section 7.1.).



Lubricant TL 011 should not be used when there have been no operations for **2 years**.

- ➔ Close the high vacuum flange and evacuate the turbopump via the fore-vacuum flange.
- ➔ Vent turbopump via the venting connection with nitrogen or dry air.
- ➔ Close fore-vacuum and venting connection by blank flanging.
- ➔ Place the pump vertically on its rubber feet.
- ➔ In rooms with moist or aggressive atmospheres, the turbopump must be air-sealed in a plastic bag together with a bag of dessicant, e.g silicagel.



If the pump has been shut down for **3 years**, the bearing must be changed (please contact PFEIFFER Service).

4.7. Operations With The Remote Control Unit

Remote control operations can be performed via the connection with the designation "REMOTE" on the TC 600.

For pin occupancy and remote plug functions please refer to the table in Section 3.10..

Inputs 2 - 6 are activated if they are connected with the 24 V on pin 1 (active high; please see Section 3.12. Connections Diagram).



On delivery there is a bridge between Pin 1, Pin 2, Pin 3 and Pin 4 on the TC 600 mating plug.

Once operating voltage has been supplied and on successful completion of the self-test on the TC 600, the turbopump and any possible connected backing pump is started.

Venting Release (Optional)

Automatic venting:

Venting frequency	Switch off the pumping station	Mains power failure ¹⁾
< 750 Hz (correspond to 50% of the final rotation speed)	venting valve opens for 150 ms at 4 s intervals	venting valve opens for 150 ms at 4 s intervals
< 500 Hz	venting valve opens for 3600 s (works setting)	venting valve opens as long as sufficient energy is generated by the turbopump

1) When mains power is restored the venting procedure is interrupted.

Venting blocked:

Venting does not take place.

Other venting modes:

Other venting modes can be selected via the DCU.

Motor, Turbopump

When the pumping station is switched on and once the self test has been successfully completed (duration approximately 10 seconds), the turbopump is set in operation.

During operations, the turbopump can be switched on and off while the pumping station is switched on.

Thereby the turbopump will not be vented.

Pumping Station

Any connected pumping station components are started up (e.g. backing pump, venting valve, air cooling) and with simultaneous activation of the input "motor, turbopump" the turbopump is set in operation once the self test has been successfully completed (duration approximately 10 seconds).

Heating/Reset

Heating (optional)

Once the rotation speed switchpoint is attained the heating unit is switched on; when the rotation speed switchpoint is fallen below the heating unit is switched off.

Reset

The heating input has two functions (please see Section 3.10., point 5 "Reset").

Standby

The pump can be operated optionally at 66% of its nominal rotation speed (standby ON) or at its nominal rotation speed (standby OFF).

Rotation Speed Setting Mode Via Input PWM

The supply of pulse width modulated signals (PWM) with a ground frequency of 100 Hz $\pm 20\%$ with an amplitude of maximum 24 V and a key ratio of 25-75% enables the rotation speed to be set in the range 20-100% of the nominal rotation speed.

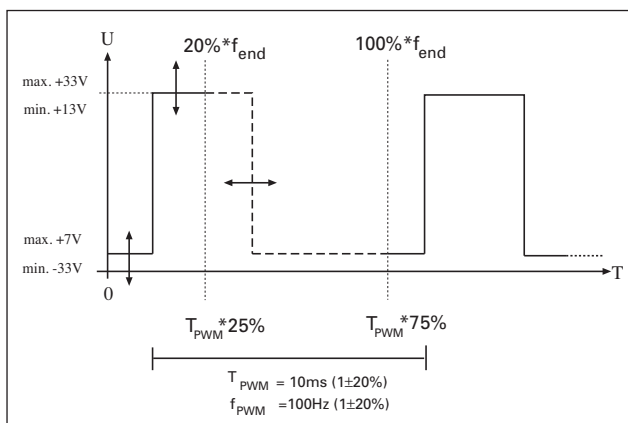

If no signal is present the pump accelerates up to its final rotation speed.

A PWM adapter box for rotation speed setting operations for the turbopump is available as an option (please see "Accessories").

Switching Outputs

Switching outputs 1 and 2 can be loaded with a maximum 24 V / 50 mA per output. The following functions are assigned to the switching outputs:

Switching output 1: Active high when the rotation speed switchpoint is attained. The switchpoint for the turbopump is set at 80% of the nominal rotation speed. It can be used, for example, for a message "pump ready to operate".

Switching output 2: Active low with a malfunction - collective malfunction message.

The connection of a relay is made between pin 10 (mass) and the respective switching output pin 8 or pin 9 (see Section 3.12. Connections Diagram).

5. Monitoring Operations

5.1. Operations Display Via LED

Certain operations modes of the turbopump and the TC 600 can be ascertained via the two integrated LEDs located on the front panel of the TC 600.

The following operations modes are displayed:

LED		Cause
I	4	
Glows green		<ul style="list-style-type: none"> – Power unit OK – Function "pumping station ON" carried out
Flashes green		<ul style="list-style-type: none"> – Power unit OK – Pumping station OFF
Blinks green		<ul style="list-style-type: none"> – Mains power supply failure
	Glows red	<ul style="list-style-type: none"> – Collective malfunction (for example, run-up time error, over-temperature, turbopump or TC 600) – Switching output 2 active (low)
	Blinks red	<ul style="list-style-type: none"> – Warning (e.g. supply voltage short circuit to earth, mains power failure)

5.2. Turbopump Temperature Management

Where impermissible motor temperatures are involved or the temperature of the casing is too high, the motor current is reduced.

This can lead to dipping below the set rotation speed switch-point and results in the turbomolecular pump being switched off.

LED on the TC 600 glows red: Collective malfunction.



Differentiated malfunction and warning signals are only possible with the use of the DCU.

6. What To Do In Case Of Breakdowns?

Problem	Possible Causes	Remedy
Pump doesn't start; None of the integrated LEDs glow on the TC 600	<ul style="list-style-type: none"> • Power supply interrupted • Incorrect operations voltage supplied • Pins 1-3 and 1-4 on the remote plug not connected • No supply of operations voltage • Defect TC 600 • Reduction in the voltage in the cable 	<ul style="list-style-type: none"> • Check fuse in the power pack unit • Check plug contacts on the mains power unit • Check power unit feeder line • Check voltage on the power unit (24 V DC) at connection X2 • Supply correct operations voltage • Connect pins 1-3 and 1-4 on the remote plug • Check plug contacts on the power unit • Inform PFEIFFER Service of need for repair • Use suitable cable
Pump doesn't attain nominal rotation speed within the set run-up time Pump cuts out during operations	<ul style="list-style-type: none"> • Fore-vacuum pressure too high • Leak or too much gas • Rotor sluggish caused by defective bearing • TC run-up time too short • Thermal overloading caused by <ul style="list-style-type: none"> – Water flow insufficient – Insufficient air supply – Fore-vacuum pressure too high – Ambient temperature too high 	<ul style="list-style-type: none"> • Check backing pump function • Check seals • Seek leak and repair • Reduce supply of process gas • Check bearing (noises?): Inform PFEIFFER Service • Set longer start-up time with the DCU or PC • Ensure free flow • Ensure adequate air supply • Reduce fore-vacuum pressure • Reduce ambient temperature
Pump doesn't attain final pressure	<ul style="list-style-type: none"> • Pump dirty • Leak in vacuum chamber, lines or pump 	<ul style="list-style-type: none"> • Bake out pump • If seriously contaminated: Request PFEIFFER Service to clean • Seek leak starting with vacuum chamber • Repair leak
Unusual operating noises	<ul style="list-style-type: none"> • Bearing damaged • Rotor damaged • Splinter shield (if fitted) not seated firmly 	<ul style="list-style-type: none"> • Inform PFEIFFER Service of need for repair • Inform PFEIFFER Service of need for repair • Check seat of splinter shield (see Section 3.2.)
Red LED on the TC 600 glows	<ul style="list-style-type: none"> • Collective malfunction 	<ul style="list-style-type: none"> • Reset via mains OFF/ON or remote pin 5 • Different malfunction display with the DCU possible ¹⁾
Red LED on the TC 600 flashes	<ul style="list-style-type: none"> • Warning through: <ul style="list-style-type: none"> – Mains power failure – Supply voltage short circuit to earth 	<ul style="list-style-type: none"> • Different warning message with the DCU possible ¹⁾ • Check power unit voltage • Check power unit mains connection • Check power unit voltage for short circuit to earth

1) Without a DCU inform PFEIFFER Service to check the cause of trouble.

7. Maintenance



No liability for personal injury nor material damage will be accepted for damages and operational interruptions which have been caused by improper maintenance; in addition, all guarantees become invalid.

- You can change the lubricant reservoir yourself (please see Section 7.1.).
- Please contact your local PFEIFFER service for all other maintenance and service work.



Apply no mechanical stress to the TC 600.

7.1. Replacing The Lubricant Reservoir

The lubricant reservoir should be replaced at least once a year.

Where extreme operating conditions or unclean processes are involved, the replacement interval should be checked with your PFEIFFER Service Center.

- ➔ Switch off the turbopump, vent to atmospheric pressure (see Section 4.3.) and allow to cool as necessary.
- ➔ If necessary, remove the turbopump from the system.
- ➔ Unscrew rubber feet 6 from the underside of the pump.
- ➔ Remove the locking cover 90 on the underside of the pump with suitable tool E (order number PV M040 550 AX or adjusting pin key); take care with the O-ring 91.
- ➔ Lever out the lubricant reservoir with the help of two screwdrivers.



Lubricant reservoir can contain toxic substances from the medium pumped. Lubricant must be disposed of in accordance with the respective regulations.

Safety instructions data sheet for the lubricant on request.

Remove locking cover and extract lubricant reservoir

- 6 Rubber feet (4x)
- 90 Locking cover
- 91 O-ring
- 92 Lubricant reservoir
- 93 O-ring
- E Tool

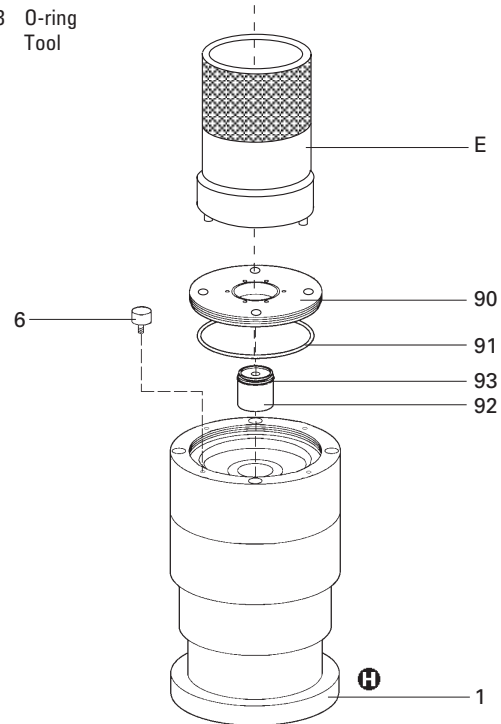

- ➔ Clean off any dirt on the pump and locking cover with a clean, fluff-free cloth.
- ➔ Insert new lubricant reservoir 92 up to the O-ring 93 in the pump.



The Lubricant reservoir 92 is already filled with Lubricant TL 011.

- ➔ Screw in locking cover 90 with O-ring 91. The lubricant reservoir is brought into the correct axial position with the locking cover.
- ➔ Screw the rubber feet 6 back in.

8. Service

Do Make Use Of Our Service Facilities

In the event that repairs are necessary a number of options are available to you to ensure any system down time is kept to a minimum:

- Have the pump repaired on the spot by our PFEIFFER Service Engineers;
- Return the pump to the manufacturer for repairs;
- Replace the pump.

Local PFEIFFER representatives can provide full details.



Please take into account that where PFEIFFER Service replacement service is involved the standard operating parameters are always preset.

If your application requires different parameters, please modify accordingly.



The turbopump and the Electronic Drive Unit TC 600 form a single unit and must therefore be returned complete for repair purposes. Before returning the unit it should be ensured that the power unit is not the cause of the malfunction (checking the power unit).

Before Returning:

- ➔ Dismantle all accessories.
- ➔ Please attach a clearly visible notice "Free of harmful substances" (both on the unit and also on the delivery note and any accompanying letters).

"Harmful substances" are substances and preparations as defined in the current, local, dangerous substances regulations; in the U.S.A. as

"materials in accordance with the Code of Federal Regulations (CFR) 49 Part 173.240 Definition and Preparation". We will carry out the decontamination and invoice this work to you if you have not attached this note. This also applies where the operator does not have the facilities to carry out the decontamination work. Units which are contaminated microbiologically, explosively or radioactively cannot be accepted as a matter of principle.

Fill Out The Declaration Of Contamination

- ➔ In every case the "Declaration of Contamination" must be completed diligently and truthfully.
- ➔ A copy of the completed declaration must accompany the unit; any additional copies must be sent to your local PFEIFFER Service Center.

Please get in touch with your local PFEIFFER representatives if there are any questions regarding contamination.



Decontaminate units before returning or possible disposal. Do not return any units which are microbiologically, explosively or radioactively contaminated.

Returning Contaminated Units

If contaminated have to be returned for maintenance/repair, the following instructions concerning shipping must be followed:

- ➔ Neutralise the pump by flushing with nitrogen or dry air.
- ➔ Seal all openings to the air.
- ➔ Seal pump or unit in suitable protective foil.
- ➔ Ship units only in appropriate transport containers.



Repair orders are carried out according to our general conditions of sale and supply.

If repairs are necessary, please send the pump together with a short damage description to your nearest PFEIFFER Service Center.

Contact Addresses And Telephone Hotline

Contact addresses and telephone numbers can be found on the back cover of these operating instructions.

9. Technical Data

Feature	Unit	TMH 071 P	TMH 071 P	TMU 071 P
Connection nominal diameter Inlet Outlet Venting connection		DN 40 ISO-KF DN 16 ISO-KF/G 1/4" G 1/8"	DN 63 ISO-K DN 16 ISO-KF/G 1/4" G 1/8"	DN 63 CF-F DN 16 ISO-KF/G 1/4" G 1/8"
Nominal rotation speed Standby rotation speed Start-up time Noise level Final pressure, backing pump	1/min 1/min min dB (A) mbar	90 000 60 000 2 < 45 < 10	90 000 60 000 2 < 45 < 10	90 000 60 000 2 < 45 < 10
Maximum permissible rotor temperature Permissible heat radiation power	°C W	90 4	90 4	90 4
Volume flow rate for Nitrogen N ₂ Helium He Hydrogen H ₂	l/s l/s l/s	33 38 39	60 55 45	60 55 45
Compression ratio for N ₂ He H ₂		> 10 ¹¹ 1 · 10 ⁷ > 10 ⁵	> 10 ¹¹ 1 · 10 ⁷ > 10 ⁵	> 10 ¹¹ 1 · 10 ⁷ > 10 ⁵
Maximum fore-vacuum pressure for N ₂ He H ₂	mbar mbar mbar	18 17 8	18 17 8	18 17 8
Maximum gas throughput ¹⁾ With water cooling N ₂ He With air cooling ²⁾ N ₂ Maximum gas throughput at intake pressure of 0.1 mbar ³⁾ With water cooling N ₂ He H ₂	mbar l/s mbar l/s mbar l/s mbar l/s mbar l/s mbar l/s mbar l/s	1.1 2.5 0.45 2.2 2.6 2	1.1 2.5 0.45 2.2 2.6 2	1.1 2.5 0.45 2.2 2.6 2
Vertex power characteristics line ⁴⁾ A B C D	W / Hz W / Hz W / Hz W / Hz	80 / 1500 80 / 1500 55 / 1500 80 / 1300	80 / 1500 80 / 1500 55 / 1500 80 / 1300	80 / 1500 80 / 1500 55 / 1500 80 / 1300
Final pressure ⁵⁾ With rotary vane pumps With diaphragm pumps	mbar mbar	< 1 · 10 ⁻¹⁰ < 1 · 10 ^{-7 6)}	< 1 · 10 ⁻¹⁰ < 1 · 10 ^{-7 6)}	< 1 · 10 ⁻¹⁰ < 1 · 10 ^{-7 6)}
Lubricant Maximum cooling water consumption with water at 15 °C ⁷⁾ Cooling water temperature Permissible ambient temperature with air cooling Heating power consumption	l/h °C °C W	TL 011 100 5 - 25 0 - 35 32	TL 011 100 5 - 25 0 - 35 32	TL 011 100 5 - 25 0 - 35 32
Weight Permissible magnetic field	kg mT	2.8 4	2.8 4	3.5 4
Operating voltage Duration ⁷⁾ - / max. current consumption Duration ⁷⁾ - / max. power Protection class ⁸⁾ Relative humidity	VDC A W % %	24 ± 5% 4.1 / 4.6 100 / 110 IP 30 5-85 non-condensing	24 ± 5% 4.1 / 4.6 100 / 110 IP 30 5-85 non-condensing	24 ± 5% 4.1 / 4.6 100 / 110 IP 30 5-85 non-condensing

- 1) Until frequency fall-off; higher gas throughputs with reduced rotation speed.
- 2) Until ambient temperature 30 °C.
- 3) Rotation speed of pump may drop below the nominal rotation speed.
- 4) For gas characteristic lines please refer to Section 4.4.

- 5) In accordance with German Industrial Standard 28428 the final pressure which is attained in a measuring dome 48 hours after baking out.
- 6) Final pressure only attainable with metallic seal on the high vacuum flange (final pressure with viton seal: < 1 · 10⁻⁷ mbar).
- 7) At maximum gas throughput.
- 8) Protection class IP 54 is afforded for the Electronic Drive Unit TC 600 by retro-fitting a cover plate (Accessory) to the TC 600.

9.1. Dimensions Diagram

TMH 071 P / TMU 071 P

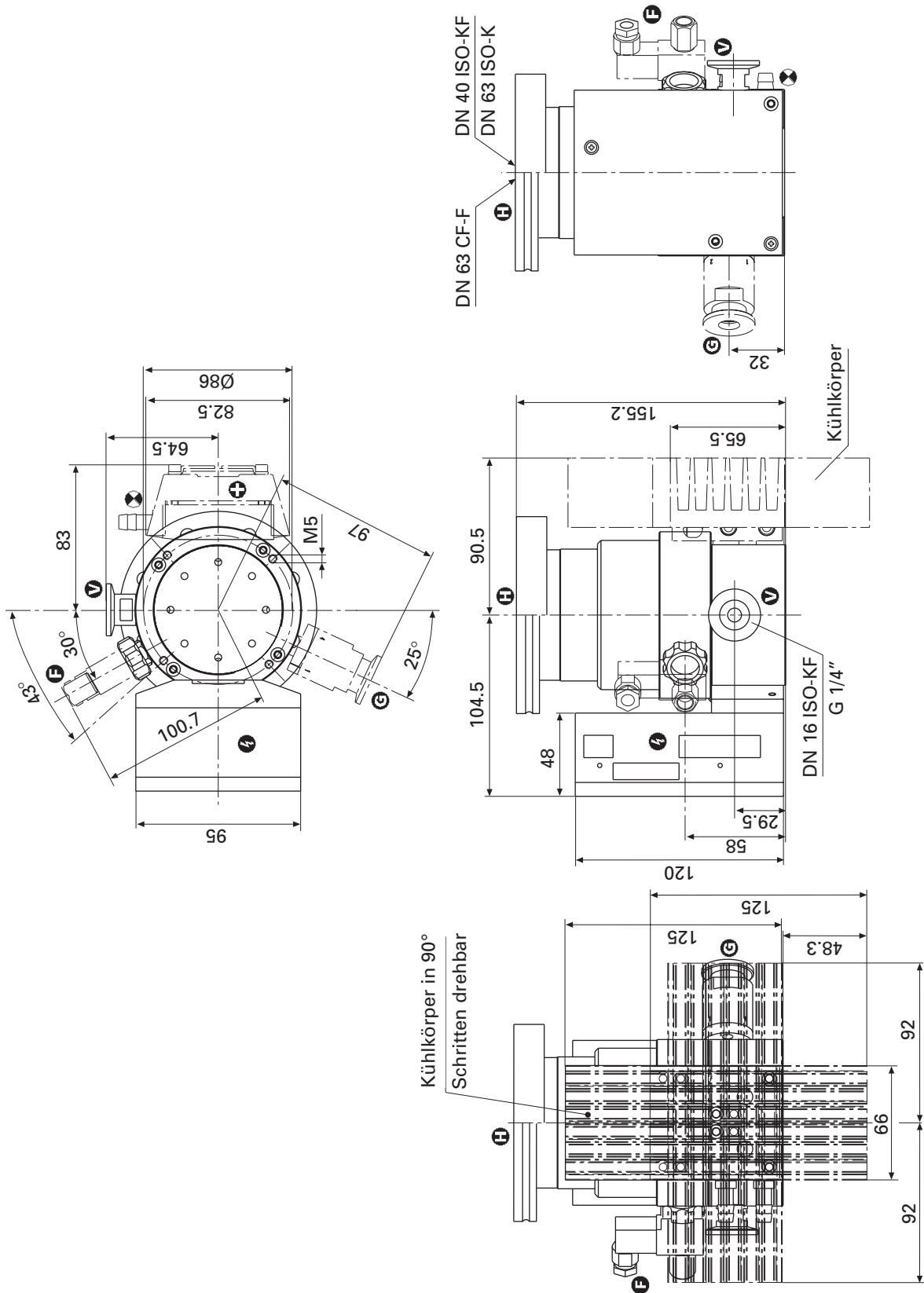

10. Spare Parts

Pos.	Description	Pieces	Size	Number	Comments	Ordering Quantity
	Spare parts TMH 071 P/TMU 071 P					
	Set of seals	1		PM 083 077 -T		
6	Rubber foot	4		P 3695 700 ZD		
17	USIT ring	1		P 3529 133 -A		
90	Locking cover	1		PM 083 021 -X		
91	O-ring	1	68 x 3	P 4070 972 PV		
92	Lubricant reservoir	1		PM 073 073 -T		

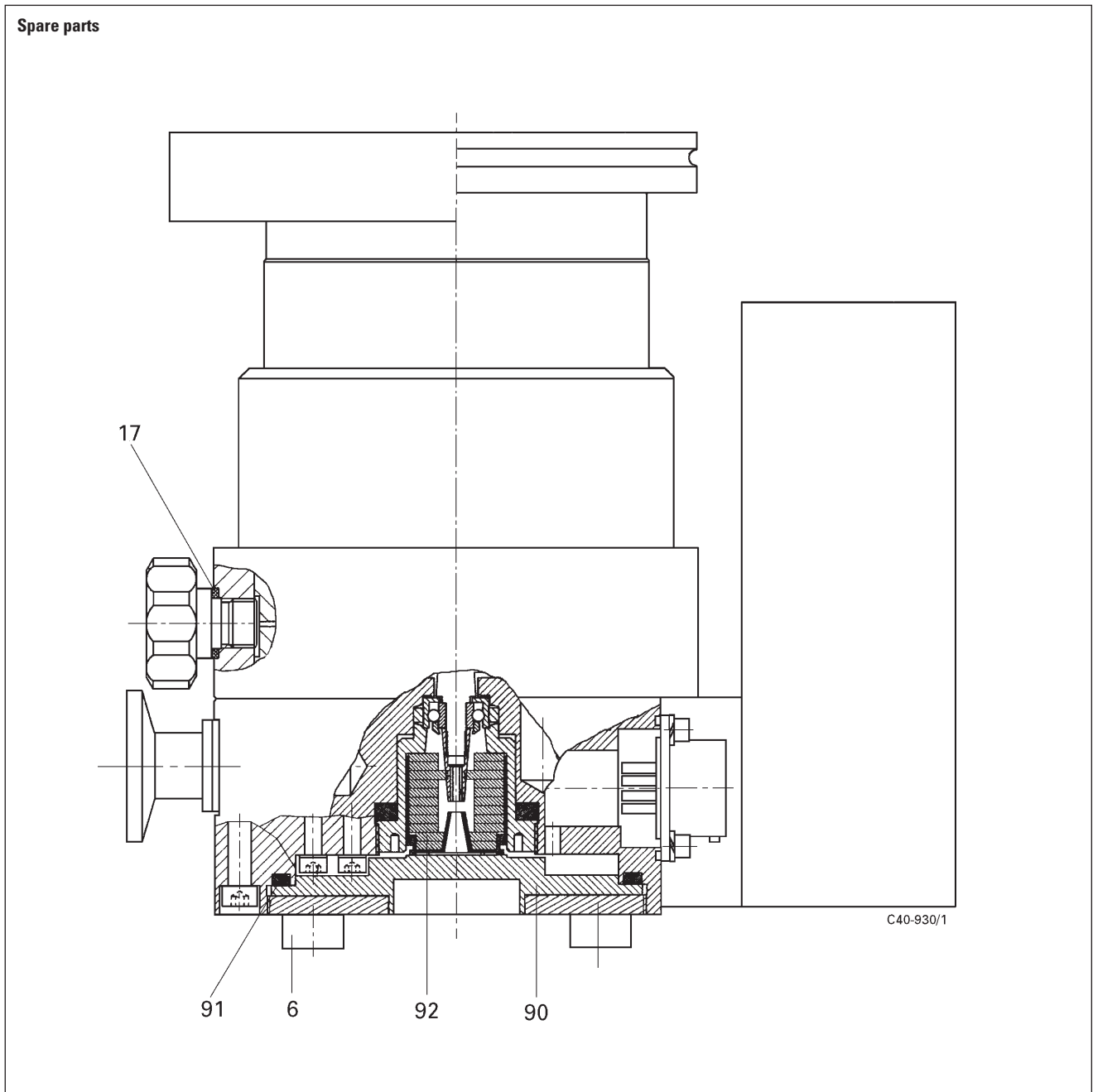

Declaration of Contamination of Vacuum Equipment and Components

The repair and/or service of vacuum components will only be carried out if a correctly completed declaration has been submitted. Non-completion will result in delay.

The manufacturer could refuse to accept any equipment without a declaration.

This declaration can only be completed and signed by authorised and qualified staff:

1. Description of component:

- Equipment type/model: _____
- Code No.: _____
- Serial No.: _____
- Invoice No.: _____
- Delivery Date: _____

2. Reason for return:

3. Equipment condition

- Has the equipment been used?
yes no
- What type of pump oil was used?

- Is the equipment free from potentially harmful substances?
yes (go to section 5)
no (go to section 4)

4. Process related contamination of equipment

- toxic yes no
- corrosive yes no
- microbiological hazard*) yes no
- explosive*) yes no
- radioactive*) yes no
- other harmful substances yes no

*) We will not accept delivery of any equipment that has been radioactively or microbiologically contaminated without written evidence of decontamination!

Please list all substances, gases and by-products which may have come into contact with the equipment:

Tradename Product name Manufacturer	Chemical name (or Symbol)	Danger class	Precautions associated with substance	Action if spillage or human contact
1.				
2.				
3.				
4.				
5.				

5. Legally Binding Declaration

I hereby declare that the information supplied on this form is complete and accurate. The despatch of equipment will be in accordance with the appropriate regulations covering Packaging, Transportation and Labelling of Dangerous Substances.

Name of Organisation: _____

Address: _____ Post code: _____

Tel.: _____

Fax: _____ Telex: _____

Name: _____

Job title: _____

Date: _____ Company stamp: _____

Legally binding signature: _____

Herstellereklärung **Manufacturer's Declaration**

im Sinne folgender EU-Richtlinien:
pursuant to the following EU directives:

- **Maschinen/Machinery 98/37/EG**
- **Elektromagnetische Verträglichkeit/Electromagnetic Compatibility 89/336/EWG**
- **Niederspannung/Low Voltage 73/23/EWG**

Hiermit erklären wir, daß das unten aufgeführte Produkt zum Einbau in eine Maschine bestimmt ist und daß deren Inbetriebnahme so lange untersagt ist, bis festgestellt wurde, daß das Endprodukt den Bestimmungen der EU-Richtlinie 98/37/EG, Anhang II B entspricht.

Wir bestätigen Konformität mit der EU-Richtlinie über elektromagnetische Verträglichkeit 89/336/EWG und der EU-Niederspannungsrichtlinie 73/23/EWG.

We hereby certify that the product specified below is intended for installation in a machine which is forbidden to be put into operation until such time as it has been determined that the end product is in accordance with the provision of EU Directive 98/37/EEC, Annex II B.

We certify conformity with EU Electromagnetic Compatibility Directive 89/336/EEC and EU Low Voltage Directive 73/23/EEC.

Produkt/Product:

TMH 071 P

TMU 071 P

Angewendete Richtlinien, harmonisierte Normen und angewendete, nationale Normen:

Guidelines, harmonised standards, national standards in which have been applied:

**EN 292-1, EN 292-2, EN 294,
EN 1012-2, EN 61010**

Unterschrift/Signature:



Pfeiffer-Vacuum GmbH
Emmeliusstrasse 33
35614 Asslar
Germany

(W. Dondorf)
Geschäftsführer
Managing Director

Herst.l./2000

Adressen • Addresses

Argentina

ARO S.A., Av. Belgrano 369,
1092 Buenos Aires, telephone +54 / 11 4331 5766,
telefax +54 / 11 4331 3572

Australia

Sciteck Australia Pty. Ltd., Suite 1B,
10-18 Cliff Street, Milsons Point, NSW 2061,
telephone +61 / 2 9954 1925, telefax +61 / 2 9954 1939

Austria

Pfeiffer Vacuum Austria GmbH
Diefenbachgasse 35, A-1150 Wien,
telephone +43 / 1 8941 704, telefax +43 / 1 8941 707
Service Hotline: +43 / 1 8941704

Branch Office, Czech Republic

Pfeiffer Vacuum Austria GmbH, Branch Prague
Zvonarska 885
CZ-156 00 Praha 5
telephone +420/2 900 42981, telefax +420/2 579 23014

Belgium / Luxemburg

Pfeiffer Vacuum Belgium N.V./S.A.
Luxemburgstraat 5, B-9140 Temse
telephone +32 / 3 710 5920, telefax +32 / 3 710 5929
Service Hotline: +32 / 3 710 5922

Brazil

Elmi Tec
Assistencia Técnica e Representação S/C Ltda.
Rua Bernadino de Campos, 551-Brooklin
CEP 04620-002 São Paulo, SP - Brasil
telephone +55 / 11 5532 0740, telefax +55 / 11 5535 3598

Chile

BERMAT S.A., Coyancura 2283, Oficina 601
Providencia, P.O. Box 9781, Santiago
telephone +56 / 2 231 8877, telefax +56 / 2 231 4294

Colombia

Arotec Colombiana S.A., Carrera 16 No. 36-89
P.O. Box 050 862, Santafe de Bogota / D.C.
telephone +57 / 1 288 7799, telefax +57 / 1 285 3604

Denmark

Pfeiffer Vacuum Scandinavia AB, Vesterengen 2,
DK-2630 Taastrup,
telephone +45 / 43 52 38 00, telefax +45 / 43 52 38 50

France

Pfeiffer Vacuum France SAS
45, rue Senouque, BP 139
F-78531 BUC Cedex
telephone +33 / (0)1 30 83 04 00,
telefax +33 / (0)1 30 83 04 04

Germany

Pfeiffer Vacuum GmbH,
Berliner Strasse 43, D-35614 Asslar
telephone +49 / 6441 802 400, telefax +49 / 6441 802 399
Service Hotline: +49 / 6441 802 333

Great Britain

Pfeiffer Vacuum Ltd.
2-4 Cromwell Business Centre
Howard Way, Interchange Park
Newport Pagnell, MK16 9QS, United Kingdom
telephone +44 / 1 908 500615, telefax +44 / 1 908 500616

Greece

Analytical Instruments S.A., 1 Mantzarou St.,
GR-15451 Athens,
telephone +30 / 10 674 8973-7, telefax +30 / 10 674 8978

Hong Kong

Pfeiffer Vacuum Asia Ltd.
Units 06-07, 17/F, Workingfield Commercial Building,
408-412 Jaffe Road, Hong Kong
telephone +852 2575 6688, telefax +852 2575 6993

India

Pfeiffer Vacuum India Ltd.
25-E Nicholson Road, Tarbund
Secunderabad 500 009,
telephone +91 / 40 775 0014, telefax +91 / 40 775 7774

Israel

ODEM Scientific Applications Ltd.
9 Hamazmera St., P.O.B. 2001 Nes Ziona
telephone +972 8 938 0333, telefax +972 8 938 0334

Italy

Pfeiffer Vacuum Italia S.p.a.
Via San Martino, 44 I-20017 RHO (Milano)
telephone +39 / 2 93 99 051, telefax +39 / 2 93 99 05 33

Japan

Hakuto Co. Ltd., C.P.O. Box 25,
Vacuum Scientific Instruments Division
C.P.O. Box 25, Tokyo 100-91
telephone +81 / 3 32 258 910, telefax +81 / 3 32 259 011

Korea

Pfeiffer Vacuum Korea Ltd.,
703 Ho, 853-1, Hankuk Mulru, Dongchonri, Suzi-Eup,
449-843 Yong-in City, Kyungkido
telephone +82 / 31 266 0741, telefax +82 / 31 266 0747

Netherlands

Pfeiffer Vacuum Nederland BV
Veldzigt 30a, NL-3454 PV De Meern,
telephone +31 / 30 6666050, telefax +31 / 30 6662794

Peru

Ing. E. Brammertz s.r.l., José Pardo 182,
Apartado 173, PE-18 Miraflores,
telephone +51 / 1 445 8178, telefax +51 / 1 445-1931

Poland

Softrade Sp.z.o.o, ul. Grunwaldzka 391,
PL-60-173 Poznan, telephone +48 / 61 8677 168,
telefax +48 / 61 8677 111

Portugal

Unilaser Lda, Taguspark
Núcleo Central, sala n° 268, Estrada Cacém-
Porto Salvo, P-2780 Oeiras
telephone +351 / 1 421 7733, telefax +351 / 1 421 7744

Singapore

APP Systems Services Pte. Ltd, 2 Corporation Road
06-14 Corporation Place, Singapore 618494,
telephone +65 / 268 2024, telefax +65 / 268 6621

Spain

Tecnovac
Tecnologia de Vacío S.L.,
Sector Literatos, 38 - Local 1
ES-28760 Tres Cantos (Madrid)
telephone +34 / 91 804 11 34, telefax +34 / 91 804 30 91

Sweden

Pfeiffer Vacuum Scandinavia AB
Johanneslundsvägen 3
SE-194 61 Upplands Väsby
telephone +46 / 8 590 748 10, telefax +46 / 8 590 748 88

Switzerland

Pfeiffer Vacuum Schweiz S.A.
Förribuckstraße 30, CH-8005 Zürich
telephone +41 / 1 444 2255, telefax +41 / 1 444 2266

South Africa

Labotec Pty Ltd., P.O. Box 6553,
Halfway House
1685 Midrand
telephone +27 / 11 315 5434, telefax +27 / 11 315 5882

Taiwan

HAKUTO Taiwan Ltd. Hsinchu office No. 103,
Hsien Chen 11th Street, Chupei,
HsinChu County, Taiwan, R.O.C.
(zip/postal code: 302)
telephone +886 / 3 554 1020, telefax +886 / 3 554 0867

Thailand

Hakuto (Thailand) Ltd.
18th Floor, Chokchai Int'l Bldg.
690 Sukhumvit Road
Klongton, Klongtoey
Bangkok 10110
telephone +662 / 259 6244, telefax +662 / 259 6243

U.S.A.

Pfeiffer Vacuum, Inc.
24 Trafalgar Square
Nashua, NH 03063-1988
USA
telephone +1 / 603 578 6500, telefax +1 / 603 578 6550

Venezuela

Secotec S.A., Apartado 3452, Caracas 1010-A,
telephone +58 / 212 573 8687, telefax +58 / 212 573 1932

Other countries

AVI - Applied Vacuum Industries GmbH
Leginglenstrasse 17A; CH-7320 Sargans
Switzerland
telephone +41 / 81 710 03 80
telefax +41 / 81 710 03 81

Scope of represented countries

Armenia, Azerbaijan, Bangladesh, Belarus, Bulgaria,
Cambodia, Estonia, Georgia, Kazakhstan, Kingdom of Nepal,
Kirghizia, Latvia, Lithuania, Maldavia, Philippines, P.R. China,
Rumania, Russia, Tajikistan, Turkmenistan, Ukraine,
Uzbekistan, Vietnam

A.E.M.S.

Advanced Equipment Materials and Systems
P.O. Box 25
Föhrenweg 18
FL-9496 Balzers
telephone +423 / 380 0550
telefax +423 / 380 0551

Scope of represented countries

Bahrain, Egypt, Iraq, Iran, Jordan, Kuwait, Lebanon, Lybia,
Oman, Pakistan, Saudi-Arabia, Sudan, Syria, Turkey, United
Arab Emirates, Yemen

Zentrale/Headquarters

Pfeiffer Vacuum GmbH

Berliner Str. 43
D-35614 Asslar

Telefon 06441/802-0
Telefax 06441/802-202
Hotline 06441/802-333
www.pfeiffer-vacuum.de

PFEIFFER  **VACUUM**