

vacuubrand

Technology for Vacuum Systems
Instructions for use



BVC control
BVC control G
BVC professional
BVC professional G

Dear customer,

Your VACUUBRAND diaphragm pumps are designed to provide you with many years of trouble-free service with optimal performance. Our many years of practical experience allow us to provide a wealth of application and safety information. Please read these instructions for use before the initial operation of your pump.

VACUUBRAND diaphragm pumps combine our many years of experience in design, construction and practical operation, with the latest developments in material and manufacturing technology.

Our quality maxim is the "zero defect" principle:

Every diaphragm pump, before leaving our factory, is tested intensively, including an endurance run of 14 hours. Any faults, even those which occur rarely, are identified and can be eliminated immediately.

After completion of the endurance run, every pump is tested, and must achieve specifications before shipment.

We are committed to providing our customers only pumps that meet this high quality standard.

While our pumps cannot eliminate all of your work, we design, manufacture and test them to ensure that they will be an effective and trouble-free tool to assist you in that work.

Yours,

VACUUBRAND GMBH + CO KG

After sales service:

Contact your local dealer or call +49 9342 808-5500.

Trademark index:

VACUU·LAN® (US-Reg.No 3,704,401), VACUU·BUS®, VACUU·CONTROL®, Peltronic®, VARIO® (US-Reg.No 3,833,788), VACUUBRAND® (US-Reg.No 3,733,388), WH₂O REALLY CARES® (US-Reg.No 4,104,537), CO₂MMITTED TO CHANGE® (US-Reg.No 4,104,536), VACUU·VIEW®, GREEN VAC® (US-Reg. No. 4,924,553) and also the shown company logos are registered trademarks of VACUUBRAND GMBH + CO KG in Germany and/or other countries.

Sekusept® is a trademark of Ecolab GmbH & Co OHG, Germany.

Pursept® and Mucosol® are trademarks of Schülke & Mayr GmbH, Germany.

neodisher® is a trademark of Chemische Fabrik Dr. Weigert GmbH & Co. KG, Germany.

Contents

Safety information!	5
Important information!	5
General information.....	7
Intended use.....	7
Setting up and installing the system.....	8
Ambient conditions	9
Operating conditions	10
Safety during operation	11
Maintenance and repair.....	14
Technical data	16
Wetted parts	18
System parts	19
On/off switch.....	21
Use and operation	22
First steps: Installation.....	22
Operation BVC control / BVC control G	24
Operation BVC professional / BVC professional G	25
Notes regarding the setting of the suction power	26
Level sensor of BVC professional / BVC professional G.....	27
During operation.....	29
Filtration.....	30
Filter and collection bottle.....	32
Disinfection routine	34
Cleaning and decontaminating	36
Autoclaving	36
Disinfection.....	37
Cleaning	39
Adjustment of the BVC level sensor to work properly with a new bottle, or to correct false alarms	40
Preparation.....	41
Adjustment routine for BVC professional with 4l polypropylene bottle	42
Adjustment routine for BVC professional with 2l glass bottle	44
Assembling of components	46
Replacing the filter.....	46
Assembling a second VHC ^{pro} connection set	47
Assembling quick coupling bottle - pump unit	49

Assembling a hose nozzle at the bottle head of the BVC	50
Quick coupling sets	51
Accessories - spare parts	52
Troubleshooting	55
Replacing diaphragms and valves.....	57
Cleaning and inspecting the pump heads	59
Replacing the diaphragm	61
Assembling the pump head	63
Replacing the fuse.....	66
Repair - Maintenance - Return - Calibration.....	67
Health and safety clearance form	69
EC Declaration of Conformity of the Machinery	70
China RoHS.....	71

Safety information!

Important information!

WARNING

- ☞ **Keep this manual complete and accessible to personnel at all times!**
- ☞ **Read this manual carefully before installing or operating the equipment. Observe the instructions contained in this manual.**

- ☞ **Do not modify the equipment without authorization.**

NOTICE

This manual is an integral part of the equipment described therein. It describes the safe and proper use of the vacuum pump.

Make operating personnel aware of dangers arising from the pump and the pumped substances.

VACUUBRAND disclaims any liability for inappropriate use of these pumps and for damage from failure to follow instructions contained in this manual.

This manual is only to be used and distributed in its complete and original form. It is strictly the users' responsibility to check carefully the applicability of the guidance in this manual with respect to his product.

Manual-no.: 999263 / 07/07/2017

The following signal word panels and safety symbols are used throughout this manual:



This is the safety alert symbol. It is used to alert you to potential personal injury hazards. Obey all safety messages that follow this symbol to avoid possible injury and death.



➔ DANGER indicates a hazardous situation which, if not avoided, will result in death or serious injury.



☞ WARNING indicates a hazardous situation which, if not avoided, could result in death or serious injury.



• CAUTION indicates a hazardous situation which, if not avoided, could result in minor or moderate injury.



NOTICE is used to address practices not related to personal injury.



Caution! Hot surface!



Disconnect equipment from AC power.



Formatting used in this manual:

Note: The signal word panels in all sections of this manual always refer to all paragraphs of the same format (➔ / ☞ / • / plain text) following each signal word panel.

The document "Safety information for vacuum equipment" is part of this manual! Read the "Safety information for vacuum equipment" and observe the instructions contained therein!

General information

WARNING

- ☞ Read and comply with this manual before installing or operating the equipment.
- ☞ Before operating the equipment read and comply with the section "Cleaning and decontamination"!

NOTICE

Remove all packing material, remove the product from its packing-box, remove the protective covers from the inlet and outlet ports and keep, inspect the equipment.

If the equipment is damaged, notify the supplier and the carrier in writing within three days; state the item number of the product together with the order number and the supplier's invoice number. Retain all packing material for inspection.

Do not use the equipment if it is damaged.

Lift and transport the equipment at the provided handle.

Intended use

WARNING

- ☞ Prevent any part of the human body from coming in contact with the vacuum.
- ☞ Make sure that the individual components are only connected, combined and operated according to their design and as indicated in the instructions for use. Use only original VACUUBRAND accessories.
- ☞ Comply with notes on correct vacuum and electrical connections, see section "Use and operation".

CAUTION

- The systems are designed for **ambient temperatures** during operation between +10°C and +40°C. Check the maximum temperatures if installing the system in a cabinet or a housing and make sure ventilation is adequate. Install an external automatic ventilation system if necessary.

NOTICE

Ensure that the equipment and all components are suitable for the intended application. Use the system only for **aspiration of liquids and filtration**.

Setting up and installing the system**DANGER**

➔ Equipment must be connected only to a **suitable electrical supply** and a suitable ground point. Failure to connect the motor to ground may result in deadly electrical shock.

The supply cable may be fitted with a molded European IEC plug or a plug suitable for your local electrical supply. If the plug has been removed or has to be removed, the cable will contain wires color coded as follows: green or green and yellow: earth; blue or white: neutral; brown or black: live. The device has an internal fuse.

WARNING

☞ Do not permit any **uncontrolled pressurizing** (e.g., make sure that an exhaust tubing cannot become blocked).
Risk of bursting!

☞ Due to the high compression ratio of the pumps, pressure at the outlet port may be generated that is higher than the maximum permissible pressure compatible with the mechanical stability of the system.

☞ Always provide a free and pressureless exhaust line.

CAUTION

- Comply with **maximum permissible pressures** and pressure differences; see section "Technical data". Do not operate the pumping unit with overpressure at the inlet or outlet.

- Check that line voltage and current conform with the equipment. (See rating plate.)

- Avoid overpressure of more than 0.2 bar in instances in which inert gas is connected.

NOTICE

Provide a firm level platform for the equipment. Ensure a stable position of the pump without any mechanical contact except of the pump feet. Comply with all applicable **safety regulations**.

Check fan regularly for dust/dirt, clean if necessary to avoid reduced ventilation. Avoid high heat supply. If the equipment is brought from cold environment into a room for operation, allow the equipment to warm up. (Watch for water condensation on cold surfaces.)

The diameter of the an outlet tubing should be at the least as large as the diameter of the pump connections.

Comply with all **applicable and relevant safety requirements** (regulations and guidelines), **implement the required actions and adopt suitable safety measures**.

Ambient conditions

NOTICE

To the best of our knowledge the equipment is in compliance with the requirements of the applicable EC-directives and harmonized standards (see "Declaration of conformity") with regard to design, type and model, especially directive DIN EN 61010-1. This directive gives, in detail, conditions, under which the equipment can be operated safely (see also IP degree of protection).

Adopt suitable measures in case of differences, e. g. using the equipment outdoors, installation in higher altitudes, conductive pollution or bedewing.

Pay attention to the **permissible maximum ambient temperatures** (see "Technical data").

Operating conditions

DANGER

- ➔ The devices have no approval for operation in or for pumping of potentially explosive atmospheres.
- ➔ The devices are **not suitable** to pump:
 - **unstable substances** and substances which react explosively under **impact** (mechanical stress) and/or when being exposed to **elevated temperatures** without air,
 - **self inflammable** substances,
 - substances which are **inflammable without air** and
 - **explosive substance**
- ➔ The pumps have **no approval** for operation below ground.

WARNING

- ☞ The pumps are **not suitable** for pumping dust.

CAUTION

- The devices are **not suitable** for pumping substances which may form **deposits** inside the pump. Deposits and condensate in the pump may lead to increased temperatures even to the point of exceeding the maximum permitted temperatures! Increased temperatures may cause ignition of inflammable substances that may have been deposited inside the pump during use.
- If there is a danger of the formation of **deposits** in the pump chamber (check inlet and outlet of the pump), inspect the pump chamber regularly and clean if necessary.
- **Take into consideration interactions and chemical reactions of the pumped media.**
- Ensure that the materials of the wetted parts are compatible with the pumped substances, see section "Technical data".

NOTICE

If pumping **different substances**, it is recommended that the pump be purged with air or inert gas prior to changing the pumped media in order to pump out residues and to avoid reactions of the pumped substances with each other and with the pump materials.

Safety during operation



- ➔ Avoid interactions of media in the collection bottle. Comply with material safety data sheets and notes on safe use of the manufacturer.
Do not mix incompatible disinfectants and/or incompatible reagents / solvents or any unknown substances.

For example sodium hypochlorite (chlorine bleach)

Incompatible chemicals and agents	Possible results of mixing with sodium hypochlorite (chlorine bleach)
Acids or acidic compounds (e. g. hydrochloric acid, aluminium chloride)	Release of chlorine gas
Ammonia containing compounds (e. g. ammonium hydroxide, quaternary ammonium salts)	Formation of explosive compounds, release of chlorine gas and other hazardous gases
Organic chemicals (e. g. solvents, polymers, amines, oils)	Formation of chlorinated organics, release of chlorine gas and other hazardous gases
Metals (e. g. copper, iron) Hydrogen peroxide	Release of oxygen, overpressure, rupture of a closed system
Reducing agents (e. g. sodium thiosulfate)	Production of heat, boiling
Guanidine salts (e. g. guanidine hydrochloride, guanidine thiocyanate)	Release of toxic gases, e. g. chlorine, chloramine, hydrogen cyanide



- ➔ Avoid the formation of dangerous reactions / gases in the BVC, especially in the collection bottle. If this is impossible dispose of dangerous gases at the outlet of the pump appropriately.

 **DANGER**

- ➔ Adopt suitable measures to prevent the release of dangerous, toxic, explosive, corrosive, noxious or polluting fluids, vapors and gases. In such cases, install an appropriate collecting and disposal system and take protective action for pump and environment.
- ➔ If the equipment is used in combination with **hazardous materials** (e. g., in **medical-microbiological laboratories**) check all relevant safety and health requirements and determine the applicability of regulatory limitations prior to use if necessary.
- ➔ Use appropriate safety work materials and methods if necessary, e. g., steam sterilization, sterilization indicators or germicides. For notes concerning the sterilization of wetted parts, see the “Technical Data” section and “Cleaning and decontaminating”. It is the user’s responsibility to ensure effective sterilization.
- ➔ Never operate a defective or damaged device.
- ➔ The user must take suitable precautions to prevent any formation of explosive mixtures in the expansion chamber or in the housing. In case of a diaphragm crack, for example, mechanically generated sparks, hot surfaces or static electricity may ignite these mixtures. Use inert gas for venting if necessary.
- ➔ Potentially explosive mixtures at the outlet of the pump have to be drained appropriately, evacuated, or diluted with inert gas to non-explosive mixtures.

 **WARNING**

- ☞ Check the collection bottle regularly for cracks. Never use a collection bottle with cracks nor expose it to vacuum.
- ☞ Use the system only in combination with the integrated hydrophobic filter (sterilizable) to protect pump and environment (people).

WARNING

- ☞ Comply with applicable regulations when disposing of chemicals. Take into consideration that chemicals may be polluted. Take adequate precautions to protect people from the effects of dangerous substances (chemicals, thermal decomposition products of fluoroelastomers), wear appropriate safety-clothing and safety glasses.
- ☞ Use only **OEM spare parts and accessories**; otherwise safety and performance of the equipment as well as the electromagnetic compatibility of the equipment might be reduced.
The CE mark or the cTUVus mark (see rating plate) may become void if original equipment manufacturer parts are not used.
- ☞ In case of leaks in the manifold, aspirated substances might be released into the environment. Comply especially with notes on operation and use and maintenance.
- ☞ Due to the residual **leak rate of the equipment**, there may be an exchange of gas, albeit extremely slight, between the environment and the vacuum system. Adopt suitable measures to prevent contamination of the pumped substances or the environment.

NOTICE

Maximum liquid level in collection bottle: approx. 80 %, depending on the application. (When working with low-boiling liquids, or liquids that tend to foam, the maximum liquid level might be reduced).

Ensure that, in case of failure, the system will always return to a safe status. Provide appropriate protective measures (i.e., precautions which allow for the requirements of the respective application) even for the case of failure and **malfunction**. When operating the pump, the loss of pumping or venting must not lead to a critically dangerous situation under any circumstances.

NOTICE

Electronic equipment is never 100% fail-safe. This may lead to an indefinite status of the equipment. Failure of the pumping unit (e. g., by power failure) or connected components, or change of parameters must not lead to a critically dangerous situation under any circumstances. In case of diaphragm cracks or leaks in the manifold, pumped substances might be released into the environment or into the pump housing. Comply especially with notes on operation and use and maintenance.



- Pay attention to the safety symbol "hot surfaces" on the equipment. Hot parts may cause burns if touched. Adopt suitable measures to prevent any danger arising from hot surfaces or electric sparks. Ensure that hot surfaces of the pump do not cause burns. Provide a suitable contact guard if necessary.

In case of overload, the motor is shut down by a **self-hold thermal cutout** in the winding. Attention: Manual reset is necessary. Switch off the pump or isolate the equipment from power supply. Identify and eliminate the cause of failure. Wait approx. five minutes before restarting the pump.

CAUTION

- **Attention:** In case of **supply voltage below 100V** (100-120V version), the lock of the cutout might be restricted and the pump might restart on its own after sufficient cooling down. Take suitable precautions if an automatic restart of the pump may lead to a critical dangerous situation.

Maintenance and repair

NOTICE

Wear parts have to be replaced regularly. Under typical operating conditions, the projected lifetime of the diaphragms and valves is > 15000 operating hours. Bearings have a typical durability of 40000 h. Motor capacitors have a typical durability in the range of 10000 to 40000 h depending strongly on the operating conditions like ambient temperature, humidity or load.

! DANGER

- ➔ Never operate the pump if covers or other parts of the pump are disassembled. Ensure that the pump cannot be operated accidentally.
- ➔ **Isolate equipment from power supply before removing the cover!**
- ➔ Before starting maintenance, unplug the equipment and wait 5 seconds to allow the capacitors to discharge.
- ➔ Attention: The pump might be contaminated with noxious or otherwise dangerous process chemicals that have been pumped during operation. Ensure that the pump is decontaminated before maintenance.

! WARNING

- ☞ Take adequate precautions to protect people from the effects of dangerous substances if contamination has occurred. Wear appropriate safety-clothing when you come in contact with contaminated components.
- ☞ **Wear parts have to be replaced regularly.**
- ☞ Never operate a defective or damaged pump.
- ☞ Check every motor capacitor regularly by measuring its capacity and estimating its operation time. Exchange old capacitors early enough to prevent a failure. When motor capacitors fail, they can get hot enough to melt or cause a flame which could be **dangerous for persons and equipment in the vicinity**. Motor capacitors have to be replaced by an electrician.
- ☞ Before starting maintenance, vent the system and allow sufficient cooling of the pump. Drain condensate, if applicable. Avoid the release of pollutants.

NOTICE

Ensure that **maintenance** is carried out only by suitably trained and supervised technicians. Ensure that the maintenance technician is familiar with the safety procedures which relate to the products processed by the pumping system. In order to comply with law (occupational, health and safety regulations, safety at work law and regulations for environmental protection) vacuum pumps, components and measuring instruments returned to the manufacturer can be repaired only when certain procedures (see section "**Repair - Maintenance - Return - Calibration**") are followed.

Technical data

Type		BVC control / G BVC professional / G
		Pump
Maximum pumping speed (ISO 21360) at 50/60 Hz	cfm (m ³ /h)	0.4/ 0.5 (0.7 / 0.85)
Ultimate vacuum (absolute)	Torr (mbar)	112 (150)
Maximum permissible inlet pressure (absolute)	psi (bar)	16 (1.1)
Maximum permissible outlet pressure (absolute)	psi (bar)	16 (1.1)
Rated power	hp (kW)	0.054 (0.04)
No-load speed 50/60 Hz	rpm	1500 / 1800
Control range	Torr (mbar)	112 - 637 (150 - 850)
Permissible ambient temperature storage / operation	°F (°C)	14 to 140 / 50 to 104 (-10 to +60 / +10 to +40)
Maximum installation altitude	m	2000 above mean sea level
Permissible relative atmospheric moisture during operation (no condensation)	%	30 to 85
Maximum permissible range of supply voltage: Attention: Observe speci- fications of rating plate!		100-120 V~ ±10% 50/60 Hz 230 V~ ±10% 50/60 Hz
Rated current at: 100-120 V~ 50/60 Hz 230 V~ 50/60 Hz	A A	1.9 / 1.4 0.7 / 0.5
Fuse		2 x 2.5 AT, 0.19 x 0.78 in (5 x 20 mm)
Motor protection		thermal cutout
Degree of protection IEC 529		IP 40
A-weighted emission sound pressure level* (uncertainty K _{pA} : 3 dB(A))	dB(A)	45

* Measurement according to EN ISO 2151:2004 and EN ISO 3744:1995 at 230V/50Hz and ultimate vacuum with exhaust tube at outlet.

Type		BVC control / G BVC professional / G
		System
Volume of collection bottle	gal (l)	1 (polypropylene) / 0.5 (borosilicate glass) (4 (polypropylene) / 2 (borosilicate glass))
Connection at the inlet		hose nozzle DN 3/5mm
Connection at the outlet		hose nozzle DN 8 mm / silencer
Hydrophobic filter Type Manufacturer Nominal pore diameter		Midisart® 2000 Sartorius stedim 0.2 µm
Dimensions L x W x H approx.		
BVC control	in	16.1 x 7.6 x 19.7
BVC control G	in	16.1 x 7.6 x 16.9
BVC professional	in	16.1 x 7.6 x 19.7
BVC professional G	in	16.1 x 7.6 x 16.9
BVC control	(mm)	(408 x 194 x 500)
BVC control G	(mm)	(408 x 194 x 430)
BVC professional	(mm)	(408 x 194 x 500)
BVC professional G	(mm)	(408 x 194 x 430)
Weight approx.		
BVC control / professional	lbs.	16.1 (230V) / 17.0 (120V)
BVC control G / professional G	lbs.	17.0 (230V) / 17.9 (120V)
BVC control / professional	(kg)	(7.3 (230V) / 7.7 (120V))
BVC control G / professional G	(kg)	(7.7 (230V) / 8.1 (120V))

Wetted parts

Components	Wetted materials
Pump	
Housing cover insert	PTFE, carbon reinforced
Head cover	ETFE, carbon fibre reinforced
Diaphragm clamping disc	ETFE, carbon fibre reinforced
Diaphragm	PTFE
Valve	PTFE / FFKM
Inlet	ETFE
Outlet	ETFE
Silencer	silicone rubber
Filter	
Diaphragm	PTFE
Housing	PP
Tubing	silicone rubber
Collection bottle 4l	
Bottle / screw cap	PP
Hose nozzle at bottle head (connection VHC ^{pro})	PP
Hose in bottle	PTFE
Hose nozzle (connection filter)	PPS, glass fibre reinforced
Counter nut	PP
Closing screw	PPS, glass fibre reinforced
Collection bottle 2l	
Bottle	Borosilicate glass
Cap insert	PP
Flat seal	EPDM
Hose nozzle at bottle head (connection VHC ^{pro})	PP
Hose in bottle	PTFE
Hose nozzle (connection filter)	PPS, glass fibre reinforced
Closing screw	PPS, glass fibre reinforced

System parts

Position	Designation
1	Pump ME 1C
2	Mains connection
3	Fuse holder
4	On / Off switch
5	Touch panel
6	Rating plate
7	Outlet
8	Connection tubing
9	Hydrophobic protection filter
10	Connection filter
11	Connection VacuuHandControl VHC ^{pro}
12	Closing screw (optional: connection second VHC ^{pro})
13	Screw cap / bottle cap with insert
14	Collection bottle
15	Handle
16	Level sensor

BVC control

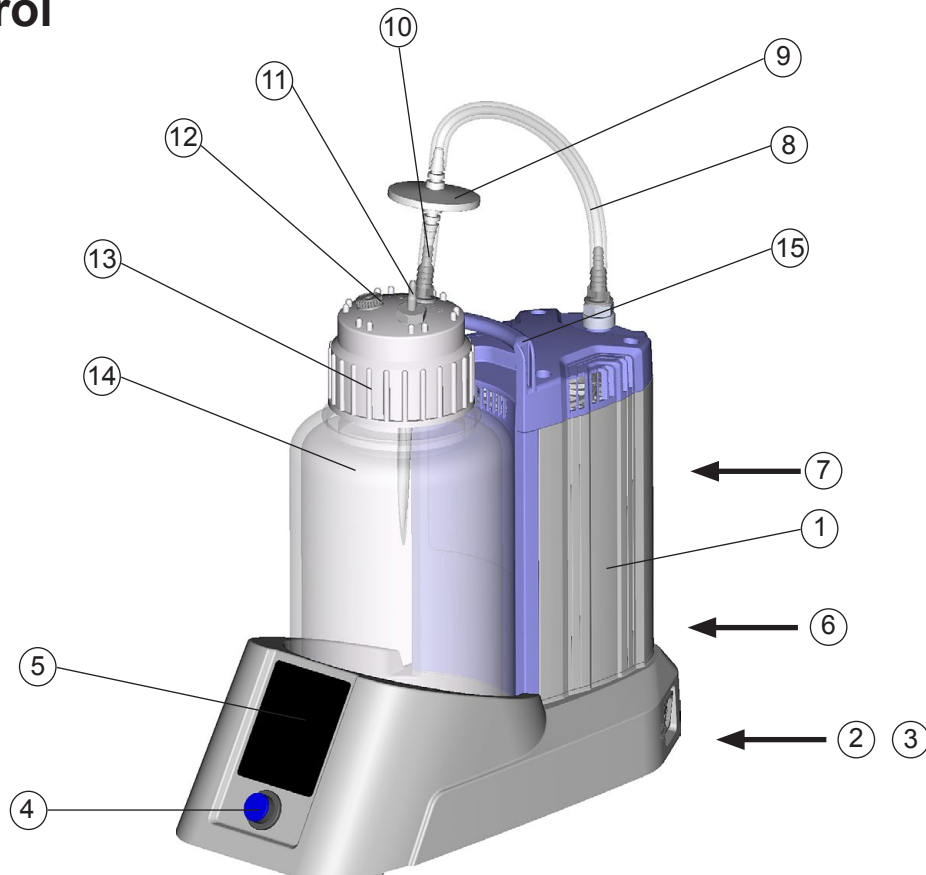

BVC control G

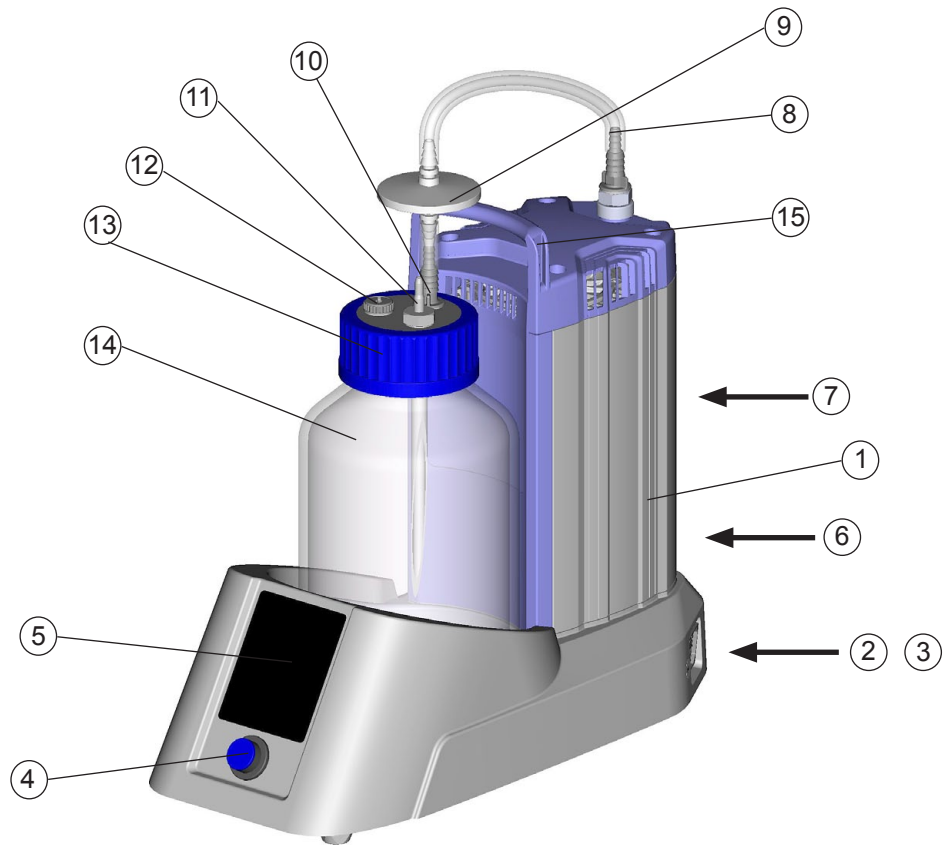

BVC professional

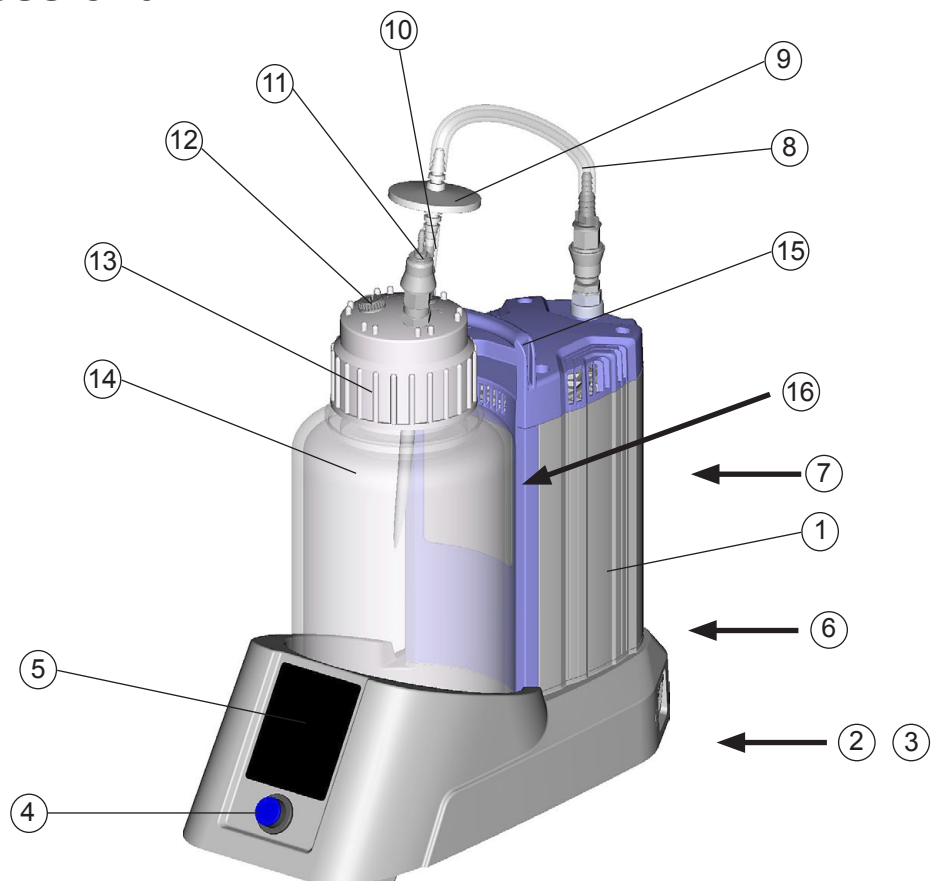

BVC professional G

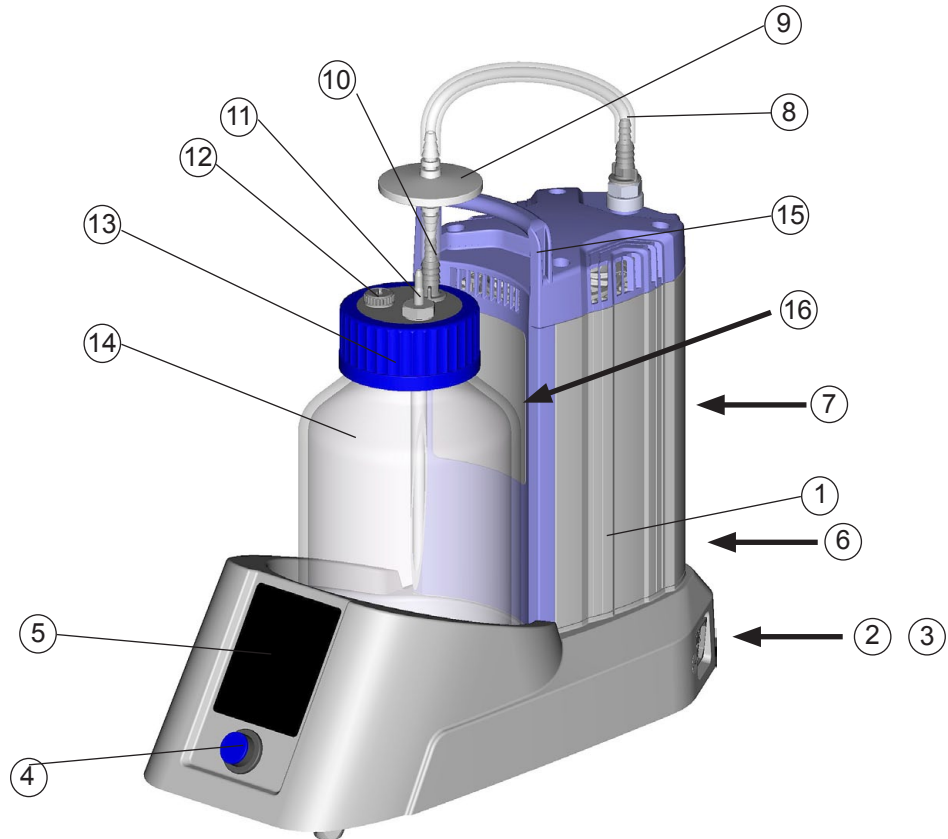

On/off switch

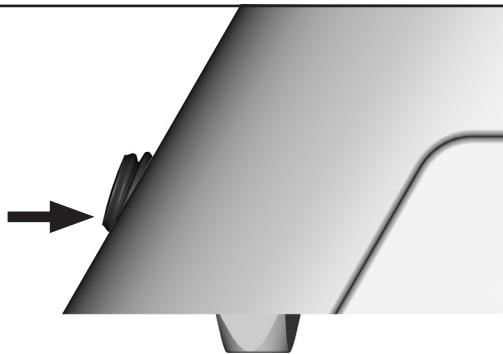

System switched off



System switched on



Attention: Operate the on/off switch only by hand.

Use and operation

First steps: Installation

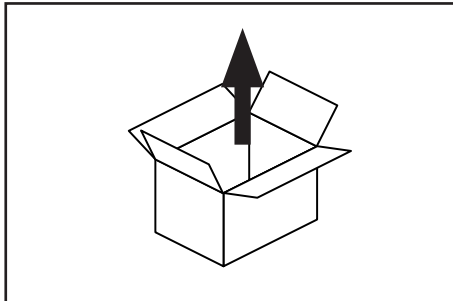

Unpack the equipment.



Read and comply with the document **”Safety information for vacuum equipment - Sicherheitshinweise für Vakuumgeräte”!**

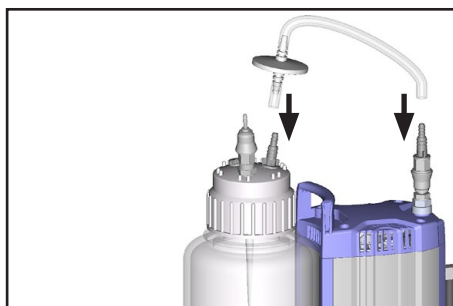

Assemble tubing with filter.



Only BVC with quick coupling for connection of the VacuuHandControl VHC^{pro}

Connect quick plug to coupling.

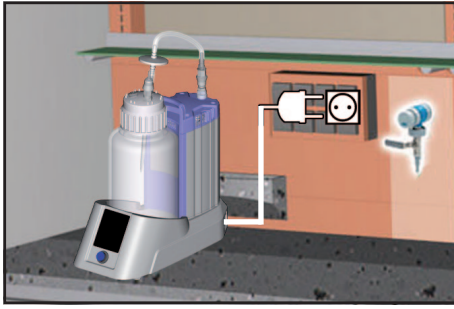

Setting up the BVC.

Connect to power supply.

⚠ CAUTION

Check line voltage and current prior to switching on!

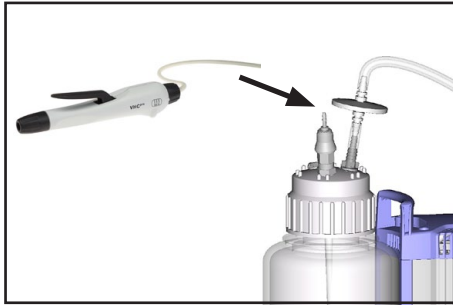

Attach tubing of the VacuuHandControl VHC^{pro} to the hose nozzle of the bottle head.

Operation BVC control / BVC control G



The unit has a touch panel so the keys need only be touched gently. Do not press the keys!

The keys “+” and “-” have to be touched > 0.25 seconds to be actuated.

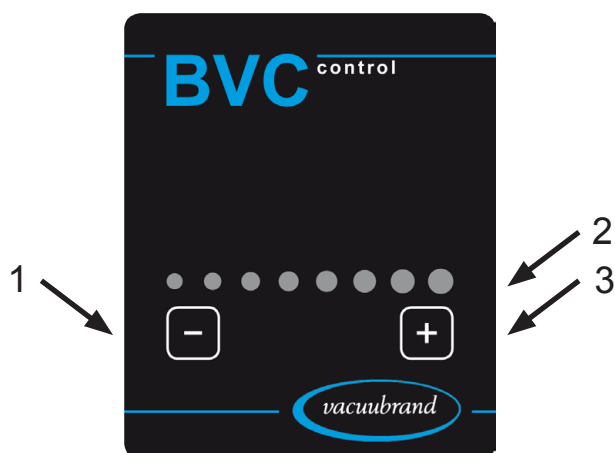
A successful action is confirmed by a blip and the flashing of LEDs.



Position	Designation
1	Key to reduce suction power
2	Display suction power
3	Key to increase suction power

-  Use the keys to set suction power of the system. The suction power can be set linearly in a range from 150 mbar (1 LED flashes) to 850 mbar (8 LEDs flash) underpressure (relative to atmospheric pressure).
- 

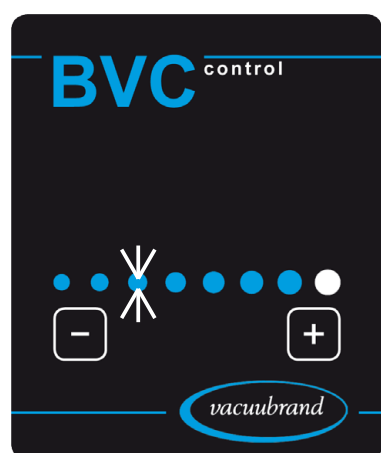

A **flashing LED** indicates that the actual available suction power differs from the preset suction power.

Attention: If the collection bottle is under vacuum and the vacuum demand is reduced, the existing underpressure inside the bottle remains until the vacuum is reduced (pressure rises) by further aspiration or venting with the VHC^{pro}.

Venting the BVC: Press the lever of the VHC^{pro} or set the VHC^{pro} to continuous aspiration.

Operation BVC professional / BVC professional G

The unit has a touch panel so the keys need only be touched gently. **Do not press the keys!**



The keys “+” and “-” have to be touched > 0.25 seconds to be actuated. The other keys have to be touched > 0.5 seconds.

Touch the keys with LED **below** the LED.

A successful action is confirmed by a blip and the flashing of LEDs.



Position	Designation
1	Key to select bottle size and level sensor
2	Key to reduce suction power
3	Key “bottle change”
4	Display suction power
5	Key to increase suction power

-  Use the keys to set suction power of the system. The suction power can be set as underpressure (relative to atmospheric pressure) linearly in a range of 150 mbar (1 LED flashes) to 850 mbar (8 LEDs flash).
- 



A **flashing LED** indicates that the actual available suction power differs from the preset suction power.

Attention: If the collection bottle is under vacuum and the vacuum demand is reduced, the existing underpressure inside the bottle remains until the vacuum is reduced (pressure rises) by further aspiration or venting with the VHC^{pro}.

Venting the BVC: Press the lever of the VHC^{pro} or set the VHC^{pro} to continuous aspiration.

Notes regarding the setting of the suction power

Depending on ambient atmospheric pressure (depending on altitude or weather conditions) and on the vapor pressure of the media inside the collection bottle, the setting of a high underpressure (e. g., 850 mbar, 8 LEDs flash) may lead to continuous operation of the pump. In this case, a reduction of the suction power is recommended.

Example:

Ambient pressure in high altitudes or in a depression: 800 mbar.

Suction power set to 8 LED's, 850 mbar underpressure relative to ambient pressure.

Result: Pump is continuously running, the set pressure difference is never achieved.

Recommendation: Reduce suction power.

Setting suction power	Underpressure relative to atmospheric pressure / ambient pressure
1 LED	150 mbar
2 LED's	250 mbar
3 LED's	350 mbar
4 LED's	450 mbar
5 LED's	550 mbar
6 LED's	650 mbar
7 LED's	750 mbar
8 LED's	850 mbar



Use the keys to select the bottle size (2 liter glass bottle or 4 liter polypropylene bottle), and with it the activation of the corresponding level sensor. To operate the key "2l Glass" or "4l PP" touch the key > 1 second. The LED of the selected bottle flashes blue.



Use the key to turn off the level sensor alarm and to start or stop the pump during bottle change.

To operate the key "bottle change", touch the key below the LED > 0.5 seconds.

Level sensor of BVC professional / BVC professional G

The sensor foil is located on the bottle support.

The level sensor gives an alarm and switches off the pump to avoid an overfilling of the collection bottle, if the liquid level in the collection bottle reaches the height of the level sensor, approximately 80% of the maximum bottle capacity (grey marked range with bottle symbols on the sensor foil, both for the 2l or 4l bottle).

We recommend checking the function of the level sensor regularly (depending on operating conditions): Fill bottle with liquid, and confirm that the level sensor alarms. The initiation time of the level sensor is up to 10 seconds.

NOTICE

In case of false alarm (empty bottle or bottle less than 80% filled) it might be necessary to adjust the sensor using the individual bottle. (See section “Adjustment of the level sensor”.)

Strong electromagnetic fields may influence the alarm level of the capacitive measurement element.

Incrustations or other deposits on the bottle wall may influence the alarm level of the capacitive measurement element, see section “Cleaning”.

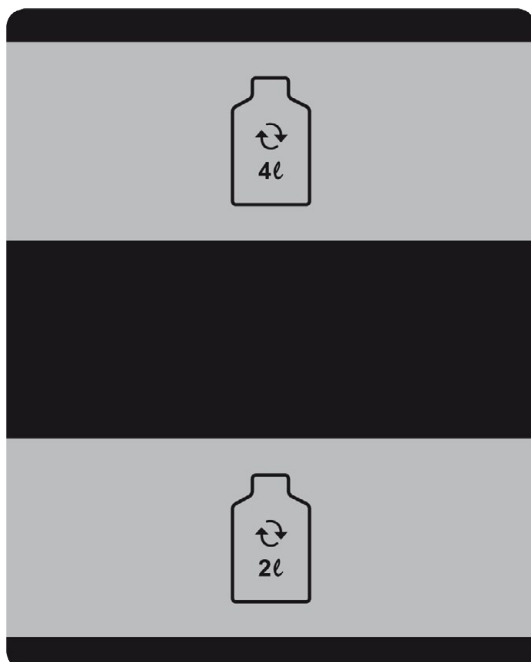

Level sensor range when selecting the 4l bottle

Level sensor range when selecting the 2l bottle

NOTICE

Use only the original VACUUBRAND BVC bottle or the original spare bottle (see “Accessories - Spare parts”).

Do not fix adhesive foil or something near it at the bottle side next to the sensor foil or directly at the sensor foil.

During operation

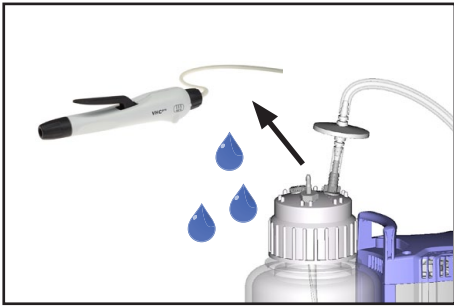

! DANGER

- ➔ Attention: When removing the aspiration controller VHC^{pro} liquid in the tube may leak! Adopt suitable measures to prevent the release of dangerous, toxic, explosive, corrosive, noxious or polluting fluids, vapors and gases. In such cases, use an appropriate collecting and disposal system and take protective action for personnel, equipment and environment.

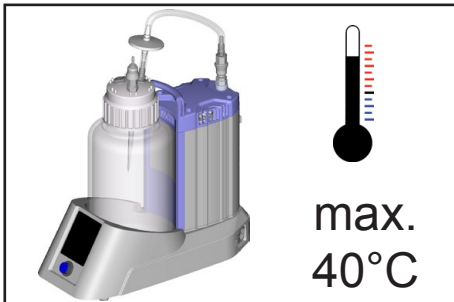

! WARNING

- ☞ **Max. ambient temperature: 40 °C**

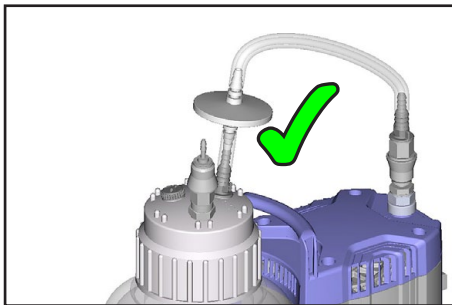

! CAUTION

- Use the system only with the **integrated hydrophobic filter** to protect the vacuum supply from aspirated liquids and aerosols, and to protect the environment/user from contamination risk.

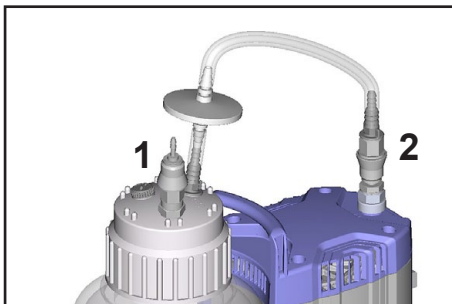

NOTICE

The BVC professional (with 4l polypropylene bottle) is equipped with quick couplings at the bottle head (1) and at the inlet of the pump (2). Quick couplings for other versions are available as accessories. (See section “Accessories - Spare parts“.)

Quick coupling set (1): VHC^{pro} to bottle:
When disconnected, the collection bottle closes vacuum tight.

Quick coupling set (2): Bottle to pump unit:
When disconnected, the collection bottle closes vacuum tight.

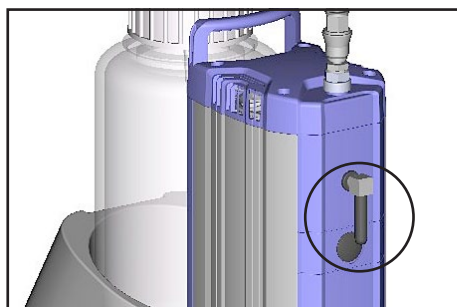

Silencer at the outlet

Attention: Dust-laden gases, deposits and condensed solvent vapor can restrict air flow out the silencer. The resultant back pressure can lead to damage of pump bearings, diaphragms, and valves. Under those conditions, a silencer must not be used. Check the silencer regularly and replace if necessary.

In case of harmful / poisonous gases or condensate at the outlet, remove silencer and replace with an exhaust tube.

NOTICE

The VHC^{pro} allows the aspiration of excess liquids. See manual "VacuuHandControl VHC^{pro}".

The aspiration system doesn't feature an air admittance valve. If the collection bottle is under vacuum and the vacuum demand is reduced, the existing underpressure inside the bottle remains until the vacuum is reduced (pressure rises) by further aspiration with the VHC^{pro}.

Attention: Removing the connection tubing from the screw cap leads to immediate venting of the collection bottle. In systems without quick couplings, removal of the tubing at the pump inlet will also vent the system.

Filtration

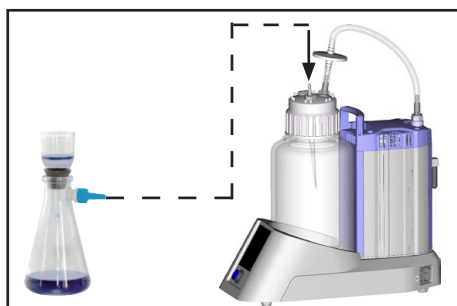

Connect the suction flask to the connection of the VHC^{pro} at the bottle head or via additional hose nozzle (cat. no.: 638509, section "Accessories), see section "Assembling a hose nozzle at the bottle head of the BVC".

NOTICE

The pump achieves its **pumping speed, ultimate vacuum** and vapor pumping rate only at operating temperature (after approx. 15 minutes).

Prevent internal condensation, transfer of liquids or dust. The diaphragm and valves will be damaged, if liquids are transferred through the pump in significant amounts.

In case of excess temperature the motor is shut down by a **thermal cutout** in the winding. Manual reset is necessary. Switch off or unplug the pump. Identify cause of failure and eliminate. Wait approx. five minutes before restarting the pump.

Attention: In case of **supply voltage below 100V** (100-120V version), the lock of the cutout might be restricted and the pump might restart on its own after sufficient cooling down. Take suitable precautions if an automatic restart of the pump may lead to a critical dangerous situation.

After a power failure, the system will automatically start again.

Shutdown

NOTICE**Short-term:**

Empty bottle.

Has the pump been exposed to **condensate**?

Set the VHC^{pro} to continuous aspiration and the BVC to maximum underpressure and allow the pump to continue to run for a few minutes.

Has the pump been exposed to media which may damage the pump materials or form **deposits**? Check and clean pump head if necessary.

Long-term:

Take measures as described in short-term shutdown section.

Close inlet and outlet port (e. g., with transport caps).

Store the pump in dry conditions.

Filter and collection bottle

NOTICE

The hydrophobic filter retains water and aqueous solutions also in the form of aerosols. When using solvents or due to evaporation of water, formation of condensate at the outlet of the BVC is possible.

WARNING

☞ **Important:** Comply with applicable regulations when disposing of solvents.

☞ **Attention:** Do not remove connections in case of liquid in the tube. Do not touch contaminated parts when removing the screw cap. Risk of infection! Wear appropriate protective clothing, e.g., gloves.

Filter



Change filter if necessary in case of contamination, weak aspiration or no aspiration.

☞ Use only the original spare part (see section “Accessories - Spare parts”) and sterilize and dispose of the filter according to appropriate regulations.

Note: After disinfection with alcohol, allow the filter to dry completely because the filter may become clogged by alcohol.

Emptying the collection bottle of the BVC control and BVC control G

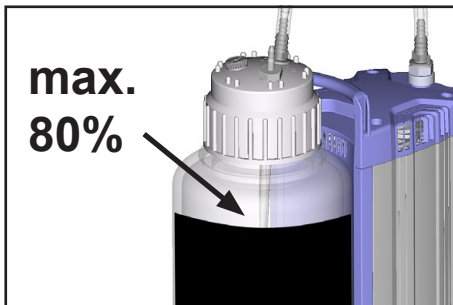

Check liquid level in the collection bottle regularly.

Maximum admissible liquid level in collection bottle: approx. 80 %, depending on the application. (In case of low boiling liquids or in case of suction of liquids which tend to foam, the admissible liquid level might be reduced.)



Switch off the BVC.

Vent the collection bottle.

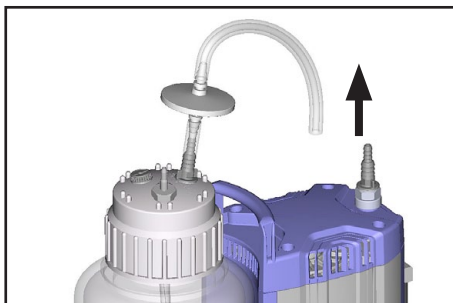

Remove the connecting tube at the pump inlet, isolate connections in case.

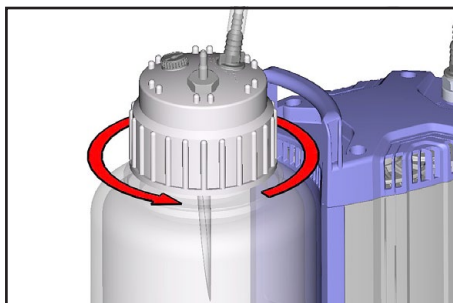

Remove screw cap from the collection bottle after venting.



Remove bottle from the support.

Sterilize and dispose of collected liquid according to appropriate regulations.

Emptying the collection bottle of the BVC professional and BVC professional G

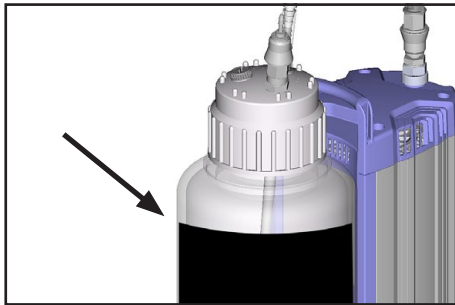

Check liquid level in the collection bottle regularly.

Maximum admissible liquid level in collection bottle: approx. 80 %, depending on the application. (In case of low boiling liquids or in case of suction of liquids which tend to foam, the admissible liquid level might be reduced.)

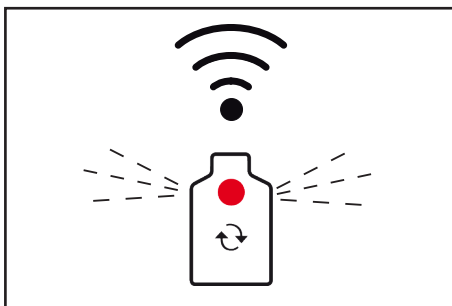

The **level sensor** switches off the pump at a liquid level of approx. 80% of capacity if correctly adjusted and if the correct bottle size is selected. This is indicated by “blips” and by a red LED inside of the bottle symbol on the “bottle change” key. Due to the underpressure inside the bottle, further aspiration is possible for a short time.

Disinfection routine

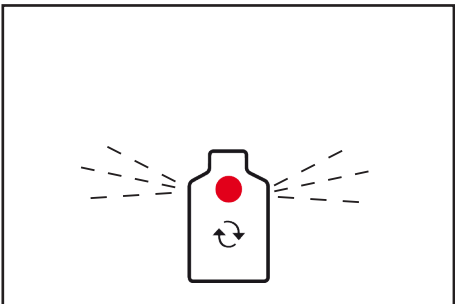

Touching the key below the LED switches off the blips and activate the pump, the LED is still flashing.

It is possible to aspirate for 3 minutes more, until the alarm is activated again and the pump is switched off again, e. g. for suction of disinfectants. Attention: Ensure to not overfill the bottle. The action is repeatable.

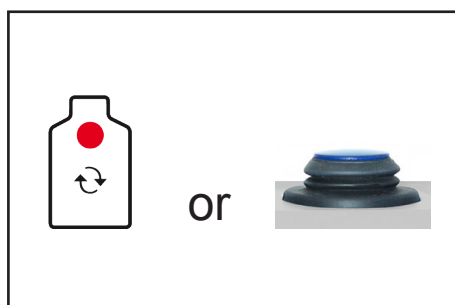

Touch the key prior to changing the collection bottle (red LED changes from flashing to glowing) or switch off the BVC, to avoid running of the pump while no bottle is connected.

NOTICE

When removing the tubing at the pump, the pump stops automatically (only BVC professional).



Vent the collection bottle.

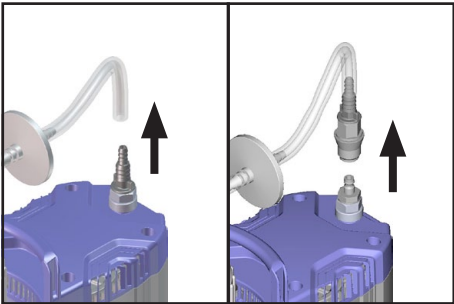

Remove the tubing at the inlet of the pump or disconnect coupling.

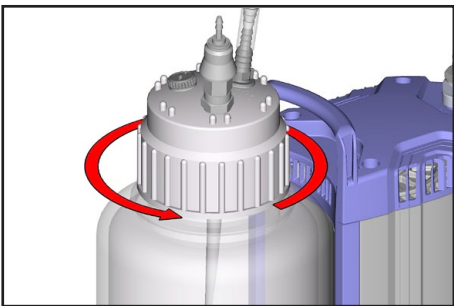

Remove screw cap from the collection bottle after venting.



Remove bottle from the support.

Sterilize and dispose of collected liquid according to appropriate regulations.

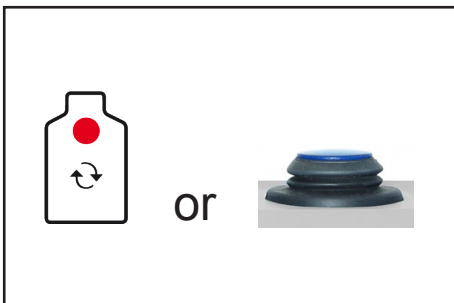

NOTICE

After changing the bottle touch the key to restart the pump or switch on the pump.

Cleaning and decontaminating

CAUTION

Over time, discoloration and material changes (e.g., resiliency, elasticity / tightness, cracking) due to repeated steam sterilizations / autoclavings and / or chemical disinfections may occur.

Check all parts regularly. Replace defective parts.

Autoclaving



Autoclaving

The collection bottle with bottle head and screw cap, the quick coupling and the filter are designated for steam sterilization at 121°C and 2 bar absolute (1 bar overpressure). Time of exposure according to DIN 58946 $t_e = 20$ minutes.

NOTICE

Prior to autoclaving loosen or remove the bottle head from the bottle.

It is the user's responsibility to ensure effective autoclaving.

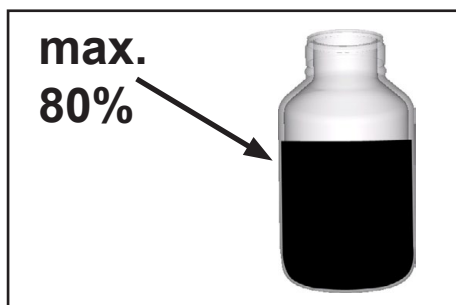

NOTICE

Autoclaving

Maximum liquid level in collection bottle: 80%. When working with low boiling liquids or liquids that tend to foam, the maximum liquid level may be less.

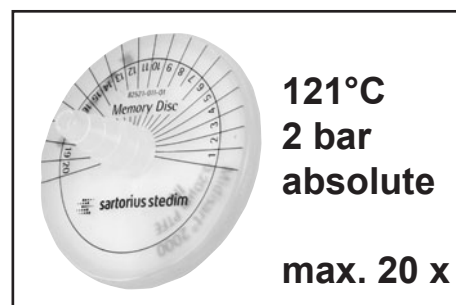

The number of autoclaving cycles can be marked on the plastic disc (Memory Disc) of the filter (max. 20 autoclaving cycles according to the manufacturer instruction).

Disinfection

NOTICE

UV disinfection is permitted but may lead to discoloration of the plastic parts.

Attention: UV disinfection acts only at the surface.

Important notes on use of disinfectants, see also “Safety during operation”

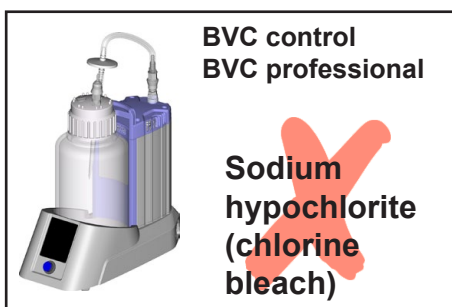

Aggressive disinfectants which release chlorine or oxygen radicals, e.g., sodium hypochlorite (chlorine bleach) or peroxide compounds can corrode the material of the 4l polypropylene collection bottle and other components (e.g., couplings). This may lead to stress cracks and breakage of the 4l polypropylene bottle.

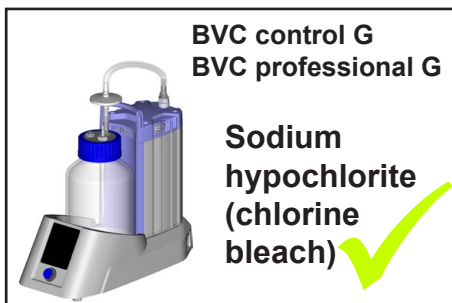

☞ Therefore, prolonged use of these disinfectants in the 4l polypropylene bottle is strongly discouraged. After brief disinfecting operations in the bottle, rinse bottle thoroughly to avoid leaving residues of disinfectant in the bottle.

➡ Alternative: Use the BVC control G / BVC professional G with 2l borosilicate glass bottle.

Attention: The quick-coupling accessory sets between the pumping unit and VHC^{pro} are not suitable for use with sodium hypochlorite (chlorine bleach).

CAUTION

- ☞ Using corrosive disinfectants may result in damage, malfunction and/or failure of the equipment.
- ☞ Chlorine permeates the hydrophobic filter on top of the collection bottle and may damage the materials of the equipment or the vacuum supply.
- ☞ Leaking of liquid from a damaged collection bottle or suction tube may lead to exposure of personnel and material or to damage/destruction of wetted equipment or laboratory furniture.

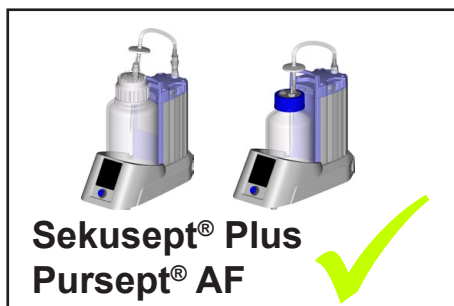

The use of the disinfectant **Sekusept® Plus** (Manufacturer: Ecolab GmbH & Co OHG, Düsseldorf, Germany) or **Pursept® AF** (Manufacturer: Schülke & Mayr GmbH, Norderstedt, Germany) in extensive in-house testing did not cause any damage to the collection bottle. Hence the disinfectant Sekusept® Plus - even when used in the collection bottle during suction - is preferred to sodium hypochlorite (chlorine bleach). Comply with use and safety instructions of the manufacturer!

Pursept® AF is available from BRAND GMBH + CO KG (www.brand.de / www.brand.en) via laboratory products distributors.

- ☞ Even if using disinfecting solutions **after termination of the suction** it is absolutely necessary to assure the compatibility of disinfectant and the parts to be disinfected.
- ☞ For information about the compatibility with the materials of the pumping unit, ask the manufacturer of the disinfectant.
- ☞ The wetted materials of the system are listed in the section "Technical data".

Cleaning

Incrustations or other deposits on the bottle wall of the BVC collection bottle may influence the alarm level of the capacitive measurement element of the level sensor of the **BVC professional / BVC professional G**.

The level alarm may occur too early, too late or not at all.
An adjustment of the level sensor is not performed correctly.

Therefore the bottle has to be cleaned before reuse.

Cleaning is possible e. g., mechanically with a brush or with the cleaning agent Mucapol[®], manufactured by Schülke & Mayr GmbH, Norderstedt, Germany.

Mucapol[®] is a liquid, alkaline high-performance concentrate for immersion and ultrasonic baths. According to manufacturer's data items are cleaned in ~ 10 – 30 minutes, without mechanical help.

Mucapol[®] is available from BRAND GMBH + CO KG (www.brand.de / www.brand.en) via laboratory products distributors.

To clean polypropylene bottles in laboratory dishwashers the cleaning agents neodisher[®] LaboClean FT and neodisher[®] LaboClean GK, manufactured by Chemische Fabrik Dr. Weigert GmbH & Co. KG, Hamburg, Germany, are suitable according to manufacturer's data.

Comply with material safety data sheets and notes on safe use of the manufacturer.

Adjustment of the BVC level sensor to work properly with a new bottle, or to correct false alarms

Pertains only to the BVC professional / BVC professional G

NOTICE

At the factory, the level sensor is adjusted either to the 4l polypropylene bottle or to the coated 2l glass bottle (G version) at standard conditions. It may be necessary to adjust the sensor to compensate for changes in bottle material, bottle size or changed ambient conditions.

NOTICE

We also recommend emptying the bottle and adjusting the BVC professional if there is a false alarm indicating “liquid level” even though the bottle is less than 3/4 full.

- ➔ If there is a false alarm in spite of an adjustment, repeat the adjustment.
- ➔ If there is a false alarm in spite of **repeated adjustment**, please call +49 9342 808-5500 (after sales service), or your local VACUUBRAND sales office.

NOTICE

Use only the original VACUUBRAND BVC bottle or the original spare bottle (see “Accessories - Spare parts”).

Attention: When performing an adjustment, the bottle has to be clean and free of incrustations or other deposits, see section “Cleaning”.

Perform an adjustment only with a clean, empty and dry bottle.



NOTICE

Do not attach adhesive foil or anything similar to level sensor or to the side of the bottle directly next to the sensor.

Preparation

- 1. Empty the bottle, decontaminate in case, clean and dry.**
 - 2. Position the bottle in the BVC.**
 - 3. Connect the bottle via hose to the pump.**
 - 4. Switch on the BVC.**
- ➡ **To shut off a false alarm prior to an adjustment, simply touch the key marked “bottle change.” The red LED will continue to flash.**

Adjustment routine for BVC professional with 4l polypropylene bottle from software version V1.9, see rating plate

Adjustment routine for older software versions: See “Instructions for adjustment of the liquid level sensor” on www.vacuubrand.com.



Attention: Do not interrupt the adjustment routine once you have begun, even if there is an alarm. Complete the entire routine, and repeat if necessary.

Adjustment routine may take up to 3 minutes.

During adjustment all keys are without function.

Switching off the BVC during adjustment routine terminate the adjustment. The level sensor retains the original adjustment values.

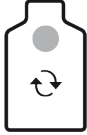
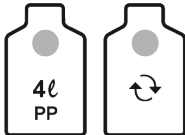
Action	Reaction	Meaning
<p>Step 1</p> <p>Touch and hold “4l P” key.</p> 	<p>Case 1:</p> <p>The LED of the “4l PP” bottle symbol flashes blue.</p> <p>Case 2 / false alarm:</p> <p>The alert tone for the false alarm is shut off.</p> <p>The LED of the “4l PP” bottle symbol flashes blue.</p>	<p>Adjustment is possible by continuing to hold the “4l PP” key, and proceeding to step 2.</p>
<p>Step 2</p> <p>When the LED of the “4l PP” key flashes blue, touch and hold the “bottle change” key at the same time.</p> 	<p>A one-time buzzer sounds.</p> <p>The pump stops.</p> <p>After the buzzer, the LED of the “bottle change” key lights red.</p>	
<p>Step 3</p> <p>Release both “4l PP” key and “bottle change” key.</p> 	<p>The LED of the “4l PP” bottle symbol flashes blue.</p> <p>All LED’s of the suction power display flash blue.</p> <p>The LED of the “bottle change” key lights red.</p>	<p>Adjustment is running.</p>

Action	Reaction	Meaning
	<p>Case 1: After max. 3 minutes:</p> <p>The LED of the “4l PP“ bottle symbol lights blue.</p> <p>The LED’s of the suction power display stop flashing.</p> <p>The red LED of the “bottle change” key goes out.</p> <p>The pump starts.</p>	Adjustment successful.
	<p>Case 2: After max. 3 minutes:</p> <p>All LED’s light.</p> <p>All keys are without function.</p> <p>The pump doesn’t start.</p>	Adjustment not successful.
<p>Only if “Adjustment not successful.”</p> <p>Step 4 Switch off the BVC.</p>	All LED’s go out.	The level sensor retains the original adjustment values.
<p>Step 5 Switch on the BVC.</p>	The pump starts.	<p>Repeat adjustment.</p> <p>If adjustment is not successful after several attempts, please call +49 9342 808-5500 (after sales service), or your local VACUUBRAND sales office.</p>

Adjustment routine for BVC professional with 2l glass bottle

from software version V1.9, see rating plate

Adjustment routine for older software versions: See “Instructions for adjustment of the liquid level sensor” on www.vacuubrand.com.





Attention: Do not interrupt the adjustment routine once you have begun, even if there is an alarm. Complete the entire routine, and repeat if necessary.

Adjustment routine may take up to 3 minutes.

During adjustment all keys are without function.

Switching off the BVC during adjustment routine terminate the adjustment. The level sensor retains the original adjustment values.

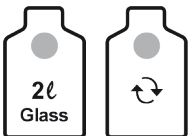
Action	Reaction	Meaning
<p>Step 1 Touch and hold “2l Glass” key.</p> 	<p>Case 1: The LED of the “2l Glass” bottle symbol flashes blue.</p> <p>Case 2 / false alarm: The alert tone of the false alarm is shut off. The LED of the “2l Glass” bottle symbol flashes blue.</p>	Adjustment is possible by continuing to hold the “2l Glass” key, and proceeding to step 2.
<p>Step 2 When the LED of the “2l Glass” key flashes blue, touch and hold the “bottle change” key at the same time.</p> 	<p>A one-time buzzer sounds.</p> <p>The pump stops.</p> <p>After the buzzer, the LED of the “bottle change” key lights red.</p>	
<p>Step 3 Release both “2l Glass” key and “bottle change” key.</p> 	<p>The LED of the “2l Glass” bottle symbol flashes blue.</p> <p>All LED’s of the suction power display flash blue.</p> <p>The LED of the “bottle change” key lights red.</p>	Adjustment is running.

Action	Reaction	Meaning
	<p>Case 1: After max. 3 minutes:</p> <p>The LED of the “2l Glass“ bottle symbol lights blue.</p> <p>The LED’s of the suction power display stop flashing.</p> <p>The red LED of the “bottle change” key goes out.</p> <p>The pump starts.</p>	Adjustment successful.
	<p>Case 2: After max. 3 minutes:</p> <p>All LED’s light.</p> <p>All keys are without function.</p> <p>The pump doesn’t start.</p>	Adjustment not successful.
<p>Only if “Adjustment not successful.”</p> <p>Step 4 Switch off the BVC.</p>	All LED’s go out.	The level sensor retains the original adjustment values.
<p>Step 5 Switch on the BVC.</p>	The pump starts.	<p>Repeat adjustment.</p> <p>If adjustment is not successful after several attempts, please call +49 9342 808-5500 (after sales service), or your local VACUUBRAND sales office.</p>

Assembling of components

Replacing the filter

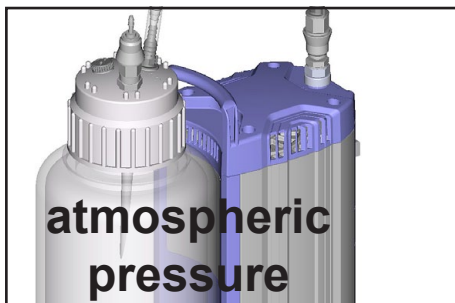

Vent the collection bottle.
Ensure that there is no liquid in the tube to avoid risk of contamination.

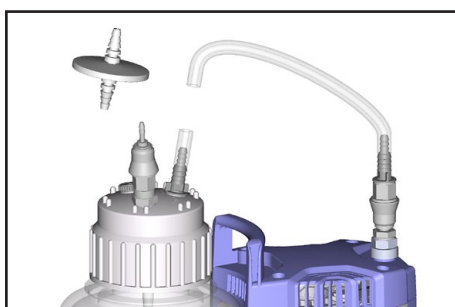

Remove connecting tube from the filter. Remove the filter from the piece of tube at the hose nozzle.

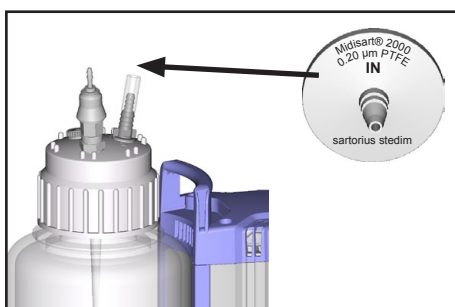

Attach new filter.

Observe flow direction. Position filter with the printed side "IN" towards the bottle.

Attach the connecting tube.

Assembling a second VHC^{pro} connection set (with / without coupling) or conversion to quick coupling VHC^{pro} - bottle)

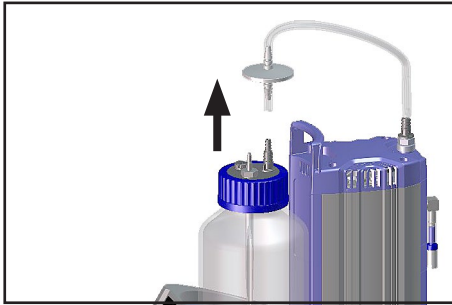

Empty bottle.
Decontaminate equipment if necessary.

Remove filter with connection tubing from bottle head.

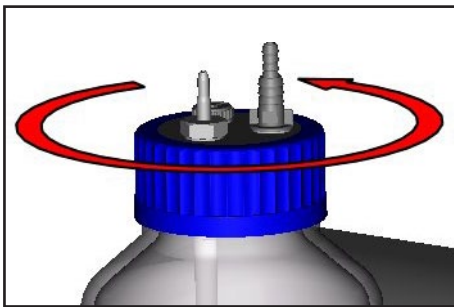

Remove screw cap from the collection bottle.

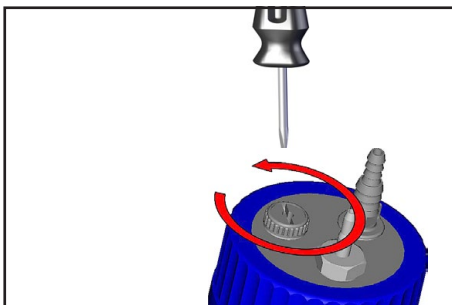

Unscrew closing screw.
Only BVC with polypropylene bottle: Remove counter nut inside the screw cap.



Only BVC with polypropylene bottle: Remove counter nut inside the screw cap.

BVC with glass bottle

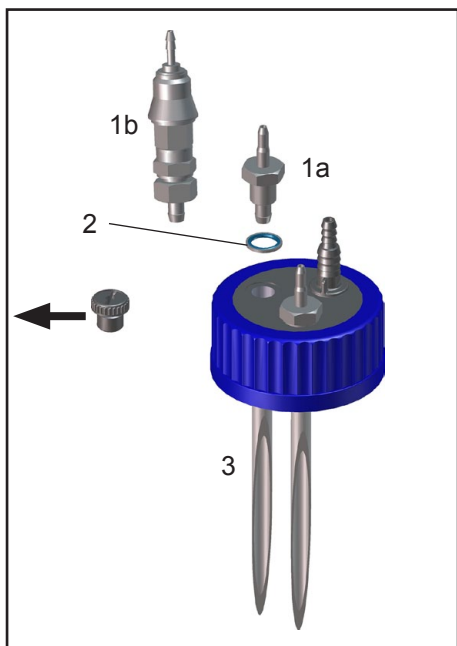

Screw hose connection (1a) with seal ring (2) or coupling (1b) with seal ring (2) into the screw cap.

Assemble hose (3) under the screw cap to the lead through.

BVC with polypropylene bottle

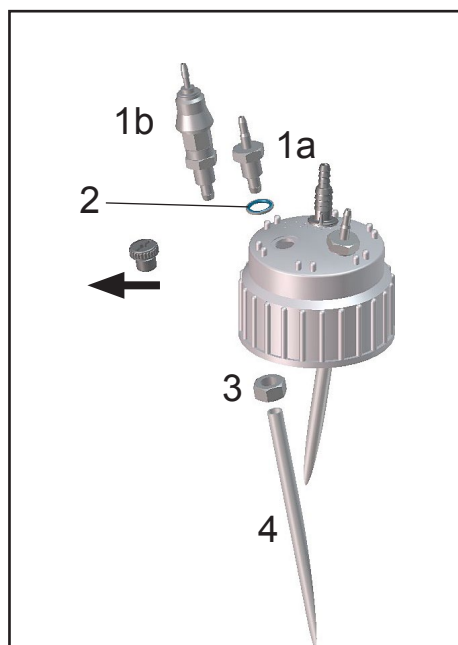

Insert hose connection (1a) with seal ring (2) or coupling (1b) with seal ring (2) in the screw cap. Secure lead through with counter nut (3). Assemble hose (4) under the screw cap to the lead through.

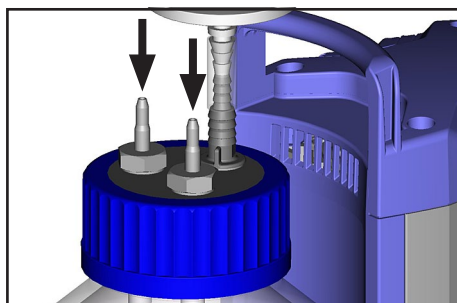

Screw screw cap to bottle.

Assemble filter.

Assemble VHC^{pro}.

Assembling quick coupling bottle - pump unit (extension set)

Attention: The extension set “Quick coupling bottle - pump unit” is designated for two different extension versions. Therefore the set consists of parts which may not be necessary in each individual case.

Redundant parts are not credited by VACUUBRAND.

Assembling to pump inlet

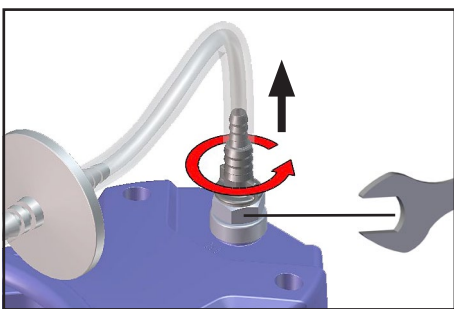

Remove tubing.

Disassemble hose nozzle.

Hold counter piece with open-ended wrench size 19 mm.

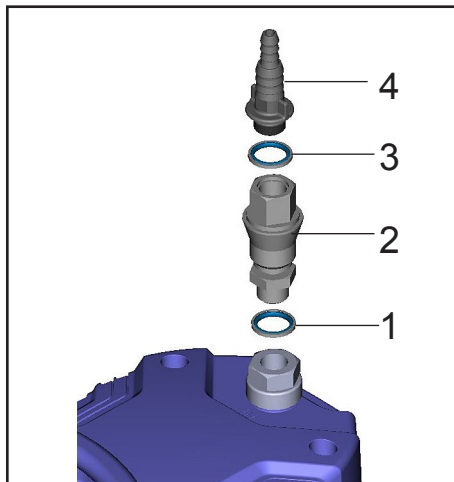

Assemble coupling (2) with seals (1, 3) and hose nozzle (4).

Hold counter piece with open-ended wrench size 19 mm.

Connect tubing.

Assembling to an additional bottle

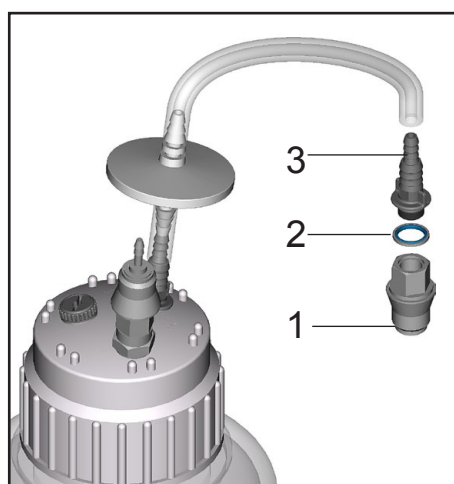

Assemble coupling part (1) with seal (2) and hose nozzle (3).

Connect tubing.

Assembling a hose nozzle at the bottle head of the BVC

Hose nozzle (638509), see “Accessories”, e.g., for filtration applications
Empty bottle.

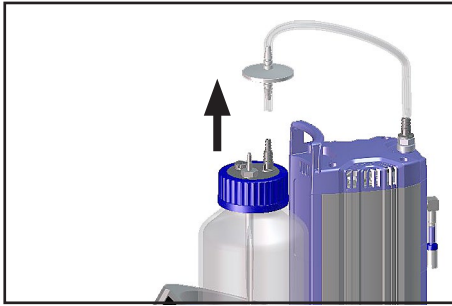

Decontaminate equipment if necessary.

Remove filter with connection tubing from bottle head.

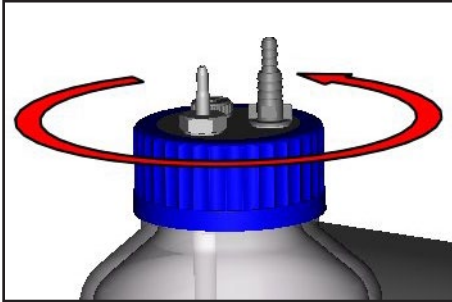

Remove screw cap from the collection bottle.

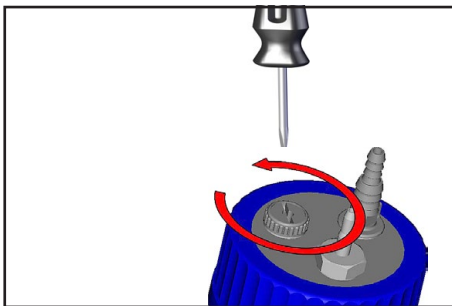

Unscrew closing screw.

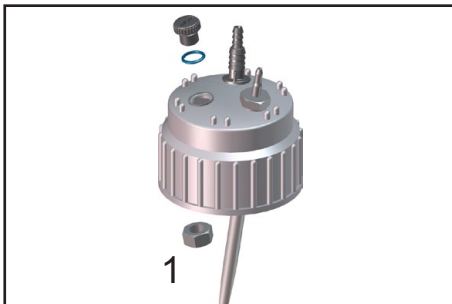

Only BVC with polypropylene bottle: Remove counter nut (1) inside the screw cap.

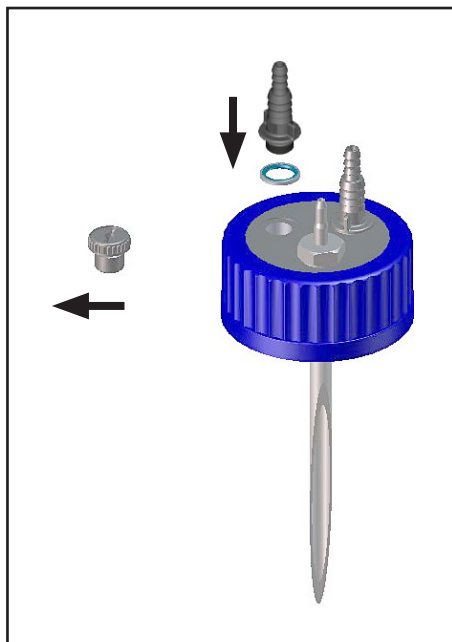

Screw hose nozzle with seal ring into the screw cap.

Only BVC with polypropylene bottle: Secure hose nozzle with counter nut.

Screw screw cap to bottle.

Assemble filter.

If necessary, close unused connections.

Quick coupling sets

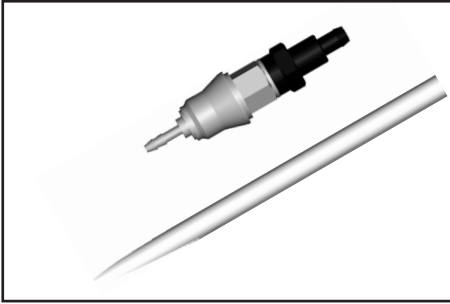

Quick coupling set: VHC^{pro} to bottle

Quick coupling made of PVDF, with adapter to connect a VHC^{pro} to a collection bottle. When disconnected, the collection bottle closes vacuum tight.

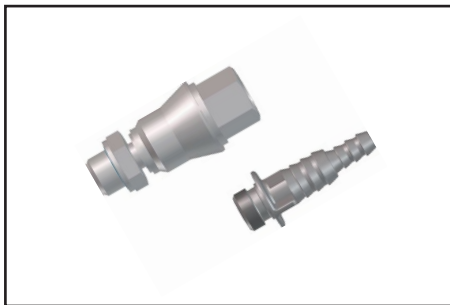

Quick coupling set: Bottle to pump unit

Quick coupling made of PVDF, to connect a collection bottle to a BVC basic / basic G. When disconnected, the collection bottle closes vacuum tight.

NOTICE

Attention: The quick-coupling accessory sets between the pumping unit and VHC^{pro} are not suitable for use with sodium hypochlorite (chlorine bleach).

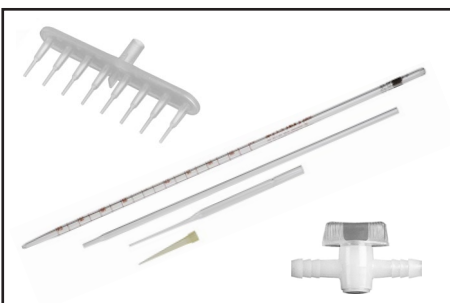

Pipettes or pipette tips, 8-channel manifold as well as straight-bore stopcocks with nozzles are available from BRAND GMBH + CO KG (www.brand.de/en) via laboratory products distributors.

Accessories - spare parts

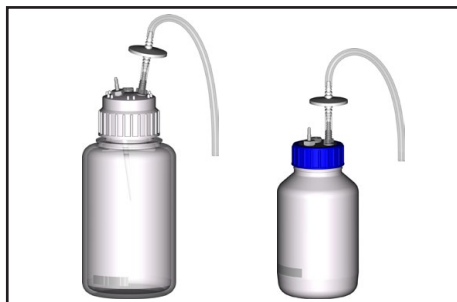

Collection bottle 4L, made of PP,
with protection filter and inlet tube..... **635810**

Collection bottle 2L glass, coated,
with protection filter and inlet tube..... **635809**

Attention: Please order quick-couplings separately!



Collection bottle 4L, made of PP,
for BVC professional with quick coupling,
protection filter and inlet tube **635578**



Bottle 4L PP, with cap unmachined
(w/o filter, connection for hose, blind plug)..... **638246**

Bottle 2L glass, with cap unmachined
(w/o filter, connection for hose, blind plug)..... **635871**

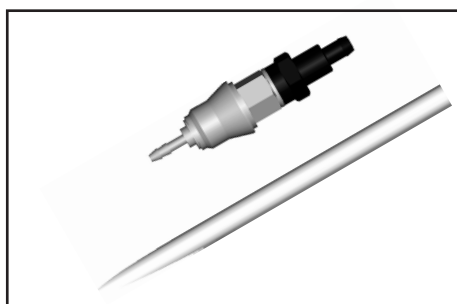

Set of quick-coupling for connection
VHC^{pro}-bottle including adapter and
inlet tube **635807**

Attention: The quick-coupling accessory sets between the bottle and the pumping unit as well as between the bottle and the hand controller are not suitable for use with sodium hypochlorite (chlorine bleach).

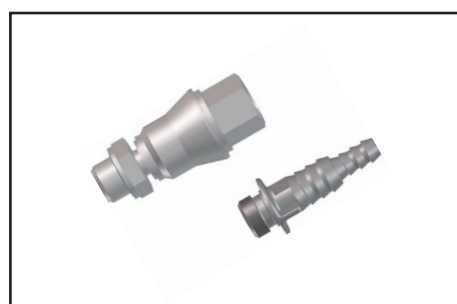

Set of quick-coupling for connection
bottle to pump **635808**

Attention: The quick-coupling accessory sets between the bottle and the pumping unit as well as between the bottle and the hand controller are not suitable for use with sodium hypochlorite (chlorine bleach).

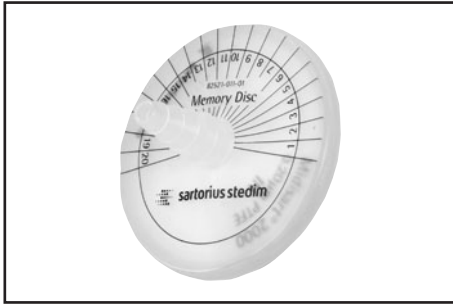

Protection filter with connection hoses638266

Silicone hose 12/6 mm (length in cm).....635741



VacuuHandControl VHC^{pro}688061

Spare hose for VHC^{pro}636156
(minimum order quantity 2 m)

Silicone hose 9/6 mm (length in cm).....638263
(bend protection)

Extension kit second VHC^{pro} connection699943
(to be assembled at a VACUUBRAND BVC, without VHC^{pro}, without quick coupling)

Hose nozzle DN 6/10mm, thread G1/4"638509

For further accessories and spare parts see instructions for use of the VHC^{pro}.



Adapter for pipette tips with tip ejector
..... **635638**
for pipette tips 2 - 200 µl



8-channel tip adapter with ejector
..... **635679**
for pipette tips 2 - 200 µl and 50 - 1000 µl



Adapter BVC for 2L glass bottle635839

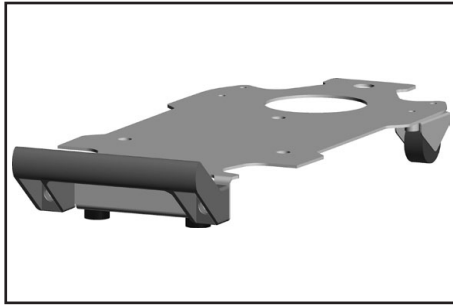

BVC shuttle.....696880
(mobile underframe for BVC)

Troubleshooting

Fault	Possible cause	Remedy
<input type="checkbox"/> Pump fails to start, system becomes vented.	<ul style="list-style-type: none"> ➔ Not plugged in, or failure of electrical supply? ➔ Power switched off? ➔ Motor overloaded? ➔ Internal fuse blown? ➔ Aspiration power setting is off (atmosphere, no vacuum)? ➔ Red LED glows continuously? ➔ Filter clogged? 	<ul style="list-style-type: none"> ✓ Plug in, or check fuse controlling power outlet. ✓ Switch on power. ✓ Switch off, allow motor to cool, identify cause of failure and eliminate before switching on again. ✓ Identify cause of failure, replace fuse (under the cover). ✓ Set aspiration power to "+" (more vacuum). ✓ Eliminate leaks. ✓ Replace filter.
<input type="checkbox"/> No aspiration at the VHC ^{pro} , pipette drips (above causes excluded).	<ul style="list-style-type: none"> ➔ Adapter or aspiration tube defective? ➔ Filter clogged? ➔ Leak at the bottle head? ➔ Pump operating but no pumping speed? ➔ Aspiration power setting is off (atmosphere, no vacuum)? 	<ul style="list-style-type: none"> ✓ Replace adapter with aspiration tube. ✓ Replace filter. ✓ Check seals, coupling and blind cap. Screw in or replace if necessary. ✓ Perform maintenance, replace diaphragm and valves if necessary. ✓ Set aspiration power to "+" (more vacuum).
<input type="checkbox"/> Pump switches frequently.	<ul style="list-style-type: none"> ➔ Leak in the system? ➔ Filter clogged? ➔ Diaphragms or valves of the pump defective? 	<ul style="list-style-type: none"> ✓ Check tubing, seals, coupling, and blind cap. Screw in or replace if necessary. ✓ Replace filter. ✓ Perform maintenance, replace diaphragm and valves if necessary.

Fault	Possible cause	Remedy
<input type="checkbox"/> Pump is running continuously.	<ul style="list-style-type: none"> ➔ Leak in the system? ➔ Too high underpressure for altitude / weather conditions? Vapor pressure of the media inside the collection bottle too high? ➔ Other causes? 	<ul style="list-style-type: none"> ✓ Check tubing, seals, coupling, and blind cap. Screw in or replace if necessary. ✓ Reduce underpressure / aspiration power. ✓ Contact your local distributor.
<input type="checkbox"/> Pump is running continuously, all LED's indicating the suction power are flashing.	<ul style="list-style-type: none"> ➔ Pressure sensor defective? 	<ul style="list-style-type: none"> ✓ Reduce suction power using key "-". If the error persists, contact your local distributor.
<input type="checkbox"/> Keys do not react.	<ul style="list-style-type: none"> ➔ Keys of the touch panel touched long-lasting? 	<ul style="list-style-type: none"> ✓ Wait 20 seconds and try again.
<input type="checkbox"/> Only BVC professional / G: Level sensor gives a false alarm or level alarm occurs too early, too late or not at all.	<ul style="list-style-type: none"> ➔ Bottle has been replaced or changed ambient conditions? ➔ Not using original VACUUBRAND BVC bottle? ➔ Adhesive foil at the collection bottle or the level sensor foil? ➔ Bottle wet (after cleaning or disinfection)? ➔ Bottle inside and/or outside with conductive coating (e.g., silver containing disinfectants)? ➔ Bottle inside and/or outside with deposits / incrustations? 	<ul style="list-style-type: none"> ✓ Adjust the level sensor. ✓ Use original VACUUBRAND BVC bottle or original spare bottle. ✓ Remove adhesive foil. ✓ Dry bottle. Adjust the level sensor. ✓ Clean bottle carefully and dry, see section "Cleaning". Adjust the level sensor. ✓ Clean bottle carefully and dry, see section "Cleaning". Adjust the level sensor.

Replacing diaphragms and valves

! DANGER



- ➔ **Never operate the pump if covers or other parts of the pump are disassembled.**
- ➔ Before starting maintenance, **disconnect the electrical power cord. Wait 5 seconds** after isolating the equipment from AC power to allow the capacitors to discharge.
- ➔ Ensure that the pump cannot be operated accidentally.
- ➔ **Note:** The pump might be contaminated with the process chemicals that have been pumped during operation. Ensure that the pump is decontaminated before maintenance.
- ➔ Avoid the release of pollutants.

! WARNING

- ☞ **Never operate a defective or damaged pump.**
- ☞ Take adequate precautions to protect people from the effects of dangerous substances that may have contaminated the pump and may be released upon disassembly. Ensure that the maintenance technician is familiar with the safety procedures which relate to the products processed by the pumping system. Use appropriate protective clothing, safety goggles and protective gloves.
- ☞ Check every motor capacitor regularly by measuring its capacity and estimating its service life. Replace old capacitors early enough to prevent a failure. The capacitors must be replaced by a trained electrician.
- ☞ Allow sufficient cooling of the pump before starting maintenance.
- ☞ **Vent the pump and isolate it from the vacuum system before you start maintenance.**

NOTICE

Ensure that maintenance is done only by suitably trained and supervised technicians.

The valves and diaphragms as well as the motor capacitors are wear parts. If the rated ultimate vacuum is no longer achieved or in case of increased noise level, the pump interior, the diaphragms and the valves must be cleaned and the diaphragms and valves must be checked for cracks or other damage.

All bearings are encapsulated and are filled with long-life lubricant. Under normal operating conditions, the drive system is maintenance free.

In demanding circumstances, it may be efficient to check and clean the pump heads on a regular basis. In normal use, the lifetime of the diaphragms and valves is more than 15,000 operating hours.

- Prevent internal condensation, transfer of liquids or dust. The diaphragms and valves will be damaged if liquid is pumped in significant amount.
- Carry out maintenance frequently if the pump is exposed to corrosive media or in case of deposits.
- Regular maintenance will improve the lifetime of the pump and also protect both users and the environment.

Set of seals BVC (1 diaphragm, 2 valves, diaphragm key).....**696879**

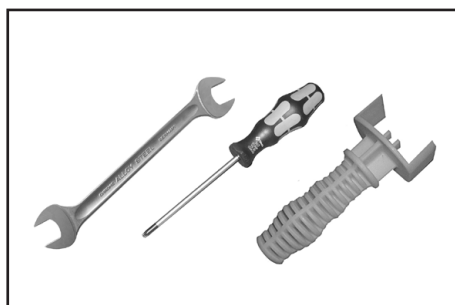
**Tools (metric):**

- Diaphragm key SW 46 (included in the set of seals)
- Screw driver Torx TX20
- Open-ended wrench SW 19

Please read section "Replacing diaphragms and valves" completely before starting maintenance.

The pictures may show other versions of pumps. This does not change the method of replacing diaphragms and valves.

Cleaning and inspecting the pump heads

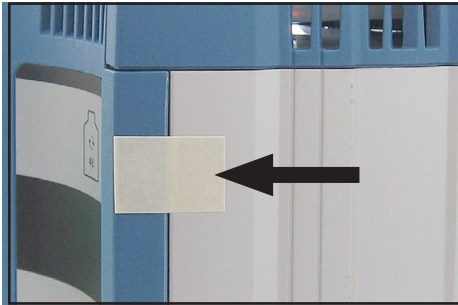

- Fix cover plate at the pump housing using adhesive tape.

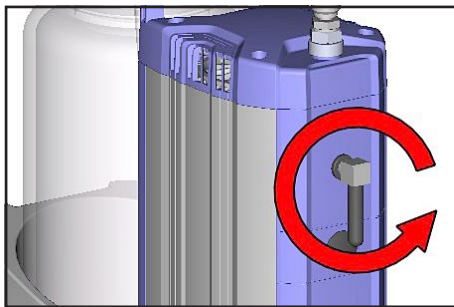

- Unscrew elbow fitting with silencer at the outlet of the pump.

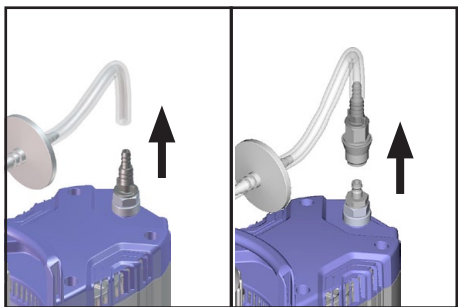

- Depending on BVC version, remove connection tubing at the hose nozzle or detach quick coupling.
- Remove bottle from support.

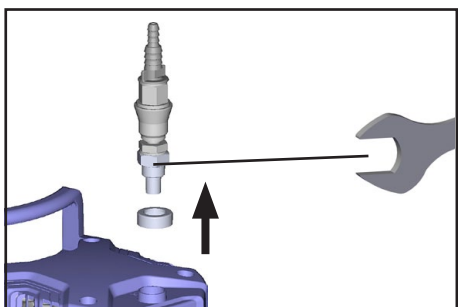

- Unscrew hose nozzle, or coupling with hose nozzle, using an open-ended wrench.

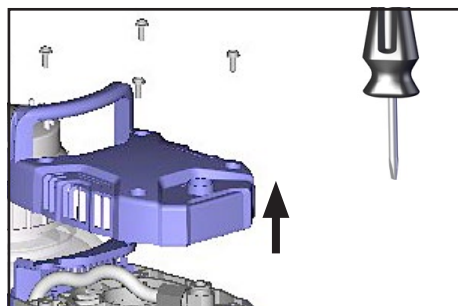

- Unscrew cover, paying attention to washers.

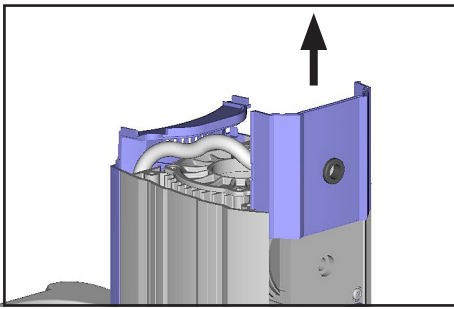

➡ Remove the cover of the housing cover from the housing.

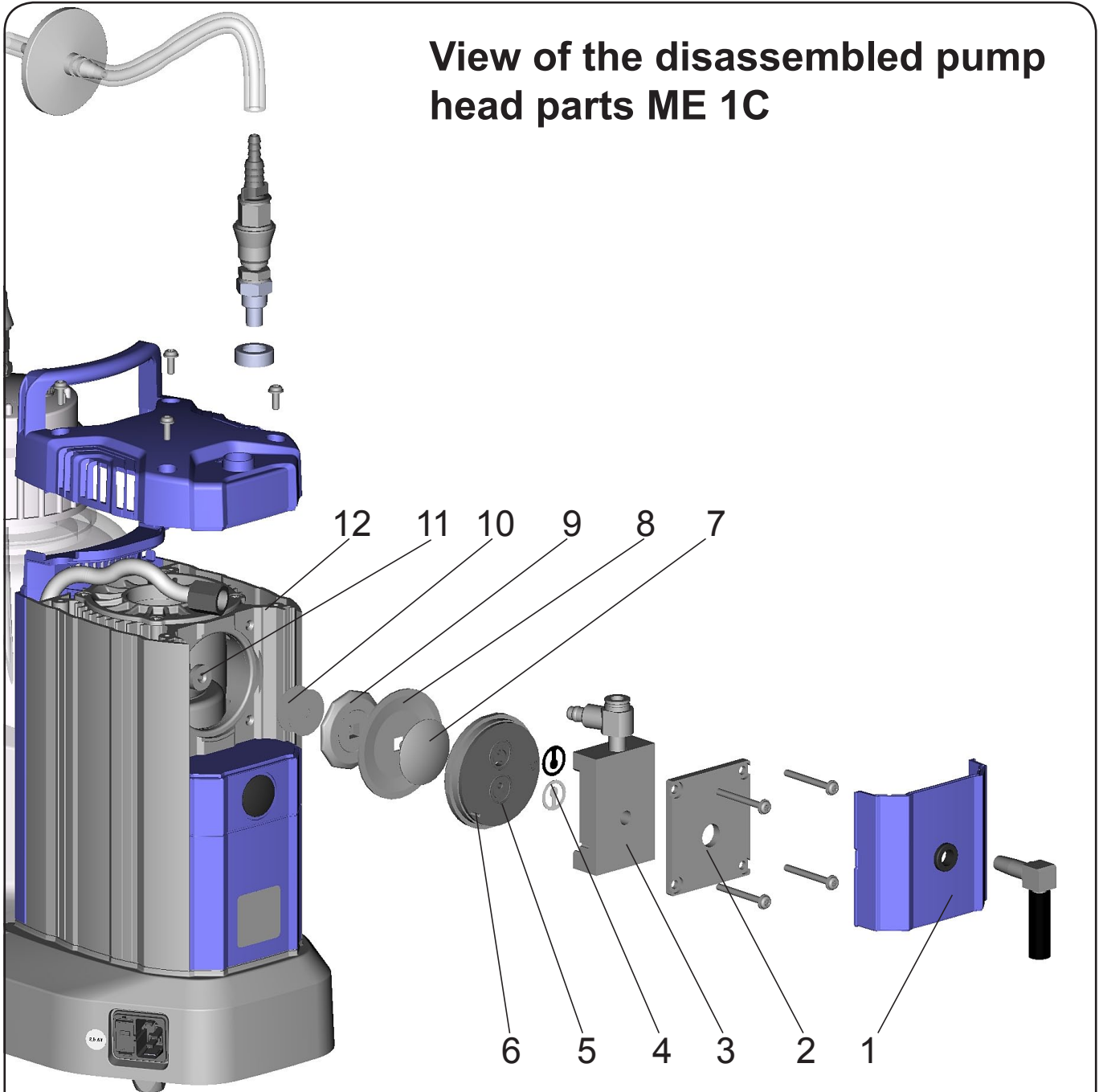

View of the disassembled pump head parts ME 1C

- 1: Cover of housing cover
- 2: Housing cover
- 3: Housing cover insert
- 4: Valves
- 5: Head cover
- 6: Guiding pin

- 7: Diaphragm clamping disc with square head screw
- 8: Diaphragm
- 9: Diaphragm support disc
- 10: Washers
- 11: Rod
- 12: Housing

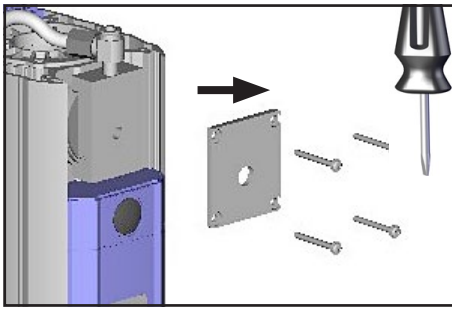

- ➔ Unscrew four screws at the pump head, paying attention to washers. Remove housing cover.

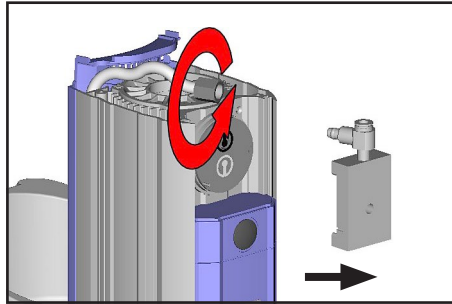

- ➔ Unscrew union nut and remove hose from elbow fitting. Remove housing cover insert with elbow fitting.

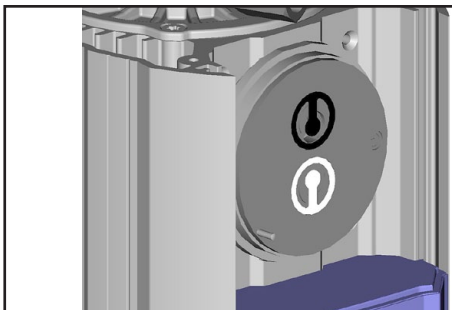

Note position of valves.
 Replace valves if necessary.
 Use petroleum ether or industrial solvent to remove deposits. Do not inhale vapors.

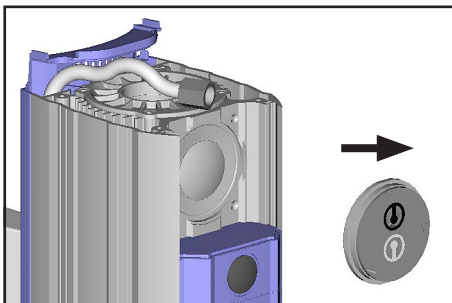

- ➔ Remove head cover and valves.
- ☞ Check diaphragm for damage and replace if necessary.
- ☞ Never remove parts by using a pointed or sharp-edged tool (e.g., screw driver), we recommend to use a rubber mallet or compressed air (to be blown carefully into port).

Replacing the diaphragm

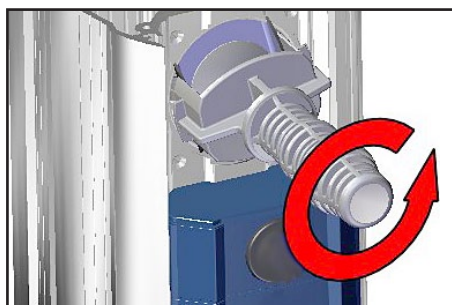

- ➔ Lift diaphragm carefully sidewise.
- ☞ Never use a pointed or sharp-edged tool to lift the diaphragm.
- ➔ Use the diaphragm key to grip the diaphragm support disc below the diaphragm. Press down the diaphragm clamping disc to bring the diaphragm to its lowest oscillating position. Unscrew diaphragm support disc with diaphragm and diaphragm clamping disc.

- ☞ If the old diaphragm is difficult to separate from the diaphragm support disc, immerse assembly in naphtha or petroleum ether. Do not inhale vapors!
- ☞ Check for washers between the diaphragm support disc and the connecting rod. Make sure that the original number is reassembled.

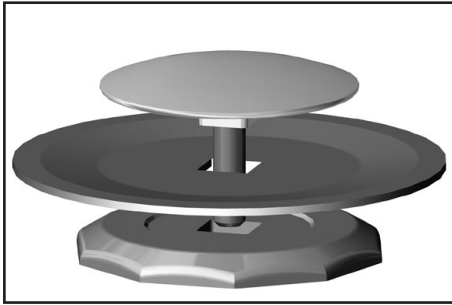

- ➔ Position new diaphragm between diaphragm clamping disc with square head screw and diaphragm support disc.
- ☞ **Note:** Position diaphragm with pale side towards diaphragm clamping disc (facing pump chamber).

- ☞ Make sure that the square head screw of the diaphragm clamping disc is correctly seated in the guide hole of the diaphragm support disc.

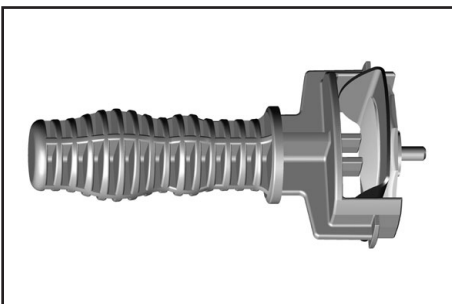

- ➔ Lift the diaphragm at the side. Place the diaphragm carefully together with diaphragm clamping disc and diaphragm support disc in the diaphragm key.

- ☞ Avoid damage of the diaphragm: Do not excessively bend or crease the diaphragm.
- ➔ Assemble the original number of washers between diaphragm support disc and connecting rod.
- ☞ Too few washers: The pump will not attain vacuum specification. Too many washers: Diaphragm clamping disc will hit head cover, causing noisy operation and possibly causing the pump to seize up.

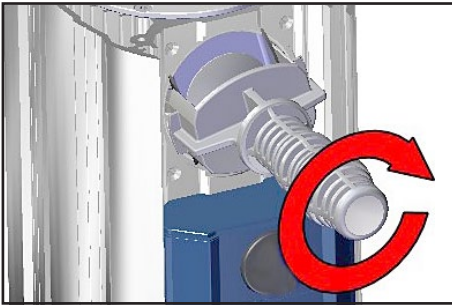

- ➔ Position any washers that are present between diaphragm support disc and connection rod.
- ➔ Screw diaphragm clamping disc, diaphragm, diaphragm support disc, and washers to connecting rod.
- ➔ Bring the diaphragm into a position in which it is in contact with the housing and centered with respect to the bore so that it will become clamped uniformly between housing and head cover.

Assembling the pump head

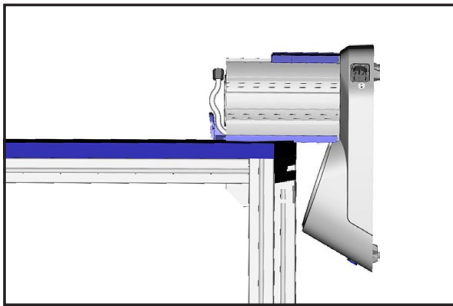

- ➔ Lay down the BVC on the side of the pump, e. g., at the edge of a workbench; support if necessary.

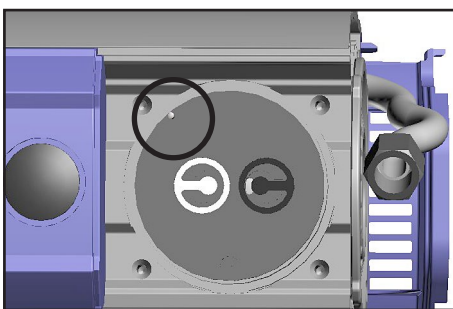

- ➔ Assemble head cover and valves.
- ☞ Pay attention to the correct position of the guidance pin in the head cover (circle in figure)!
- ☞ Pay attention to **correct orientation of the valves** (see figure):
 - Inlet side** of pump head (black valve): The valve tongue points at the kidney-shaped orifice in the valve seat.
 - Outlet side** of pump head (white valve): The valve is oriented the opposite direction as the valve at the inlet side. Round orifice under the valve tongue.

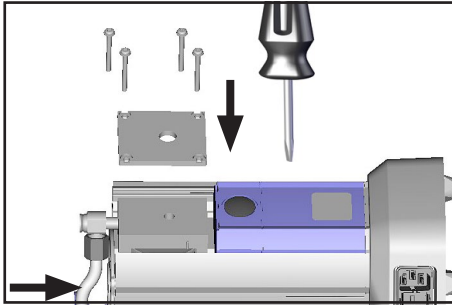

- Put on housing cover and housing cover insert.
- ☞ Move housing cover insert slightly to ensure that the head covers are correctly positioned.
- Pay attention to washers and position screws. Screw in 4 screws with washers at the housing cover diagonally, loosely at first with a Torx driver T20, then tighten.
- ☞ Do **not** tighten until head cover is in contact with housing, maximum torque: 2.2 ft·lb_f (3 Nm).
- Position hose to elbow fitting and screw on the union nut.

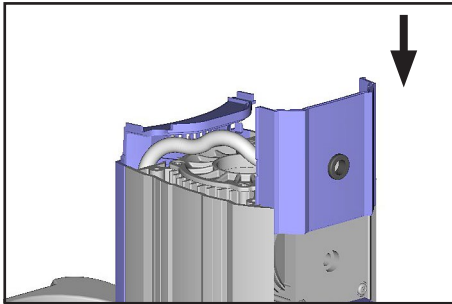

- Position BVC upright.
- Assemble the cover so that the groove in the in the face side of the cover is at the inlet of the pump.

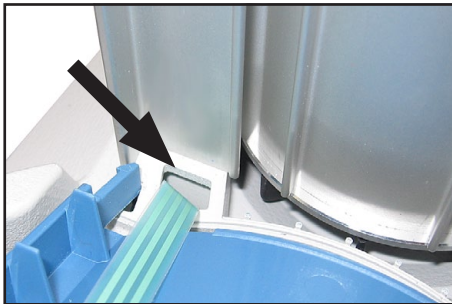

- Only BVC professional / G: In case the cover plate is shifted, ensure that the ribbon cable is not squeezed during reassembly.

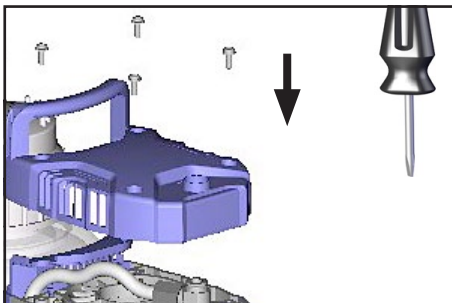

- Screw on cover, paying attention to washers. Maximum torque: 2.2 ft·lb_f (3 Nm).

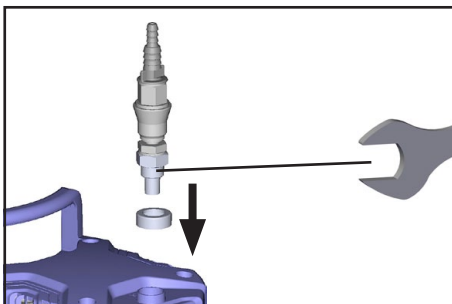

- Screw in hose nozzle or coupling with hose nozzle using an open-ended wrench.

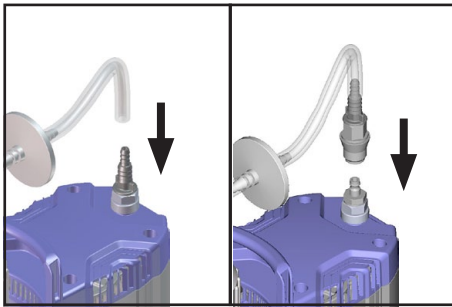

- ➡ Position bottle in the support.
- ➡ Depending on BVC version, position tubing to hose nozzle or quick coupling.

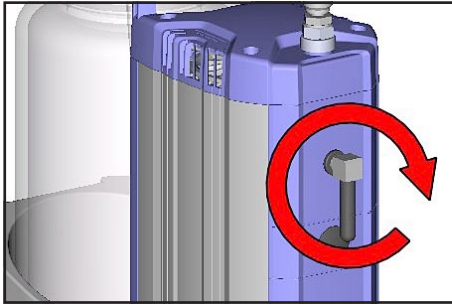

- ➡ Screw elbow fitting with silencer to the outlet of the pump (max. 5 turns).
- ➡ Remove adhesive tape at the cover plate.

Checking the ultimate vacuum

- ➡ After any intervention at the equipment (e.g., repair / maintenance) the ultimate vacuum of the pump has to be checked.
The pump achieves its ultimate vacuum if switching off at an atmospheric pressure > 1000 mbar absolute, a maximum underpressure of 850 mbar (8 LEDs glow) and a leak-free apparatus.

If the pump does not achieve the ultimate vacuum:

- Whenever the diaphragms and valves have been replaced, a break-in period of several hours is required before the pump achieves its ultimate vacuum.
- In case of an unusual noise, switch off pump immediately and check clamping disc positions.

If the specified ultimate vacuum is not achieved, and if this does not change after the break-in period:

If necessary recheck valve seats and pump chamber.

NOTICE

In case of a false alarm of the level sensor after replacing diaphragms and valves perform an adjustment of the level sensor, see section “Adjustment of the BVC level sensor to work properly with a new bottle, or to correct false alarms”.

Replacing the fuse

! DANGER



- ➔ **Switch off the pump.**
- ➔ **Disconnect the electrical power cord** before opening the terminal box. After disconnecting from power, **wait 5 seconds** to allow the capacitors to discharge.
- ☞ Identify and eliminate the cause of failure before switching on the equipment again.

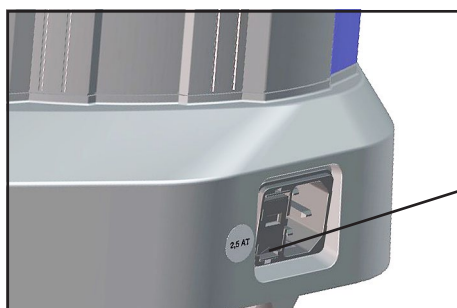

fuse holder



- ➔ Keep the snap-fit squeezed and pull the fuse holder out.
- ➔ The fuse holder contains two fuses of the same type. Replace the defective fuse with a fuse of the same type (see "Technical data")
- ➔ Insert the fuse holder into the housing of the pumping unit until it snaps into place.

Repair - Maintenance - Return - Calibration

IMPORTANT

Every employer (user) is held responsible for the health and safety of his employees. This also applies to service personnel performing repair, maintenance, return or calibration.

The **health and safety clearance form** informs the contractor about any possible contamination of the device and forms the basis for the risk assessment.

In case of devices which have been in contact with biological substances of risk level 2 contact the VACUUBRAND service absolutely before dispatching the device. These devices have to be completely disassembled and decontaminated by the user prior to shipment. Do not return devices which have been in contact biological substances of risk level 3 or 4. These devices cannot be checked, maintained or repaired. Also decontaminated devices must not returned to VACUUBRAND due to a residual risk.

The same conditions apply to on-site work.

No repair, maintenance, return or calibration is possible unless the correctly completed health and safety clearance form is returned. Devices sent are rejected if applicable. Send a completed copy of the **health and safety clearance form** to us in advance. The declaration must arrive before the equipment. Enclose a second completed copy with the product.

Remove all components from the device that are no original VACUUBRAND components. VACUUBRAND will not be responsible for lost or damaged components that are no original components.

Drain the device completely of fluids and residues. Decontaminate the device. Close all openings airtight especially if using substances hazardous to health.

To expedite repair and to reduce costs, please enclose a detailed description of the problem and the product's operating conditions with every product returned.

If you do not wish a repair on the basis of our **quotation**, the device may be returned to you disassembled and at your expense.

In many cases, the components must be cleaned in the factory prior to repair.

For cleaning we use an environmentally friendly water based process. Unfortunately the combined attack of elevated temperature, cleaning agent, ultrasonic treatment and mechanical stress (from pressurised water) may result in damage to the paint. Please mark in the health and safety clearance form if you wish a repaint at your expense just in case such a damage should occur. We will also replace parts for cosmetic reasons at your request and at your expense.

Before returning the device

Pack the device properly, if necessary, please order original packaging materials at your costs.

Mark the package completely

Enclose the completed health and safety clearance form.

Notify the carrier of any possible contamination if required.

Scrapping and waste disposal

Dispose of the equipment and any components removed from it safely in accordance with all local and national safety and environmental requirements. Particular care must be taken with components and waste oil which have been contaminated with dangerous substances from your processes. Do not incinerate fluoroelastomer seals and O-rings. You may authorize us to dispose of the equipment **at your expense**. Otherwise we return the device at your expense.

Health and safety clearance form

1. Device (Model):
2. Serial no.:
3. Reason for return / malfunction:
4. Has the device been used in a copper process step (e.g., semiconductor production): yes no
5. Substances (gases, liquids, solids, biological material, e. g. bacteria, viruses) in contact with the device / which have been pumped:
.....
.....
.....
6. Risk level of the used biological material: none 1 2* 3** 4**
* Contact the VACUUBRAND service absolutely before dispatching the device.
** Devices which have been in contact with biological substances of risk level 3 or 4 cannot be checked, maintained or repaired. Also decontaminated devices must not returned to VACUUBRAND due to a residual risk.
7. Radioactive contamination: yes no
8. Prior to return to the factory the device has been decontaminated: yes no
Description of the decontamination method and the test / verification procedure:
.....
.....
9. All parts of the device are free of hazardous, harmful substances: yes no
10. Protective measures required for service staff:
.....
11. If the paint is damaged, we wish a repaint or a replacement of parts for reason of appearance (repaint and replacement at customer's expense): yes no

12. Legally binding declaration

We assure for the returned device that all substances, which have been in contact with the device are listed in section 5 and that the information is complete and that we have not withheld any information. We declare that all measures - where applicable - have been taken listed in section "Repair - Maintenance - Return - Calibration". By our signature below, we acknowledge that we accept liability for any damage caused by providing incomplete or incorrect information and that we shall indemnify VACUUBRAND from any claims as regards damages from third parties. We are aware that as expressed in § 823 BGB (Public Law Code of Germany) we are directly liable for injuries or damages suffered by third parties, particularly VACUUBRAND employees occupied with handling/repairing the product. Shipping of the device must take place according to regulations.

Name: Signature:

Job title: Company's seal:

Date:

Release for repair grant by VACUUBRAND (date / signature):.....
Protective measures: Protective gloves, safety goggles Hood External cleaning



EG-Konformitätserklärung für Maschinen
EC Declaration of Conformity of the Machinery
Déclaration CE de conformité des machines

Hersteller / Manufacturer / Fabricant:
VACUUBRAND GMBH + CO KG · Alfred-Zippe-Str. 4 · 97877 Wertheim · Germany

Hiermit erklärt der Hersteller, dass das Gerät konform ist mit den Bestimmungen der Richtlinien:
Hereby the manufacturer declares that the device is in conformity with the directives:
Par la présente, le fabricant déclare, que le dispositif est conforme aux directives:

2006/42/EG
2014/30/EU
2011/65/EU

Membranpumpe / Diaphragm pump / Pompe à membrane:
Typ / Type / Type: BVC control, BVC control G, BVC professional, BVC professional G
Artikelnummer / Order number / Numéro d'article: 727200, 727300, 727400, 727500
Seriennummer / Serial number / Numéro de série: Siehe Typenschild / See rating plate / Voir plaque signalétique

Angewandte harmonisierte Normen / Harmonized standards applied / Normes harmonisées utilisées:
DIN EN ISO 12100:2011, DIN EN 61010-1:2011, IEC 61010-1:2010 (Ed. 3),
DIN EN 1012-2:2011, DIN EN 61326-1:2013, DIN EN 50581:2013

Bevollmächtigter für die Zusammenstellung der technischen Unterlagen / Person authorised to compile the technical file / Personne autorisée à constituer le dossier technique:
Dr. J. Dirscherl · VACUUBRAND GMBH + CO KG · Alfred-Zippe-Str. 4 · 97877 Wertheim · Germany

Wertheim, 07.07.2017
.....
ort, Datum / place, date / lieu, date

.....
(Dr. F. Gitmans)
Geschäftsführer / Managing Director /
Gérant

ppa. 
.....
(Dr. J. Dirscherl)
Technischer Leiter / Technical Director /
Directeur technique



VACUUBRAND GMBH + CO KG
Alfred-Zippe-Str. 4 · 97877 Wertheim
T +49 9342 808-0 · F +49 9342 808-5555
info@vacuubrand.com - www.vacuubrand.com



DECLARATION OF CONFORMITY – China RoHS 2

VACUUBRAND GMBH + CO KG has made reasonable efforts to ensure that hazardous materials and substances may not be used in its products.

In order to determine the concentration of hazardous substances in all homogeneous materials of the subassemblies, a "Product Conformity Assessment" (PCA) procedure was performed. As defined in GB/T 26572 the "Maximum Concentration Value" limits (MCV) apply to these restricted substances:

- Lead (Pb): 0.1%
- Mercury (Hg): 0.1%
- Cadmium (Cd): 0.01%
- Hexavalent chromium (Cr(+VI)): 0.1%
- Polybrominated biphenyls (PBB): 0.1%
- Polybrominated diphenyl ether (PBDE): 0.1%

Environmental Protection Use Period (EPUP)



EPUP defines the period in years during which the hazardous substances contained in electrical and electronic products will not leak or mutate under normal operating conditions. During normal use by the user such electrical and electronic products will not result in serious environmental pollution, cause serious bodily injury or damage to the user's assets.

The environmental Protection Use Period for VACUUBRAND products is 40 years.



此表格是按照SJ/T 11363-2006中规定所制定的。

This table is created according to SJ/T 11363-2006.

MATERIAL CONTENT DECLARATION FOR VACUUBRAND PRODUCTS							
部件名称 Part name	有毒有害物质或元素 Hazardous substances						环保期限标识 EPUP
	铅 Pb	汞 Hg	镉 Cd	六价铬 Cr(+VI)	多溴联苯 PBB	多溴二苯醚 PBDE	
包装 Packaging	○	○	○	○	○	○	
塑料外壳 / 组件 Plastic housing / parts	○	○	○	○	○	○	
真空油 Vacuum oil	○	○	○	○	○	○	
电池 Battery	○	○	○	○	○	○	
玻璃 Glass	○	○	○	○	○	○	
电子电气组件 Electrical and electronic parts	X	X	X	○	○	○	
控制器 / 测量设备 Controller / measuring device	X	○	X	○	○	○	
金属外壳 / 组件 Metal housing / parts	X	○	○	○	○	○	
电机 Motor	X	○	○	○	○	○	
配件 Accessories	X	○	○	○	○	○	



vacuubrand

注释: 此表格适用于所有产品。以上列出的元件或组件不一定都属于所附产品的组成。

Note: Table applies to all products. Some of the components or parts listed above may not be part of the enclosed product.

- O: 表示该有毒有害物质在该部件所有均质材料中的含量均在GB/T 26572规定的限量要求以下。
O: Indicates that the above mentioned hazardous substance contained in all homogeneous materials of the part is below the required limit as defined in GB/T 26572.
- X: 表示该有毒有害物质至少在该部件某一均质材料中的含量超出GB/T 26572规定的限量要求。
X: Indicates that the above mentioned hazardous substance contained in at least one of the homogeneous materials of this part is above the required limit as defined in GB/T 26572.

除上表所示信息外，还需声明的是，这些部件并非是有用铅（Pb）、汞（Hg）、铬（Cd）、六价铬（Cr(+VI)）、多溴联苯（PBB）或多溴二苯醚（PBDE）来制造的。

Apart from the disclosures in the above table, the subassemblies are not intentionally manufactured or formulated with lead (Pb), mercury (Hg), cadmium (Cd), hexavalent chromium (Cr+VI), polybrominated biphenyls (PBB), and polybrominated diphenyl ethers (PBDE).

Products manufactured by VACUUBRAND may enter into further devices (e.g., rotary evaporator) or can be used together with other appliances (e.g., usage as booster pumps).

With these products and appliances in particular, please note the EFUP labeled on these products. VACUUBRAND will not take responsibility for the EFUP of those products and appliances.

Place, date: Wertheim, 04/24/2017



(Dr. F. Gitmans)
Managing Director



ppa. (Dr. J. Dirscherl)
Technical Director

VACUUBRAND GMBH + CO KG

Alfred-Zippe-Str. 4
97877 Wertheim
Germany

Tel.: +49 9342 808-0

Fax: +49 9342 808-5555

E-Mail: info@vacuubrand.com

Web: www.vacuubrand.com

Disclaimer: Our technical literature is only intended to inform our customer. The applicability of general empirical values and results obtained under lab conditions to your specific operations depends on a number of factors beyond our control. It is, therefore, strictly the users' responsibility to very carefully check the application of these data to their specific requirements. No claims arising from the information provided in this literature will, consequently, be entertained.



Alfred-Zippe-Str. 4 · 97877 Wertheim / Germany
T +49 9342 808-0 · F +49 9342 808-5555
info@vacuubrand.com · www.vacuubrand.com

VACUUBRAND GMBH + CO KG
- Technology for Vacuum Systems -
© 2017 VACUUBRAND GMBH + CO KG Printed in Germany

Manual-no.: 999263 / 07/07/2017