

# Turbopack - Turbostand

## SYSTEME DE POMPAGE TURBOMOLECULAIRE

## TURBOMOLECULAR PUMPING SYSTEM



-Réalisation/Publication: Alcatel Vacuum Technology France - Manuel de l'utilisateur - Ed 07 - Date : 06/2008 - Référence : 105988



## Manuel de l'utilisateur

## User's Manual

**adixen**

by Alcatel Vacuum Technology

# **TURBOPACK / TURBOSTAND**

Turbomolecular Pumping System

User's Manual



By Alcatel Vacuum Technology



Alcatel Vacuum Technology, as part of the Alcatel-Lucent Group, has been supplying vacuum pumps, helium and hydrogen leak detection systems, plasma sensors, vacuum measurement for several years.

Thanks to its complete range of products, the company has become an essential player in multiple applications : instrumentation, Research & Development, industry and semiconductors.

Alcatel Vacuum Technology has launched Adixen, its new brand name, in recognition of the company's international standing in vacuum position.

With both ISO 9001 and 14001 certifications, the French company is an acknowledged expert in service and support, and Adixen products have the highest quality and environmental standards.



With 45 years of experience, AVT today has a worldwide presence, through its international network that includes a whole host of experienced subsidiaries, distributors and agents.

The first step was the founding of Alcatel Vacuum Products (Hingham- MA) in the United States, thirty years ago, reinforced today by 2 others US subsidiaries in Fremont (CA) and Tempe (AZ).

In Europe, AVTF-France headquarters and its subsidiaries, Alcatel Hochvakuumtechnik (Germany), Alcatel Vacuum Technology UK (Scotland), Alcatel Vacuum Technology Benelux (Netherlands), Alcatel Vacuum Systems (Italy) and more recently Adixen Sensistor AB in Sweden (in 2007) form the foundation for the European partner network.

In Asia, our presence started in 1993 with Alcatel Vacuum Technology (Japan), and has been strengthened with Alcatel Vacuum Technology Korea (in 1995), Alcatel Vacuum Technology Taiwan (in 2001), Alcatel Vacuum Technology Singapore, Alcatel Vacuum Technology Shanghai (China) (in 2004).

This organization is rounded off by more than 40 representatives based in a variety of continents.

Thus, whatever the circumstances, the users of Adixen products can always rely on quick support of our specialists in Vacuum Technology.



---

# Pumping system TURBOPACK TURBOSTAND

## Welcome

Dear Customer,

You have just purchased an Adixen pumping system. We would like to thank you and are proud to count you as one of our customers.

This product has benefited from Alcatel Vacuum Technology's many years of experience in the field of pumping system design.

**In order to ensure the best possible performance of the equipment and your complete satisfaction in using it, we advise you to read this manual carefully before any intervention on your pump and to pay particular attention to the equipment installation and start-up section.**



## APPLICATIONS:

- Public Research and Development:
  - universities, schools,
  - public laboratories,
  - particle accelerators, nuclear power.
- Private research and Development:
  - laboratories for the private enterprises (Thin films, instrumentation, electronic, chemistry...).
- Industry:
  - space / aerospace ...simulation,
  - thin film deposition,
  - ion pump evacuation,
  - UHV system,
  - particle accelerators, instrumentation
  - ion source,
  - surface analysis,
  - mass spectrometer,
  - optical systems.

---

## **Pumping system TURBOPACK / TURBOSTAND**

**This product complies with the requirements of European Directives, listed in the Declaration of Conformity contained in G 100 of this Manual.  
These Directives are amended by Directive 93/68/E.E.C (E.C Marking).**

**Copyright/Intellectual property:**

**The use of Adixen products are subject to copyright and intellectual property rights in force in any jurisdiction.**

**All rights reserved, including copying this document in whole or any part without prior written authorization from Alcatel Vacuum Technology France.**

**Specifications and information are subject to change without notice by Alcatel Vacuum Technology France.**

# Contents

## TURBOPACK - TURBOSTAND

### User's Manual

<b>Chapter A</b>	<b>PRESENTATION</b>
A 10 - Presentation A 20 - The different versions of the pumping systems A 30 - Different options A 40 - Pumping system operating principle A 50 - Technical characteristics A 60 - Accessories	
<b>Chapter B</b>	<b>STARTING-UP</b>
B 00 - Safety instructions B 10 - Positioning the pumping system in the installation B 20 - Pumping system connection to an installation B 30 - Accessories connection B 40 - Rotary vane pump oil filling B 50 - Pumping system electrical connection B 60 - ACT 200 T / ACT 600 TH controller starting-up	
<b>Chapter C</b>	<b>UTILIZATION</b>
C 00 - Safety instructions C 10 - Pumping system utilization	
<b>Chapter D</b>	<b>MAINTENANCE</b>
D 00 - Safety instruction related to maintenance D 10 - Remedies and troubleshootings	
<b>Chapter E</b>	<b>MAINTENANCE DIAGNOSIS</b>
E 10 - Maintenance	
<b>Chapter F</b>	<b>MAINTENANCE COMPONENTS</b>
F 10 - Electrical box schematic diagram F 20 - Maintenance parts F 000 - Spare parts - Instructions of use	
<b>Chapter G</b>	<b>APPENDIX</b>
G 100 - Conformity of declaration G 200 - Safety instructions	

---

## TURBOPACK - TURBOSTAND User's Manual

### **CAUTION**

Indicates a potentially hazardous situation which, if not avoided, could result in property damage.

### **⚠ CAUTION**

Indicates a potentially hazardous situation which, if not avoided, could result in moderate or minor injury. It may also be used to alert against unsafe practices.

### **⚠ WARNING**

Indicates a potentially hazardous situation which, if not avoided, could result in death or severe injury.

### **⚠ DANGER**

Indicates an imminently hazardous situation that, if not avoided, will result in death or severe injury (extreme situations).

## Presentation

**Presentation** Turbopack and Turbostand pumping system include a turbo molecular pump ATP serie, and a roughing pump. Either RVP Pascal serie or ACP serie.

There are 2 available main configurations

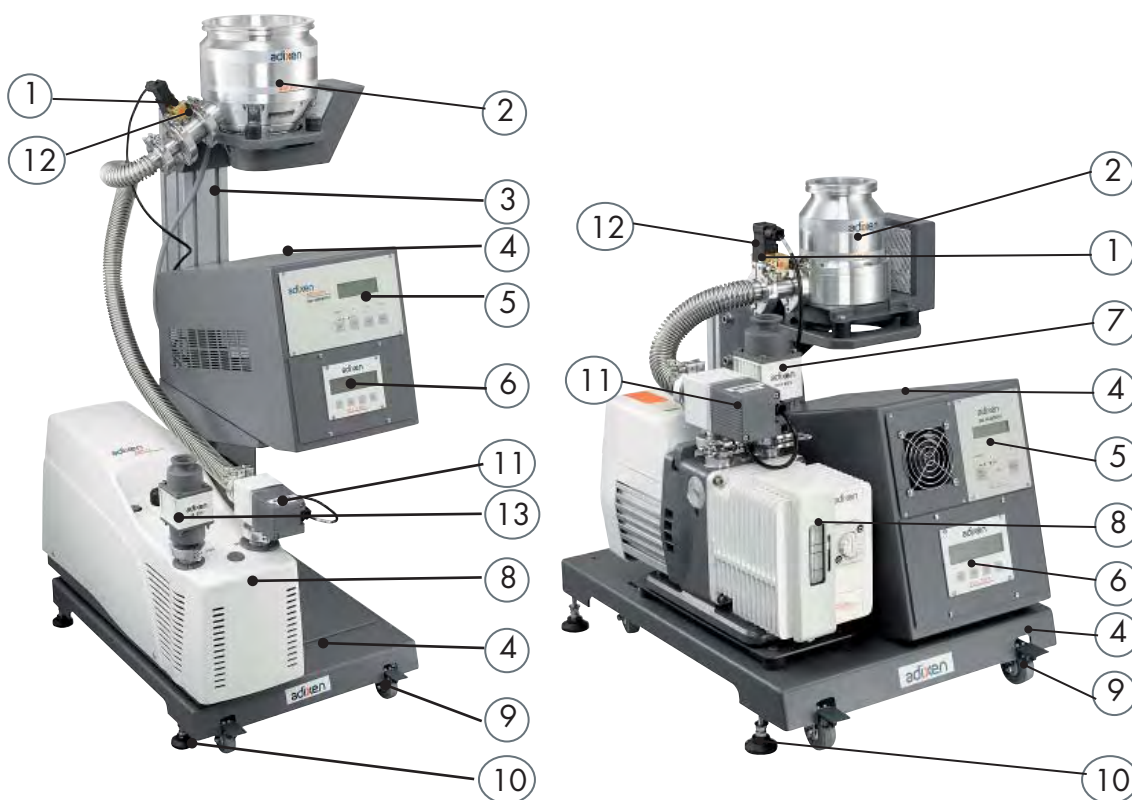

• TURBOSTAND: Tall version

• TURBOPACK: Short version

- |                                    |                                 |
|------------------------------------|---------------------------------|
| 1 Plastic cover                    | 8 Roughing pump (RVP or ACP)    |
| 2 Turbomolecular pump (ATP)        | 9 Casters (option on Turbopack) |
| 3 Column                           | 10 Screw jacks                  |
| 4 Frame                            | 11 Isolation valve              |
| 5 Controller (ACT)                 | 12 Turbo vent valve             |
| 6 Vacuum gauge controller (option) | 13 ACP silencer                 |
| 7 Oil mist eliminator              |                                 |



## The different versions of the pumping systems

The manufacturer provides different versions to adapt the pumping system to the customer applications.

### The different versions available

Turbopack or Turbostand components

	Standard version				Chemical version **			
<b>Turbomolecular pumps</b>	ATP 80	ATP 100	ATP 150	ATP 400	ATP 80C	ATP 100C	ATP 150C	ATP 400C
<b>Inlet flanges ISO - KF or CF - F</b>	DN 63	DN 100		DN 100 DN 160	DN 63	DN 100		DN 100 DN 160
<b>Cooling (ATP)</b>	Air or water				Air or water			
<b>Controllers</b>	ACT 200 T		ACT 600 TH		ACT 200 T		ACT 600 TH	
<b>Rotary vane pumps *</b>	2005/2010		2015/2021		2005C/2010C		2015C/2021C	
<b>Oil mist eliminator</b>	OME 25 S				OME 25 C			
<b>Dry roughing pump *</b>	ACP 15 - ACP 28 - ACP 40				ACP 28G - ACP 40G			
<b>Silencer</b>	ES 25 S							

\* Either rotary vane pump type RVP with oil mist eliminator, or dry roughing pump type ACP and ES 25 S.

\*\* The chemical pump versions are available only by custom request.

Additionally, it is possible to customize the product with options.  
See sheet  **A 30**

### Items delivered

- Pumping system (see table above)
  - Oil mist eliminator ( not installed) RVP only.
  - Electrical cables (interconnecting and power)
  - Hoisting ring
  - Inlet screen
  - Copper ring for CF-F flange
  - 2 or 6 claw clamps for ISO-KF flange (depending on the model)
  - Oil for rotary vane pump (RVP)
  - Turbomolecular pump, RVP or ACP and controller user's manual
  - Silencer (ACP only)
  - Turbo venting valve
  - Gauge, controller, cable
  - ISV 25 (security valve)
- See sheet  **F 20**

## Different options

The options offered in the pumping system template are factory installed.

Options available:

<b>Turbomolecular pump</b>	<b>ATP 80/100/150</b>	<b>ATP 80C/100C/150C</b>	<b>ATP 400</b>	<b>ATP 400C</b>
ATP vent valve	DN 25 + cable + coil 24 V		DN 40 + cable + coil 24 V	
Isolation safety valve	ISV 25 with cable	*	ISV 25 with cable	*

## Gauge and controller

<b>Controller</b>	ACS 2000 Controller with 1 channel ACM 2000 Controller with 3 channels
<b>Head gauge</b>	Pirani AP 2004 Pirani / Penning ACC 2009 Crystal Bayart Alpert AHC 2010

These components are also available as accessories in the Adixen catalog and can be easily installed at your location.

See sheet  **A 60**

## Pumping system operating principle

### Function of the pumping system components

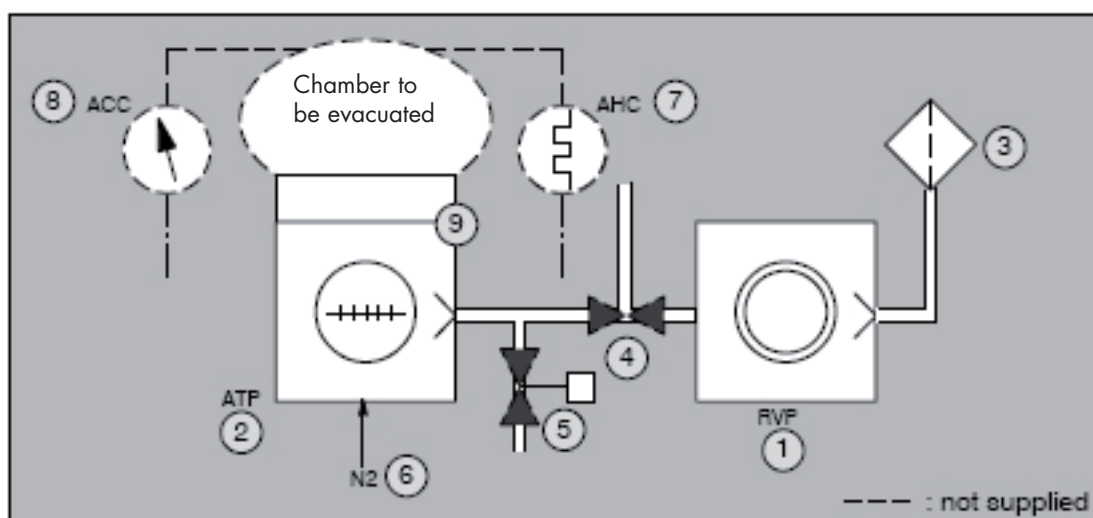

DESCRIPTION	ITEM	FUNCTION
Roughing pump (RVP or ACP)	1	Carries out pumping from a chamber, through the turbomolecular pump from atmospheric pressure to roughing pump ultimate pressure.
ATP Turbomolecular pump and inlet screen	2 9	Carries out high vacuum pumping up to turbomolecular pump ultimate pressure. See sheet  A 50 . It is equipped with inlet screen which protects the pump against solid particles.
Oil mist eliminator	3	At the exhaust of the rotary vane pump, this separates oil droplets and vapors in the exhaust gases emitted by the oil-sealed vacuum pumps.
Rotary vane pump isolation valve	4	In the event of the stop of RVP pump, it isolates the roughing pump from the turbomolecular pump and ensures roughing pump venting.
ATP Vent valve (option)	5	It allows atmospheric pressure resetting after stopping or when a power failure occurs.
N2 purge (if corrosive version turbomolecular pump)	6	It allows dry gas introduction (nitrogen) into the pump when corrosive gases are pumped to protect ball bearings of the turbomolecular pump.
Vacuum gauge (option)	7 - 8	It allows high pressure range measurement or low pressure range measurement.

## Technical characteristics

### Technical characteristics

	Unit		ATP 80		ATP 100		ATP 150		ATP 400	
Secondary pumping speed N <sub>2</sub> H <sub>E</sub> H <sub>2</sub>	l/s		80		100		140		400	
			50		60		100		300	
			40		40		80		250	
Limit pressure (1) without purge N <sub>2</sub> according to Pneurop standard	mbar	RVP	5.10 <sup>-9</sup>		5.10 <sup>-9</sup>		5.10 <sup>-10</sup>		8.10 <sup>-10</sup>	
		ACP 15	1.10 <sup>-7</sup>		7.10 <sup>-8</sup>		7.10 <sup>-8</sup>		7.10 <sup>-8</sup>	
		ACP 28								
		ACP 40								
Limit pressure (2) without purge N <sub>2</sub> according to Pneurop standard	mbar	RVP	5.10 <sup>-8</sup>				1.10 <sup>-7</sup>			
Primary pumping speed (3)	m <sup>3</sup> /h	PPM	5 to 21						15 to 21	
		ACP 15	14							
		ACP 28	27							
		ACP 40	37							
Maximum pressure in continuous operation at inlet	mbar	(1)	1.10 <sup>-1</sup>		1.10 <sup>-1</sup>		1.10 <sup>-1</sup>		2.10 <sup>-2</sup>	
		(2)								
Start-up time			1 mn 45 s				2 mn		3 mn	
Cooling			air	water	air	water	air	water	air	water
Mini / max ambient temperature (4)	°C		15 / 35	15 / 50	15 / 35	15 / 50	15 / 35	15 / 50	15 / 35	15 / 50
Inlet flange ISO-K ou CF-F			DN 63		DN 100				DN 100 ou DN 160	
Maximum power	KW		0.8		0.8		1		1	
Oil capacity	L	RVP	2005 = 0.83 / 2010/2015 = 0.95 / 2021 = 0.98							
		ACP	For the ACP dry roughing pump, the oil has been introduced in the pump at factory. Don't readjust the oil level.							
Maximum weight on support flange	Kg / Lbs		50 kg / 110 Lbs							

(1) For the standard pumping systems equipped with CF-F flange

(2) For the corrosive pumping systems equipped with CF-F flange

(3) Depends on the configuration

(4) With water cooling, the ambient temperature around the turbomolecular pump can reach 50 °C

### CAUTION

The ACP roughing pump can not be used in chemical version pumping group.

## Technical characteristics

### Weights

#### Turbopack

Primary pump	Secondary pump			
	ATP 80	ATP 100	ATP 150	ATP 400
RVP 2005	121 lbs/55 kg	121 lbs/55 kg	130 lbs/59kg	-
RVP 2010	123 lbs/56kg	123 lbs/56kg	132 lbs/60kg	-
RVP 2015	125 lbs/57kg	125 lbs/57kg	134 lbs/61kg	141 lbs/64kg
RVP 2021	127 lbs/58kg	127 lbs/58kg	136 lbs/62kg	143 lbs/65kg
ACP 15	132 lbs/60kg	132 lbs/60kg	141 lbs/61kg	147 lbs/67kg
ACP 28	154 lbs/70kg	154 lbs/70kg	163 lbs/74kg	169 lbs/77kg
ACP 40	169 lbs/77kg	169 lbs/77kg	178 lbs/81kg	185 lbs/84kg

#### Turbostand

Primary pump	Secondary pump			
	ATP 80	ATP 100	ATP 150	ATP 400
RVP 2005	132 lbs/60kg	132 lbs/60kg	141 lbs/64kg	-
RVP 2010	134 lbs/61kg	134 lbs/61kg	143 lbs/65kg	-
RVP 2015	136 lbs/62kg	136 lbs/62kg	145 lbs/66kg	152 lbs/69kg
RVP 2021	138 lbs/63kg	138 lbs/63kg	147 lbs/67kg	154 lbs/70kg
ACP 15	143 lbs/65kg	143 lbs/65kg	152 lbs/69kg	154 lbs/70kg
ACP 28	165 lbs/75kg	165 lbs/75kg	174 lbs/79kg	176 lbs/80kg
ACP 40	180 lbs/82kg	180 lbs/82kg	189 lbs/86kg	191 lbs/87kg

## Technical characteristics

### TURBOPACK dimensions (with RVP)

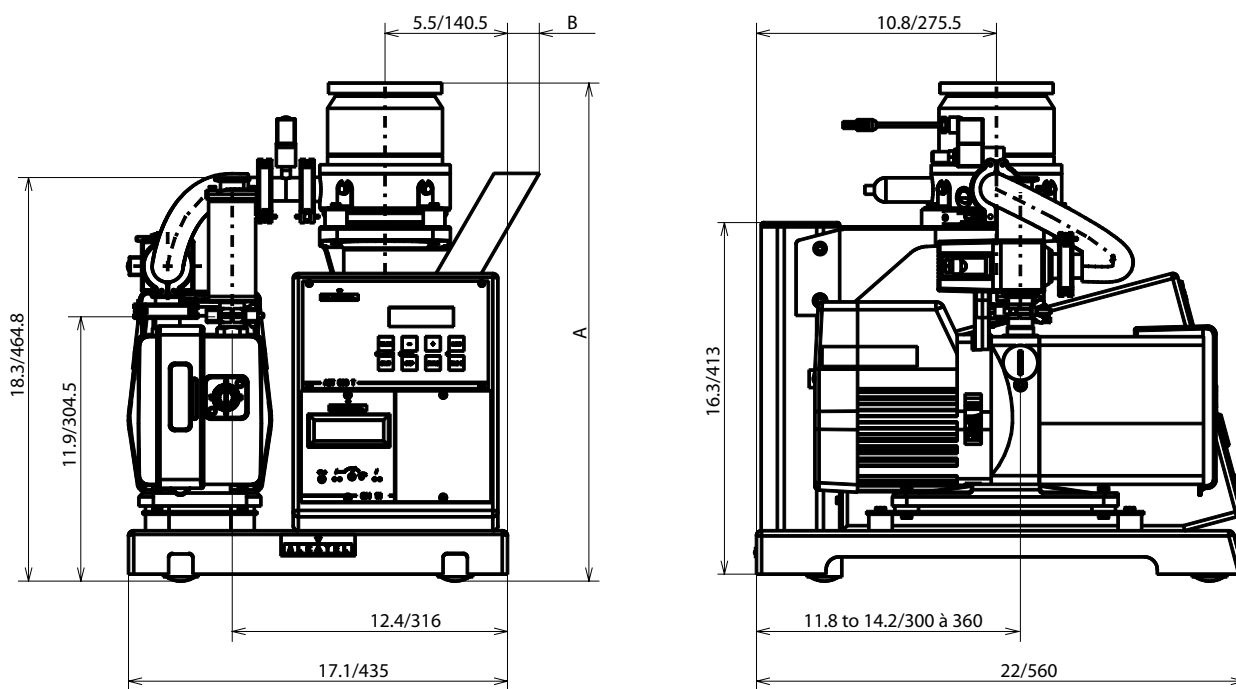

Inch/mm

Turbomolecular pump types	A* (inch-mm)	B (inch-mm)
ATP 80 DN 63 ISO-KF	24 / 597	-
ATP 80 DN 63 CF-F	28 / 720	-
ATP 100 D 100 ISO-KF	22 / 566	-
ATP 100 DN 100 CF-F	23 / 586	-
ATP 150 DN 100 ISO-KF	23 / 578	1
ATP 150 DN 100 CF-F	23 / 585	1
ATP 400 DN 100 ISO-KF	25 / 622	1
ATP 400 DN 100 CF-F	24 / 616	1
ATP 400 DN 160 ISO-KF	23 / 591	1
ATP 400 DN 160 CF-F	24 / 608	1
With casters (option)	+ 1 / +34	-

\* Maximum height

## Technical characteristics

### TURBOSTAND dimensions (with RVP)

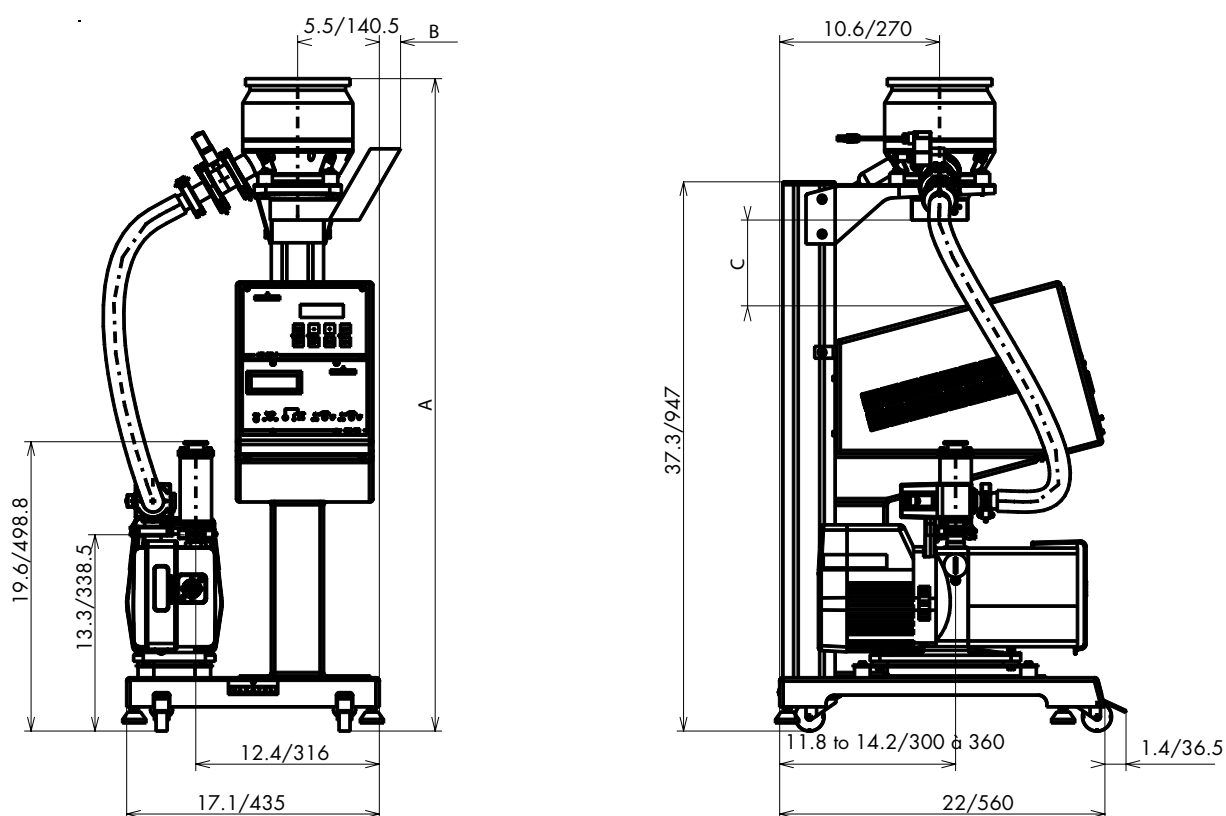

Inch/mm

Turbomolecular pump types	A* (inch-mm)	B (inch-mm)
ATP 80 DN 63 ISO-KF	44 / 1127	*
ATP 80 DN 63 CF-F	45 / 1142	*
ATP 100 DN 100 ISO-KF	43 / 1100	*
ATP 100 DN 100 CF-F	44 / 1120	*
ATP 150 DN 100 ISO-KF	44 / 1108	1 / 35
ATP 150 DN 100 CF-F	44 / 1119	1 / 35
ATP 400 DN 100 ISO-KF	46 / 1156	1 / 35
ATP 400 DN 100 CF-F	46 / 1157	1 / 35
ATP 400 DN 160 ISO-KF	44 / 1125	1 / 35
ATP 400 DN 160 CF-F	45 / 1142	1 / 35

\* Maximum height

## Technical characteristics

### TURBOPACK dimensions with ACP 28/ACP 40

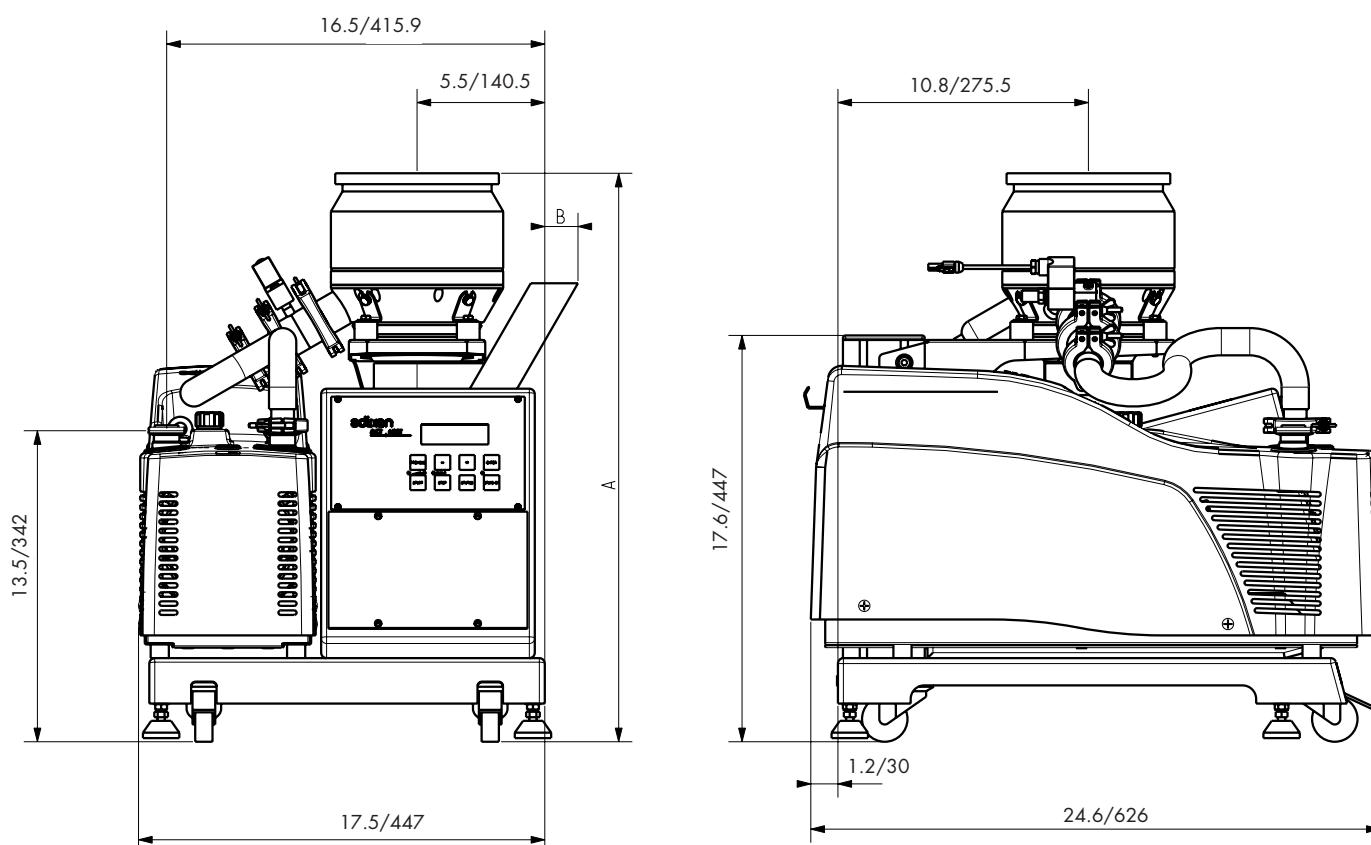

Inch/mm

Turbomolecular pump types	A* (inch-mm)	B (inch-mm)
ATP 80 DN 63 ISO-KF	25 / 627	-
ATP 80 DN 63 CF-F	30 / 754	-
ATP 100 DN 100 ISO-KF	24 / 600	-
ATP 100 DN 100 CF-F	24 / 620	-
ATP 150 DN 100 ISO-KF	24 / 608	1 / 35
ATP 150 DN 100 CF-F	24 / 619	1 / 35
ATP 400 DN 100 ISO-KF	26 / 656	1 / 35
ATP 400 DN 100 CF-F	26 / 657	1 / 35
ATP 400 DN 160 ISO-KF	25 / 625	1 / 35
ATP 400 DN 160 CF-F	25 / 642	1 / 35
Without casters	-1 / - 34	-

\* Maximum height



## Technical characteristics

### TURBOSTAND dimensions with ACP 28/ACP 40

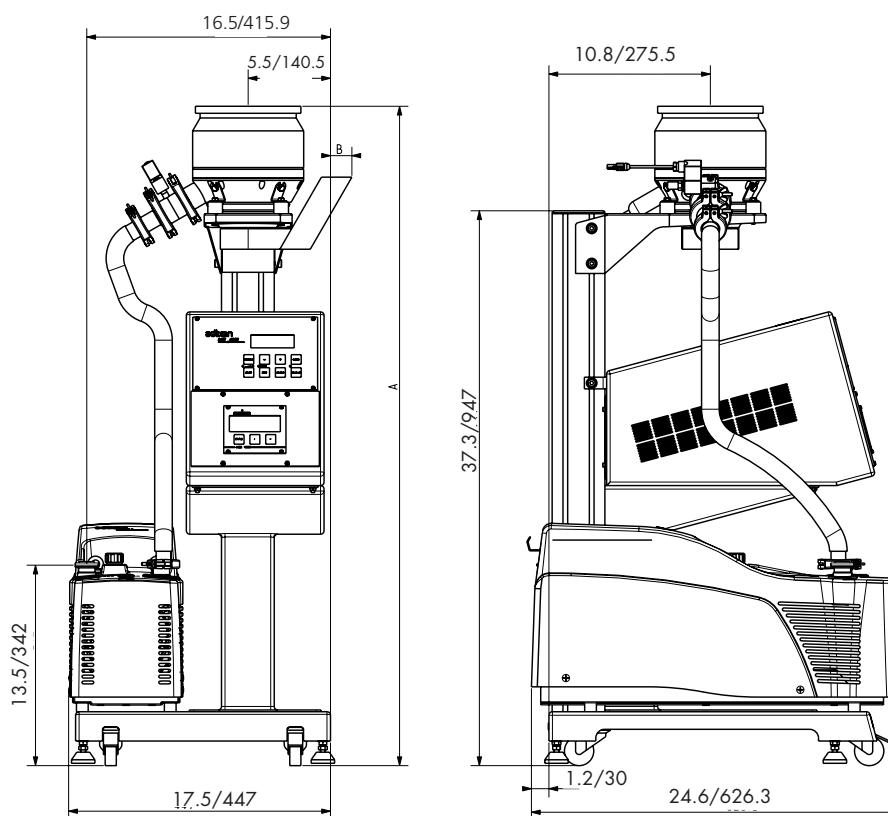

Inch/mm

Turbomolecular pump types	A* (inch-mm)	B (inch-mm)
ATP 80 DN 63 ISO-KF	44 / 1127	-
ATP 80 DN 63 CF-F	49 / 1142	-
ATP 100 DN 100 ISO-KF	43 / 1100	-
ATP 100 DN 100 CF-F	44 / 1120	-
ATP 150 DN 100 ISO-KF	44 / 1108	1 / 35
ATP 150 DN 100 CF-F	44 / 1119	1 / 35
ATP 400 DN 100 ISO-KF	46 / 1156	1 / 35
ATP 400 DN 100 CF-F	46 / 1157	1 / 35
ATP 400 DN 160 ISO-KF	44 / 1125	1 / 35
ATP 400 DN 160 CF-F	45 / 1142	1 / 35

\* Maximum height

## Technical characteristics

### TURBOPACK dimensions with ACP 15

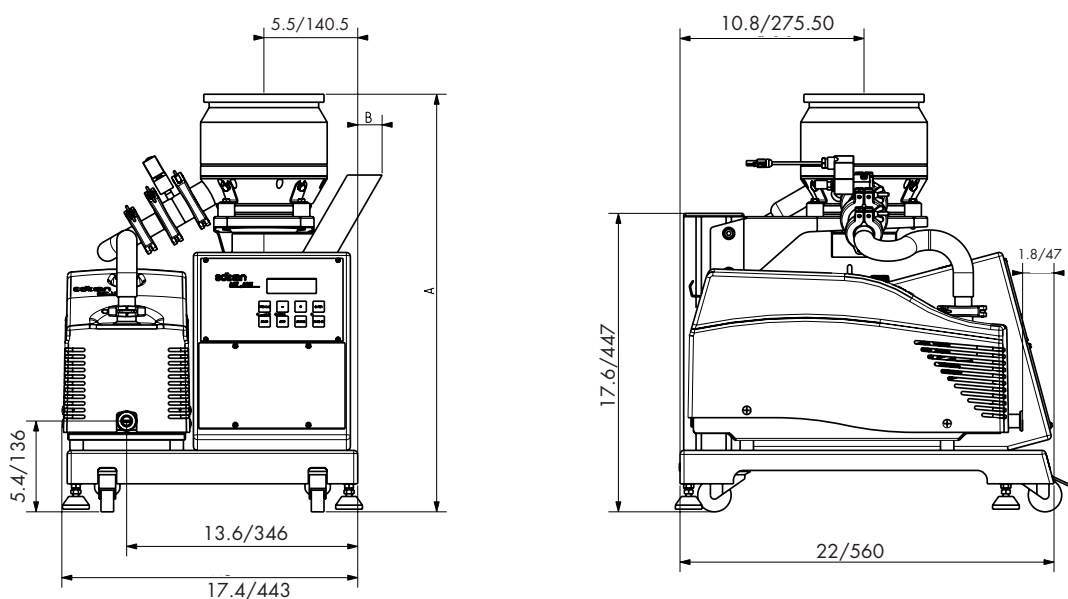

Inch/mm

Turbomolecular pump types	A* (inch-mm)	B (inch-mm)
ATP 80 DN 63 ISO-KF	25 / 627	-
ATP 80 DN 63 CF-F	30 / 754	-
ATP 100 DN 100 ISO-KF	24 / 600	-
ATP 100 DN 100 CF-F	24 / 620	-
ATP 150 DN 100 ISO-KF	24 / 608	1 / 35
ATP 150 DN 100 CF-F	24 / 619	1 / 35
ATP 400 DN 100 ISO-KF	26 / 656	1 / 35
ATP 400 DN 100 CF-F	26 / 657	1 / 35
ATP 400 DN 160 ISO-KF	25 / 625	1 / 35
ATP 400 DN 160 CF-F	25 / 642	1 / 35
Without casters	- 1 / -34	-

\* Maximum height

## Technical characteristics

### TURBOSTAND dimensions with ACP 15

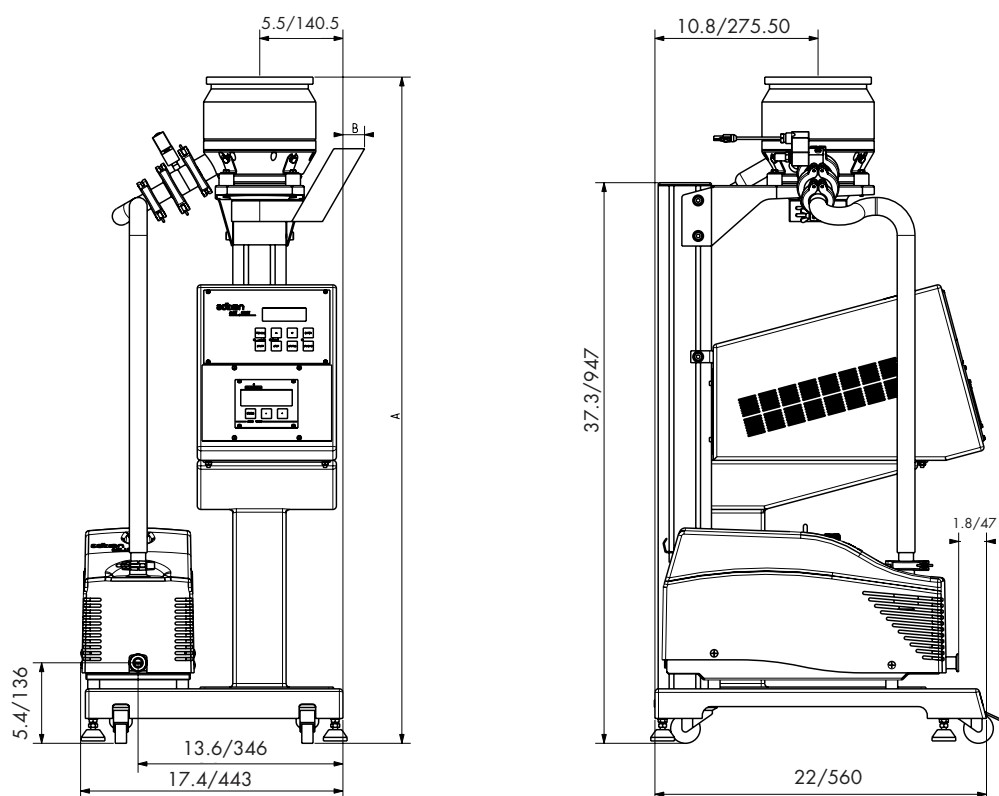

Turbomolecular pump types	A* (inch-mm)	B (inch-mm)
ATP 80 DN 63 ISO-KF	44 / 1127	-
ATP 80 DN 63 CF-F	49 / 1254	-
ATP 100 DN 100 ISO-KF	43 / 1100	-
ATP 100 DN 100 CF-F	44 / 1120	-
ATP 150 DN 100 ISO-KF	44 / 1108	1 / 35
ATP 150 DN 100 CF-F	44 / 1119	1 / 35
ATP 400 DN 100 ISO-KF	46 / 1156	1 / 35
ATP 400 DN 100 CF-F	46 / 1157	1 / 35
ATP 400 DN 160 ISO-KF	44 / 1125	1 / 35
ATP 400 DN 160 CF-F	45 / 1142	1 / 35

\* Maximum height

## Accessories

### ATP Accessory Part Numbers

Inlet screens P/N (1)	P/N				
	ATP 80 ATP 80 C	ATP 100 ATP 100 C	ATP 150 ATP 150 C	ATP 400 ATP 400 C with flange DN 100	ATP 400 ATP 400 C with flange DN 160
ISO-K	063000	056844	056844	056844	056942
CF-F	063115	056845	056845	056845	056928

Claw clamps P/N*	P/N	
	ATP 80 / 100 / 150 ATP 80 C / 100 C / 150 C	ATP 400 ATP 400 C
DN 63 /100 ISO-KF	303056	-
DN 160 / 250 ISO-KF	-	303057

Vent valve	P/N	
	ATP 80 / 100 / 150 ATP 80 C / 100 C / 150 C	ATP 400 ATP 400 C
DN 25	108348	-
DN 40	-	108349
Coil 24 VDC	038066	038066

### RVP / ACP Accessories Part Numbers

Oil mist eliminator (1)	P/N	
	PPM 2005 / 2010 /2015 / 2021 SD et I	RVP 2005 C / 2010 C / 2015 C / 2021 C
OME 25 S	104200	-
OME 25 C	-	066849
Isolation valve (2)		066867
ISV 25 valve cable (2)		105489
ACP silencer		109873

(1) Included in the standard configuration.

**CAUTION**

(2) The isolation valve ISV 25 do never be used in pumping group chimist.

---

## Accessories

### Vacuum gauge accessory Part Numbers

Vacuum gauge		P/N
AP 2004	Pirani gauge DN 16 ISO-KF	112646
AP 2004	Pirani Gauge DN 16 CF-F	112647
ACC 2009	Cold cathode Pirani gauge DN 25 ISO-KF	112655
ACC 2009	Cold cathode Pirani gauge DN 40 CF-F	112657
AHC 2010	Crystal gauge DN 25 ISO-KF	112661
AHC 2010	Crystal gauge DN 40 CF-F	112663
Gauge cable (5 meters) included in standard group		112752
Gauge cable (10 meters)		112753
Gauge cable (20 meters)		112754

Controller		P/N
ACS 2000	ACS controller single channel	112711
1/2 rack measure adaptor ACS 2000		A329364
ACM 2000	ACM 2000 controller 3 channels	112712
1/2 rack measure adaptor ACM 2000		A331237
Internal main cable for controller		105255

## Safety instructions

Before powering up, the user must study the manual and follow the safety instructions.

### Decontamination – product dismantling

According to the regulations 2002/96/CE about Waste of electrical and electronical equipments, and 2002/95/CE about Restriction of Hazardous substances, the manufacturer provides a recycling paid service for the end-of-life of waste electrical and electronic equipment.

Any obligation of the manufacturer to take back such equipment shall apply only to complete not amended or modified equipment, using Alcatel Vacuum Technology original spare parts, delivered by Alcatel Vacuum Technology, containing i.e. all its components and sub-assemblies.

This obligation will not cover the shipping cost to an Alcatel Vacuum Technology take back facility.

Before returning the product, fill in the safety form, attach it to the product before shipping to the service-repair office closest to you.

### Unpacking

- Do not discard the packaging until you have ensured that the pumping system has not been damaged during transport. Otherwise, take the necessary measures with the transporting company and, if necessary, notify the manufacturer. It is advisable to keep the packaging for the redispaching.

- **The rotary vane pump RVP Type** is not supplied filled with oil. The oil is contained in separate bottles. Similarly, it is recommended to drain the pump before redispaching the equipment.

### ATP turbomolecular pump storage

- **The turbomolecular pump ATP** can be stored without special precautions (ambient temperature between 5 and 40 °C) **provided that the running - in procedure specified in the manual  C 10 is observed for the first operation of the pump.**

---

## Safety instructions

### Rotary vane pump storage

- If the rotary vane pump is to be stored, we guarantee the reliability of our equipment without particular storage precautions for up to 3 months (ambient temperature between 41 °F and 149 °F or 5 and 65 °C).
- For storage periods of over 3 months, we recommended to fill the pump with oil during storage. For this, fill the pump with the charge of oil and run it at ultimate vacuum (inlet orifice blocked) for approximately 1 hour in order to lubricate all the parts of the functional block. Then, stop the pump and store it with the inlet and exhaust orifices sealed : clamping ring, centring ring, plug, etc. The shaft can be rotated by hand or by starting the pump every six months following this storage procedure.
- After 6 months storage without oil, factors such as temperature, degree of humidity, salt air, etc. may cause the deterioration of the pump components, particularly the hardening of O-rings and the "sticking" of lip seals on shafts and the gumming of oil. In this state, a pump may have operational problems, particularly oil leaks. Before any start-up (new pump as well as used), the primary pump must be disassembled (see User's Manual), and all the seals changed.
- The seal kits must be stored away from heat and light (direct sunlight and ultraviolet radiation) in order to prevent any hardening of the elastomers.

### ACP storage

If the new pump is to be stored, the plugs on the inlet and exhaust ports must remain in position. The storage temperature must not be below -50 F° or -10 °C.

---

## Safety instructions

**CAUTION**

The pumping units must be connected to an electrical installation in compliance with decree 88 - 1056 of 14th November 1988.

**CAUTION**

Our products are designed to comply with current EEC regulations. Any modification of the product is liable to result in non-compliance with regulations, or affect the EMC (Electromagnetic compatibility) performances and safety of the product. The manufacturer declines responsibility for consequences resulting from such an intervention.

**⚠ WARNING**

It is important to isolate the pumping system from the power source before any intervention on the equipment (for maintenance purpose).

**⚠ CAUTION**

The units containing control circuits are designed to guarantee normal safety conditions taking their normal operating environment into account. In specific cases of use on tables, make sure that no objects enter the ventilation openings or block the openings when handling the units.

**⚠ CAUTION**

Some controllers can be configured to start up automatically after a power cut. In this case, it is the user's responsibility to take all the precautions required to prevent the risks resulting from this type of operation.



## Safety instructions

### CAUTION

The performances and operating safety of this product can only be guaranteed if it is used in compliance with its normal use.

### CAUTION

Before any maintenance operation on a product performed by a maintenance operator not qualified on safety regulations (EMC, electrical safety, chemical pollution, etc.), shut off the product from its different power sources (electricity, compressed air, etc.).

### CAUTION

Products' EMC performances are subject to the installation being carried out in compliance with the applicable EMC regulations. Particularly in environments subject to interference, it is essential to:

- use shielded links and connections for interfaces,
- stabilise the power supply line with a mesh from the power supply source up to a distance to 3 m with respect to the product input.

### DANGER

When powering up an item of equipment containing capacitors loaded at over 60 VDC or 25 VAC, precautions must be taken at the connector pin access.  
Electrical shocks may cause severe injuries.  
Before working on the pumping unit, it is recommended to wait 1 minute after setting the main switch to 0.

### CAUTION

Do not move or induce a shock on a pump in operation. This could result in a risk of crash.

### WARNING

It is dangerous to access the rotor of a turbomolecular pump on which the intake is not connected.  
Even if the pump is not powered, it may be driven by another pump in operation.  
Severe cuts may be caused on contact.  
Before working on the pumping unit, it is recommended to:

- stop the pumping unit (main switch set 0),
- wait for all the components to stop,
- disconnect the mains power supply cable.

## Safety instructions

### WARNING

When the main switch is set to 0, some electrical connections may still be live.

Electrical shocks may cause severe injuries.

Before working on the pumping unit, it is recommended to disconnect the mains power supply cable.

### CAUTION

Rotary vane pumps use lubricants. It is recommended to request information from the manufacturer on the safety data sheets concerning the product used.

### DANGER

Before executing maintenance operations, it is necessary to verify the pumping conditions: toxicity, corrosion of the pumping gases.

### WARNING

The tightness of the product is guaranteed, when leaving the factory, for normal operating conditions.

If hazardous or corrosive gases are pumped, the user is responsible for ensuring the quality of tightness of the installation. This installation must prevent an over pressure in the pumping circuit.

### DANGER

The manufacturer has no control over the types of gases passing through this pump. Frequently, process gases are toxic, flammable, corrosive, explosive or otherwise reactive. Since these gases can cause serious injury or death, it is very important to plumb the exhaust of the pump to the facility's hazardous gas exhaust system which incorporates appropriate filters, scrubbers, etc., to insure that the exhaust meets all air regulations.

Check that pump is correctly connected to the equipment.

---

## Safety instructions

** DANGER**

For safety reasons, any accessories connected to the inlet and exhaust must be made of materials compatible with pumped gases. Ensure that the gases being used are compatible with pump's materials. See sheet  A 20

**CAUTION**

The pumping units must be used only in the industrial area, in compliance with the standard EN din 294 table 4 for persons over 14 years.

## Positioning the pumping system in the installation

### Unpacking



Hoisting ring

To keep your product in the clean condition in which it left our factory, we recommend to unpack the pumping system only on its assembly site.

- Remove the foam elements.
- Use the hoisting ring to take out the pumping system (see photo).

Do not discard the packaging until you have ensured that the pumping system has not been damaged during transport. It is advisable to keep the packaging for the redispatching.

### Pumping system list components

- 1 Pumping system (Turbopack or Turbostand)
- 1 oil mist eliminator following rotary vane pump model
- 1 hoisting ring
- 1 screen filter (depending on PTM)
- 1 copper seal if ATP equipped with CF-F flange
- 4 or 6 single claw clamps for the ISO-KF flange
- oil for primary pump (RVP)
- pumping system user's manual
- 1 roughing pump user's manual (RVP or ACP)
- 1 turbomolecular pumps ATP user's manual
- 1 vacuum gauge user's manual (option)
- 1 controllers user's manual (option)
- User's manual if option rotary vane pump isolation valve

### Handling

#### CAUTION

**Risk of toppling over: although compliance with EEC safety regulations is guaranteed (normal range  $\pm 10^\circ$ ), it is recommended to take precautions against the risk of toppling over during handling, installation and operation.**

## Positioning the pumping system in the installation

For all handling, use the hoisting ring.

- Remove the plastic cover from the top of the column.
- Screw the hoisting ring in one of the 4 threaded holes.

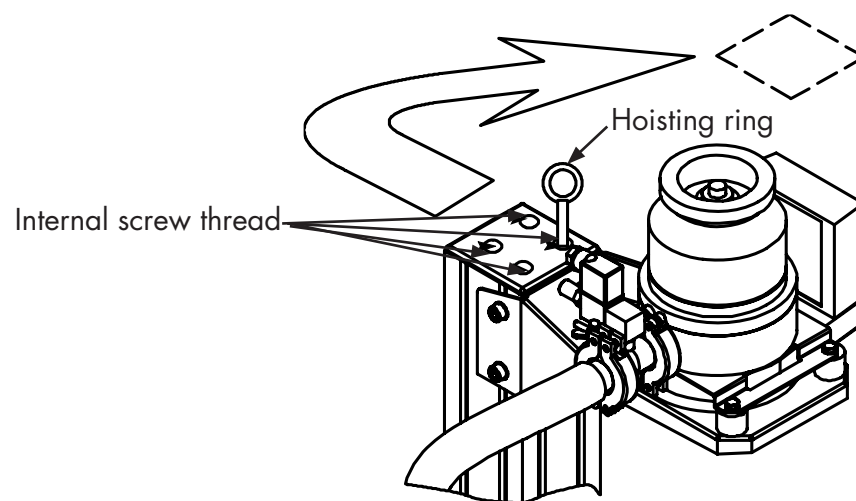

### **Pumping systems Turbopack / Turbostand immobilization**

- Settle pumping group on its jacks.
- Block the casters.

## Pumping system connection to an installation

### ⚠ CAUTION

Make sure that the parts or chambers connected to the pump inlet withstand a negative pressure of 1 bar relative to atmospheric pressure.

Also make sure that the maximum excess pressure does not exceed 1 bar relative to atmospheric pressure (for security).

### ⚠ CAUTION

For a given application, pump performance, vacuum characteristics, temperature and reliability depend on the following:

- assembly conditions, accessories filter.
- the oil used.
- mechanical connections: pipes, etc.
- maintenance frequency and quality.

For the assembly of the vacuum circuit, provide the accessories required for maintenance: valves, purges, etc.

### ⚠ CAUTION

Remove the protective parts blocking the inlet, exhaust (and, if applicable, purge) openings; these components prevent foreign bodies from entering the pump during transport and storage.

It is dangerous to leave them on the pump in operation.

## On the inlet

### ⚠ CAUTION

The equipment attachment devices should be sufficiently rigid to prevent potential risks in the event of failure of a rotary component or a violent shock on the pump (exceptional phenomena).

For this, use all the flange attachment holes.

When the ISO-KF flange is attached with claw clamps, use:

- at least 4 claw clamps for secondary pump with DN 63/100 flange
- at least 6 claw clamps for secondary pump with DN 160 flange

In case of CF-F flange use all attachment holes.

## Pumping system connection to an installation

**On the inlet** Remove the protective cover in the inlet of the ATP turbomolecular pump.  
Install the screen filter on the pump; connect the pump to the installation.

Different connection accessories are available in the Adixen catalog, including the attachment screws for the CF-F flanges.

The support flange can support a max. charge of 110 lbs/50kg

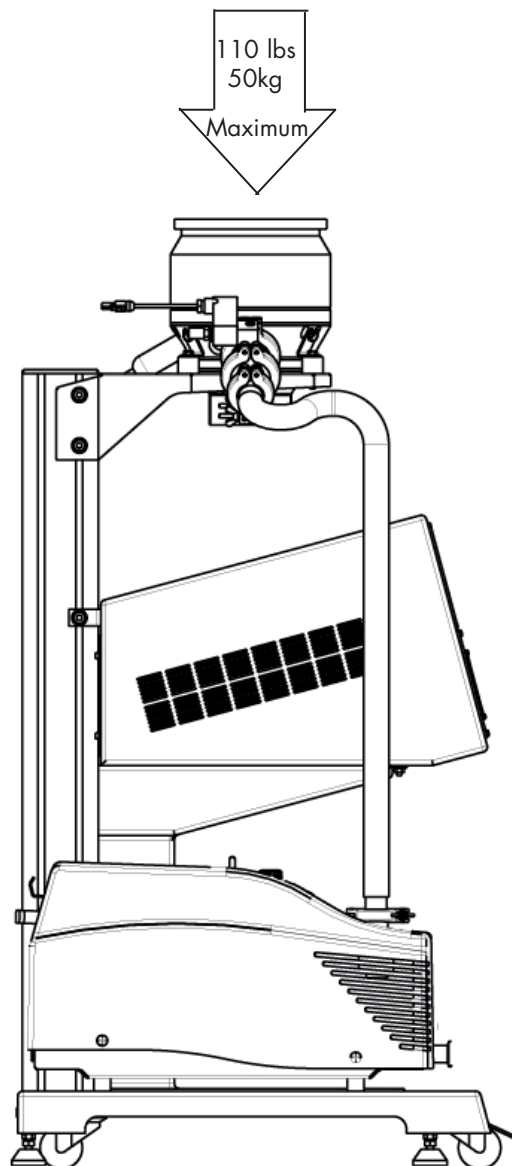

## Pumping system connection to an installation

### ATP position adjustment

#### ⚠ CAUTION

The inlet support flange position adjustment must be done before connecting the ATP inlet housing to the customer equipment. During this procedure, keep the ATP by holding up the support flange.

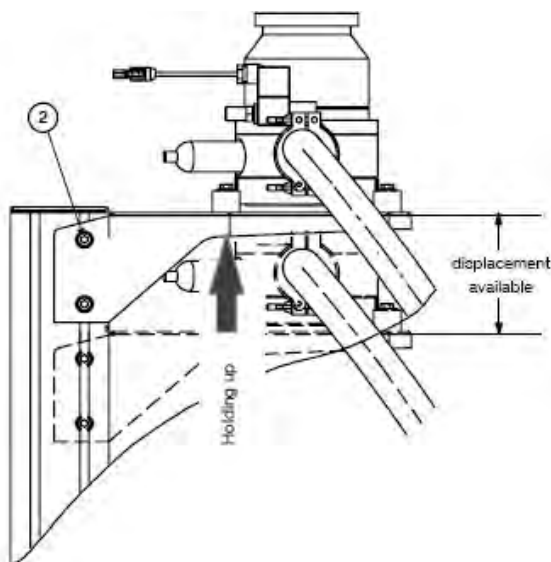

- During the procedure, keep manually the support flange.
- Unscrew the 4 lateral screws 2.
- Slide down slowly the support flange, See sheet **A 50**
- Secure the four lateral screws (2).

	Displacement available (Inch-mm)	
	Turbopack	Turbostand
ATP 80 DN 63 ISO-KF	3 / 75	7 / 175
ATP 80 DN 63 CF-F	3 / 75	7 / 175
ATP 100 DN 100 ISO-KF	3 / 75	7 / 175
ATP 100 DN 100 CF-F	3 / 75	7 / 175
ATP 150 DN 100 ISO-KF	2 / 55	6 / 155
ATP 150 DN 100 CF-F	2 / 55	6 / 155
ATP 400 DN 100 ISO-KF	1 / 35	5 / 135
ATP 400 DN 100 ISO-KF	1 / 35	5 / 135
ATP 400 DN 160 ISO-KF	1 / 35	5 / 135
ATP 400 DN 160 CF-F	1 / 35	5 / 135



## Pumping system connection to an installation

### On the exhaust

#### ⚠ CAUTION

It is recommended to connect the RVP or ACP pump exhaust to a smoke evacuation duct.

- If the pump exhaust orifice is connected to an extraction duct or an oil mist eliminator, the exhaust stop valve fitted in the pump exhaust orifice must be removed.
- At the pump exhaust, the evacuation circuit must be such that the resulting excess pressure in the tank is as low as possible:
  - for correct pump operation the max. exhaust pressure recommended should be 1.125 Torr (1.5 Bar) absolute pressure.

The pump exhaust orifice is equipped with DN 25 ISO-KF end fitting, or DN16 ISO-KF which can be used to fit various line components made of stainless steel, plastic, ... (see Adixen catalog).

Install the oil mist eliminator at the exhaust of the rotary vane pump using the connection accessories provided with the eliminator. (see oil mist eliminator user's manual).

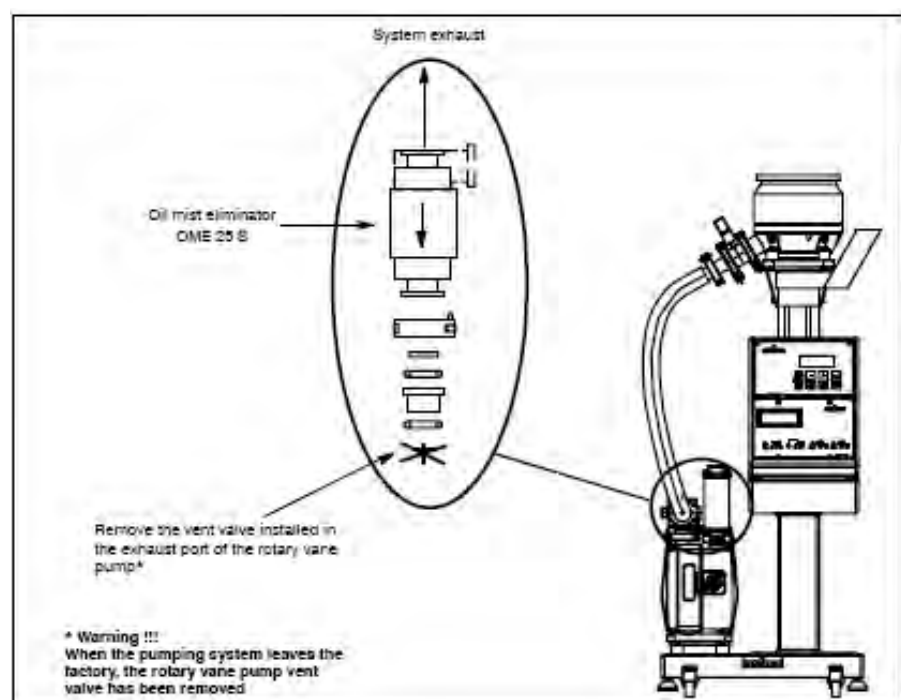

## Pumping system connection to an installation

### Purge connection ATP "C" version (option)

A filtered dry nitrogen supply with the following characteristics is required:

- dew point < 22 °C
- dust < 1µm
- oil < 0.1 ppm
- absolute pressure of 1 to 1.3 bar

Remove the blank flange placed on the DN16 purge fitting of the turbomolecular pump, and connect the nitrogen pipe with a DN 16 fitting (see the design hereafter).

A built-in safety valve controls the pressure and guarantees a flow rate of 50 sccm.

Different connection accessories can be ordered in the Adixen catalog.

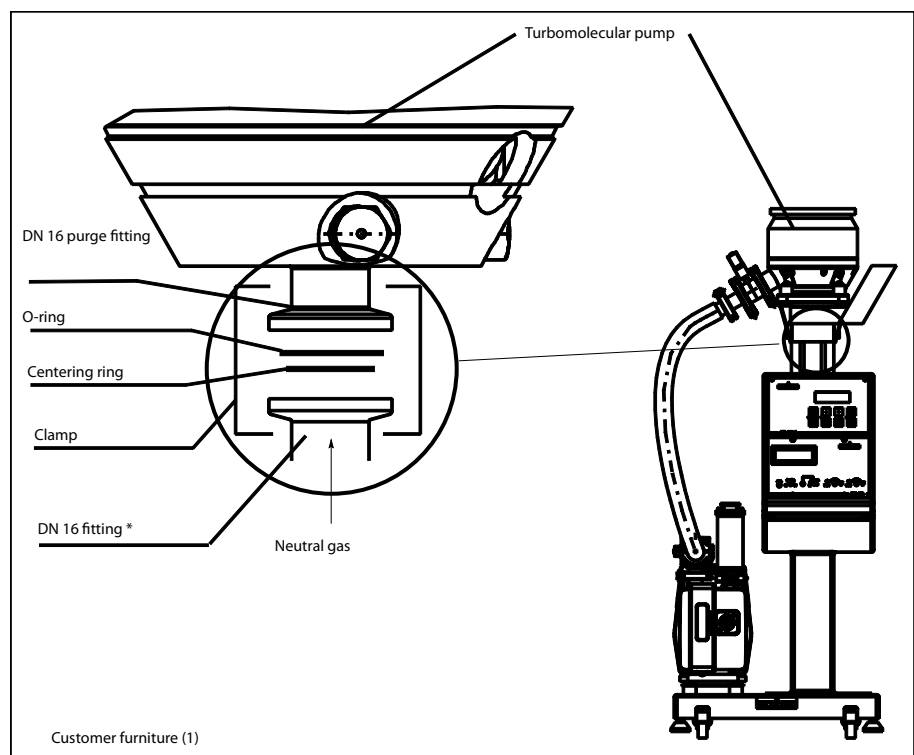

## Pumping system connection to an installation

### Water line connections on ATP water cooled (option)

It is recommended to use cooling water with the following characteristics:

- PH between 7.5 and 11
- hardness < 7 milli-équivalent/dm<sup>3</sup>
- resistivity > 1500  $\Omega \cdot \text{cm}$
- solid pollution < 100 mg/dm<sup>3</sup>
- max.pressure = 7 bars
- temperature de 10 °C to 25 °C (standard and chemical models)

Connect the cooling circuit with a flexible pipe int  $\varnothing$  4 mm – ext  $\varnothing$  6 mm (supplied by customer).

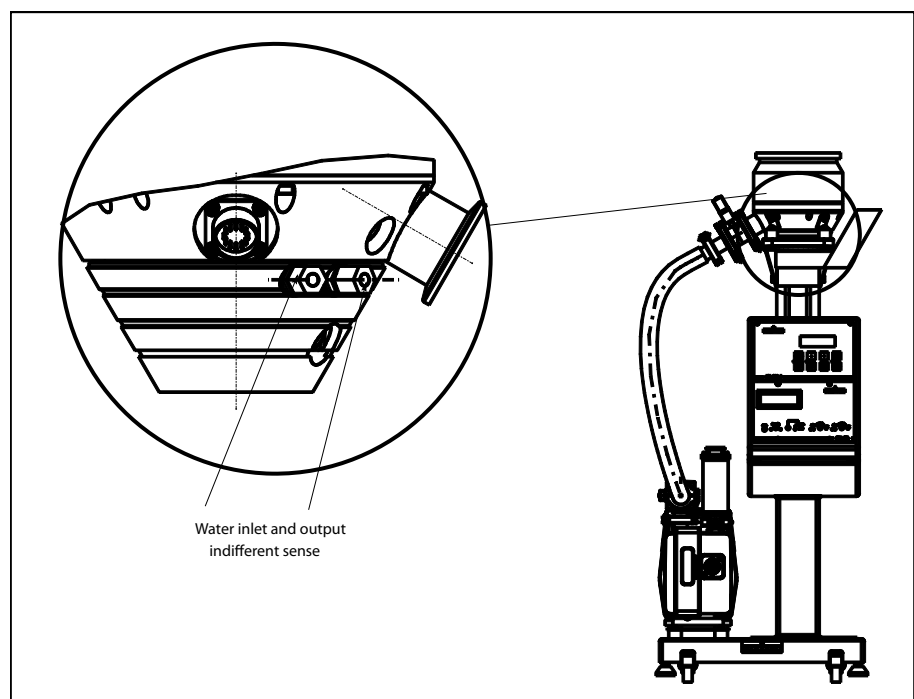

The water flow rate is 0.2 to 1 l/mn for water at 15 °C at an ambient temperature of 25 °C.

## Accessories connection

### Vacuum gauge connection

Connect the gauge on the customer installation with the required accessories.

	Seal	Collar	Fitting kit (washer + nut + bolt)
DN 25 ISO KF + ring seal holder	068229	083264	-
DN 16 ISO CF-F	303288 (1)	-	303414 (2)
DN 40 ISO CF-F	303289 (1)	-	303415 (2)

(1) kit of 10 parts

(2) kit of 25 parts ( 25 washers, 25 nuts, 25 bolts)

To supply this accessory, it is necessary to order the gauge cable separately  
See sheet  A 60

### Controller connection



Remove blank plate for access to the J4 connectors

- Switch off the pumping system by positioning switch CB1 to "0".
- Unscrew the 4 fixing screws of the plate and remove it.
- Replace the plate with the 1/2 rack measure adaptor and fixed it with the 4 fixing screws.
- Pass the gauge cable through the hole located at the rear of the frame.
- Connect the main cable and the gauge cable to the connectors at the rear of the controller.
- Connect the main cable of the controller to the J4 connector.

## Accessories connection

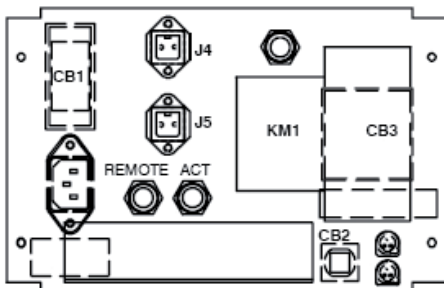

Pumping system electrical cabinet (inside view)



ACM 2000

← ACT controllers

← Controllers (accessory /option)



ACS 2000

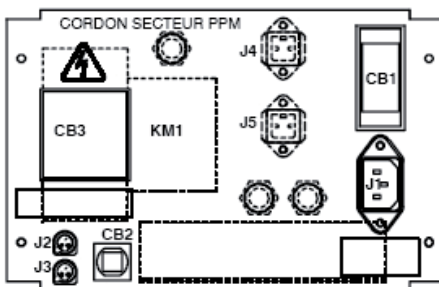

Pumping system electrical cabinet (outside view)

- Connect the main cable of the controller to the J4 connector inside the frame location.
- Install the controller in the frame of the pumping system and fixed it with 4M3x10 screws

### Vent valve connection

The vent valve is installed at the ATP exhaust, (DN 25 ISO-KF or DN 40 ISO-KF connection).  
(Different connection accessories are available in the Adixen catalog).

Connect the electrical cable to the J3 connector at the rear of the frame. It is powered in 24 VDC and controlled by the ACT controller.

### ISV 25 Isolation valve connection

The ISV 25 isolation valve is installed at the rotary vane pump inlet (DN 25 ISO-KF connection).  
(Different connection accessories are available in the Adixen catalog).

Connect the electrical cable to the J2 connector at the rear of the frame.  
It is powered in 24 VDC and controlled by the electric cabinet.

---

## Rotary vane pump oil filling

**Oil filling** Adixen 5 to 21 m<sup>3</sup>/h SD series rotary vane pumps are tested in the factory with **A200** oil.

At delivery, the primary pump is drained. There is some residual oil remaining in the functional bloc.

**Our rotary vane pumps are tested in the factory with A200 oil : it is recommended to use the same oil during operation. To change the type of oil, refer to the RVP User's Manual.  
In all cases, follow the recommendations of the user's manual RVP for the choice of oil to be used.**

**The rotary vane pump is delivered drained. The oil is contained in separate bottles.**

When changing the type of oil, carry out the special preparation procedure for the pump, then, remove the filling cap and fill with oil until the oil reaches the highest mark on the sight glass. (see RVP User's Manual).

This operation must be performed with the pump switched off.

## Pumping system electrical connection

### ⚠ CAUTION

Check that the pumping system is wired according to the line voltage. Refer to the label located at the bottom of the electrical cabinet rear panel. See the following page for rotary vane pump voltage change.

### ⚠ CAUTION

Check that the roughing pump is filled with oil. Proceed as follows:

- in case of RVP, fill the pump with oil following instructions listed in  B 40
- in case of ACP, the oil charge has been introduced in the pump at factory, don't readjust the oil level.

- Connect the main cable to the J1 connector.
- Switch on CB2 and CB3 at the rear of the frame.
- Switch on CB1 at the rear of the frame to start the pumping system to initialize the ACT controller.

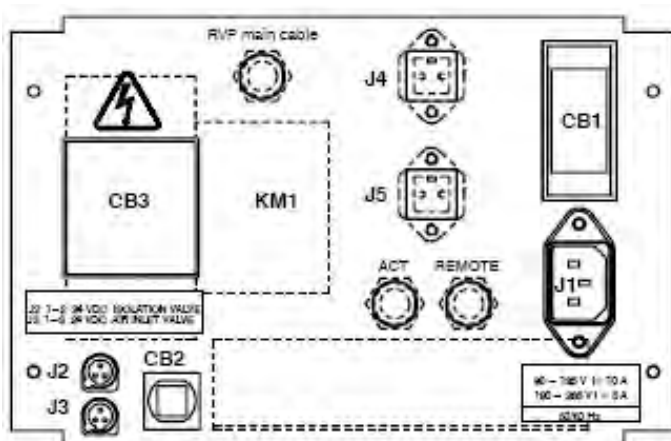

Pumping system electrical cabinet  
(rear of the frame)



## ACT 200 T / ACT 600 TH controller starting-up

### ACT 200 T or ACT 600 TH controller starting

Once the various electrical connections have been made, set the CB1 switch of the electrical housing on the rear panel of the frame. The ACT controller initializes start-up. The controller performs a self-test and identifies the pump to which it is connected. The initialization time is approximately 12 seconds.

Display initialization



Indicator light test: lit in succession.



The equipment is identified : the program versions are displayed.

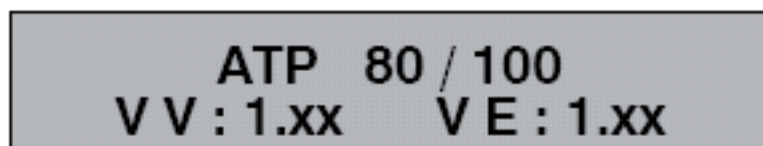

The pump operation time and speed are displayed.





# ACT 200 T / ACT 600 TH controller starting-up

## Parameter settings keys

Parameter setting access



- Used to access the parameter setting mode.
- Used to exit the various menus without validating the functions.

Selection



- Used to move in the menus, or from one parameter to another.
- Used to select or adjust the value of the selected parameter.

Validation



- Used to validate the selection of a menu, parameter or value.



- Used to exit the menus and return to the pump parameter display (on ACT 600 TH).

## Configure the parameters for the application using the various menus

Enter the sub-menus by pressing:

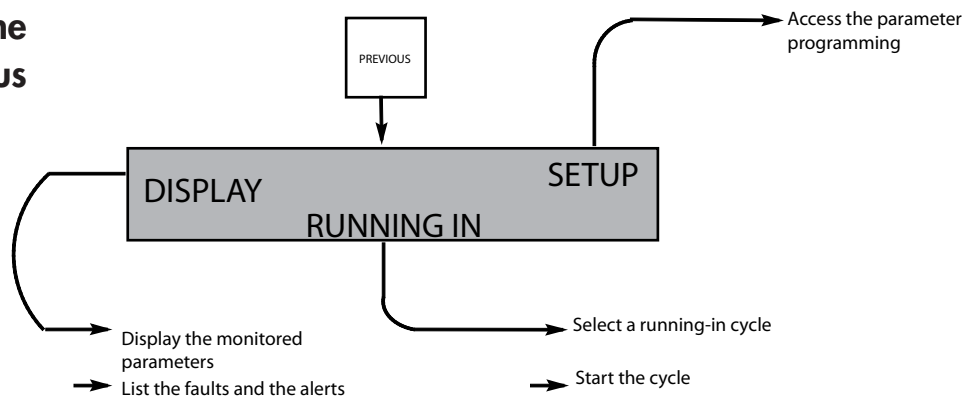

Refer to ATP user's manual for a list of all the available menus.

## Safety instructions

### Preliminary recommendations

- Read attentively the safety instructions outlined in sheet  B 10

Do not move or induce a shock on a pump in operation. This could result in a risk of jamming.

### CAUTION

When the secondary pump is new, or after a storage for a shutdown period of 3 months or more, we recommend to start the secondary pump for approximately 10 min at atmospheric pressure by setting the main switch to 1. Then let the pump running for 20 minutes at ultimate pressure. The purpose of this slow rotation is to distribute the grease regularly in the ball bearings.

For this operation, inlet and pump exhaust are open to atmosphere.

- Disconnect the ATP turbomolecular pump exhaust
- Position rotary vane pump motor switch on "0", or disconnect the ACP power cable.
- Press "START" in front of the ACT controller.
- When the running-in is performed, connect the rotary vane pump to the ATP and position the rotary vane pump motor on "1". In case of ACP, connect the power cable.

### WARNING

It is dangerous to access the rotor of a turbomolecular pump on which the intake is not connected. Even if the pump is not powered, it may be driven by another pump in operation.

Severe cuts may be caused on contact.

Before working on the pumping unit, it is recommended to:

- stop the pumping unit (main switch set 0),
- wait for all the components to stop,
- disconnect the mains power supply cable.

### CAUTION

The performances and operating safety of this product can only be guaranteed if it is used in compliance with its normal use.

---

## Safety instructions

**⚠ CAUTION**

The vacuum pump is also a compressor: incorrect use may be dangerous. Study the user manual and follow the safety instructions before starting the pump.

**⚠ WARNING**

The tightness of the product is guaranteed, when leaving the factory, for normal operating conditions.  
If hazardous or corrosive gases are pumped, the user is responsible for ensuring the quality of tightness of the installation. This installation must prevent an over pressure in the pumping circuit.

**⚠ CAUTION**

The pumping units are designed so as to prevent thermal risks for the user's safety.  
However, particular operating conditions may induce temperatures justifying particular caution on the part of the user (outer surfaces > 70 °C on exhaust connections).  
Burns may be caused on contact.  
Wear protective gloves before repair work.

## Pumping system utilization

### CAUTION

Check that the rotary vane pump is filled with oil.

### CAUTION

If it's the first ATP start-up, perform a running in procedure. Instructions listed  C 00

### Ambient operating temperature

If the ATP is cooled by air or natural convection  
 $15\text{ }^{\circ}\text{C} < T < 35\text{ }^{\circ}\text{C}$

If the ATP is cooled by water:  $15\text{ }^{\circ}\text{C} < T < 50\text{ }^{\circ}\text{C}$   
 See sheet  A 50

### Start-up procedure

Once the various electrical connections have been made, switch on the CB1 switch on the rear panel to initialize the ACT controller. The pump operation time and speed are displayed, as shown

**52 H ORPM  
READY TO START !**

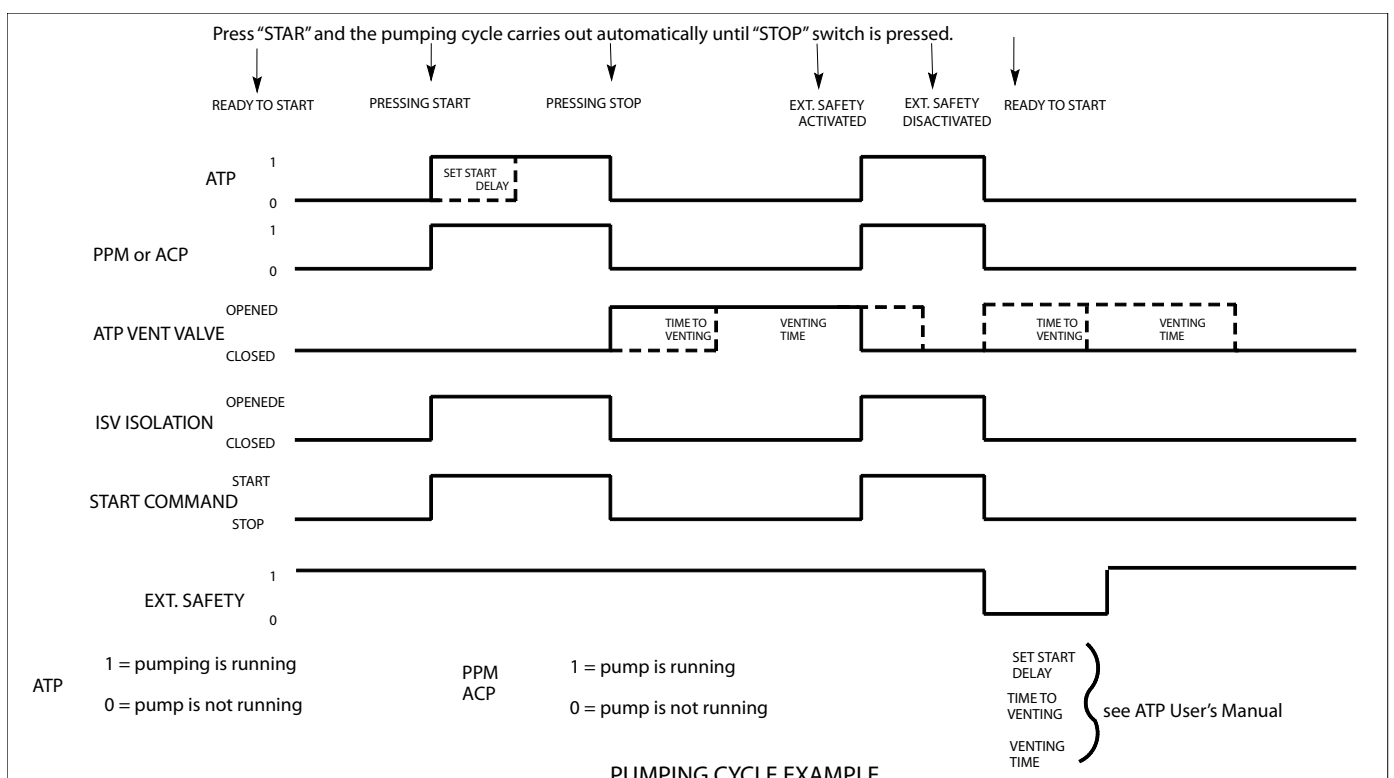

## Safety instructions

This chapter describes the main preventive maintenance operations and provides a guide for first diagnosis in the event of an incident.

### CAUTION

**Standard precautions before any maintenance operation:**  
Before performing a maintenance operation, switch off the pump by setting the main switch to "O" and disconnect the mains cable.

### CAUTION

**Before any operation, check the pumping conditions of the installation:**  
toxicity, corrosion, possible radioactivity of the pumped gases.

### WARNING

**Product tightness is guaranteed upon leaving the factory for normal operating conditions. It is the responsibility of the user to ensure that the level of tightness is maintained when pumping dangerous gases.**

Depending on the case, we recommend:

- To purge the installation with dry nitrogen.
- To wear gloves, protective glasses and, if necessary, a breathing mask.
- To ventilate the premises well.
- Not to dispose of residue but, if necessary, to have it destroyed by a qualified organization.
- Certain gases can become corrosives and toxic when trapped in oil. Always wear protective gloves when handling used and Dirty pump oil, drain it into a closable container, and do not breathe the fumes of the oil. Always use fully self-contained breathing apparatus.
- Always dispose of used dirty oil, or sub-products properly and in compliance with all local, state and federal environmental laws and regulations.

### CAUTION

**After a complete maintenance operation of the pump or on the installation, it is recommended to perform a tightness test with helium.**

## Remedies and troubleshootings

### Pumping system functioning incidents

Incident	Cause	Consequence	Remedies
<b>No event occurs after power on:</b> <ul style="list-style-type: none"> <li>• No display,</li> <li>• Indicators do not light.</li> </ul>	<ul style="list-style-type: none"> <li>• CB1 circuit breaker poor connection.</li> <li>• Defective power cable J7.</li> <li>• Fuses are burned.</li> </ul>	No mains current in the electrical cabinet. The electrical cabinet is not powered. Not functioning.	Reset the CB1 circuit breaker. <ul style="list-style-type: none"> <li>• Check the power cable J7.</li> <li>• Check the fuses of the ACT.</li> <li>• Call the Service Center.</li> </ul>
<b>D01 :</b> <b>EXT. SAFETY.</b>	<ul style="list-style-type: none"> <li>• CB2 circuit breaker poor connection.</li> <li>• CB3 circuit breaker poor connection.</li> <li>• No 24 VDC voltage</li> <li>Defective power.</li> </ul>	Stop the pumps. If ISV25 and/or vent valve are installed, the pumps are reset at atmospheric pressure.	<ul style="list-style-type: none"> <li>• Reset CB2.</li> <li>• Reset CB3.</li> <li>• Call the Service Center.</li> </ul>
<b>ATP doesn't reach its nominal speed (pre-selected speed).</b>	<ul style="list-style-type: none"> <li>• ISV is not open.</li> <li>• Roughing pump is not running.</li> </ul>		<ul style="list-style-type: none"> <li>• Check J2 connection.</li> <li>• See User's Manual RVP (Maintenance chapter / remedies and troubleshootings).</li> </ul>
<b>ATP doesn't reach its nominal speed (pre-selected speed).</b>	<ul style="list-style-type: none"> <li>• Bad connection or coil defective.</li> </ul>	Pump is permanently at atmospheric pressure because the air valve is open.	<ul style="list-style-type: none"> <li>• Check J3 connection or change the valve coil.</li> </ul>
<b>No display on the vacuum gauge controller.</b>	<ul style="list-style-type: none"> <li>• Vacuum gauge controller are not powered.</li> </ul>		<ul style="list-style-type: none"> <li>• Check J4 and J5 connection.</li> <li>• If the fault continues, to refer the vacuum gauge manuals.</li> </ul>

## Remedies and troubleshootings

**ATP functioning incidents** Check the warning message on the controller display.

Incident	Cause	Consequence	Remedies
<b>WO1 : GREASING</b>	<ul style="list-style-type: none"> <li>The authorized limit for ball bearing maintenance time has been reached. (M=0 or M=1)</li> </ul>		<ul style="list-style-type: none"> <li>Regrease the pump and initialize the maintenance counter. (see User's Manual ATP Series)</li> </ul>
<b>WO2 : PUMP MAINTEN.</b>	<ul style="list-style-type: none"> <li>Pump maintenance required.</li> </ul>	<ul style="list-style-type: none"> <li>Bearing must be changed.</li> </ul>	<ul style="list-style-type: none"> <li>Contact the Service Center.</li> </ul>

On the ACT controller, other displays can appear (See User's Manual ATP Series Maintenance chapter).

**Rotary vane pump functioning incidents** Check rotary vane pump performance and oil color through the oil level sight glass (see RVP User's Manual).

**ACP roughing pump functioning incidents** Check the dry roughing pump performance (see ACP User's manual).

---

## Maintenance

**Turbomolecular pump  
ATP maintenance  
interval** Before intervention, consult using precautions. See  **D 00**

Bearing lubrication frequency and ball bearings replacement are signaled by the ACT display. (see User's Manual ATP series).  
See sheet  **F 20**

**Rotary vane pump  
maintenance  
periodicity** Refer to RVP User's Manual.

### Draining of the rotary vane pump

- Disconnect the rotary vane pump main cable.
- Hold lightly the pumping system to access to the screws.
- Unscrew these 4 screws.
- Slide the rotary vane pump along the frame to easily access to the drain plug.
- Drain the pump following the User's Manual instructions RVP series.
- Then, realize the oil charge filling following the instructions listed in  **B 40**
- Position the rotary vane pump in its initial position and secure the 4 screws (under the frame).

**ACP Dry roughing  
pump maintenance  
periodicity** Refer to the ACP User's Manual

### ACP Draining

- The ACP draining is performed by a Service center.

**Electrical component  
maintenance** See Electrical diagram sheet  **F 10**.



---

## Spare parts - Instructions of use

### Replacement of parts and use of non genuine parts

Our products are designed to comply with current EC regulations and guarantee optimal operating conditions with maximum safety conditions for the user.

**Any modification of the product made by the user is liable to lead to non-compliance with the regulations, or even to put into doubt the performance of the product and the user's safety.**

Replacement of defective components with parts that are not genuine, jeopardizes the initial safety conditions of the equipment.

**In such cases, the EC declaration of conformity becomes null: The manufacturer withdraws responsibility for such operations.**

Besides, counterfeiting and unfair trading of parts are condemned under civil and criminal laws.

The manufacturer urges the user not to use «imitation parts», or the misappropriation and pirating of intellectual property performed by some dishonest operators.

The manufacturer supplies maintenance components, spare parts or kits to perform the maintenance of its products (  F).

## Electrical box schematic diagram

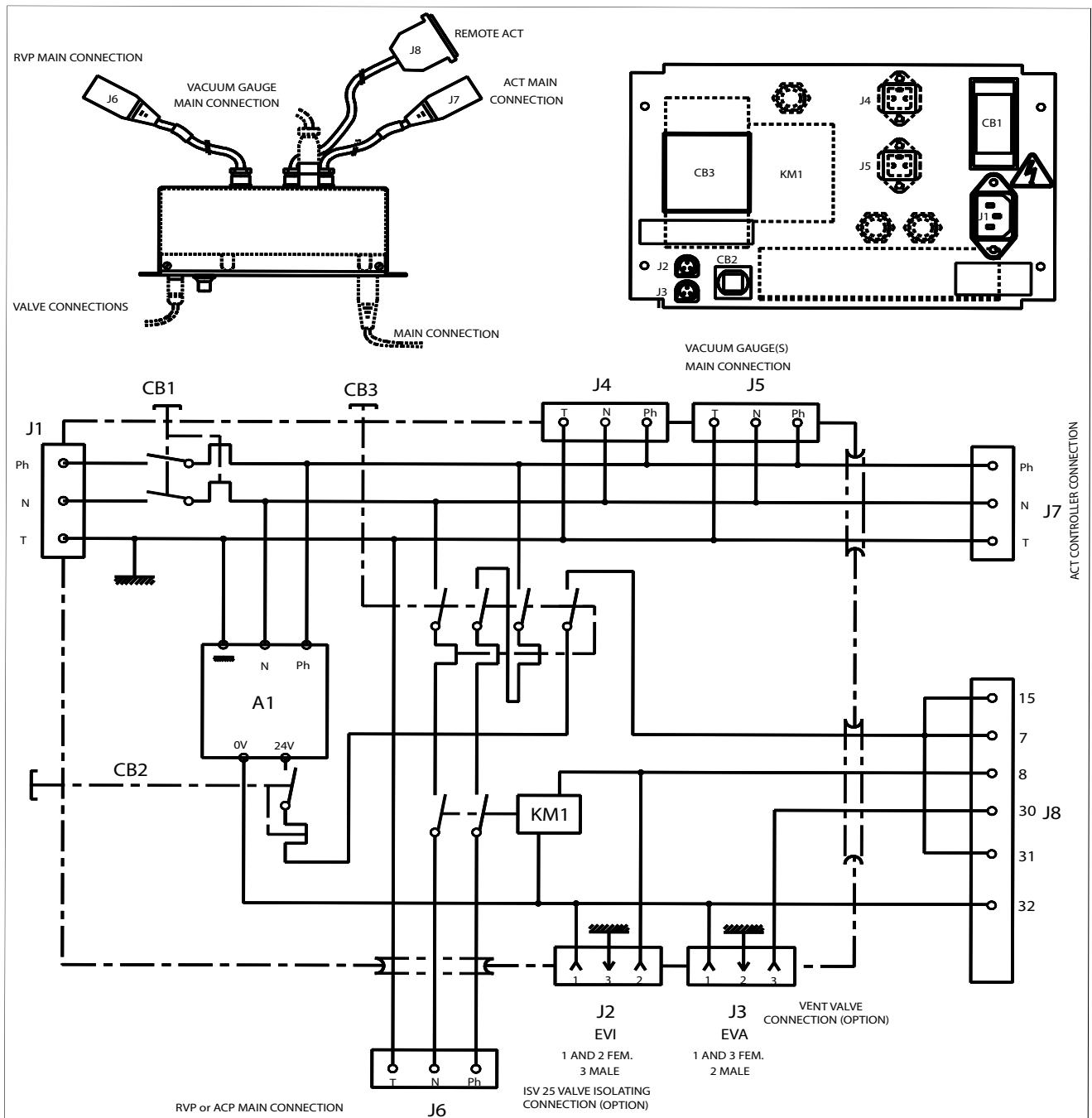

## Maintenance parts

### Packagings

	P/N
Turbopack	111014
Turbostand	111013

### User's manuals

	P/N
ATP 80/100/150/400 ATP80C/100C/150C/400C	102710
RVP 2005/2010/2015/2021 RVP 2005C/2010C/2015C/2021C	103275
User's Manual ACP series Version 1 (until 31/12/2007)	109125
User's Manual ACP series Version 2 (from 01/01/2008)	112369

### Power cables

	P/N
Europe	103566
Italy	104758
Switzerland	103718
Great Britain	104411
U.S.A. / Japan 110 V / 130 V 50/60 Hz	103567
U.S.A. / Japan 200 V / 240 V 50/60 Hz	103898



### DECLARATION OF CONFORMITY

We, Alcatel Vacuum Technology France,  
98, Avenue de Brogny, BP 2069  
74009 ANNECY FRANCE

#### ISO 9001 CERTIFIED

declare under our sole responsibility that the following products

TURBOPACK  
TURBOSTAND

to which this declaration relates are in conformity with the following European Directives:

89 / 392 / EEC	Machinery Directive
89 / 336 / EEC	Electromagnetic Compatibility Directive
73 / 023 / EEC	Low Voltage Directive
93 / 068 / EEC	Council Directive

The standards, normative documents, and/or specifications to which the products comply are :

NF EN 60204-1	Safety of machinery / electrical equipment of machinery.
NF EN 61010-1	Safety requirements for electrical equipment for measurement control and laboratory use.
NF EN 292-1	Safety of machinery / basics.
NF EN 292-2	Safety of machinery / general principles for design.
IEC 34 parts 1, 5, 11	General Requirements for Rotating Electrical Machines.
NF EN 55022 Lim A	Limits and methods of measurement of radio disturbance characteristics.
NF EN 61000-4-2	EMC / Immunity to electrostatic discharges.
NF EN 61000-4-4	EMC / Immunity to transient burst.
ENV 50140	EMC / Immunity to Radiated electromagnetic Field.
ENV 50141	EMC / Immunity to conducted disturbances induced by radio-frequency fields.
NF EN 61000-4-11	EMC / Voltage dips, short interruptions and voltage variations immunity test.
NF EN 50081-2	EMC / Generic emission standard / Industrial environment.
NF EN 50082-2	EMC / Generic immunity standard / Industrial environment.

Mr J.Y. GUEGAN, Chairman and Managing Director

Made in Annecy, 16/12/99

LANGUE : ANGLAIS

## Safety questionnaire

### Procedure for returning ADIXEN products.

You wish to return an Adixen product for maintenance. The equipment will be dismantled and possibly cleaned by a technician from our Service Centre.

In compliance with European Community's L360 directives, French labor code L231 - R231 and Federal OSHA Safety Standard 1910-1200, Alcatel Vacuum Technology requires this form to be completed to preclude the potential health risk to its service personnel that can occur when receiving, disassembling, or repairing potentially contaminated products.

**Equipment returned without this form completed and secured to outside of package will be returned to customer unprocessed.**

Equipment must be drained of fluids and residue, securely packaged and shipped prepaid. Concerning the closing of the ports (inlet & outlets of the product), metallic airtight blank flanges should be used if toxic or copper gases have been pumped.

We wish to draw your attention to the following points:

• **The risk may be of the following nature:**

- **Chemical:** Danger to health, risks of explosion, fire, risks for the environment. Please indicate the chemical formula and name of the gases or substances that have been in contact with the equipment (pump or detector).
- **Biological:** In case of contamination (such as pathogenic germs, micro-organisms (bacteria, viruses, etc.) classes 1 to 4 and group E), our Service center is currently unable to decontaminate and recycle such material without risk to the safety of our staff. Please contact us **before sending** the product to the Service center.
- **Radioactive:** In case of contamination, our Service Center is currently unable to decontaminate and recycle such material without risk to the safety of our staff. Please contact us **before sending** the product to the Service center.
- **Copper contamination:** Copper based by products formed in sputtering or etching processes are considered as a poison in some semi-conductor processes.

**If following inspection and quotation, customer elects to not proceed with repair, he will be subject to service fee to cover product decontamination, disassembly, cleaning and evaluation costs.**

**Please to fill in the following form, print it and attach it to the product before shipping to the service-repair office closest to you.**

**⚠ WARNING**

In the event of chemical contamination, please indicate the following gases or substances:

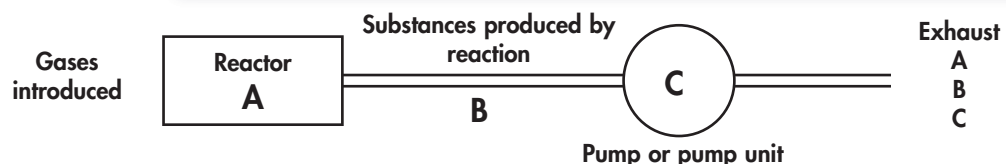

- Gases (or substances) introduced into the reactor and which may be found at the exhaust (A).
- Gases (or substances) resulting from the reaction or process (B).
- Gases (or substances) that may possibly be formed inside the pump (due to a thermodynamic or chemical reaction, condensation, deposition, precipitation, etc.) (C).

• **Precautions need to be taken before transferring contaminated products.**

Please contact Service Center for recommendations.

## QUESTIONNAIRE DE SECURITE - SAFETY QUESTIONNAIRE

Ce questionnaire est téléchargeable sur le site : [www.adixen.com](http://www.adixen.com)  
 This questionnaire can be downloaded from: [www.adixen.com](http://www.adixen.com)

### Procédure de retour des produits ADIXEN

(Ce formulaire ne peut être rempli et signé que par une personne habilitée)

### Procedure for returning ADIXEN products.

(This questionnaire is only to be filled in and signed by an authorized person)

<b>SOCIETE - COMPANY</b> Nom Société - Name of company : ..... Nom personne - Name of person : ..... (Qui remplit ce formulaire) - (Who has filled in questionnaire) Fonction - Position : ..... N° Tél. - Tel. no : ..... N° Fax - Fax no : ..... (Pour renseignements éventuels sur les produits utilisés) - (for any information on products used)	<b>EQUIPEMENT - EQUIPMENT</b> Description : ..... ..... N° de Série - Serial no : ..... Type de procédé - Type of process : ..... (Pour lequel l'équipement est utilisé) - (for which equipment is used) Date de l'expédition - Date of consignment : .....
<b>INTERVENTION - SERVICE</b> Intervention souhaitée (Révision, réparation,...) - Service required (overhaul, repair, etc.) : Type d'anomalie constatée - Type of anomaly observed :	
<b>PROCEDE CUIVRE - COPPER PROCESS</b> Produit utilisé sur un procédé Cuivre - Product used on a Copper process <span style="float: right;">Oui - Yes      Non - No</span>	
<b>ASPECT SECURITE - SAFETY ASPECT</b> L'équipement mentionné ci-dessus a été en contact avec les produits suivants - The above equipment has been in contact with the following substances : (nom et formule chimique) - (name and chemical formula)	
<b>Ces produits présentent un risque de nature - These substances present the following risks</b>	
<b>Chimique - Chemical</b> Toxique - Toxic                      Oui - Yes      Non - No Cancérogène - Carcinogenic      Oui - Yes      Non - No Combustible - Combustible        Oui - Yes      Non - No Corrosive - Corrosive              Oui - Yes      Non - No Explosive - Explosive                Oui - Yes      Non - No <b>Biologique - Biological</b> Oui - Yes      Non - No <b>Radioactive - Radioactive</b> Oui - Yes      Non - No <b>Autre - Other</b> (Vous reporter éventuellement à la page précédente) - (See preceding page if necessary)	Explication détaillée - Detailed explanation Si «Oui» risque de nature - If «Yes», what type of risk ..... ..... ..... ..... ..... ..... ..... ..... ..... .....
<b>SIGNATURE</b> <b>Vous avez répondu "Oui" à une des questions précédentes :</b> Je confirme que seules les substances précisées ont été en contact avec l'équipement sus-mentionné, et que les procédures de préparation, d'emballage, et de transport ont été respectées. <b>You have replied "yes" to one of the above questions:</b> I confirm that only the substances mentioned have been in contact with the above equipment and that the preparation, packing and transport procedures have been complied with.	Je confirme que le matériel sus-mentionné n'a été en contact avec aucune substance dangereuse, et a été vidé de son huile. (Si applicable) I confirm that the above equipment has not been in contact with any dangerous substance and has been emptied of oil. (If applicable)
Réponse "Oui" (fermeture étanche de l'aspiration et du refoulement) Reply "Yes" (seal inlet and outlet ports with blank flanges)	Réponse "Non" (sans risque) Reply "No" (no risk)
Nom - Name : ..... Fonction - Position : ..... Date : ..... Signature autorisée - Authorised signature : .....	Nom - Name : ..... Fonction - Position : ..... Date : ..... Signature autorisée - Authorised signature : .....
Tampon / Cachet Stamp / Seal	Tampon / Cachet Stamp / Seal

**CHINA**

Alcatel Vacuum Technology, Shanghai  
N°82 Lane 887 Zuchongzhi Road  
Zhangjiang High-Tech Park,  
Shanghai 201203  
China  
Tel. (86) 21 5027 0628  
Fax. (86) 21 3895 3815

**JAPAN**

Alcatel-Lucent Japan Ltd.  
1-9-4 Kita Shin-Yokohama  
Kohoku-ku  
Yokohama, Kanagawa 223-0059  
Japan  
Tel. (81) 3 6431 7130  
Fax. (81) 45 544 0049

**SWEDEN**

Adixen Sensistor AB.  
Box 76  
SE-581 02 Linköping  
Sweden  
Tel. 46 (0)13 35 59 00  
Fax. 46 (0)13 35 59 01

**FRANCE**

Alcatel Vacuum Technology France  
98, avenue de Brogny - BP 2069  
74009 Annecy cedex  
France  
Tel. (33) 4 50 65 77 77  
Fax. (33) 4 50 65 77 89

**KOREA**

Alcatel Vacuum Technology Korea  
447 Banwol-dong, Hawsung-si,  
445-330 Kyungki-do,  
South Korea  
Tel. (82) 031-206-6277  
Fax. (82) 031-204-6279

**TAIWAN**

Alcatel Vacuum Technology Taiwan  
No. 169-3, Sec.1, Kang-Leh Rd  
Song-Lin Village, Hsin-Feng 304  
Hsin-Chu County  
Taiwan - R.O.C.  
Tel. (886) 3 559 9230  
Fax. (886) 3559 9231

**GERMANY**

Alcatel Hochvakuumtechnik GmbH  
Am Kreuzeck 10 - Postfach 1151  
97877 Wertheim  
Germany  
Tel. (49) 9342 9610 0  
Fax. (49) 9342 9610 30

**NETHERLANDS**

ALCATEL Vacuum Technology Benelux  
Landzichtweg 60  
NL 4105 DP Culemborg  
The Netherlands  
Tel. (31) 345 478 400  
Fax. (31) 345 531 076

**UNITED KINGDOM**

Alcatel Vacuum Technology UK Ltd  
8 Bain Square - Kirkton Campus  
Livingston - West Lothian  
EH54 7DQ - Scotland  
United Kingdom  
Tel. (44) 1 506 418 000  
Fax. (44) 1 506 418 002

**ITALY**

Alcatel Vacuum Systems  
Via Trento, 30  
20059 Vimercate (Mi)  
Italy  
Tel. (39) 0396 86 38 55  
Fax. (39) 039 66 71 25

**SINGAPORE**

Alcatel-Lucent Singapore  
49 Jalan Pemimpin  
#01-02 APS Industrial Building  
577203  
Singapore  
Tel. (65) 6254 0828  
Fax. (65) 6254 7018

**USA**

Alcatel Vacuum Products  
67, Sharp Street  
Hingham - MA 02043  
USA  
Tel. (1) 781 331 4200  
Fax. (1) 781 331 4230

Alcatel Vacuum Technology France - 98, avenue de Brogny - BP 2069 - 74009 Annecy cedex - FRANCE  
Tel. (33) 4 50 65 77 77 - Fax. (33) 4 50 65 77 89  
Web site: [www.adixen.com](http://www.adixen.com)

**An Alcatel-Lucent Company**