

Operating Instructions

TPH 261 C / TPU 261 C
TPH 521 C / TPU 521 C

*Turbomolecular Pumps With Electronic
Drive Units For Corrosive Gas Processes*



	Page		Page
1. Safety Instructions	3	5. Monitoring Operations	15
1.1. For Your Orientation.....	3	5.1. Operations Display Via LED.....	15
1.2. Pictogram Definitions.....	3	5.2. Turbopump Temperature Monitoring.....	15
2. Understanding The Pumps	4	6. What To Do In Case Of Breakdowns?	16
2.1. Main Features.....	4	7. Maintenance	17
2.2. Differences Between The Pump Types.....	5	7.1. Replacing The Lubricant.....	17
3. Installation	5	7.2. Cleaning The Lubricating Pump.....	18
3.1. Preparations For Installation.....	5	8. Service	19
3.2. Installing The Pump, Connecting The High Vacuum Side	5	9. Technical Data	20
Fitting The Splinter Shield.....	6	9.1. Dimensions Diagram	21
3.3. Connecting The Fore-Vacuum Side	6	10. Accessories	23
3.4. Connecting The Cooling Unit.....	7	10.1. Lubricant.....	24
3.5. Connecting The Venting Valve.....	7	11. Spare Parts	24
3.6. Connecting The Casing Heating Unit.....	7	Drawings	26
3.7. Connecting The Sealing Gas Valve.....	7	Declaration of Contamination	27
3.8. Installing The Power Unit	7	Manufacturer's Declaration(last page)	
3.9. Connecting The Electronic Drive Unit TC 600.....	8		
3.10. Connecting The Remote Control Unit	9		
3.11. Connecting The Serial Interface RS 485	10		
Connection	10		
Connecting The RS 485	10		
3.12. Connections Diagram.....	11		
4. Operations	12		
4.1. Filling In The Lubricant.....	12		
4.2. Before Switching ON.....	12		
4.3. Switching ON	12		
4.4. Circulatory Lubrication.....	13		
4.5. Switching OFF And Venting.....	13		
4.6. Shutting Down For Longer Periods	13		
4.7. Operations With The DCU.....	13		
4.8. Operations With The Remote Control Unit.....	13		
Venting Release (Optional).....	14		
Motor, Turbopump	14		
Pumping Station	14		
Heating/Reset	14		
Standby.....	14		
Rotation Speed Setting Operations			
Via Input PWM	14		
Switching Outputs.....	14		

1. Safety Instructions

- ☞ Read and follow all instructions in this manual.
- ☞ Inform yourself regarding:
 - Hazards which can be caused by the pump;
 - Hazards which can be caused by your system.
 - Hazards which can be caused by the media being pumped.
- ☞ Avoid exposing any part of the body to vacuum.
- ☞ Observe the safety and accident prevention regulations.
- ☞ Regularly check that all accident prevention measures are being complied with.
- ☞ Do not operate the turbopump with open high vacuum flange.
- ☞ Do not carry out any unauthorised conversions or alterations to the turbopump with TC 600.
- ☞ When returning the turbopump observe the shipping instructions.
- ☞ Use at least 4 bracket screws to connect the high vacuum flange (ISO-flange).
- ☞ The turbopump must be anchored in accordance with the installation instructions.
- ☞ Do not disconnect the plug between the TC 600 and accessory components during operations.
- ☞ When the turbopump is open disconnect the voltage supply to the TC 600.
- ☞ When working on the turbopump, the high vacuum flange should only be opened once the rotor is at rest.
- ☞ When using sealing gas, the pressure in the hose connection should be limited to 2 bar via the overpressure valve.
- ☞ If a heater is in use temperatures of up to 120 °C can arise in the area of the high vacuum flange. Take care to avoid burns!
- ☞ During operations temperatures of up to 65 °C can arise in the lower part of the turbopump. Take care to avoid burns!
- ☞ Keep leads and cables well away from hot surfaces (> 70 °C).
- ☞ Operate the turbopump with TC 600 only in conjunction with the relevant Power Pack Unit (accessory).
- ☞ The unit has been accredited protection class IP 30. When the unit is operated in environments which require other protection classes, the necessary measures must be taken. Protection class IP 54 is afforded by retro-fitting a cover plate (accessory) to the TC 600.
- ☞ The mains connection must be subject to a safe connection to the PE (protection class 1).
- ☞ If the turbopump and the TC 600 are operated separately (only permissible with the agreement of the manufacturer) the turbopump must be connected to the PE.
- ☞ The cause of any operating voltage leakage to earth (red LED flashes) must be eliminated to avoid the danger of an electric shock.

1.1. For Your Orientation

On page 26 of this operating instructions you will find a drawing showing the connection options for the power unit and accessories.

Instruction in the text

- ➔ Working instruction: here, you have to do something.

Symbols used

The following symbols are used throughout in illustrations:

- Ⓜ High vacuum flange
- Ⓥ Fore-vacuum flange
- Ⓧ Venting connection
- Ⓦ Cooling water connection
- Ⓨ Air cooling
- Ⓩ Electric connection
- ⓐ Sealing gas connection

Abbreviations used

DCU = Operating and display control unit

TC = Electronic drive unit, turbopump

TPS = Power unit

TMP = Turbomolecular pump

Position numbers

The same pump and accessory parts have the same position numbers in all illustrations.

1.2. Pictogram Definitions



Danger of burns from touching hot parts.



Danger of an electric shock.



Danger of personal injury.



Danger of damage to the pump or to the system.



Danger of injury from rotating parts.

Modifications reserved.

2. Understanding The Pumps

2.1. Main Features

Turbopumps with the TC 600 form a complete unit. Voltage is supplied by power unit TPS (see "Accessories").

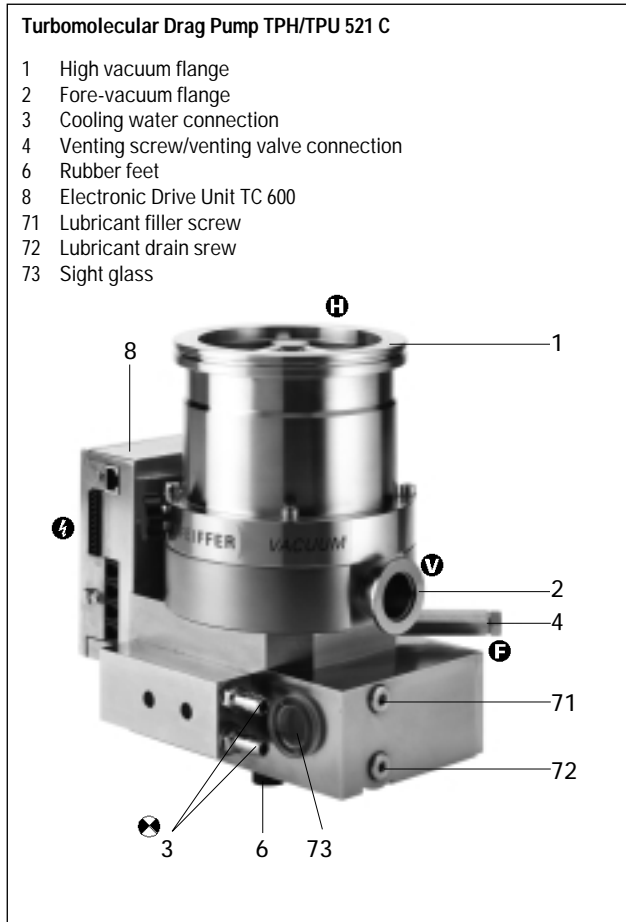

Cooling

Standard: Water cooling

Integrated protective measures against excess temperatures:

The Electronic Drive Unit TC 600 reduces the rotor rotation speed.

Bearings

High vacuum side: Wear free permanent magnetic bearing.

Fore-vacuum side: Oil circulatory lubricated ball bearing with ceramic balls.



The turbopumps must **not** be transported when filled with lubricant.

When being fitted into or dismantled from a system, turbopumps may only be positioned as shown in Section 3.2. Other positions can cause the pumps to be contaminated with lubricant.

Proper use

- The Turbomolecular Pumps may only be used for the purpose of generating vacuum.
- The Turbomolecular Pumps are designed to pump corrosive gases and vapours. Where corrosive gas processes are involved, gas bonding and particles which can damage the surfaces of the pump can be produced. The motor and bearing compartments have to be protected with sealing gas.
- The turbopumps may only be used to pump those media against which they are chemically resistant. For other media the operator is required to qualify the pumps for the processes involved.
- If the process produces dust, the maintenance intervals must be specified accordingly and sealing gas must be used.
- The turbopump must be connected to a backing pump in accordance with Section 3.3.
- Only PFEIFFER power units may be used to operate the TC 600. These power units guarantee voltage which is safely separated from the mains accordance with Standard EN 60 742. The use of other power units requires the express agreement of the manufacturer.
- The pumps may only be operated providing the ambient conditions in compliance with Protection Type IP 30 are observed.

Improper use

The following is regarded, inter alia, as improper:

- The pumping of explosive gases.
- Operating the pumps in areas where there is a danger of explosion.
- The pumping of gases and vapours which attack the materials of the pumps.
- The pumping of corrosive gases without sealing gas.
- The pumping of condensating vapours.
- Operations involving impermissibly high levels of gas loads.
- Operations with impermissibly high fore-vacuum pressure.
- Operations with improper gas modes.
- Operations involving too high levels of heat radiation power (see Section 9. "Technical Data").
- Operating the pump in environments which require a protection class superior to IP 30.
- The use of other power units or accessories which are not named in this manual or which have not been agreed by the manufacturer.
- The connection to power units with earthing of a direct voltage pole.

Improper use will cause all claims for liability and guarantees to be forfeited.

2.2. Differences Between The Pump Types

Feature	TPH 261 C	TPU 261 C	TPH 521 C	TPU 521 C
HV-flange	DN 100 ISO-K	DN 100 CF-F	DN 100 ISO-K DN 160 ISO-K	DN 100 CF-F DN 160 CF-F
HV-seal	Viton	Metal	Viton	Metal
Attainable final pressure	$< 1 \cdot 10^{-8}$ mbar (without baking-out)	$< 1 \cdot 10^{-10}$ mbar (with baking-out)	$< 1 \cdot 10^{-8}$ mbar (without baking-out)	$< 1 \cdot 10^{-10}$ mbar (with baking-out)

3. Installation

3.1. Preparations For Installation



Do not carry out any unauthorised conversions or alterations to the turbopump.

- Pumps must be filled with lubricant before being operated (see Section 4.1.).
- The turbopumps must **not** be transported when filled with lubricant.
- The maximum permissible rotor temperature of the pump is 120 °C. If the vacuum chamber or parts in the vacuum chamber are heated, the values stated in the technical data relating to the level of heat which may be radiated into the pump must not be exceeded. If necessary, suitable shielding must be fitted in the vacuum chamber before the turbopump (constructional suggestions available on request).
- Only remove the blank flange from the high and for-vacuum side immediately before connection.
- Where magnetic fields of > 5.5 mT (TPH/U 261 C) and > 5.0 mT (TPH/U 521 C) are involved suitable shielding must be provided (available on request).
- If the pump is baked out, the heating sleeve and the body of the pump must be insulated to prevent burns from accidental contact.
- In the event of a sudden standstill of the rotor, torques of up to 750 Nm (TPH/U 261 C) and up to 2680 Nm (TPH/U 521 C) can arise and these must be taken up by the turbopump and frame. Pumps must be anchored as follows:
 - ISO flange with 4 bracket screws,
or
 - CF flange with the complete set of M8 screws,
or
 - underside of the pump with 4 screws M8,
screws quality 8.8..

3.2. Installing The Pump, Connecting The High Vacuum Side

Important

The utmost cleanliness must be observed when fitting all high vacuum parts. Unclean components prolong the pumping time.

Use a splinter shield

The use of a splinter shield in the high vacuum flange protects the turbopump against foreign bodies coming from the vacuum chamber but does reduce the volume flow rate of the pump by approximately 15%. For fitting splinter shields please refer to "Fitting the splinter shield".

The high vacuum side can be flanged onto the vacuum chamber either directly or via a bellows or a vibration compensator (see "Accessories").

Connecting via bellows

If the high vacuum side is to be flanged via a bellows, the turbopump must be secured for example via the holes on the underside of the turbopump (please see dimensions). The fastening must be able to withstand the torque referred to in Section 3.1..

Connecting Via A Vibration Compensator



The maximum permissible temperature at the vibration compensator is 100 °C.

Where a vibration compensator is in use, a freely suspended turbopump can be flanged onto the vacuum chamber. Additional fastening is unnecessary.

Directly Flanging The Pump

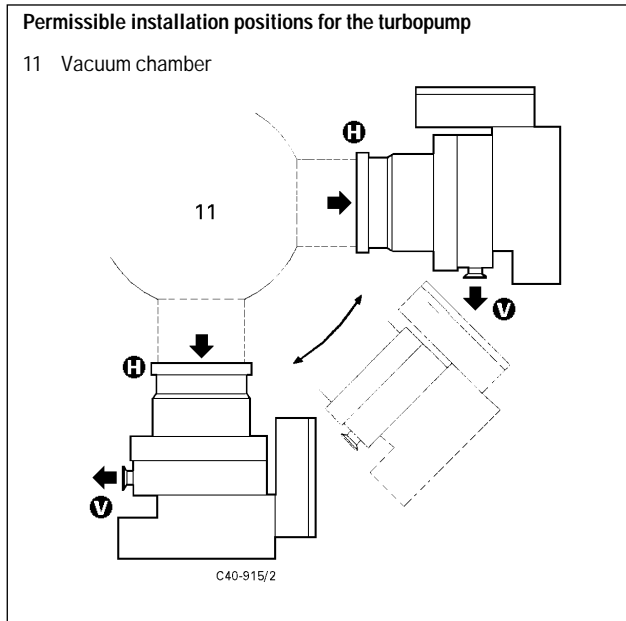

CAUTION The loading capacity of the high vacuum flange is TPH/TPU 261 C max. 500 N (equivalent to 50 kg) and TPH/TPU 521 C max. 1000 N (equivalent to 100 kg).

Asymmetric loading on the high vacuum flange must be avoided.

If the pump is being installed horizontally:
The fore-vacuum flange of the turbopump must be aligned vertically downwards (maximum deviation $\pm 20^\circ$), otherwise the turbopump could become dirty and the lubricating pump not properly function.

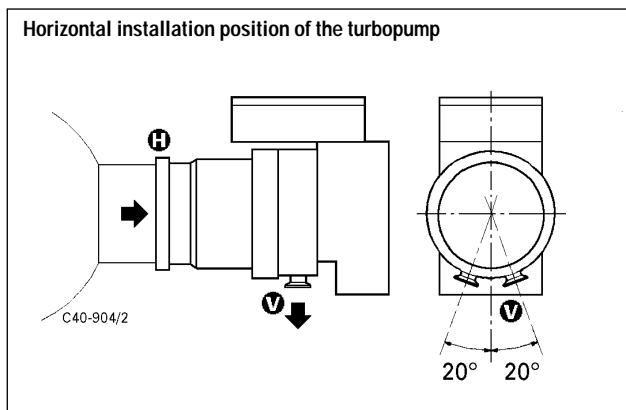

CAUTION No forces from the piping system must be allowed to act on the pump where turbopumps are anchored.
Suspend or support all pipes to the pump.

Fitting The Splinter Shield

- Insert the splinter shield in the high vacuum flange in such a way that the corrugation of the strainer points outwards.
- ➔ Bend the clamping lugs slightly outwards so that subsequently the splinter shield is seated firmly in the high vacuum flange (to avoid noise).
 - ➔ Insert the splinter shield in the high vacuum flange while pressing the clamping lugs slightly inwards.
 - ➔ Press the outer ring of the splinter shield up to the limit stop point in the high vacuum flange.

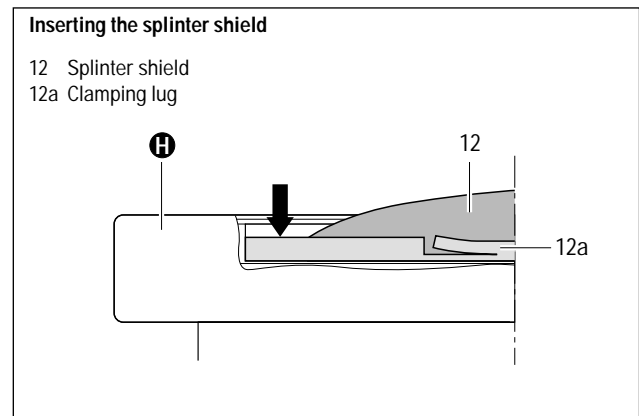

3.3. Connecting The Fore-Vacuum Side

Backing pump: Fore-vacuum pressure ≤ 1 mbar
Recommendation: UniDry or Rotary Vane Vacuum Pumps from the PFEIFFER range.

Connecting the backing pump

All connections of the fore-vacuum line: With the usual small flange components or screwed hoses.

CAUTION Be sure to conduct away the exhaust gases from the backing pump. Do not reduce the free cross section of the fore-vacuum flange with following components.

BEWARE The exhausted process gases and vapours can represent a health hazard and can also be environmentally damaging.
Comply with all the gas manufacture's safety instructions.

- ➔ With rigid pipe connections: Fit a bellows in the connecting line to reduce vibration.
- ➔ The electrical connection of the backing pump is made via a relay box (Accessory) whose control line is connected to "FV PUMP" on the TC 600.

Please refer to Operating Instructions PT 800 030 BN for details on the relay box, backing pump and its installation.

3.4. Connecting The Cooling Unit

The Turbopumps TPH/TPU 261 C and TPH/TPU 521 C are water cooled as standard.

Please refer to Operating Instructions PM 800 546 BN for installation for water cooling.

3.5. Connecting The Venting Valve

The venting valve (Accessory) provides automatic venting in the event of a power failure and switching off.

Fitting the venting valve

- ➔ Unscrew the venting screw from the venting connection of the turbopump.
- ➔ Screw in venting valve with seal (USIT ring) on hexagonal SW 14.

Electrical connection

- ➔ Plug control lead 42a into the connection "VENT" of the TC 600 (8) on the turbopump.

The venting mode of the venting valve is selected via the DCU or Serial Interface RS 485.

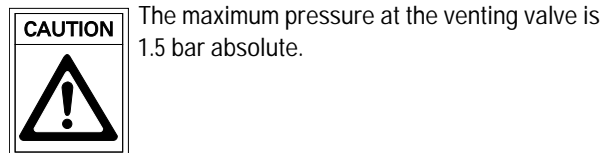
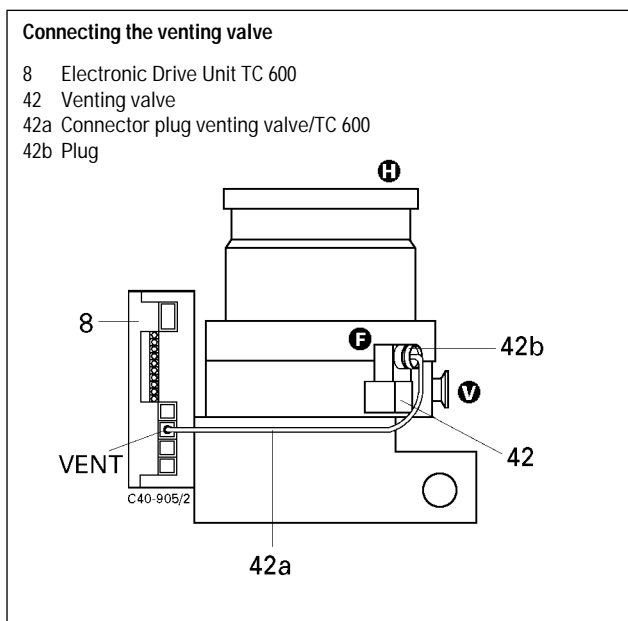

Please refer to Operating Instructions PM 800 507 BN for details on Venting Valve TVV 005.

3.6. Connecting The Casing Heating Unit

Heating turbopumps and vacuum chambers accelerates the attainment of final pressures.

The heating period is dependent on the level of contamination and the required final pressure. Heat for at least four hours.



High temperatures are generated when turbopump or vacuum chamber are baked out. Contact with hot parts can cause burns, even when the casing heating has been switched off. Heating sleeves and pump casing should be insulated when fitting.

Do not touch heating sleeves and pump casing during baking out.

Please refer to Operating Instructions PM 800 542 BN for details on the casing heating unit and its installation.

3.7. Connecting The Sealing Gas Valve

To protect the pump, particularly where corrosive or dust producing processes are involved, it is necessary to use sealing gas. Connection is made via the sealing gas valve (please see "Accessories").

Please refer to Section 9.1. "Dimensions Diagram" for the sealing gas connection.

Please refer to Operating Instructions PM 800 229 BN for details on installing the sealing gas valve and adjusting the sealing gas flow.

3.8. Installing The Power Unit



Voltage may only be supplied with the PFEIFFER power units. These power units guarantee voltage which is safely separated from the mains (in accordance with Standard EN 60 742).

The use of other power units requires the express agreement of the manufacturer.

Please refer to Operating Instructions PM 800 521 BN for details on Power Unit TPS.

3.9. Connecting The Electronic Drive Unit TC 600

Please note:

The turbopump and the Electronic Drive Unit TC 600 are connected and together form a single unit. Connecting cable 8a has to be ordered separately (see "Accessories").

- ➔ Connect plug X4 on connecting cable 8a with connection X4 on the TC 600 and secure with screw 8b.
- ➔ Connect plug X2 on connecting cable 8a with Power Unit TPS /DCU ("Accessories") on connection X2.



Once operations voltage has been supplied, the TC 600 performs a self test on the supply voltage. The supply voltage for the turbopump TPH/TPU 261 C is 48 VDC ± 5% and for the TPH/TPU 521 C is 72 VDC ± 5% in accordance with EN 60 742.

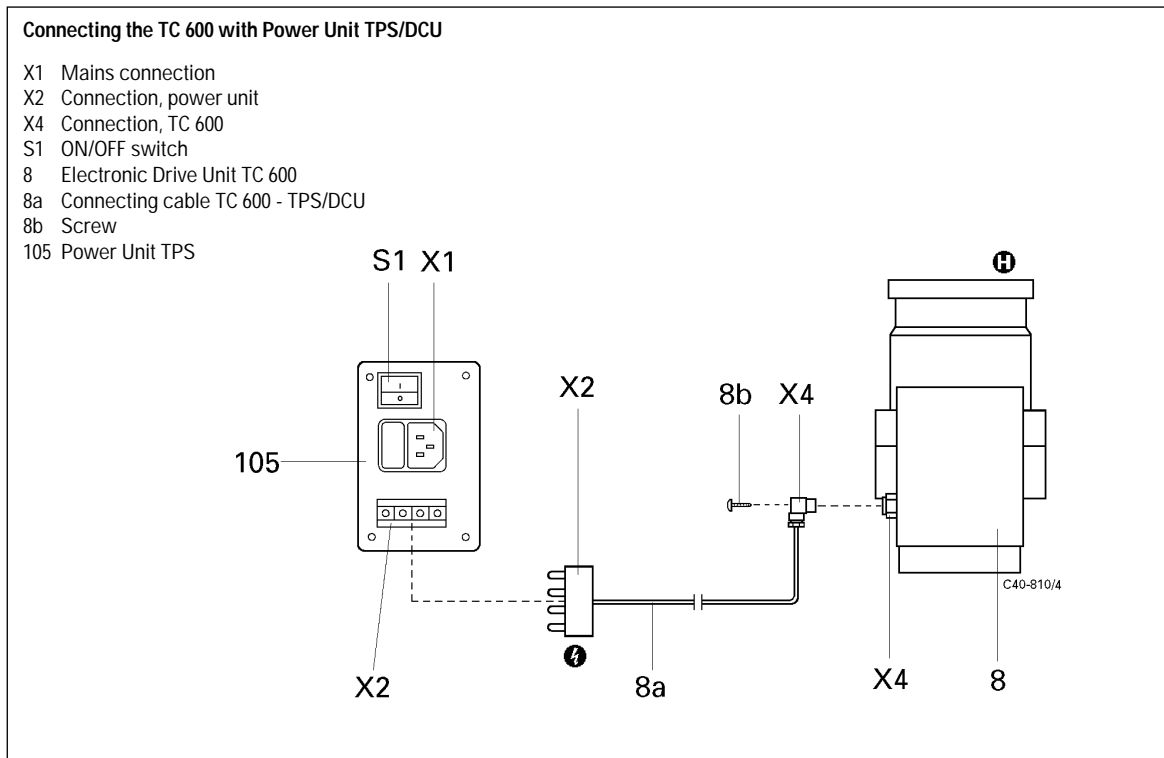

3.10. Connecting The Remote Control Unit

Remote control options for various functions are provided with the connection "REMOTE" on the TC 600 via the 10 pole screw connector plug (maximum cable cross section 0.14 - 1.5 mm²/connection).

Shielded cable should be used. Shielding has to be connected with the TC casing on the plug side of the TC 600 by using cable clamps.

The inputs 2 - 6 are activated by connecting them to the +24 V on pin 1 (active high); (please see Section 3.12. "Connections Diagram").

Pin Arrangement And Remote Plug Functions

(please see following table).



When connecting supply voltage, the turbopump is started.

On delivery:

Pin 1, Pin 2, Pin 3 and Pin 4 are bridged in the mating plug.

Pin arrangement and remote plug functions		
Pin No.	Input Open (low)	Input Closed (high) On +24 V (pin 1)
1	+24 V	
2	venting blocked (see Section 3.5.)	venting release (see Section 3.5.)
3	motor, turbopump off	motor, turbopump on: the turbopump is driven, current flows through the motor coils.
4	pumping station off	pumping station on: the turbopump is driven, backing pump is activated.
5	heating off	heating on: the heating is switched on once the rotation speed switchpoint is attained and off when the rotation speed switchpoint is unattained.
5		Reset: by supplying a pulse (T < 2s) with an amplitude of 24 V a malfunction acknowledgement can be processed.
6	standby off	standby on: pump is accelerated to 66% of its nominal rotation speed.
7	rotation speed setting mode off	the rotation speed can be changed by feeding a PWM signal to this pin or via Serial Interface RS 485 (see Section 4.8. "Rotation Speed Setting Mode").
8	Output (low) rotation speed switchpoint not attained	Output (high) set rotation speed switchpoint attained: output can be loaded with 24 V/50 mA.
9	Output (low) collective malfunction message	Output (high) malfunction-free operations; output can be loaded with 24 V/50 mA.
10	Mass (ground)	-----

3.11. Connecting The Serial Interface RS 485

An external operating component (DCU) or an external computer can be connected via the connection "RS 485" on the TC 600 with the use of an 8 pole modular connecting cable.

The serial interface is galvanically and safely separated from the maximum supply voltage from the TC 600.

Connection

Description	Value
Serial Interface Type:	RS 485
Baudrate:	9600 baud
data word lengths:	8 bit
Parity:	no (no parity)
Startbits:	1
Stopbits:	1..2

The electrical connections are internally optically decoupled at TC 600.

Pin	Arrangement
1	not connected
2	+24 V output (≤ 210 mA loading capacity)
3	not connected
4	not connected
5	RS 485: D+ (DO / RI)
6	Gnd
7	RS 485: D- (\overline{DO} / \overline{RI})
8	not connected

Please note:

It is possible to connect an RS 232 (e.g. PC) via a level converter (please see "Accessories").

RS 485

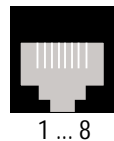

(View from the plug side of the TC 600)

Connecting The RS 485

Connecting to a fixed bus system:

- ➔ Connect all units with D+ (pin 5 / RS 485) and D- (pin 7 / RS 485) to the bus.
- ➔ The bus must be completed at both ends with R_T .

The connections should be made in accordance with the specification of the Serial Interface RS 485.

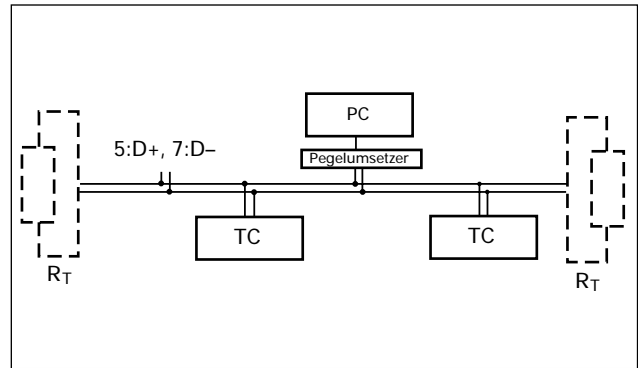

All units connected to the bus must have differing serial interface addresses (parameter 797).

The group address of the TC 600 is 960.

Only safety low voltages (SELV) may be connected to Serial Interface RS 485.



All switched on remote functions have priority over the serial interface functions.

Please Note:

Please refer to the separate Operating Instructions PM 800 488 BN for more detailed information on operations via Serial Interface RS 485 and its electronic data.

Profibus DP Gateway TIC 250 is available (accessory) for connecting an Electronic Drive Unit TC 600 to a Profibus DP. Please refer to the respective Operating Instructions PM 800 599 BN for detailed information on the operation of the TIC 250.

3.12. Connections Diagram

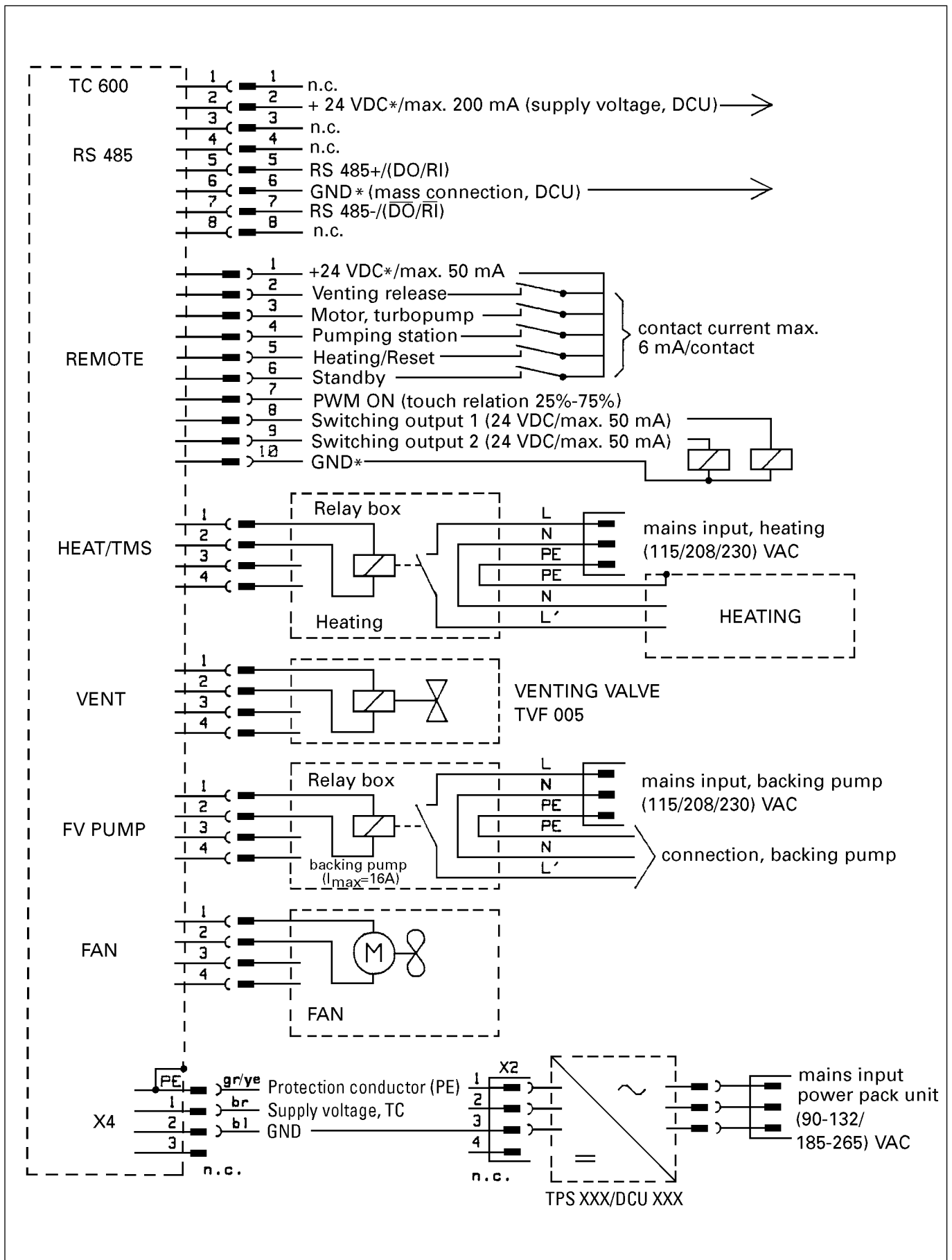

4. Operations

4.1. Filling In The Lubricant

Pumps are designed to operate with Lubricant "F3". The lubricant is not supplied with the pump and must be ordered separately (siehe 11.1.).



Pumps **must** be filled with lubricant "F3" before being operated.

The turbopumps must **not** be transported when filled with lubricant.

If possible fill in the lubricant in the fitting position of the pump.



If "F3" is heated above 300 °C, toxic vapours which can harm the airways are given off. Do not allow "F3" to come into contact with tobacco products (danger of poisoning when ignited). The precautions necessary in the handling of chemicals must be observed.

- ➔ Unscrew lubricant filler screw 71 and, using the syringe provided, inject approximately 35 cm³ of lubricant "F3".
- ➔ Screw back in lubricant filler screw with the O-ring 75.

If the pump is to be operated, the sight glass must be at least one third full of lubricant.

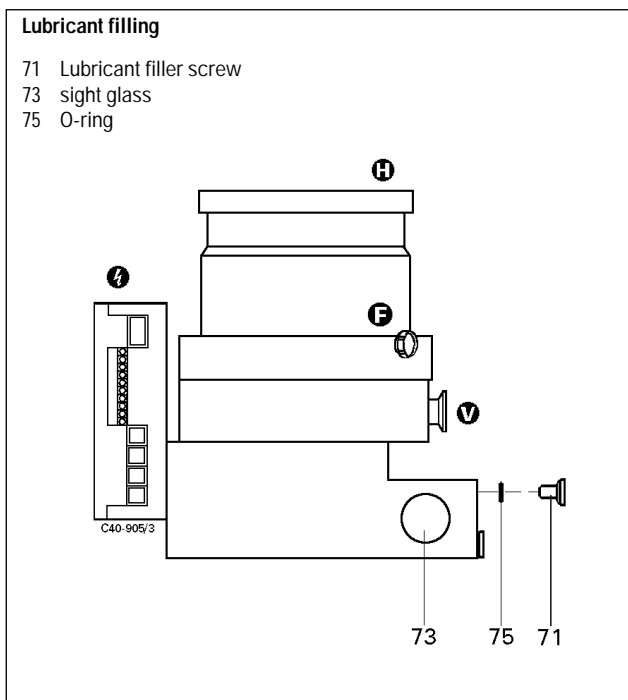

4.2. Before Switching ON

Sections 4.2. to 4.5. refer only to operating the pump in its condition on delivery, without the DCU operating unit. The bridges "venting release", "motor, TMP ON" and "pumping station ON" are fitted in the remote control plug.

Please refer to Section 4.7. regarding the switching on with the Operating And Display Control Unit DCU.



Turbopump rotors rotate at high speed. When the high vacuum flange is open there is a danger of injury and of damage to the pump caused by objects falling into the pump.

Therefore never operate the pump with open high vacuum flange.

- ➔ With sealing gas: Open the sealing gas supply.
- ➔ Open cooling water supply and check flow.
- ➔ Plug connecting cable 8a ("Accessory") into the TC 600 and connect with Power Unit TPS on X2 (please see Section 3.9.).

Please note:

The following pre-settings have been programmed:

- Start-up time 8 min
- Rotation speed switchpoint 80%
- Automatic venting 50%

These settings can only be altered via Serial Interface RS 485 (DCU or PC); please refer to the respective operating instructions.

4.3. Switching ON

- ➔ Switch on the turbopump with switch S1 on the power unit.
- Once the self test has been successfully completed on the TC 600 (duration approximately 10 seconds for TPH/TPU 261 C and 15 seconds for TPH/TPU 521 C), both the turbopump and the backing pump (if connected) begin operating.

Rear pane, Power Unit TPS 200 for the TPH/TPU 261 C

- S1 ON/OFF switch
- X1 Mains connection
- X2 Connection TC 600
- F1 Fuse
- F2 Fuse

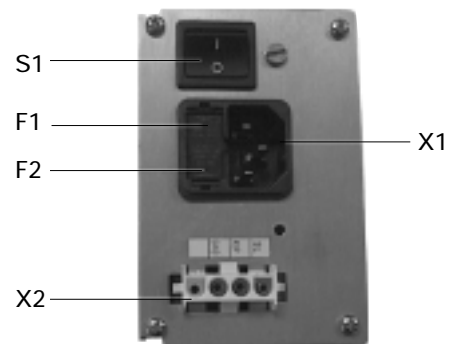

Please note:

When switching on for the first time or after a lubrication change, the flow of lubricant can be interrupted as a result of the formation of gas bubbles. In such cases, as in other malfunctions, the electronic drive unit switches off the turbopump.

- ➔ Switch off the turbopump starting switch S1 on the power unit and then on again.



Take care when pumping hazardous gases and observe the safety precautions of the gas manufacturer.

4.4. Circulatory Lubrication

The ball bearing on the fore-vacuum side is supplied with lubricant via the lubricating pump.

The circulation of the lubricant is monitored via a switching contact. If there is insufficient lubricant, the electronic drive unit switches off the turbopump. Monitoring is active only from 60% of the final rotation speed.

If, at a rotation speed of > 60% of the final rotation speed (for example through the degassification of the lubricant), the contact opens for ≥ 2 minutes, the electronic drive unit assumes a lubricant deficiency and switches off the turbopump.

- ➔ Check the filling level of the lubricant.
- ➔ Switch off the turbopump starting switch S1 on the power unit and then on again.
- ➔ Check lubricant pump function.

4.5. Switching OFF And Venting

To avoid contamination occurring when switching off, the pump should be vented before shut-down.

- ➔ Switch off both turbopump and backing pump on the power unit at the same time with switch S1.
- ➔ Open the venting screw (on delivery, screwed in) on the venting connection.
- ➔ Shut off water supply.

4.6. Shutting Down For Longer Periods



Vacuum pumps are sometimes used to pump aggressive or hazardous gases. There is a danger of personal injury resulting from coming into contact with process gases. Before removing a turbopump from the system, first:

- Vent the turbopump with a neutral gas or dry air.
- Ensure that there is no residual process gas in the system nor in the feeder lines.

If the turbopump is to be shut down for more than a year:

- ➔ Remove turbopump from the system.
- ➔ Change the lubricant (see Section 7.1.).
- ➔ Close the high vacuum flange and evacuate the turbopump via the fore-vacuum flange.
- ➔ Vent turbopump via the venting connection with nitrogen or dry air.
- ➔ Close fore-vacuum and venting connection by blank flanging.
- ➔ Place the pump vertically on its rubber feet.
- ➔ In rooms with moist or aggressive atmospheres, the turbopump must be air-sealed in a plastic bag together with a bag of dessicant, e.g. silicagel.

4.7. Operations With The DCU

Operations with the DCU 001 or DCU 200 (TPH/TPU 261 C) or DCU 300 (TPH/TPU 521 C) should be carried out in accordance with the relevant Operating Instructions PM 800 477 BN (DCU description) and PM 800 547 BN (operating the pump with the DCU).

4.8. Operations With The Remote Control Unit

(please refer to the table in Section 3.10.)

Remote control operations can be performed via the connection with the designation "REMOTE" on the TC 600.

The connection is via a 10 pole screwed connector plug with the following arrangement:

- 1 – + 24 V
- 2 – Input, venting
- 3 – Input, turbopump motor
- 4 – Input, pumping station
- 5 – Input, heating unit/reset
- 6 – Input, Standby
- 7 – Input, PWM
- 8 – Switching output 1: Rotation speed switchpoint
- 9 – Switching output 2: Collective malfunction message
- 10 – Mass

Inputs 2-6 are activated if they are connected with the +24 V on pin 1 (active high).



On delivery there is a bridge between Pin 1, Pin 2, Pin 3 and Pin 4 on the TC 600 mating plug.

When operations voltage is supplied and a successfully completed TC 600 self-test the turbopump and any connected backing pump will be started.

Venting Release (Optional)

Automatic venting:

When the turbopump or pumping station is switched off the venting valve opens for the venting time of 3600 seconds (1 hour) when the venting frequency falls below 50% of the final rotation speed (415 Hz; TPH/TPU 261 C and 357 Hz; TPH/TPU 521 C). In the event of a mains power failure if the venting frequency falls below 50% of the final rotation speed the venting valve opens and closes on attainment of 30% of the final rotation speed.

When mains power is restored the venting procedure is interrupted.

Venting OFF:

Venting does not take place.

Other venting modes:

Other venting modes can be selected via the DCU or serial interface.

Motor, Turbopump

When the pumping station is switched on and once the self test has been successfully completed (duration see Section 4.3.), the turbopump is set in operation.

During operations, the turbopump can be switched on and off while the pumping station is switched on.

Pumping Station

Any connected pumping station components are started up (e.g. backing pump, venting valve, air cooling) and with simultaneous activation of the input "motor, turbopump" the turbopump is set in operation once the self test has been successfully completed (duration see Section 4.3.).

Heating/Reset

Heating (optional)

Once the rotation speed switchpoint is attained the heating unit is switched on; when the rotation speed switchpoint is fallen below the heating unit is switched off.

Reset

The heating input has two functions (please see Section 3.10., point 5 "Reset").

Standby

The pump can be operated optionally at 66% of its nominal rotation speed (standby ON) or at its nominal rotation speed (standby OFF).

Rotation Speed Setting Operations Via Input PWM

The supply of pulse width modulated signals (PWM) with a ground frequency of $100 \text{ Hz} \pm 20\%$ with an amplitude of maximum 24 V and a touch ratio of 25-75% enables the rotation speed to be set in the range from 20-100% of the nominal rotation speed.

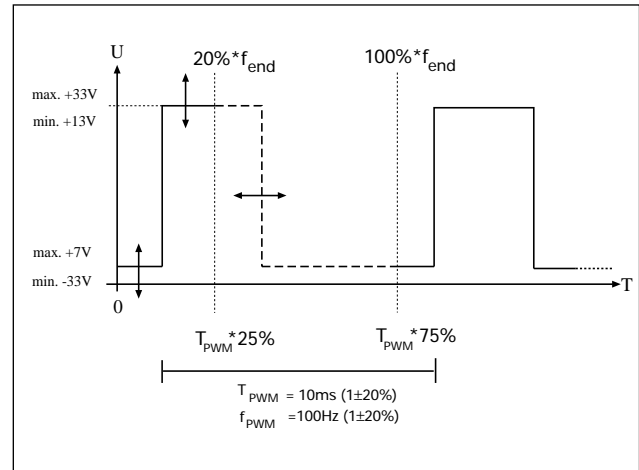

If no signal is present the pump accelerates up to its final rotation speed.

A PWM adapter box for rotation speed setting operations for the turbopump is available as an option (please see "Accessories").

Switching Outputs

Switching outputs 1 and 2 can be loaded with a maximum 24 V / 50 mA per output. The following functions are assigned to the switching outputs:

Switching output 1: Active high when the rotation speed switchpoint is attained. The switchpoint for the turbopump is set at 80% of the nominal rotation speed. It can be used, for example, for a message "pump ready to operate".

Switching output 2: Active low with a malfunction - collective malfunction message.



The connection of a relay is made between pin 10 (mass) and the respective switching output pin 8 or pin 9 (see Section 3.12. Connections Diagram).

5. Monitoring Operations

5.1. Operations Display Via LED

Certain operations modes of the turbopump and the TC 600 can be ascertained via the two integrated LEDs located on the front panel of the TC 600.

The following operations modes are displayed:

LED		Cause
		
glows green	–	– power unit OK Function "pumping station ON" carried out
flashes green		– power unit OK – Pumping station OFF
blinks green		– Mains power supply failure
	glows red	– Collective malfunction (for example, start-up time error, excess temperature, turbopump or TC 600, lubricant deficiency) – Switching output 2 active (low)
	blinks red	– Warning (for example, earth leakage fault in the voltage supply, mains power supply failure)

Please note:

Differentiated malfunction and warning signals are only possible with the use of the DCU.

5.2. Turbopump Temperature Monitoring

Where impermissible motor temperatures are involved or the temperature of the casing is too high, the motor current is reduced.

This can lead to dipping below the set rotation speed switch-point and results in the turbomolecular pump being switched off.

LED on the TC 600 glows red: Collective malfunction.

6. What To Do In Case Of Breakdowns?

Problem	Possible Causes	Remedy
Pump doesn't start; None of the integrated LEDs glow on the TC 600	<ul style="list-style-type: none"> • Power supply interrupted • Incorrect operations voltage supplied • Pins 1-3 and 1- 4 on the remote-plug not connected • No supply of operations voltage • Defect TC 600 • Reduction in the voltage in the cable • Lubricating pump dirty 	<ul style="list-style-type: none"> • Check fuse in the power unit • Check plug contacts on the power unit • Check power unit feeder line • Check voltage on the power pack unit (TPH/TPU 261 C - 48 VDC; TPH/TPU 521 C - 72 VDC) at connection X2 • Supply correct operations voltage • Connect pins 1-3 and 1- 4 on the remote plug • Check plug contacts on the power unit • Inform PFEIFFER Service of need for repair • Use suitable cable • Clean the lubricating pump as per Section 7.2.
Pump doesn't attain nominal rotation speed within the set start-up time; Pump cuts out during operations	<ul style="list-style-type: none"> • Fore-vacuum pressure too high • Leak or too high levels of gas load • Rotor sluggish caused by defective bearing • TC start-up time too short • Thermal overloading caused by: <ul style="list-style-type: none"> – Insufficient water flow – Insufficient air supply – Fore-vacuum pressure too high – Ambient temperature too high • Lubricant or lubricating pump dirty • Lubricant deficiency 	<ul style="list-style-type: none"> • Check backing pump function • Check seals • Seek leak and repair • Supply of process gas too high; reduce • Check bearing (noises?): Request PFEIFFER Service to replace • Set longer start-up time with the DCU or PC • Ensure free flow • Ensure adequate air supply • Reduce fore-vacuum pressure • Reduce ambient temperature • Carry out lubricant change as per Section 7.1. or clean the lubricating pump as per Section 7.2. • Check lubricant and replace as necessary
Pump doesn't attain final pressure	<ul style="list-style-type: none"> • Pump dirty • Leak in vacuum chamber, lines or pump 	<ul style="list-style-type: none"> • Bake out pump • If seriously contaminated: Request PFEIFFER Service to clean • Seek leak starting with vacuum chamber • Repair leak
Unusual operating noises	<ul style="list-style-type: none"> • Bearing damaged • Rotor damaged • Splinter shield (if fitted) not seated firmly 	<ul style="list-style-type: none"> • Inform PFEIFFER Service of need for repair • Inform PFEIFFER Service of need for repair • Check seat of splinter shield (see Section 3.2.)
Red LED on the TC 600 glows	<ul style="list-style-type: none"> • Collective malfunction 	<ul style="list-style-type: none"> • Reset via mains OFF/ON or remote pin 5 • Different malfunction display with a DCU possible
Red LED on the TC 600 blinks	<ul style="list-style-type: none"> • Warning from: <ul style="list-style-type: none"> – Mains power failure – Supply voltage short circuit to earth 	<ul style="list-style-type: none"> • Different warning display with a DCU is possible • Check power pack voltage • Check the power pack mains connection • Check the power unit voltage for short circuit to earth

7. Maintenance

Important

No liability for personal injury nor material damage will be accepted for damages and operational interruptions which have been caused by improper maintenance; in addition, all guarantees become invalid.

- You can change the lubricant yourself. Your pump can be cleaned on the spot if it is not very dirty. (see Section 7.1. und 7.2.).
- Your pump can be cleaned on the spot if is not very dirty. Your local PFEIFFER Service can advise your regarding cleaning procedures and any other maintenance and service work.



Ensure no mechanical forces act on the Electronic Drive Unit TC 600.

7.1. Replacing The Lubricant

The lubricant should be replaced at least once a year. Where extreme operating conditions or unclean processes are involved, the replacement interval should be checked with your PFEIFFER Service Center.



Drain of and fill in the lubricant in the fitting position if possible. If it is absolutely necessary to dismantle the pump to change the lubricant, this may only be carried out in the position shown in Section 3.2. otherwise the lubricant could contaminate the pump.

- ➔ Switch off the turbopump, vent to atmospheric pressure (see Section 4.5.) and allow to cool as necessary.
- ➔ If necessary, remove the turbopump from the system.
- ➔ Unscrew lubricant drain screw and drain lubricant into a suitable container.
- ➔ Screw back in lubricant drain screw with the O-ring.
- ➔ Unscrew lubricant filler screw. Using the syringe provided inject approximately 35 cm³ of lubricant "F3" (please see Section 4.1. for the lubricant level).
- ➔ Screw in lubricant filler screw with the O-ring.



Lubricants can contain toxic substances from the medium pumped. Lubricant must be disposed of in accordance with the respective regulations.

Safety instructions data sheet on request.

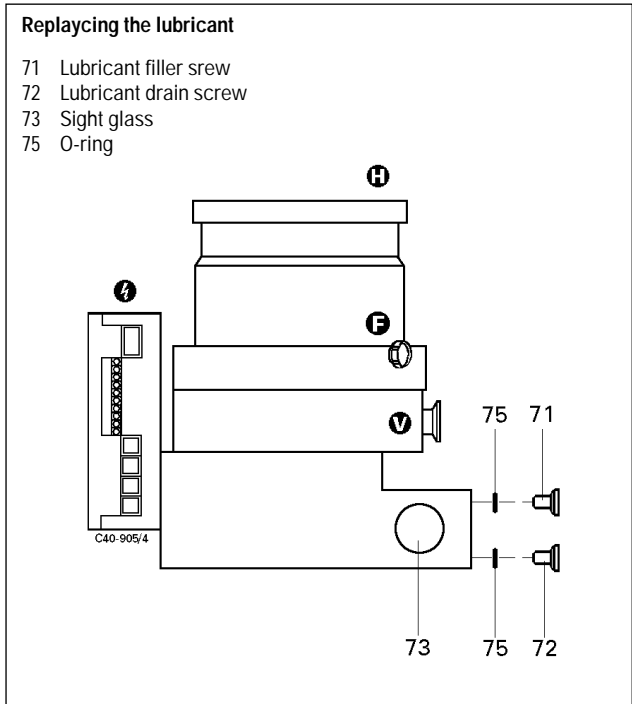

7.2. Cleaning The Lubricating Pump

If, following a malfunction, the pump does not accelerate to its operational rotation speed on account of insufficient lubricant, the lubricating pump must be cleaned.

➔ Drain lubricant and dispose of as described in Section 7.1..

Detach the lubricating pump as follows and drain the remaining lubricant:

- ➔ Unscrew the two screws 82, screw in two M5 forcing screws to press lubricant pump out of the upper part and lift out.
- ➔ Clean the lubricating pump 77 and boring in the lubricant reservoir using a clean, fluff-free cloth and pure alcohol.
- ➔ Dismantle the lubricating pump in accordance with the following diagram and clean with pure alcohol.
- ➔ Force out pin 80 in order to remove floater 79. When re-fitting, the floater head should point to the pin.

- ➔ Re-assemble lubricating pump; take care with O-ring 74.
- ➔ Screw in lubricant drain screw 72 with O-ring 75.
- ➔ Fill in approximately 40 cm³ (after cleaning) of lubricant in accordance with Section 4.1..

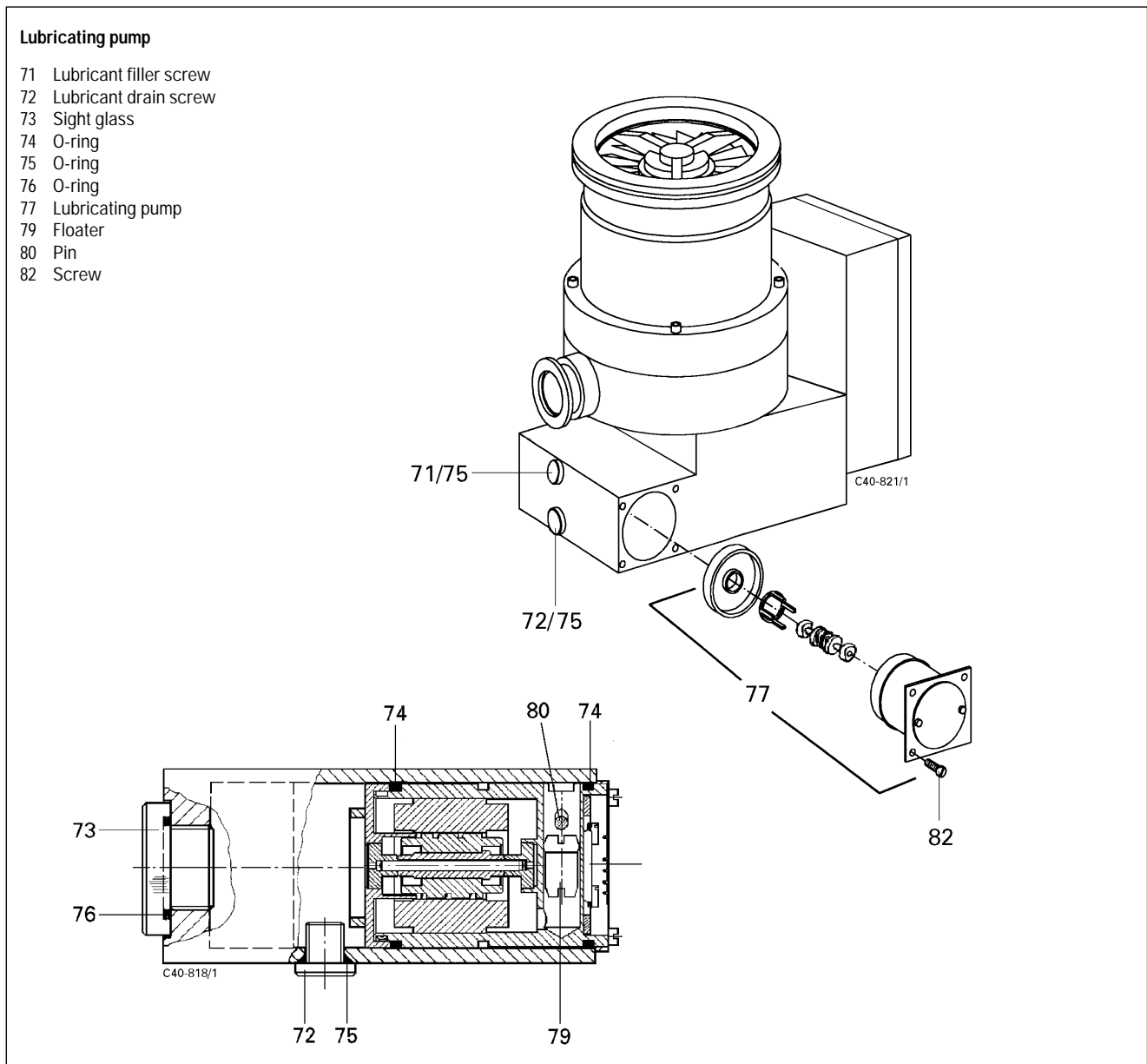

8. Service

Do make use of our service facilities

In the event that repairs are necessary a number of options are available to you to ensure any system down time is kept to a minimum:

- Have the pump repaired on the spot by our PFEIFFER Service Engineers;
- Return the pump to the manufacturer for repairs;
- Replace the pump.



Please take into account that where PFEIFFER Service replacement service is involved the standard operating parameters are always pre-set.

If your application requires different parameters, please modify accordingly.

Local PFEIFFER representatives can provide full details.

Please note:

The turbopump and the Electronic Drive Unit TC 600 form a single unit and must therefore be returned complete for repair purposes. Before returning the unit it should be ensured that the power unit is not the cause of the malfunction (please see Section 5. for checking the power unit).

Before returning:

- ➔ Please attach a clearly visible notice "Free of harmful substances" (both on the unit and also on the delivery note and any accompanying letters).

"Harmful substances" are substances and preparations as defined in the current, local, dangerous substances regulations; in the U.S.A. as "materials in accordance with the Code of Federal Regulations (CFR) 49 Part 173.240 Definition and Preparation". We will carry out the decontamination and invoice this work to you if you have not attached this note.

This also applies where the operator does not have the facilities to carry out the decontamination work.

Fill out the declaration of contamination

- ➔ In every case the "Declaration of Contamination" must be completed diligently and truthfully.
- ➔ A copy of the completed declaration must accompany the unit; any additional copies must be sent to your local PFEIFFER Service Center.

Please get in touch with your local PFEIFFER representatives if there are any questions regarding contamination.



Decontaminate units before returning or possible disposal. Do not return any units which are microbiologically, explosively or radioactively contaminated.

Returning contaminated units

If contaminated have to be returned for maintenance/repair, the following instructions concerning shipping must be followed:

- ➔ Neutralise the pump by flushing with nitrogen or dry air.
- ➔ Seal all openings to the air.
- ➔ Seal pump or unit in suitable protective foil.
- ➔ Ship units only in appropriate transport containers.

Please note:

Repair orders are carried out according to our general conditions of sale and supply. If repairs are necessary, please send the pump to your nearest PFEIFFER Service Center.

Contact addresses and telephone hotline

Contact addresses and telephone numbers can be found on the back cover of these operating instructions.

9. Technical Data

Feature	Unit	TPH 261 C TPU 261 C	TPH 521 C TPU 521 C	TPH 521 C TPU 521 C
Connection nominal diameter:: Inlet		DN 100 ISO-K DN 100 CF-F	DN 100 ISO-K DN 100 CF-F	DN 160 ISO-K DN 160 CF-F
Outlet		DN 25 ISO-KF/G 1/4"	DN 25 ISO-KF/G 1/4"	
Nominal rotation speed	1/min	50 000	43 000	
Standby rotation speed	1/min	33 000	28 600	
Start-up-time	min	2	5.5	
Noise level	dB (A)	< 50	< 50	
Final pressure, backing pump	mbar	< 10 ⁻²	< 10 ⁻²	
Maximum permissible rotor temperature	°C	120	120	
Permissible heat radiaten power	W	8	14	
Volum flow rate for:				
Nitrogen N ₂	l/s	190	260	430
Argon Ar	l/s	180	250	430
Tetraflourmethan CF ₄	l/s	160	220	360
Compression ration for:				
N ₂		> 10 ⁷	> 10 ⁷	> 10 ⁷
Ar		> 10 ⁷	> 10 ⁷	> 10 ⁷
CF ₄		> 10 ⁷	> 10 ⁷	> 10 ⁷
Maximum fore-vacuum pressure				
N ₂	mbar	1	0.8	
Ar	mbar	1	1.2	
CF ₄	mbar	1	1.2	
Gas throughput ¹⁾				
with water cooling				
N ₂	mbar l/s	3.5	8	
Ar	mbar l/s	4.0	7	
CF ₄	mbar l/s	5.5	7	
Final pressure ²⁾				
with rotary vane vacuum pump	mbar	1 · 10 ⁻⁹	1 · 10 ⁻⁹	
Lubricant		F3	F3	
Maximum cooling water consumption with water at 15 °C ³⁾	l/h	100	100	
Cooling water temperature	°C	5 - 25	5 - 25	
Permissible ambient temperature with air cooling	°C	0 - 35	0 - 35	
Power consumption, casing heating unit	W	60	100	
Weight	kg	6/6.5	13/13.4	13.5/13.9
Permissible magnetic field	mT	5.5	5.0	
Operating voltage	VDC	48 ± 5%	72 ± 5%	
Duration ³⁾ - / max. current consumption	A	4.1 / 4.6	3.2/4.2	
Duration ³⁾ - / max. power	W	200 / 220	230/300	
Protection class		IP 30	IP 30	

1) Measured with the Rotary vane Vacuum Pump DUO 10 at the TPH/TPU 261 C and DUO 030 A at the TPH/TPU 521 C. The stated gas throughput values are applicable for a high vacuum pressure of 0.1 mbar.

2) In accordance with DIN 28 428 the final pressure is that pressure which is attained in a measuring dome 48 hours after backing out.

3) With maximum gas throughput.

9.1. Dimensions Diagram

TPH/TPU 521 C

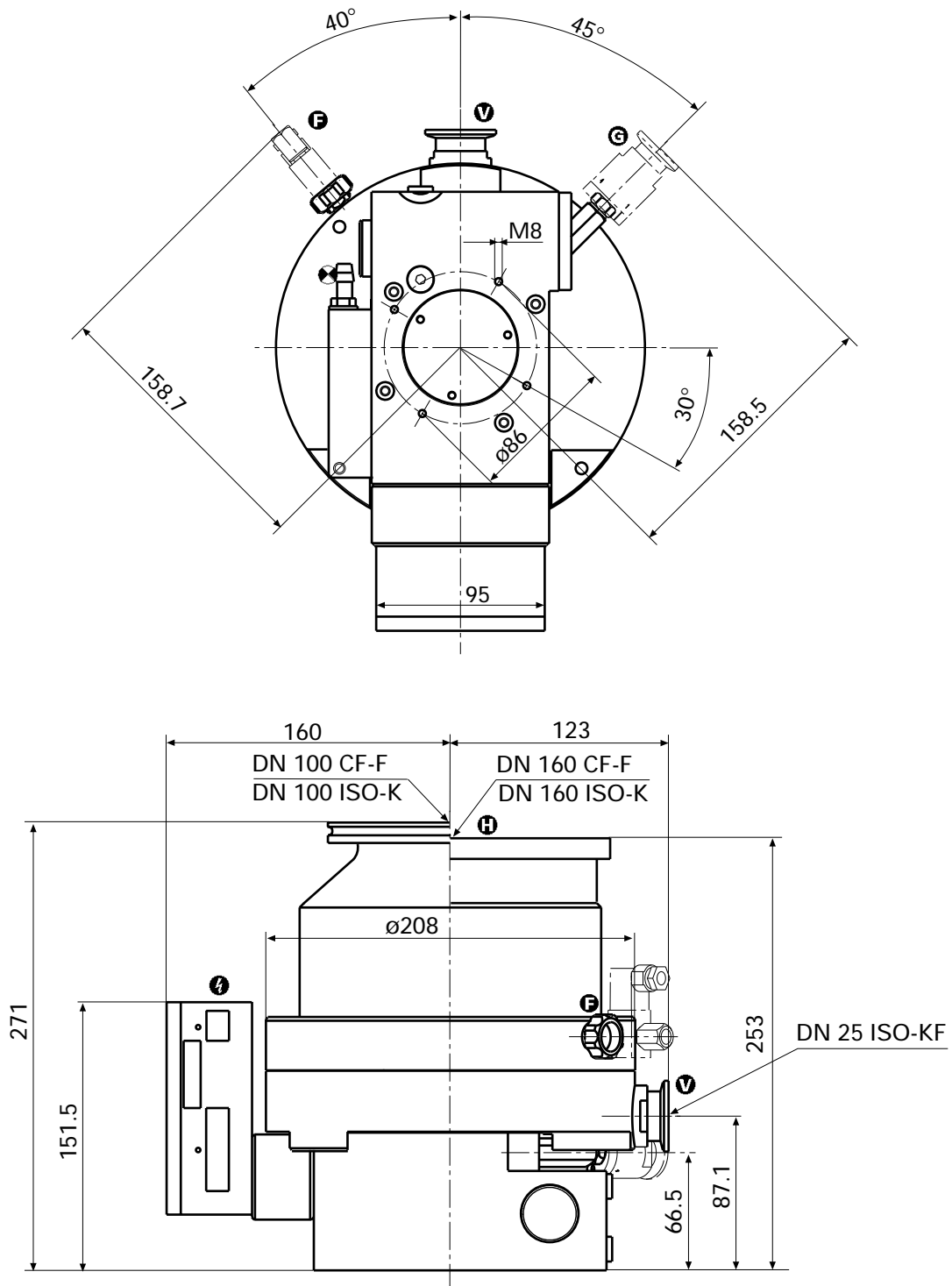

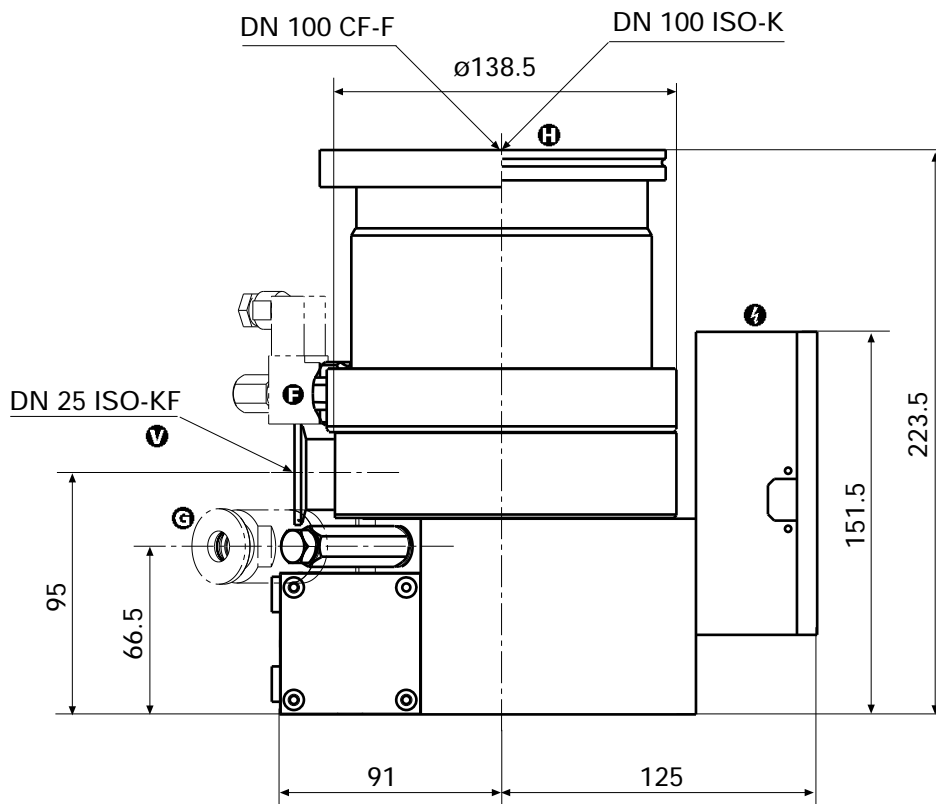
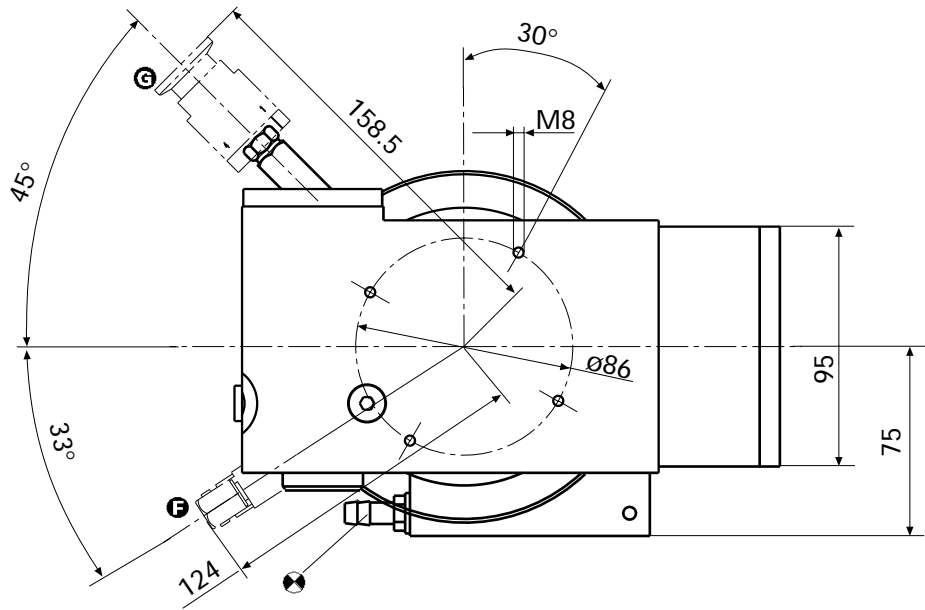

Description	Size	Number	Comments/ Operating Instructions	Order Quantity
Collar flange with retaining ring, TPH CU seal (10 St.), TPU Set of screws, TPU Sealing gas valve Hose nipple for sealing gas valve	DN 100 ISO-F DN 160 ISO-F DN 100 CF DN 160 CF DN 100 CF DN 160 CF DN 16 ISO-KF-10	PF 307 110 -T PF 307 116 -T PF 501 410 -T PF 501 416 -T PF 505 003 -T PF 505 003 -T PM Z01 142 PF 144 020	PM 800 229 BN	

10.1.Lubricant

Lubricant	Amount	Order Number	Order Quantity
"F3"	0.05 l	PM 006 336 -T	
"F3"	0.25 l	PM 006 313 -T	

11. Spare Parts

Pos.	Description	Pieces	Size	Number	Comments	Order Quantity
	Spare parts TPH/TPU 261 C and TPH/TPU 521 C					
	Set of seals TPH/TPU 261 C	1		PM 043 500 -T		
	TPH/TPU 521 C	1		PM 063 984 -T		
6	Rubber foot	4		P 3695 700 ZE		
17	USIT-ring	1		P 3529 133 -A		
71	Lubricant filler screw	1	A2-50, G1/8" A	N 3191 382 X		
72	Lubricant drain screw	1	A2-50, G1/8" A	N 3191 382 X		
73	Sight glass	1		PM 003 251		
74	O-ring	2	Vi 36 x 2	P 4070 594 PV		
75	O-ring	2	Vi 6 x 2.2	P 4070 088 PV		
76	O-ring	1	Vi 22 x 3	P 4070 384 PV		
77	Lubricating pump: complete	1		PM 083 449 -T		
79	Floater	1		PM 033 306 -X		
81	Centering ring	1	Al, Neopren DN 25 ISO-KF	PF 110 025 -T		

When ordering accessories and spare parts please be sure to state the full part number. When ordering spare parts please state additionally the unit type and unit number (see rating plate). Please use this list as an order form (by taking a copy).

Spare parts

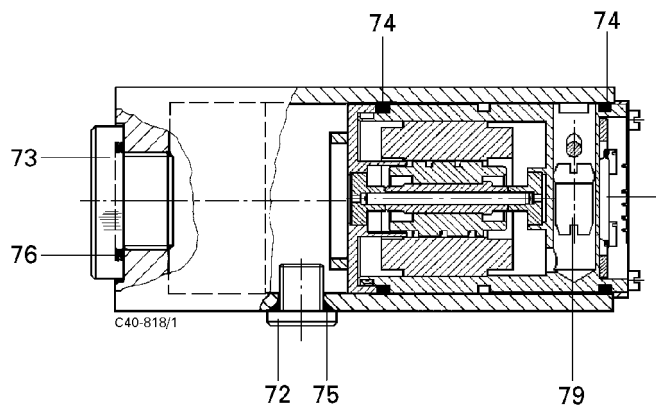
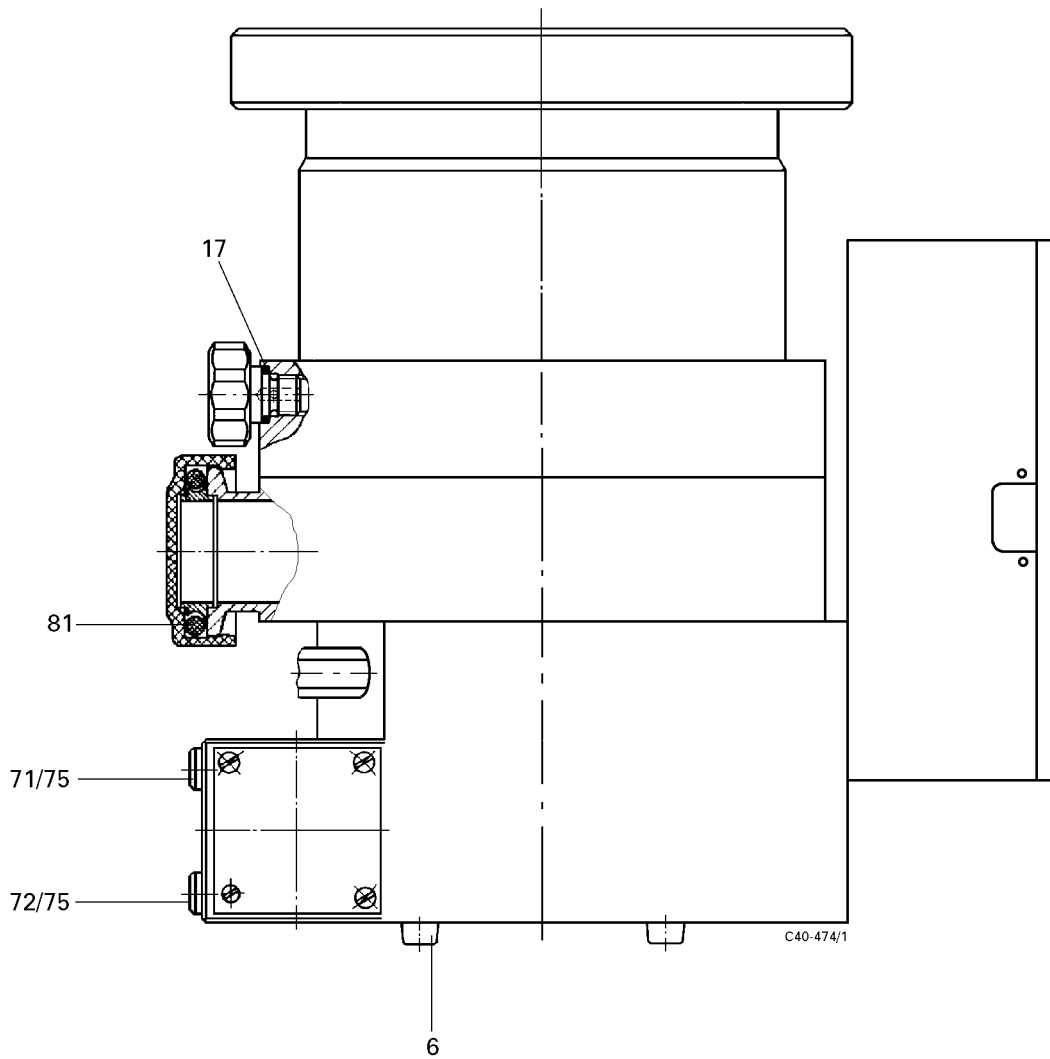

Drawings

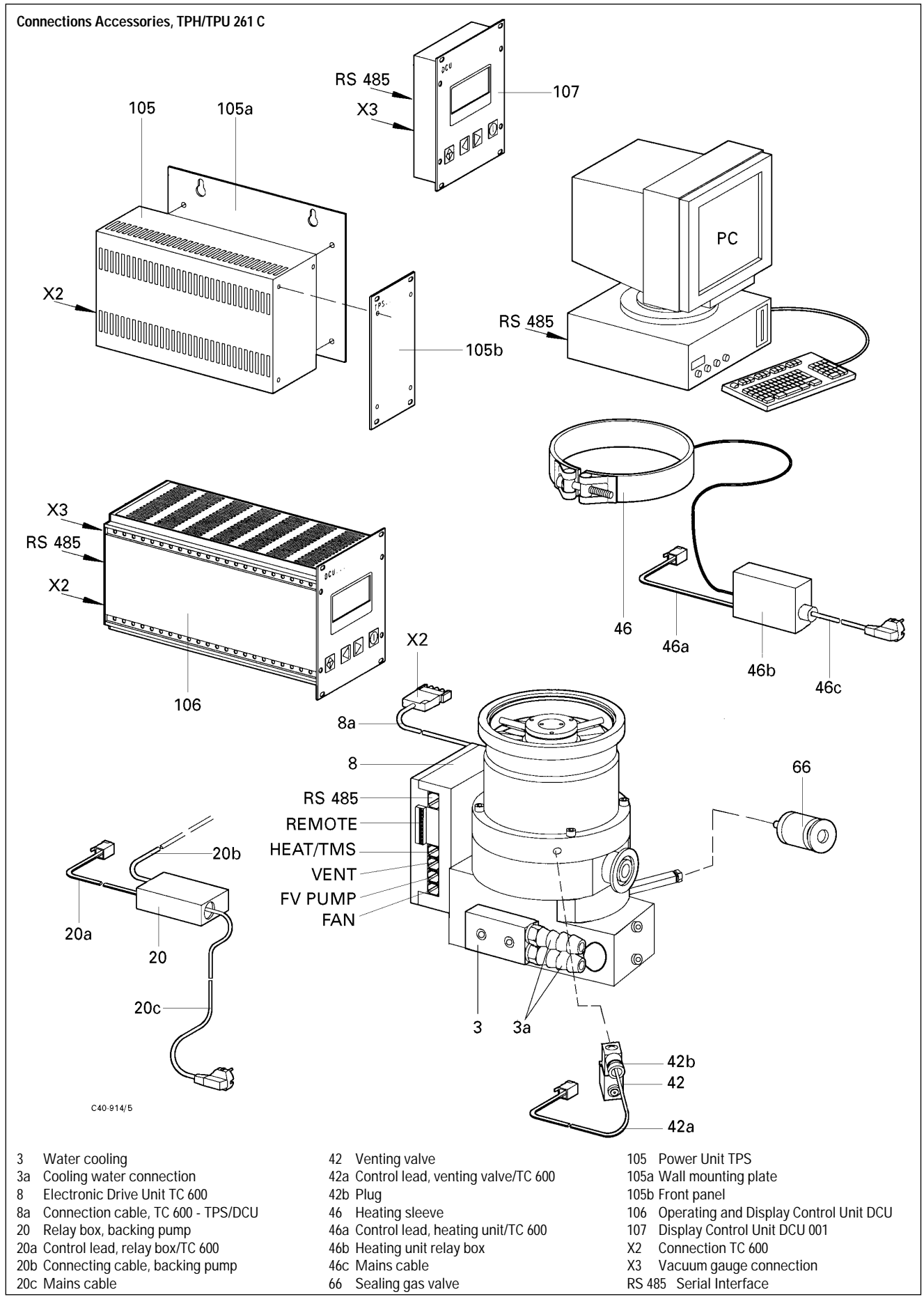

Declaration of Contamination of Vacuum Equipment and Components

The repair and/or service of vacuum components will only be carried out if a correctly completed declaration has been submitted. Non-completion will result in delay.

The manufacturer could refuse to accept any equipment without a declaration.

This declaration can only be completed and signed by authorised and qualified staff:

1. Description of component:

- Equipment type/model: _____
- Code No.: _____
- Serial No.: _____
- Invoice No.: _____
- Delivery Date: _____

2. Reason for return:

3. Equipment condition

- Has the equipment been used?
yes no
- What type of pump oil was used?

- Is the equipment free from potentially harmful substances?
yes (go to section 5)
no (go to section 4)

4. Process related contamination of equipment

- toxic yes no
- corrosive yes no
- microbiological hazard*) yes no
- explosive*) yes no
- radioactive*) yes no
- other harmful substances yes no

*) We will not accept delivery of any equipment that has been radioactively or microbiologically contaminated without written evidence of decontamination!

Please list all substances, gases and by-products which may have come into contact with the equipment:

Tradename Product name Manufacturer	Chemical name (or Symbol)	Danger class	Precautions associated with substance	Action if spillage or human contact
1.				
2.				
3.				
4.				
5.				

5. Legally Binding Declaration

I hereby declare that the information supplied on this form is complete and accurate. The despatch of equipment will be in accordance with the appropriate regulations covering Packaging, Transportation and Labelling of Dangerous Substances.

Name of Organisation: _____

Address: _____ Post code: _____

Tel.: _____

Fax: _____ Telex: _____

Name: _____

Job title: _____

Date: _____ Company stamp: _____

Legally binding signature: _____

Herstellererklärung *Manufacturer's Declaration*

im Sinne folgender EU-Richtlinien:
pursuant to the following EU directives:

- Maschinen/*Machinery* 98/37/EG
- Elektromagnetische Verträglichkeit/*Electromagnetic Compatibility* 89/336/EWG
- Niederspannung/*Low Voltage* 73/23/EWG

Hiermit erklären wir, daß das unten aufgeführte Produkt zum Einbau in eine Maschine bestimmt ist und daß deren Inbetriebnahme so lange untersagt ist, bis festgestellt wurde, daß das Endprodukt den Bestimmungen der EU-Richtlinie 98/37/EG, Anhang II B entspricht.

Wir bestätigen Konformität mit der EU-Richtlinie über elektromagnetische Verträglichkeit 89/336/EWG und der EU-Niederspannungsrichtlinie 73/23/EWG.

We hereby certify that the product specified below is intended for installation in a machine which is forbidden to be put into operation until such time as it has been determined that the end product is in accordance with the provision of EU Directive 98/37/EEC, Annex II B.

We certify conformity with EU Electromagnetic Compatibility Directive 89/336/EEC and EU Low Voltage Directive 73/23/EEC.

Produkt/*Product:*

TPH 261 C / TPU 261 C

TPH 521 C / TPU 521 C

Angewendete Richtlinien, harmonisierte Normen und angewendete, nationale Normen:

Guidelines, harmonised standards, national standards in which have been applied:

EN 292-1, EN 292-2, EN 294,
EN 1012-2, EN 61010

Unterschrift/*Signature:*



Pfeiffer-Vacuum GmbH
Emmeliusstrasse 33
35614 Asslar
Germany

(W. Dondorf)
Geschäftsführer
Managing Director

Zentrale/Headquarters

Pfeiffer Vacuum GmbH
Emmeliusstrasse 33
D-35614 Asslar
Telefon 06441/802-0
Telefax 06441/802-202
Hotline 06441/802-333
Internet:
<http://www.pfeiffer-vacuum.de>

Argentina

ARO S.A., Casilla de Correo 4890,
1000 Buenos Aires, telephone +54 / 1 331 3918,
telefax +54 / 1 331 3572

Australia

Balzers Australia Pty. Ltd., Level 1,
3, Northcliff Street, Milsons Point, NSW 2061,
telephone +61 / 2 9954 1925, telefax +61 / 2 9954 1939

Austria

Pfeiffer Vacuum Austria GmbH
Diefenbachgasse 35, A-1150 Wien,
telephone +43 / 1 8941 704, telefax +43 / 1 8941 707
Service Hotline: +43 / 1 8941704

Branch Office, Czech Republic

Pfeiffer Vacuum Austria GmbH, Branch Prague
Zvonarska 885
CZ-156 00 Praha 5
telephone + 420/2 900 42981
telefax + 420/2 579 23014

Belgium / Luxemburg

Pfeiffer Vacuum Belgium N.V./S.A.
Luxemburgstraat 5, B-1940 Temse
telephone +32 / 3 710 5920, telefax +32 / 3 710 5929
Service Hotline: +32 / 3 710 5922

Brazil

Elmi Tec
Assistencia Técnica e Representação S/C Ltda.
Rua Bernadino de Compos, 551
CEP 04620-002 São Paulo, SP - Brasil
telephone +55 / 11 532 0740
telefax +55 / 11 535 3598

Chile

BERMAT S.A., Coyancura 2283, piso 6
Providencia, P.O. Box 9781, Santiago
telephone +56 / 2 231 8877,
telefax +56 / 2 231 4294

Colombia

Arotec Colombiana S.A., Carrera 15 No.38-17
P.O. Box 050 862, Santafé de Bogotá / D.C.
telephone +57 / 1 288 7799, telefax +57 / 1 285 3604

Denmark

Pfeiffer Vacuum Scandinavia AB, Vesterengen 2,
DK-2630 Taastrup,
telephone +45 / 43 52 38 00
telefax +45 / 43 52 38 50

France

Pfeiffer Vacuum France SAS
45, rue Senouque, BP 139 F-78531 BUC Cedex
telephone +33 / (0)1 30 83 04 00
telefax +33 / (0)1 30 83 04 04

Germany

Pfeiffer Vacuum GmbH,
Emmeliusstrasse 33, D-35614 Asslar
telephone +49 / 6441 802 400
telefax +49 / 6441 802 399
Service Hotline: +49 / 6441 802 333

Great Britain

Pfeiffer Vacuum Ltd.
Bradbourne Drive, Tilbrook,
Milton Keynes, MK7 8AZ, United Kingdom
telephone +44 / 1 908 373 333
telefax +44 / 1 908 377 776

Greece

Analytical Instruments S.A., 1 Mantzarou St.,
GR-15451 Athens,
telephone +30 / 1 674 8973
telefax +30 / 1 674 8978

India

Pfeiffer Vacuum India Ltd.
25-E Nicholson Road, Tarbund
Secunderabad 500 009,
telephone +91 / 40 775 0014, telefax +91 / 40 775 7774

Israel

ODEM Scientific Applications,
2 Bergman Street, Science based park
Rehovod
telephone +972 8 9366 101,
telefax +972 8 9366 102

Italy

Pfeiffer Vacuum Italia S.p.a.
Via San Martino, 44 I-20017 RHO (Milano)
telephone +39 / 2 93 99 051, telefax +39 / 2 93 99 05 33

Japan

Hakuto Co. Ltd., C.P.O. Box 25,
Vacuum & Scientific Instruments Division
Tokyo Central 100-91,
telephone +81 / 3 32 258 910
telefax +81 / 3 32 259 009

Korea

Pfeiffer Vacuum Korea Ltd., 3F Haein Building 453,
Dokok-Dong, Kang Nam-Ku, Seoul, 135-270
telephone +82 / 2 3461 0671/5
telefax +82 / 2 3461 0676

Netherlands

Pfeiffer Vacuum Nederland BV
Veldzigt 30a, NL-3454 PW De Meern,
telephone +31 / 30 6666050, telefax +31 / 30 6662794

Peru

Ing. E. Brammertz S.C.R.L., José Pardo 182,
Apartado 173, PE-18 Miraflores,
telephone +51 / 1 445 8178
telefax +51 / 1 445-1931

Poland

Softtrade Sp.z.o.o, ul. Malwowa 35,
PL-60-175 Poznan, telephone +48 / 61 8677 168,
telefax +48 / 61 8677 111

Portugal

Unilaser Lda, Taguspark
Núcleo Central, sala nº 268, Estrada Cacém-
Porto Salvo, P-2780 Oeiras
telephone +351 / 1 421 7733
telefax +351 / 1 421 7744

Singapore

APP Systems Services Pte. Ltd, 2 Corporation Road
06-14 Corporation Place, Singapore 618494,
telephone +65 / 268 2024, telefax +65 / 268 6621

Spain

Tecnovac
Tecnología de Vacío S.L., Ronda de Poniente, 6 Bajo F
Centro Empresarial Euronova
E-28760 Tres Cantos (Madrid)
telephone +34 / 91 804 11 34,
telefax +34 / 91 804 30 91

Sweden

Pfeiffer Vacuum Scandinavia AB
Johanneslundsvägen 3
S-194 61 Upplands Väsby
telephone +46 / 590 748 10
telefax +46 / 590 748 88

Switzerland

Pfeiffer Vacuum Schweiz S.A.
Förllibuckstraße 30, CH-8005 Zürich
telephone +41 / 1 444 2255,
telefax +41 / 1 444 2266

South Africa

Labotec Pty Ltd., P.O. Box 6553,
Halfway House
1685 Midrand
telephone +27 / 11 315 5434
telefax +27 / 11 315 5882

Taiwan

S & T Hitech Ltd. Hsinchu office
No. 103, Hsien Chen 11th Street, Jubei City,
HsinChu County, Taiwan, R.O.C.
(zip/postal code: 302)
telephone +886 / 3 554 1020
telefax +886 / 3 554 0867

Thailand

S & T Enterprises (Thailand) Ltd.
18th Floor, Chokchai Int'l Bldg.
690 Sukhumvit Road
Klongton, Klongtoey
Bangkok 10110
telephone +662 / 259 4623
telefax +662 / 259 6243

U.S.A.

Pfeiffer Vacuum, Inc.
24 Trafalgar Square
Nashua, NH 03063-1988
USA
telephone +1/ 603 578 6500
telefax +1/ 603 578 6550

Venezuela

Secotec S.A., Apartado 3452, Caracas 1010-A,
telephone +58 / 2 573 8687
telefax +58 / 2 573 1932

Other countries

AVI - Applied Vacuum Industries GmbH
Leginglenstrasse 17A; CH-7320 Sargans
Switzerland
telephone +41 / 81 710 03 80
telefax +41 / 81 710 03 81

Scope of represented countries

Armenia, Azerbaijan, Bangladesh, Belarus, Bulgaria,
Cambodia, Estonia, Georgia, Hong Kong, Kazakhstan,
Kingdom of Nepal, Kirghizia, Latvia, Lithuania,
Maldavia, Philippines, P.R. China, Rumania, Russia,
Tajikistan, Turkmenistan, Ukraine, Uzbekistan, Vietnam

A.E.M.S.

Advanced Equipment Materials and Systems
P.O. Box 25
Föhrenweg 18
FL-9496 Balzers
telephone +41 / 75 380 0550
telefax +41 / 75 380 0551

Scope of represented countries

Bahrain, Egypt, Iraq, Iran, Jordan, Kuwait, Lebanon,
Lybia, Oman, Pakistan, Saudi-Arabia, Sudan, Syria,
Turkey, United Arab Emirates, Yemen