

ASM 340

Leak detector

# Maintenance instructions

# Table of contents

<b>1</b>	<b>About this manual</b>	<b>4</b>
1.1	Validity	4
1.1.1	Applicable documents	4
1.2	Conventions	5
1.2.1	Safety instructions	5
1.2.2	Pictographs	6
1.2.3	Instructions in the text	6
1.2.4	Abbreviations used	6
1.2.5	Labels	6
<b>2</b>	<b>Safety and maintenance information</b>	<b>7</b>
2.1	Safety precautions	7
2.2	Protective equipment	8
2.3	Maintenance preparation	8
2.4	Tools and spare parts	9
<b>3</b>	<b>Maintenance intervals and responsibilities</b>	<b>10</b>
3.1	Maintenance time monitoring	11
<b>4</b>	<b>Calibration</b>	<b>12</b>
4.1	Purpose	12
4.2	Calibration with the internal calibrated leak	12
4.2.1	Internal calibrated leak	12
4.2.2	Procedure	12
4.3	Calibration with an external calibrated leak	13
4.3.1	External calibrated leak	13
4.3.2	Adaptor for external calibrated leaks	13
4.3.3	Calibration procedure with external leak in Hard Vacuum test	14
4.3.4	Calibration procedure with external leak in sniffing test	14
4.4	Calibration on concentration (sniffing test mode only)	14
4.5	Calibration of a leak detector connected to a pumping unit	15
4.5.1	Purpose	15
4.5.2	Target value	15
4.5.3	Procedure	15
<b>5</b>	<b>Maintenance / replacement</b>	<b>17</b>
5.1	Cleaning the covers	17
5.2	Dismantling the covers	17
5.2.1	Dismantling the front cover	17
5.2.2	Dismantling the rear cover	18
5.3	Maintenance of the internal calibrated leak	18
5.3.1	Replacement	18
5.3.2	Recalibration	19
5.3.3	Setting	19
5.4	Analyzer cell maintenance	19
5.4.1	Dismantling	20
5.4.2	Seals replacement	20
5.4.3	Filament replacement	21
5.5	Primary pump maintenance (on Wet Model)	22
5.5.1	Location	22
5.5.2	Oil level check	22
5.5.3	Oil quality inspection	23
5.5.4	Draining the pump	23
5.5.5	Flushing the pump	24
5.5.6	Filling the pump	25
5.5.7	Primary pump replacement	25
5.5.8	Replacement of the internal oil mist eliminator	26
5.5.9	Installation of an external mist eliminator	27
5.6	Maintenance of the turbomolecular pump	28
5.6.1	Location	28

---

5.6.2	Access to the fluid reservoir . . . . .	28
5.6.3	Replacing the operating fluid reservoir . . . . .	29
5.7	Pirani gauge maintenance . . . . .	30
5.7.1	Replacement . . . . .	30
5.8	Fan maintenance . . . . .	31
5.8.1	Location . . . . .	31
5.8.2	Replacement of the air inlet fan . . . . .	31
5.8.3	Replacement of the turbomolecular pump fan . . . . .	32
5.8.4	Replacement of the exhaust fan . . . . .	32
5.9	Air filters maintenance . . . . .	33
5.9.1	Air filters location . . . . .	33
5.9.2	Replacement of air filters no. 1 and no. 2 . . . . .	33
5.9.3	Replacement of the vacuum block air filter . . . . .	34
<b>6</b>	<b>Shutdown . . . . .</b>	<b>35</b>
6.1	Prolonged downtime . . . . .	35
6.2	Disposal . . . . .	35
<b>7</b>	<b>Malfunction . . . . .</b>	<b>36</b>
7.1	What happens in case of a fault . . . . .	36
7.1.1	Warning / fault display . . . . .	36
7.1.2	Warning / fault window . . . . .	36
7.1.3	List of warnings / faults . . . . .	37
7.2	Troubleshooting guide . . . . .	37
7.2.1	Installation of the application . . . . .	38
7.2.2	Consultation of the application . . . . .	38
<b>8</b>	<b>Service . . . . .</b>	<b>40</b>
<b>9</b>	<b>Spare parts . . . . .</b>	<b>41</b>
9.1	Ordering information . . . . .	41

# 1 About this manual

## 1.1 Validity

This maintenance manual is intended for the customers of the Pfeiffer Vacuum Company. It describes the product maintenance operations which can be performed by the user on the product concerned. **This documentation must be used with the operating manual of the product of the same name.**

The current maintenance manuals are also available on the Internet at [www.pfeiffer-vacuum.com](http://www.pfeiffer-vacuum.com).

This manual covers products with the following part numbers:

Part number	Description
JSVA00AxMx9x	ASM 340 Wet (all models)
KSBA00AxMM9A	ASM 340 Dry (all models)

### 1.1.1 Applicable documents

The document to be used in reference to this maintenance manual is:

ASM 340	Operating Instructions
ASM 340 Operating Instructions	P/n 121762 *

\*also available at [www.pfeiffer-vacuum.com](http://www.pfeiffer-vacuum.com)

## 1.2 Conventions

### 1.2.1 Safety instructions

Operating manual safety instructions Pfeiffer Vacuum are based on the UL, CSA, ANSI Z-535, SEMI S2, ISO 3864 and DIN 4844 certification standards. This document describes the following information and danger levels:

<b>DANGER</b>
<b>Imminent danger</b> Indicates an imminent hazardous situation that will result in death or serious injury.
<b>WARNING</b>
<b>Possibly imminent danger</b> Indicates an imminent hazardous situation that can result in death or serious injury.
<b>CAUTION</b>
<b>Possibly imminent danger</b> Indicates an imminent hazardous situation that can result in minor or moderate injury.
<b>NOTICE</b>
<b>Command or note</b> Command to perform an action or information about properties, the disregarding of which may result in damage to the product.

## 1.2.2 Pictographs



Prohibition of an action or activity in connection with a source of danger, the disregarding of which may result in serious accidents



Warning of a displayed source of danger in connection with operation of the unit or equipment



Command to perform an action or task associated with a source of danger, the disregarding of which may result in serious accidents



Important information about the product or this document

## 1.2.3 Instructions in the text



Work instruction: you must perform an operation here.

[XXXX]

You must press the **XXXX** key on the control panel.

<sup>4</sup>He

Helium 4

<sup>3</sup>He

Helium 3

H<sub>2</sub>

Hydrogen

## 1.2.4 Abbreviations used

I/O: Inputs/Outputs

## 1.2.5 Labels



Indicates an electric shock hazard in case of contact:

⇒ disconnect the electrical power supply before removing the cover and working on the product.

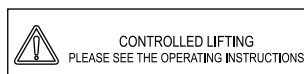

Indicates that the operator must:

⇒ move the equipment using the devices shown with this label,

⇒ comply with the rules for moving the equipment, taking weight and dimensions into account.



Locate a grounding point on the product.



Product subject to the treatment of waste electronic and electrical equipment in accordance with directive 2002/95/EC.

Other labels: see Operating Instructions.

## 2 Safety and maintenance information

### 2.1 Safety precautions



#### Duty to inform

Every person who is involved in maintenance and servicing work on the pump must read and follow the safety-relevant parts of all associated documents.



#### NOTICE

#### Exclusion of liability

Pfeiffer Vacuum accepts no responsibility concerning equipment damage, disrupted service or physical injury resulting from maintenance carried out by technicians who have not been trained in safety rules (EMC, electrical hazards, chemical pollution). Liability and warranty claims shall be inadmissible in this case.



#### WARNING

#### Risk of electric shock

Voltage and current can cause electric shock. Only skilled, authorised people may carry out maintenance work.

- Insulate and lock the power supply circuit by positioning the circuit breaker on "0"
- Disconnect the power cable from all power sources before any work on the product and/or removing the covers.



#### WARNING

#### Other located hazardous energies

Electrical circuit and other pressurized circuits as nitrogen are potential hazards:

- Always lock out these energy sources before working on the product.



#### NOTICE

#### Work/Handling the detector

The operator must not work on the product to move it or carry out maintenance until it has come to a complete shutdown! When the circuit breaker is set at "0", you must:

- Unplug the power cable.
- Wait for the control panel screen to turn off completely before working on the product and/or removing the covers.

- Wait 5 minutes after switch-off before working on the product.
- When you order spare parts, you must mention everything featured on the product nameplate.
- Comply with all safety and risk prevention instructions in accordance with local safety standards.
- Regularly check compliance with all precautionary measures.
- Do not switch on the product if the covers are not in place.
- To return the product to one of our Pfeiffer Vacuum service centers, read the after-sales Service procedure and complete the declaration of contamination available on our website.
- Use the original packaging to return the product to a Pfeiffer Vacuum service center: the manufacturer shall not be held liable for any damage resulting from transport in unsuitable packaging.

## 2.2 Protective equipment

In some situations, personal protective equipment must be worn when handling the detector and its components. Customers must provide operators with the necessary equipment. This equipment must be checked regularly and used in accordance with the supplier's recommendations.



<b>DANGER</b>
<p><b>Health hazard in case of contact with the operating fluid</b></p> <p>Contact with or inhaling products such as oil from the primary pump can cause irritation.</p> <p>→ Wear appropriate protective equipment when carrying out maintenance or adding/ draining oil.</p>



<b>WARNING</b>
<p><b>Risk of injury through falling objects</b></p> <p>When transporting parts/items by hand, there is a danger through loads slipping and falling down.</p> <p>→ Carry small and mid-size parts/items two-handed.</p> <p>→ Carry parts/items &gt; 20 kg with a suitable lifting device.</p> <p>→ Wear safety shoes with steel toe cap according to directive EN 347.</p>



<b>WARNING</b>
<p><b>Risk of injury through hot surfaces</b></p> <p>The products are designed so as not to present a thermal risk for the operator's safety. However, specific operating conditions may exist that require extra caution from users due to the high temperatures (surfaces &gt; 70 °C for parts inside the covers):</p> <p>→ Leave the part to cool before working on the product.</p> <p>→ If necessary wear protective gloves according to directive EN 420.</p>



<b>CAUTION</b>
<p><b>Risk of pinching</b></p> <p>When handling the storage tank cover, there is a risk of fingers becoming pinched.</p>

## 2.3 Maintenance preparation



<b>NOTICE</b>
<p><b>Work/Handling the detector</b></p> <p>The operator must not work on the product to move it or carry out maintenance until it has come to a complete shutdown! When the circuit breaker is set at "0", you must:</p> <p>→ Unplug the power cable.</p> <p>→ Wait for the control panel screen to turn off completely before working on the product and/or removing the covers.</p>

- Disconnect the detector from the part/installation to be tested: install the blanked-off flange on the detector's inlet (accessory supplied with the product or available upon request (see **Accessories** chapter of the Operating Instructions).
- Handle the detector so it can be moved in the maintenance area (see **Handling** chapter of the Operating Instructions).
  - clean, dust-free and ventilated room,
  - appropriate protective equipment.



## 2.4 Tools and spare parts

The tools necessary for the maintenance of the detector are available in the maintenance kit supplied with the product. Depending on the maintenance operation, other tools may be needed, at the customer's expense.



### **Necessary spare parts**

Replacement of defective components with parts that are not genuine, jeopardizes the initial safety conditions of the equipment.

- Use only spare parts available by asking Pfeiffer Vacuum Service.
- Ordering information is available in chapter **Spare parts**.
- To correctly identify the product when communicating with Pfeiffer Vacuum, always have the information from the product rating plate available.

### 3 Maintenance intervals and responsibilities

Level 1 and 2 maintenance operations of the service frequency table are described in this maintenance manual.  
 Level 3 overhaul operations require the intervention of a technician from the Pfeiffer Vacuum Service network.

Component Operation	Number of hours in use				Level <sup>(3)</sup>	Site <sup>(4)</sup>
	Routine maintenance <sup>(2)</sup>	8,600	17,200	Others		
<b>Primary pump RVP 1015 (Model Wet)</b>						
Oil level and appearance check	x				II	OS
Oil change		x		4,300 hours if <sup>(1)</sup>	II	OS
Pump replacement				In case of failure	III	OS
<b>2 AMD1 Primary pumps (Model Dry)</b>						
Replacement of the diaphragms and valves			x		III	OS
Pump replacement				In case of failure	III	OS
<b>Oil mist eliminator</b>						
Oil mist eliminator replacement		x		4,300 hours if <sup>(1)</sup>	II	OS
<b>Splitflow 50 turbomolecular pump</b>						
Operating fluid reservoir replacement		x			II	OS
Bearings replacement				In case of failure	III	OS
Replacement of the TC 110 frequency converter				In case of failure	III	OS
Pump replacement				In case of failure	III	OS
<b>Analyzer cell</b>						
Filament replacement				In case of failure	I	OS
<b>Valves</b>						
Replacement of all valves				Every 500,000 tests	III	OS
<b>Air inlet filter</b>						
Cleaning or replacement of the air inlet filter	x				II	OS
<b>Pirani gauge</b>						
Setting	x			Every 4,300 hours (recommended)	I	OS
Replacement				In case of failure	II	OS
<b>Smart sniffer probe</b>						
Capillary filter replacement	x			Every 160 hours (recommended)	I	OS
Sintered filter replacement	x			Every 160 hours (recommended)	I	OS
<b>Standard sniffer probe</b>						
Sintered filter replacement	x			Every 160 hours (recommended)	I	OS
<b>Fans</b>						
Fan replacement				In case of failure	II	OS
Cleaning or replacement of the fan air filter	x				I	OS
<b>Calibrated leak</b>						
Recalibration			x	Or every 3 years	II	WS
<b>Leak detector</b>						
Service	x			Every 3 years (recommended)	III	OS/WS

(1) In case of severe application (with significant flow or contamination)

(2) Routine maintenance: according to usage conditions

(3) Level :  
 I = Operator  
 II = Technical or trained operator  
 III = Service center

(4) Site:  
 OS = On site  
 WS = In Pfeiffer Vacuum service center.

### 3.1 Maintenance time monitoring

The cycle counters of the primary pump and turbomolecular pump alert the operator that a maintenance operation must be performed (see ***Maintenance Menu of the Operating Instructions***).

## 4 Calibration

### 4.1 Purpose

Calibration helps ensure that the leak detector is correctly adjusted to detect the tracer gas selected and display the correct leak rate. A calibrated leak is used to calibrate the leak detector.

Depending on the test method, different types of calibration can be performed.

	Test method	
	Hard Vacuum	Sniffing
With the internal calibrated leak	yes	yes (*)
With an external calibrated leak	yes	yes
With the ambient air (ambient air not contaminated by the tracer gas)	no	yes

(\*) in this case, the flow of the sniffer probe is not included in the leak detector calibration process.

### 4.2 Calibration with the internal calibrated leak

#### 4.2.1 Internal calibrated leak

The internal calibrated leak is specifically designed for the leak detector. It is composed of:

- a Helium 4 reservoir (no internal calibration with the other tracer gases),
- a temperature sensor (to take into account the effect of temperature on the leak rate),
- an integrated diaphragm (to calibrate the leak rate),
- an identification label (identical to the identification label of an external calibrated leak).

The calibrated leak is supplied with a calibration certificate.

#### 4.2.2 Procedure

When switching the leak detector on, calibration with the internal calibrated leak is automatically initiated if the calibration parameter is set on 'Start-up' and if the type of calibrated leak is set on 'Internal'.

- Check the leak settings (corrected leak rate to take temperature and time into account if necessary) (see *Spectro Menu of the Operating Instructions*).
- Press **[Auto cal]** key to launch a calibration.

In the case of intensive use of the detector, a spare internal calibrated leak is recommended. If this is not possible, the detector can still be used and calibrated using an external calibrated leak.



#### NOTICE

##### Detector calibration

When switched on, the detector suggests that the operator carry out an auto-calibration (if calibration parameter = operator). For the optimal use of the detector, **this auto-calibration must be performed**. In all situations, a manual or automatic calibration must be performed:

- at least once a day
- to optimise the measurement reliability for high sensitivity tests
- if it is uncertain whether the detector is working properly
- during intense and continuous operation: start an internal calibration at the beginning of each work session (e.g. work in teams, every 8 hours).

## 4.3 Calibration with an external calibrated leak

### 4.3.1 External calibrated leak

The operator must use a calibrated leak containing the tracer gas selected ( $^4\text{He}$ ,  $^3\text{He}$  or  $\text{H}_2$ ). There are several types of external calibrated leaks, with or without reservoir, with or without valve, covering several leak ranges. Use calibrated leaks from the ranges indicated below.

Gas	Minimum Value	Maximum Value
$^4\text{He}$	$\approx 1 \cdot 10^{-9}$ mbar·l/s $\approx 1 \cdot 10^{-10}$ Pa·m <sup>3</sup> /s	$1 \cdot 10^{-4}$ mbar·l/s $1 \cdot 10^{-5}$ Pa·m <sup>3</sup> /s
$^3\text{He}$	$\approx 3 \cdot 10^{-7}$ mbar·l/s $\approx 3 \cdot 10^{-8}$ Pa·m <sup>3</sup> /s	$1 \cdot 10^{-4}$ mbar·l/s $1 \cdot 10^{-5}$ Pa·m <sup>3</sup> /s
$\text{H}_2$	$\approx 5 \cdot 10^{-6}$ mbar·l/s $\approx 5 \cdot 10^{-7}$ Pa·m <sup>3</sup> /s	$1 \cdot 10^{-4}$ mbar·l/s $1 \cdot 10^{-5}$ Pa·m <sup>3</sup> /s



**The choice of external calibrated leak depends on the needs of the application: use a calibrated leak from the same leak rate range as the leak to be measured.**

The manufacturer does not provide calibrated leaks in  $^3\text{He}$  and  $\text{H}_2$ .

### 4.3.2 Adaptor for external calibrated leaks

A DN 16 ISO-KF or DN 25 ISO-KF adaptor helps calibrate the detector with an external calibrated leak in sniffing test mode (with Standard probe only).

Adaptor part numbers: (see 9)

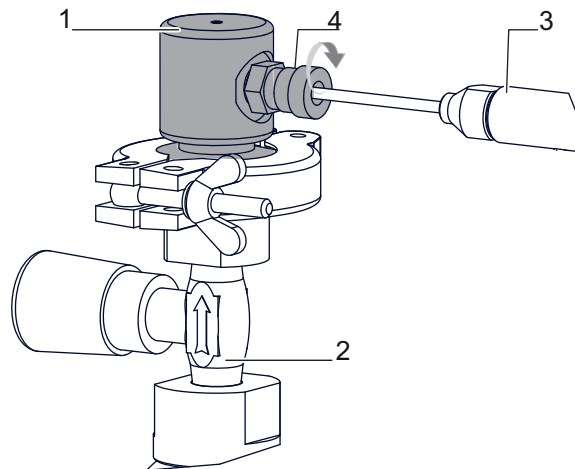

Fig. 1: Adaptor installation

- Attach the adaptor (1) to the external calibrated leak (2) used for the calibration with centering ring and a clamp.
- Start a calibration: press the **[Auto cal]** function key.
- Fit the sniffer probe (3) in the calibration opening.
- Tighten the fixing screw (4). Follow the calibration process indicated on the control panel.
- Loosen the fixing screw (4).
- Remove the sniffer probe from the calibration opening.
- Continue the calibration process indicated on the control panel.
- Wait 10 s (at least) before reading the leak rate.

Notes

- The displayed leak rate takes  $^4\text{He}$  into account (if  $^4\text{He}$  used as tracer gas).

Example:

- calibration with a leak of  $2 \cdot 10^{-5}$  mbar·l/s
- the displayed leak rate is:  $2 \cdot 10^{-5} + 5 \cdot 10^{-6} = 2.5 \cdot 10^{-5}$  mbar·l/s

### 4.3.3 Calibration procedure with external leak in Hard Vacuum test

- Allocate a function key to **[Auto.Cal]** (see **Configuration Menu** in the *Operating Instructions*).
- Configure the following settings:
  - test method = hard Vacuum (see **Test Menu**)
  - type of calibrated leak = external (see **Spectro Menu**)
  - calibration = operator (see **Advanced Menu**)
- Check the settings and value of the external calibrated leak used (see **Spectro Menu**). Correct the temperature, month and year if necessary.
- Select the tracer gas of the external calibrated leak.
- Place the external calibrated leak on the detector inlet port.
- Verify that the detector is on Stand-by.
- Press the **[Auto.Cal]** function key to start the calibration.
- Follow the instructions provided by the leak detector to move to the next stage.

At the end of the calibration, the detector returns to Stand-by mode.



**Recommended procedure when the measuring range differs from the value of the internal calibrated leak.**

### 4.3.4 Calibration procedure with external leak in sniffing test

- Allocate a function key to **[Auto.Cal]** (see **Configuration Menu** in the *Operating Instructions*).
- Configure the following settings:
  - test method = sniffing (see **Test Menu**)
  - type of calibrated leak = external (see **Spectro Menu**)
  - calibration = operator (see **Advanced Menu**)
- Check the settings and value of the external calibrated leak used (see **Spectro Menu**). Correct the temperature, month and year if necessary.
- Select the tracer gas of the external calibrated leak.
- Connect the sniffer probe to the detector.
- Verify that the detector is on Stand-by.
- Press the **[Auto.Cal]** function key to start the calibration.
- Follow the instructions provided by the leak detector: press **[Next]** to move to the next stage.

At the end of the calibration, the detector returns to Stand-by mode.

## 4.4 Calibration on concentration (sniffing test mode only)



**NOTICE**

**Before launching this function, make sure that the leak detector is in an environment free of tracer gas pollution.**

Concentration = container at atmospheric pressure with a gas mixture of a known <sup>4</sup>He concentration.

**Procedure**

- Allocate a function key to **[Auto.Cal]** (see **Configuration Menu** in the *Operating Instructions*).
- Configure the following settings:
  - test method = sniffing (see **Test Menu**)

- type of calibrated leak = concentration (see **Spectro Menu**)
  - calibration = operator (see **Advanced Menu**)
  - tracer gas =  $^4\text{He}$  (see **Spectro Menu**)
- Connect the sniffer probe to the detector.
- Verify that the detector is in Stand-by mode.
- Press the **[Auto.Cal]** function key to start the calibration.
- Follow the instructions provided by the leak detector: press **[Next]** to move to the next stage.

At the end of the calibration, the detector returns to Stand-by mode.

## 4.5 Calibration of a leak detector connected to a pumping unit

### 4.5.1 Purpose

When the leak detector is connected to an installation equipped with its own pumping unit, only part of the leak will be analyzed by the leak detector. Calibration helps obtain a direct reading of the leak rate by taking into account the loss of tracer gas of the leak pumped by the pumping unit.

Calibration is performed via the Correction function.

### 4.5.2 Target value

3 possible target values:

Target value =	Hard Vacuum	Sniffing
External calibrated leak value <sup>(1)</sup>	✓	✓
Tracer gas concentration of a container filled with a known gas mixture including the tracer gas		✓
Ambient air (be careful with the tracer gas concentration: no tracer gas pollution)		✓

(1) When an external calibrated leak is used, it is recommended to take into account the calibration date and temperature effect for calculating the target value from the calibrated leak value featured on its identification label.

- Corrected leak rate = target value = measured leak value x correction factor.
- Background corrected leak rate = background measured leak rate x correction factor.

### 4.5.3 Procedure

The correction must be made once the leak detector has been calibrated.

**Note** The correction must be made using the same test method as that used by the operator. If the operator works using both test methods (Hard Vacuum and sniffing), he/she must make a correction for each method.

- Allocate a **[Correction]** function key (see **Configuration Menu** in the *Operating Instructions*).
- Select the 'Hard Vacuum' or 'sniffing' test mode.
- If 'Sniffing test', connect the sniffer probe to the detector: connect it to an external calibrated leak or place it in a container with a known concentration.
- Press **[START STANDBY]** to start a test.
- Press the **[Correction]** function key.
- if the value of the correction factor to be applied is known:
    - Press **[Value]** and configure the correction factor to be applied. The correction factor is the coefficient to be applied to the measured leak rate.
    - Press **[Return]** to exit the function.
  - if the value of the target leak rate is known (value of the internal/external calibrated leak or concentration):
    - Press **[AutoCal] [Target]** and configure the target leak rate.
    - Press **[Run]** to make the correction.

- Press **[Return]** to exit the function.
- ➔ Press **[Reset]** to reset the correction factor to 1.

The '**COR**' indicator light (see **Standard screen** of the *Operating Instructions, ref. 9*) is illuminated on the control panel as soon as the value of the correction factor is not 1.

The digital display takes into account the correction factor applied.

The bargraph display does not take into account the correction factor applied.



## 5 Maintenance / replacement

### 5.1 Cleaning the covers

- Clean the covers using a lint-free cloth and a product which does not damage printed surfaces and self-adhesive labels.

### 5.2 Dismantling the covers

- Tools
- 5 mm Allen key supplied in the maintenance kit

#### 5.2.1 Dismantling the front cover

- Shut down the detector (Position the circuit breaker **MS** on **0**, control panel switched off and mains power cable disconnected).
- Install the blanked-off flange on the detector's inlet port.
- Remove the black flange around the inlet port.
- Lift the lid of the storage tank: loosen and remove the 2 upper fixing screws.
- Loosen and remove the 2 side fixing screws.

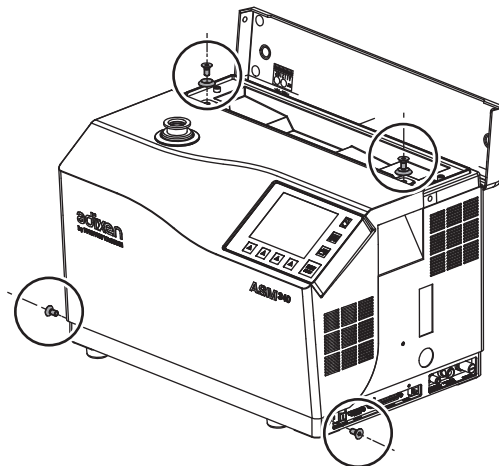

Fig. 2: Location of the front cover dismantling screw

- Take off the front cover and remove it from the detector (1.5 m max).
- On the supervisor board, disconnect the connector from the control panel to fully release the cover.

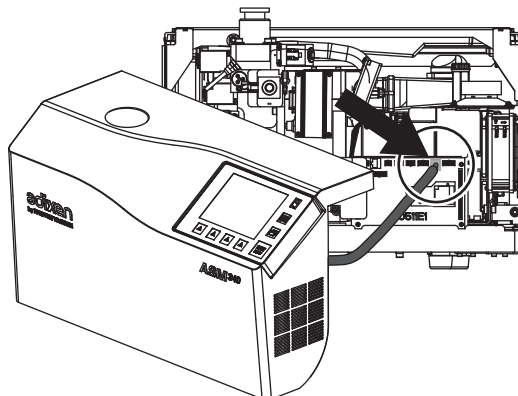
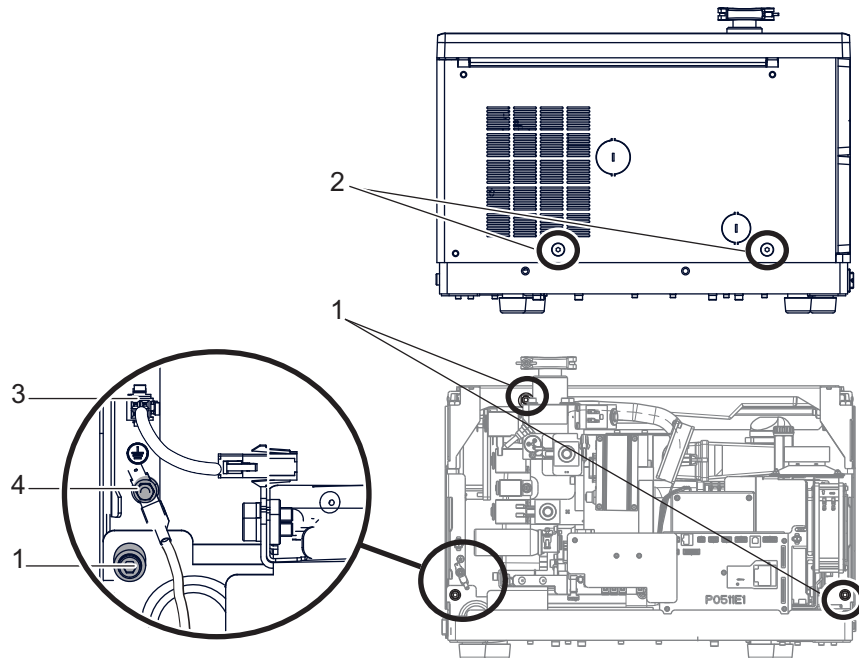

Fig. 3: Disassembly of the front cover

## 5.2.2 Dismantling the rear cover

- ➔ Dismantle the front cover. Loosen and remove the 5 fixing screws (1), (2) and their washers.
- ➔ Disconnect the harness (3) and the ground point (4).
- ➔ Remove the rear cover.



When reassembling the cover, make sure that the 5 fixing screws for the rear cover on the frame are in place and properly screwed.

## 5.3 Maintenance of the internal calibrated leak

### 5.3.1 Replacement

- |                               |  |
|-------------------------------|--|
| <b>Tools/<br/>Spare parts</b> | <ul style="list-style-type: none"> <li>• 3 mm Allen key supplied in the maintenance kit</li> <li>• Internal calibrated leak (see 9)</li> </ul> |
|-------------------------------|--|

### NOTICE

Change the internal calibrated leak if it has significant impact marks.

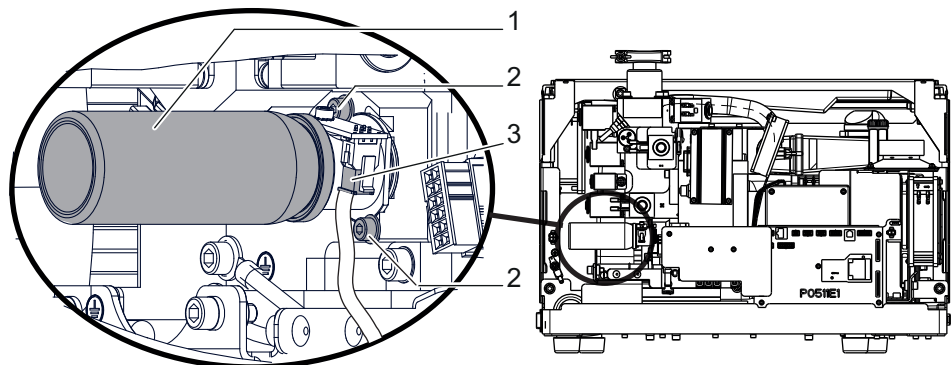

Fig. 4: Calibrated leak maintenance

- ➔ Remove the front cover.
- ➔ Disconnect the temperature sensor (3) from the calibrated leak. **Never separate the temperature sensor from the calibrated leak.**

- Loosen the 2 fixing screws (2) without removing them.
- Rotate the internal calibrated leak by 90°.
- Replace the leak (1).
- Rotate the calibrated leak by 90° so that the temperature sensor is positioned underneath the valve.
- Connect the temperature sensor (3).
- Update the settings of the internal calibrated leak (see **Spectro Menu of the Operating Instructions**).

### 5.3.2 Recalibration

Most calibrated leaks can be used for many years ( $\approx 6$  years) even though the tracer gas is permanently escaping (the leak rate is very low compared with the amount of tracer gas contained in the reservoir: annual loss is indicated on the calibrated leak identification label).

However, to guarantee the reliability of the test, we recommend that you regularly recalibrate (3 years maximum) every leak with reservoir to check its leak rate: this applies to both internal and external calibrated leaks.

Return the leak to your Pfeiffer Vacuum service center for recalibration purposes.

### 5.3.3 Setting

- The setting of the calibrated leak must be updated every time a calibrated leak (internal or external) is replaced or after a recalibration (see **Spectro Menu in the Operating Instructions**).

This operation can be carried out with the information featured on the calibrated leak identification label or the certificate supplied with the calibrated leak.

- If type = 'internal' is set for the calibrated leak, the internal calibrated leak parameters are displayed in the menu.
- If type = 'external' is set for the calibrated leak, the external calibrated leak parameters are displayed in the menu.

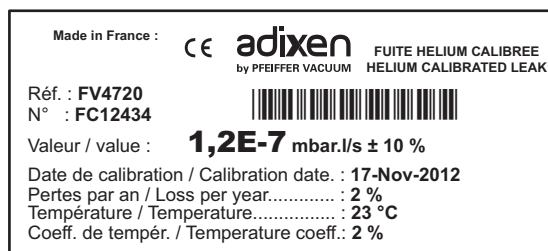

Fig. 5: Example of identification label

## 5.4 Analyzer cell maintenance



### NOTICE

#### Cleanliness guarantee

During vacuum component maintenance operations, avoid any contamination which could subsequently result in the degassing of the parts. To avoid this:

- perform the maintenance in an appropriate area (clear, dust-free and ventilated)
- use non-woven materials
- dust the parts with filtered dry air
- wear unpowdered vinyl gloves (clean room gloves)

### 5.4.1 Dismantling

- Tools**
- Torx screwdriver supplied in the maintenance kit

**Procedure**



**WARNING**

**Risk of burning associated with hot surfaces**

When in operation, certain mechanical parts can reach high temperatures. If the detector was used recently:

→ Let it cool down for at least 15 minutes before working on the analyzer cell.

→ When relevant, use protective gloves in accordance with the EN 420 standard.

→ Create an air inlet in the cell via the **Maintenance Menu** (see *Operating Instructions*).

→ Shut down the detector (Position the circuit breaker on 0, control panel switched off and mains power cable disconnected).

→ Remove the front cover (see 5.2.1).

→ Disconnect the harness (1) from the cell.

→ Loosen the 6 fixing screws (2) of the cell.

→ Free the analyzer cell manually and vertically.

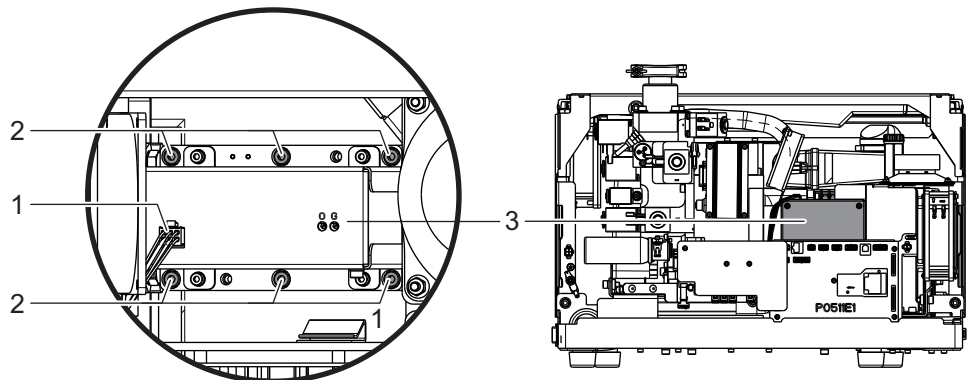

Fig. 6: Dismantling the analyzer cell

### 5.4.2 Seals replacement

Check the condition of the seals every time you work on the analyzer cell (filament replacement for example): change them if necessary.

- Spare parts**
- 2 seals (see 9)

Seal is consumables. As such, it is not covered by the warranty.

**Procedure**

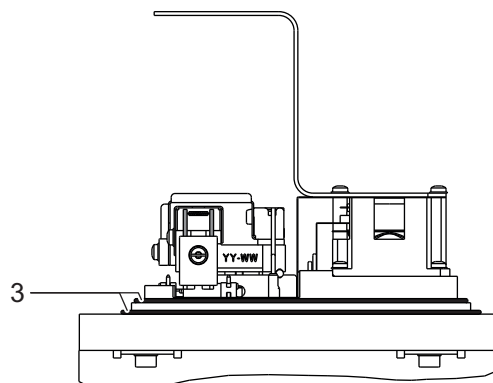

Fig. 7: Replacement of the seals

→ Remove the analyzer cell from the detector (see 5.4.1).

→ Replace the 2 seals (3). **Never lubricate the seals.**

### 5.4.3 Filament replacement

- Tools**
- Torx screwdriver supplied in the maintenance kit
  - Flat pliers
  - Filament (see 9)

Filament is consumables. As such, it is not covered by the warranty.

#### Procedure



**The oxidation of the iridium filament is normal: do not touch the filament with your fingers.**

- Remove the analyzer cell from the detector (see 5.4.1).
- Remove the fixing screw (4) and the washer of the defective filament.
- Remove the 2 fastening clips (5) using flat pliers (2 new clips are supplied with the spare filament).
- Replace the filament.
- Reset the counter of the new filament (see **Maintenance Menu** in the *Operating Instructions*).

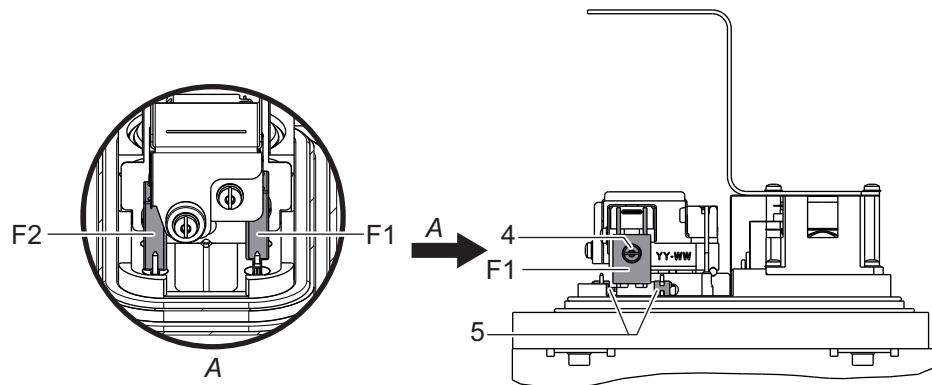

**Fig. 8: Dismantling the filament**

F1	Filament 1 in the menu
F2	Filament 2 in the menu

- Make sure that the filament connectors (6) are perpendicular to the supporting surface and parallel to each other.

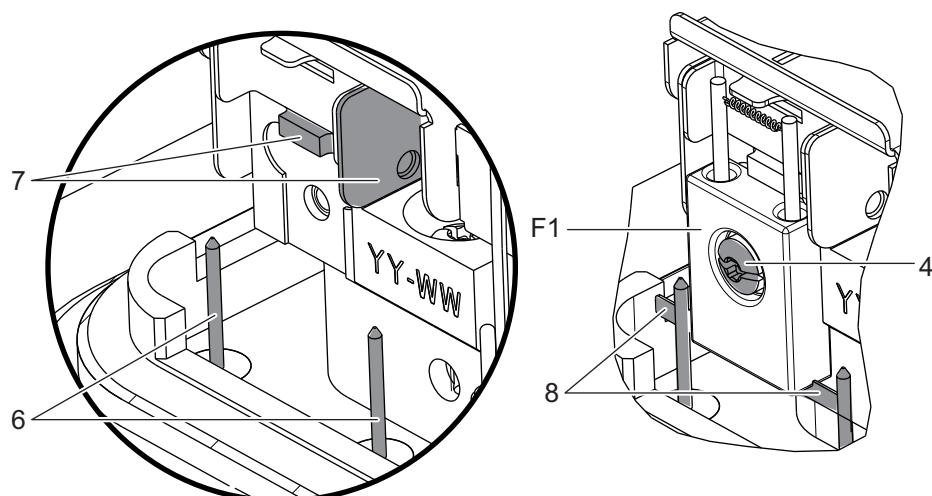

**Fig. 9: Positioning the filament**

- Fit the new filament in its housing against the 2 centring stops (7). Attach it with the screw (4) and washer supplied with the filament, using the Torx screwdriver.

- Take a fastening clip (5) with the flat pliers: this clip will ensure electrical contact between the filament and the cell (A Fig. 10).
- Fit the clip on the connector (6) and on the strip of the filament (8) (B Fig. 10).
- Push in the clip with the pliers until it stops (C Fig. 10).
- Repeat the last 3 operations for the second connector.
- Reset the counter of the new filament (see **Maintenance Menu** in the *Operating Instructions*).

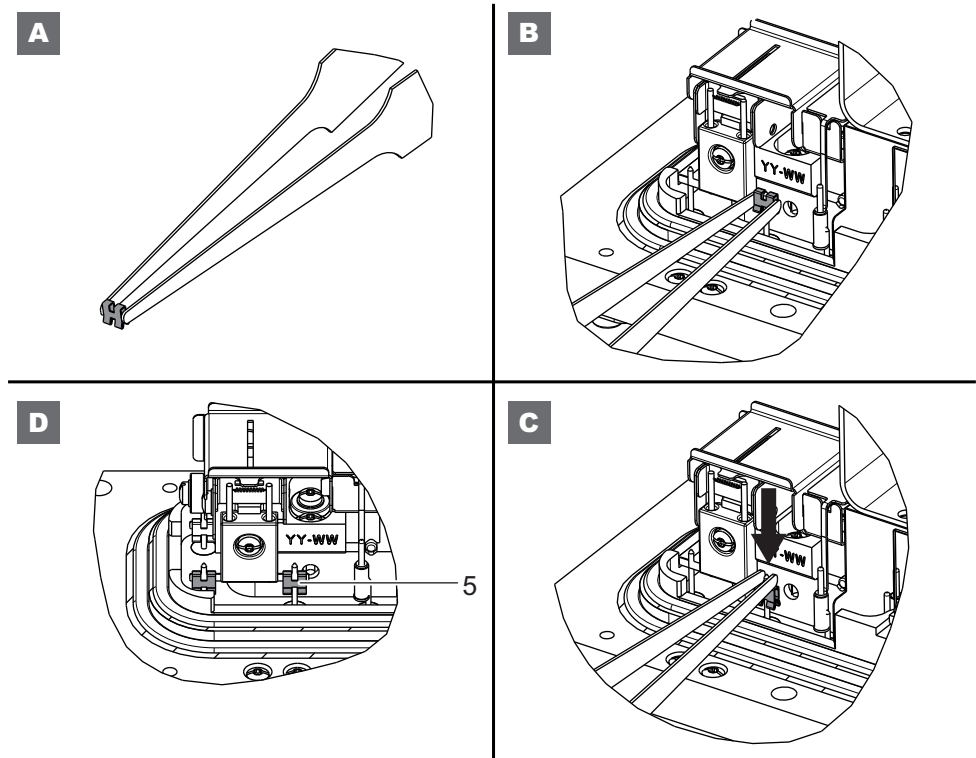

Fig. 10: Fitting of the fastening clip

## 5.5 Primary pump maintenance (on Wet Model)

### 5.5.1 Location

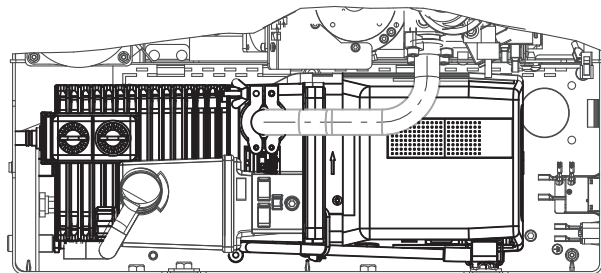

Fig. 11: Primary pump location

### 5.5.2 Oil level check

For the pump to function in optimal conditions, the oil level must be checked regularly.

- If the oil level is not between the Min. and Max. marks, adjust it (see 5.5.6).

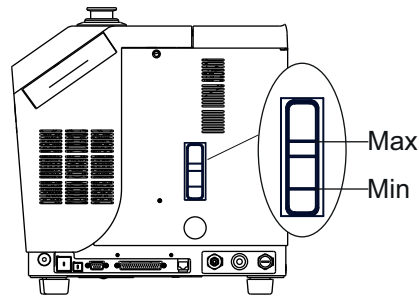

Fig. 12: Oil level check

### 5.5.3 Oil quality inspection

For the pump to function in optimal conditions, oil quality must be checked regularly. Thickening and darkening of the oil, combined with a burning smell, are signs of lubricant deterioration.

- Drain the pump (see 5.5.4).
- Then flush it using fresh oil (see 5.5.5).
- Then fill the pump with fresh oil (see 5.5.6).

### 5.5.4 Draining the pump



#### NOTICE

**Drain the primary pump before removing it from the detector and before any product shipment.**

#### DANGER

##### Health hazard in case of contact with the operating fluid

Contact with or inhaling products such as oil from the primary pump can cause irritation.

- Wear appropriate protective equipment when carrying out maintenance or adding/ draining oil.

#### WARNING

##### Risk of intoxication in case of contact with substances hazardous to health.

Appropriate precautions should always be taken when handling waste oil:



- Wear appropriate protective equipment when draining and flushing the pump.
- Do not pour waste oil down the drain. Have it destroyed by a qualified company if necessary.
- Take the necessary safety precautions to avoid generating health risks or polluting the environment in case of contamination.
- Decontaminate the parts affected before performing maintenance work.

#### Tools/ Consumables

- 1 oil recovery container (capacity = 1.5 l)
- 1 funnel supplied with the product
- 1 drain connector supplied with the product
- 1 oil can (1 liter) (see 9).

#### Procedure

**The pump must be drained when it is hot.**

- Position the circuit breaker  on I.
- Wait 5 minutes.
- Position the circuit breaker  on 0: wait for the control panel to switch off
- Disconnect the mains power cable
- Install a container (4) underneath the drain plug.

→ Connect the drain connector (5).

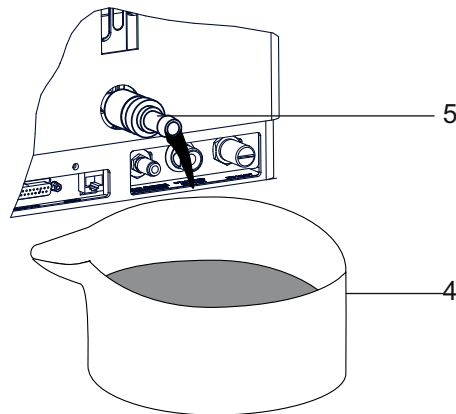

Fig. 13: Fitting of the drain connector

- Recover waste oil.
- When all the oil has been drained, remove the drain connector.
- Fill with fresh oil (see 5.5.6).

### 5.5.5 Flushing the pump



#### NOTICE

##### Only use approved operating fluids

The pumps are factory tested using adixen oil.

→ The same oil must be used during operation. The oil safety data sheet is available on the website.

#### Tools /Consumables

- 1 oil recovery container (capacity = 1.5 l)
- 1 funnel supplied with the product
- 1 drain connector supplied with the product
- 1 oil can (1 liter) (see 9)

#### Procedure

- Drain the oil casing (see 5.5.4).
- Leave the drain connector on the detector and the waste oil recovery container in place.
- Remove the plug of the filling opening (1) from the rotary vane pump (2).

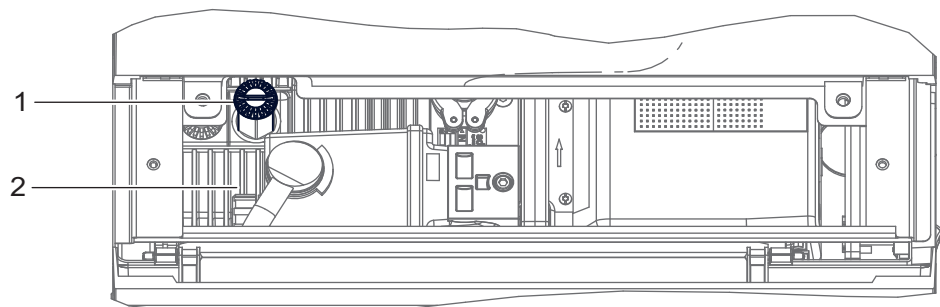

Fig. 14: Oil fill opening

- Put the funnel (included with the detector) in the oil fill opening (3) (Fig. 15).
- Pour the flushing oil very slowly (full 1 liter can) into the filling opening.
- When all the flushing oil has been emptied into the container, remove the drain connector.
- Fill the pump with fresh oil (see 5.5.6).
- Tighten the filling plug on the pump.



### 5.5.6 Filling the pump



#### NOTICE

##### Only use approved operating fluids

The pumps are factory tested using adixen oil.

→ The same oil must be used during operation. The oil safety data sheet is available on the website.



#### DANGER

##### Health risk in case of oil contact

The pumps are delivered empty of oil: the oil is delivered in separate containers.

→ Wear mask, gloves, protective glasses to fill the pumps with oil.



#### Tools/ Consumables

- 1 funnel supplied with the product
- 1 oil can (1 liter) (see 9)

#### Procedure

- Make sure that the detector is off (circuit breaker  on 0, control panel switched off and power cable disconnected) and in horizontal position.
- Make sure the drain connector is not connected.
- Loosen the filling plug (1) (Fig. 14).
- Install the funnel in the filling opening (3).

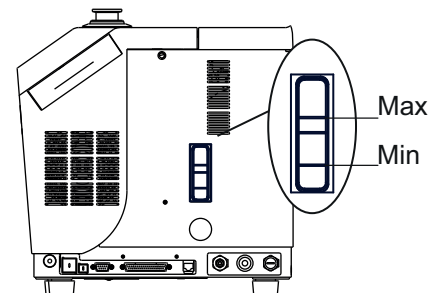
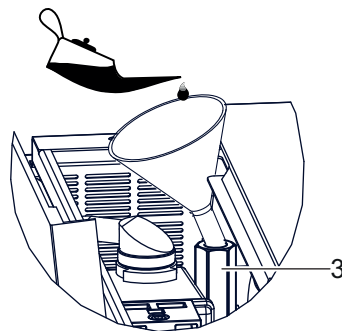

Fig. 15: Oil filling and oil level check

- Fill with oil to the highest level.
- Tighten the filling plug (1).

### 5.5.7 Primary pump replacement



#### NOTICE

**Drain the primary pump before removing it from the detector and before any product shipment.**

#### Tools/Spare parts

- 5 mm Allen key supplied in the maintenance kit
- Pair of scissors
- Primary pump (see 9)

#### Procedure

- Make sure that the detector is off (circuit breaker  on 0, control panel switched off and mains power cable disconnected).
- Remove the front and rear covers (see 5.2).
- Remove the tightening clamp (1).
- Disconnect the pump power cable (2).
- Cut the plastic fixing clamp (4) of the pump power cable.

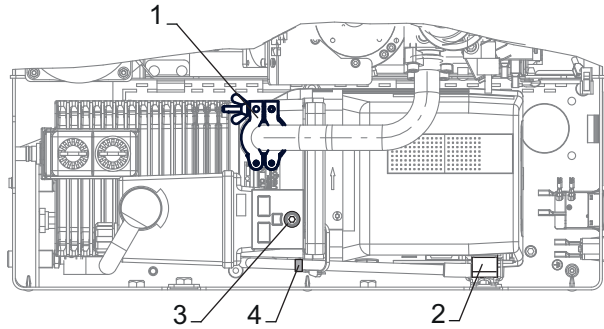
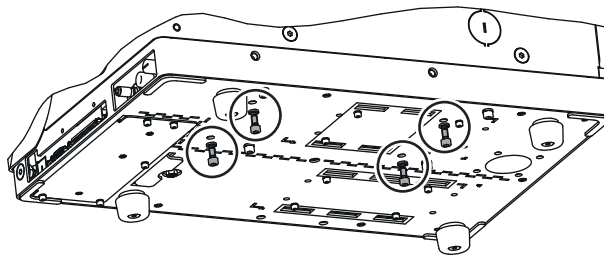

Fig. 16: Dismantling the primary pump

- Loosen the screw (+ washer) of the mist eliminator's mounting bracket (3), then remove the mist eliminator.
- Loosen the 4 fixing screws (+ washers) of the pump underneath the detector frame.



When dismantling the primary pump to send it to the service center, keep the tightening clamp, power cable and entire mist eliminator unit (mist eliminator + bracket + screws). **Never send accessories with the pump.**

After pump service or replacement:

- Put the pump back into the frame in reverse dismantling order.
- Reset the timer of the primary pump (see **Maintenance Menu** in the *Operating instructions*).

### 5.5.8 Replacement of the internal oil mist eliminator

- |                          |   |
|--------------------------|---|
| <b>Tools/ Spare part</b> | <ul style="list-style-type: none"> <li>• 5 mm Allen key supplied in the maintenance kit</li> <li>• Oil mist eliminator: (see 9)</li> </ul>  |
| <b>Procedure</b>         | <ul style="list-style-type: none"> <li>→ Make sure that the detector is off (circuit breaker <b>MIS</b> on <b>0</b>, control panel switched off and mains power cable disconnected).</li> <li>→ Remove the storage tank (2 screws + washers).</li> <li>→ Loosen the screw (2) of the oil mist eliminator's mounting bracket.</li> <li>→ Remove the fixing clamp of the hose (3) and then the hose.</li> <li>→ Replace the oil mist eliminator.</li> </ul> |

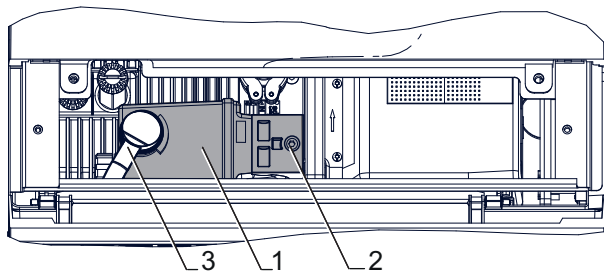

Fig. 17: Internal oil mist eliminator disassembly

### 5.5.9 Installation of an external mist eliminator

The operator can use an external oil mist eliminator to replace the internal oil mist eliminator installed on the detector: this modification requires connecting an accessory: an exhaust connector for the pump.

- Tools**
- 5 mm Allen key supplied in the maintenance kit
  - Wide, flat-head screwdriver
  - Exhaust connector (see 9)
  - O-ring (see 9)
  - External oil mist eliminator, DN 25 ISO-KF connection supplied by the customer.

- Procedure**
- ➔ Remove the rear cover (see 5.2.2).
  - ➔ Dismantle the internal mist eliminator (1).
  - ➔ Loosen the locking screw (2) of the side blanked-off flange (3).
  - ➔ Unscrew and remove the blanked-off flange (3) and the O-ring (4).

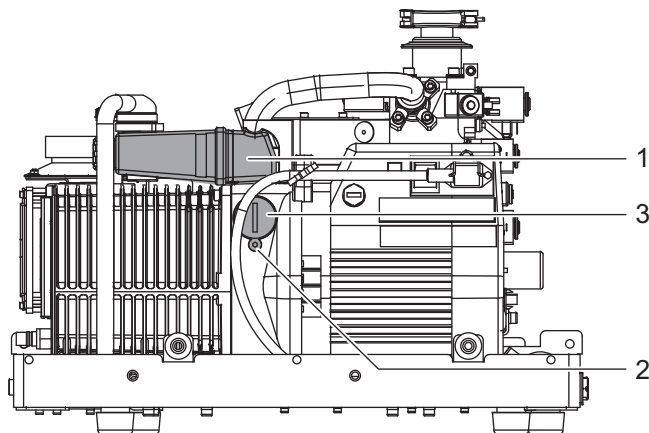

- ➔ Install a replacement O-ring (5), tighten the exhaust connector (6) and the locking screw (2).
- ➔ Install the O-ring (4) and the blanked-off flange (3) to replace the internal mist eliminator, on top of the pump.
- ➔ On the rear cover, using a screwdriver, remove the cap (7) to allow the passage of the exhaust connector.

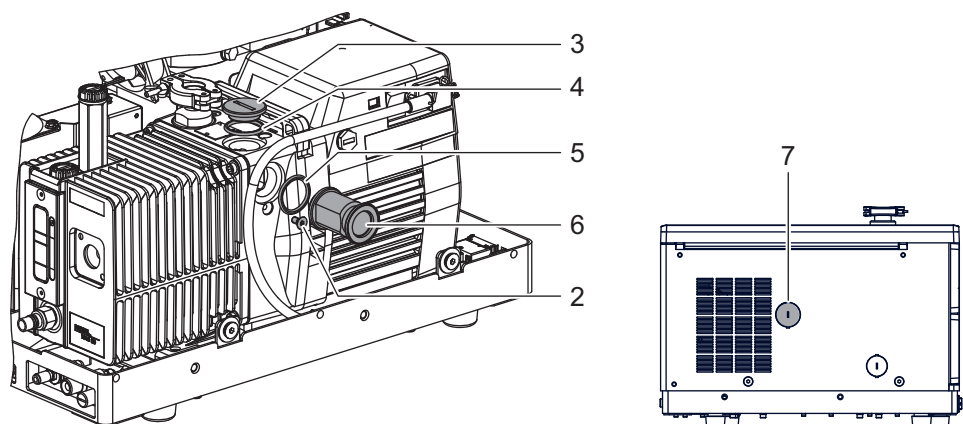

Fig. 18: Installation of the exhaust connector

## 5.6 Maintenance of the turbomolecular pump



### WARNING

#### Risk of burning associated with hot surfaces

When in operation, certain mechanical parts can reach high temperatures. If the detector was used recently:

- Let it cool down for at least 10 minutes before working on the turbomolecular pump.
- When relevant, use protective gloves in accordance with the EN 420 standard.

### 5.6.1 Location

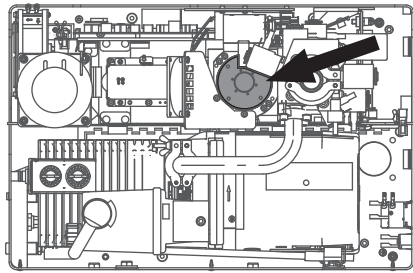

Fig. 19: Turbomolecular pump location

### 5.6.2 Access to the fluid reservoir

- |                    |                            |
|--------------------|----------------------------|
| <b>Tools/</b>      | • Flat pliers              |
| <b>Spare parts</b> | • 2 flat-head screwdrivers |
|                    | • Special tool             |
|                    | • Torque wrench (13 N.m)   |
|                    | • Clean, lint-free cloth   |
|                    | • Oil reservoir (see 9)    |

- Procedure**
- Create an air inlet in the cell (see **Maintenance Menu** in the *Operating Instructions*).
  - Shut down the detector (circuit breaker **MS** on **0**, control panel switched off and mains power cable disconnected). Let it cool down for 10 mn if necessary.
  - Remove the front cover (see 5.2.1).
  - Loosen the fixing screw (1) and remove the coil (2). **Do not dismantle the operator (3).**

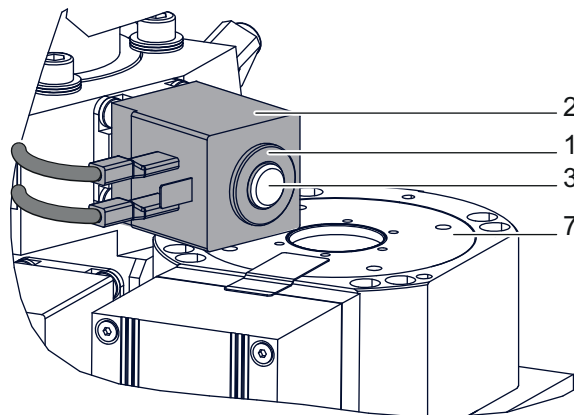

Fig. 20: Dismantling the coil

### 5.6.3 Replacing the operating fluid reservoir



#### WARNING

**Risk of intoxication in case of contact with substances hazardous to health.**

Always take appropriate precautions when handling the operating fluid reservoir:

- Dispose of operating fluid reservoirs in accordance with the applicable legislation. Safety data sheet available upon request or at [www.pfeiffer-vacuum.com](http://www.pfeiffer-vacuum.com)
- Take the required safety precautions to avoid creating health risks or polluting the environment in case of contamination.
- Decontaminate the parts affected before performing maintenance work.



#### Operating fluid filling

The operating fluid reservoir is sufficiently filled with operating fluid.

- Do not add additional operating fluid.

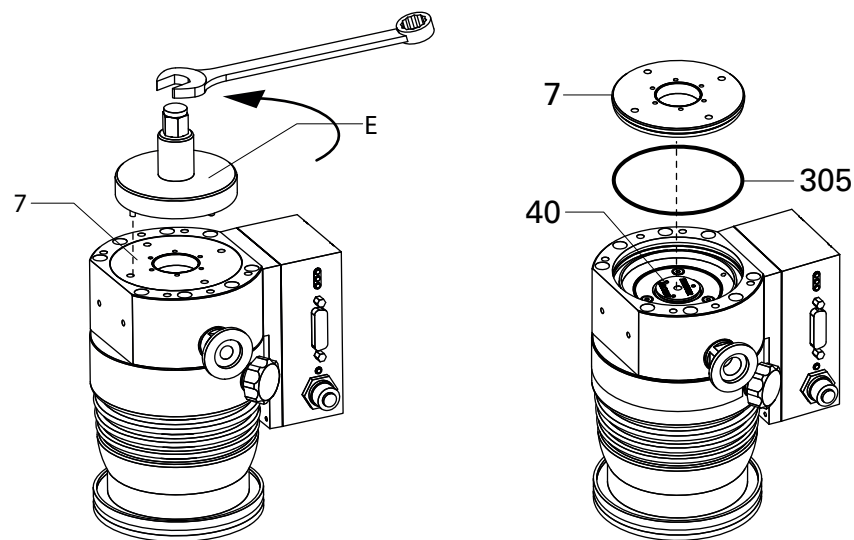

**Fig. 21: Assembly / Disassembly of the operating fluid reservoir**

7	End cover	40a	Porex rod	305	O-ring
40	Operating fluid reservoir	40c	O-ring	E	Key for end cover

- Screw out the end cover 7 on the bottom of the turbopump with special tool E. Pay attention to O-ring 305.

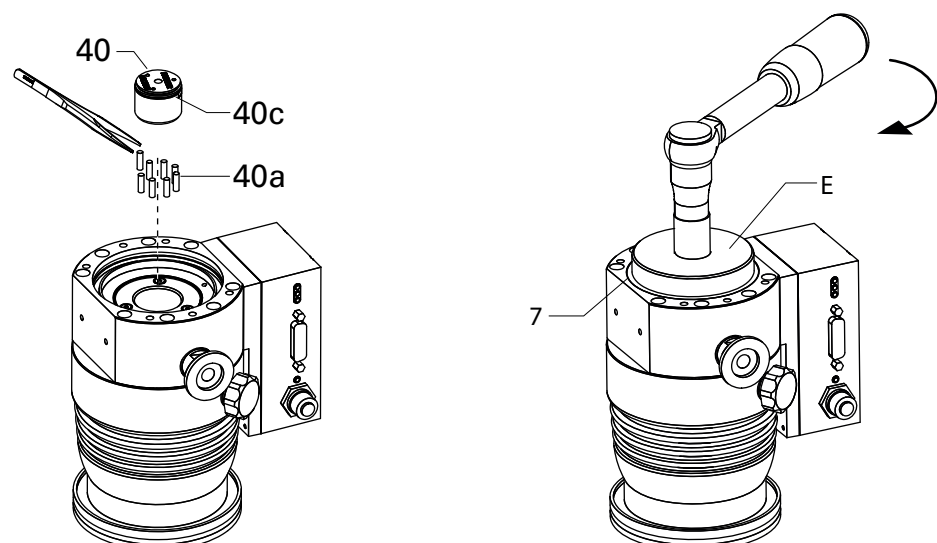

- Lift out the operating fluid reservoir using two screwdrivers.

- Using tweezers, pull out Porex rods (8 pieces).
- Remove impurities from the turbopump and the end cover with a clean, lint-free cloth.  
**Do not use any cleaning fluids!**
- Using tweezers, insert new Porex rods (8 pieces).
- Push the new operating fluid reservoir up to the O-ring 40c into the pump.
  - **Do not** perform any pressure upon the operating fluid reservoir!
- Screw in the end cover with the new O-ring 305. The operating fluid reservoir is brought into the correct axial position by the end cover.
- Observe the end cover's tightening torque **13 Nm ± 10 %** .

## 5.7 Pirani gauge maintenance

### 5.7.1 Replacement

- |                               |  |
|-------------------------------|--|
| <b>Tools/<br/>Spare parts</b> | <ul style="list-style-type: none"> <li>• CHc M4 x 80 screw supplied in the maintenance kit</li> <li>• 3 mm Allen key supplied in the maintenance kit</li> <li>• Gauge (see 9)</li> </ul> |
|-------------------------------|--|

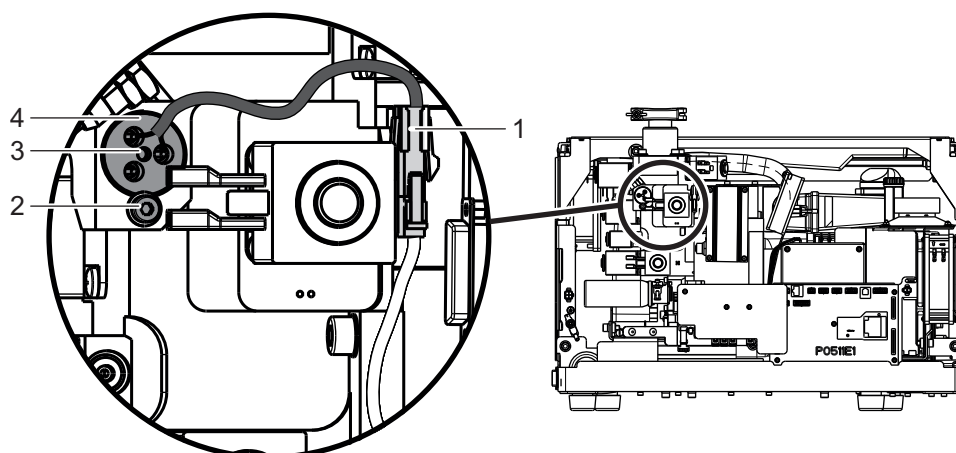

Fig. 22: Gauge maintenance

- Remove the front cover of the detector (see 5.2.1).
- Disconnect the gauge harness (1).
- Loosen the retainer screw (2).
- Tighten the CHc screw (3) in the center of the gauge.
- Pull on the CHc screw (3) to free the gauge.
- Position the new gauge (4).
- Tighten the retainer screw (2).
- Connect the gauge harness (1).
- Adjust the gauge: see chapter **Internal Pirani gauge calibration** in the *Operating Instructions*.

## 5.8 Fan maintenance

### 5.8.1 Location

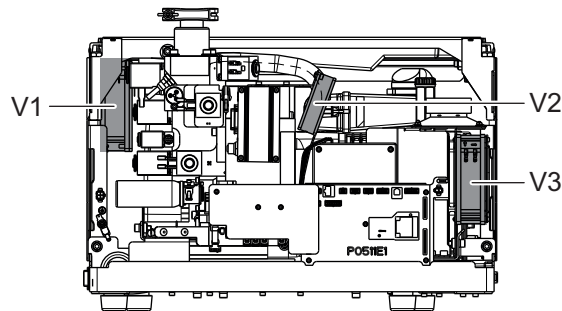

Fig. 23: Fan location

V1	Air inlet fan
V2	Turbomolecular pump fan
V3	Air Exhaust fan

- |                               |  |
|-------------------------------|--|
| <b>Tools/<br/>Spare parts</b> | <ul style="list-style-type: none"> <li>• Philips screwdriver</li> <li>• Fan + grill (see 9)</li> </ul> |
|-------------------------------|--|

### 5.8.2 Replacement of the air inlet fan

- Remove the front and rear cover of the detector (see 5.2).
- Remove the air filter of the rear cover.

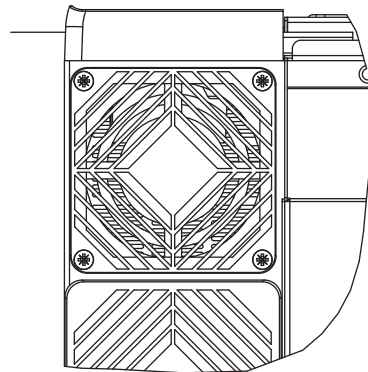

Fig. 24: Maintenance of the air inlet fan

- Disconnect the harness (1) of the fan (V1)
- Loosen the 4 fixing screws (2). Keep the 4 metal hooks (4) of the old fan.
- Attach the grill (3) to the unprotected side of the new fan. Fit the 4 metal hooks (4) onto each angle of the fan.
- Position the fan, respecting the direction arrows.
- Fit the fan and attach the unit using the 4 fixing screws.
- Connect the fan harness (1), respecting the (+) and (-) polarities.

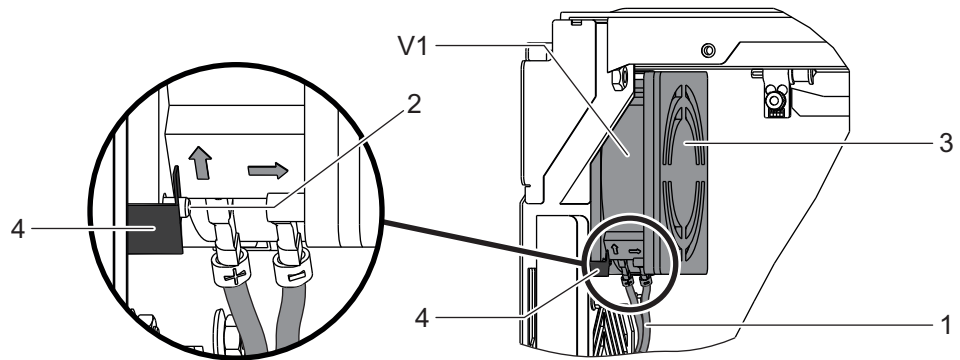

Fig. 25: Placing of fan and harness

### 5.8.3 Replacement of the turbomolecular pump fan

- Remove the front cover of the detector (see 5.2.1).
- Disconnect the fan harness (1) of fan (V2) from the 24V distribution board (2).
- Loosen the 2 fixing screws (3).
- Replace the fan, respecting the correct direction.

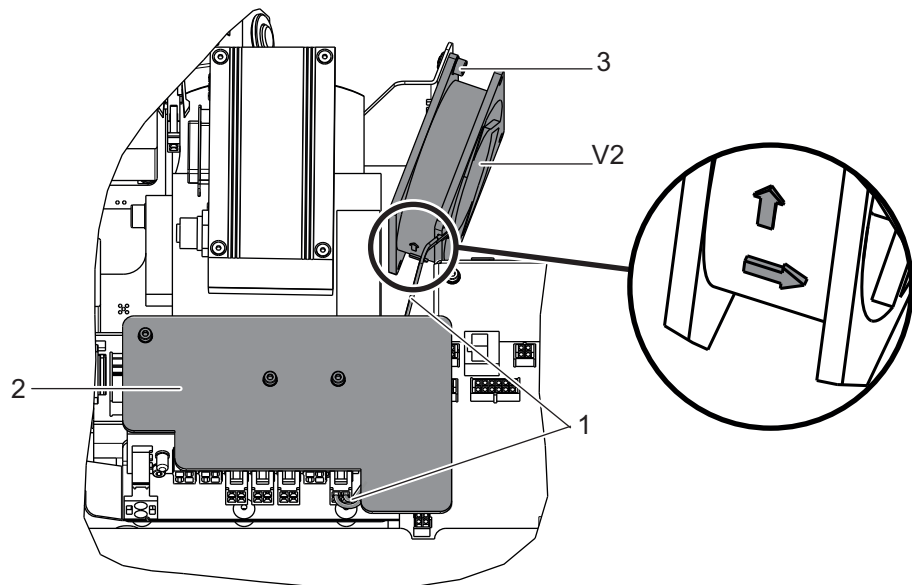

Fig. 26: Maintenance of the turbomolecular pump fan

### 5.8.4 Replacement of the exhaust fan

- Remove the front cover (see 5.2.1).
- Disconnect the fan harness (1) of the fan (V3).
- Loosen the 4 fixing screws (+ 2 washers per screw).
- Replace the fan, respecting the direction arrows.
- Position the protective grill (2) and attach the unit using the 4 fixing screws (+ 2 washers per screw).
- Connect the fan harness (1), respecting the (+) and (-) polarities.



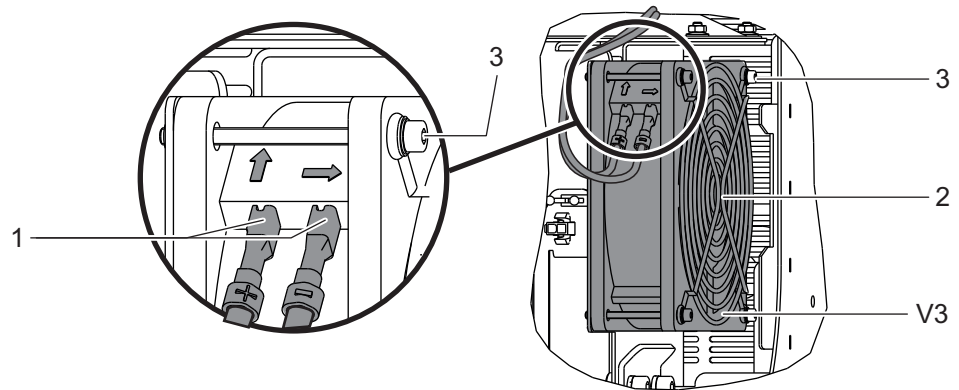

Fig. 27: Maintenance of the exhaust fan

## 5.9 Air filters maintenance

### 5.9.1 Air filters location

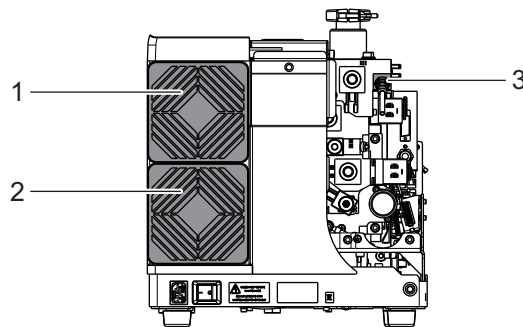

Fig. 28: Air filters location

1	Air filter no. 1
2	Air filter no. 2
3	Air filter of the vacuum block

#### Tools/Spare parts

- 13 mm and 17 mm spanners (for the air filter of the vacuum block)
- Air filters (see 9)

### 5.9.2 Replacement of air filters no. 1 and no. 2

- Unclipping the air filter.
- Replacing the used filter: follow the assembly order indicated below (1 + 2 + 3: **do not forget the grill**).

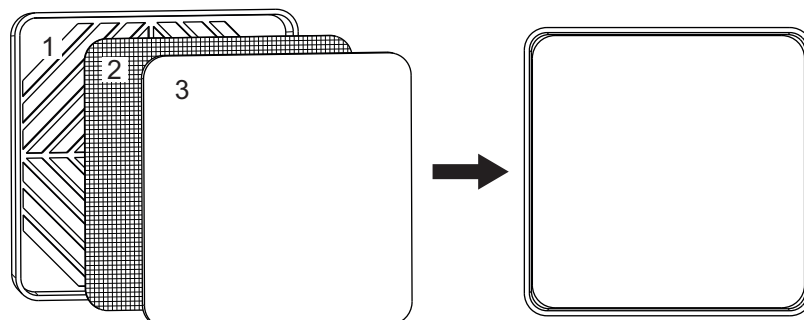
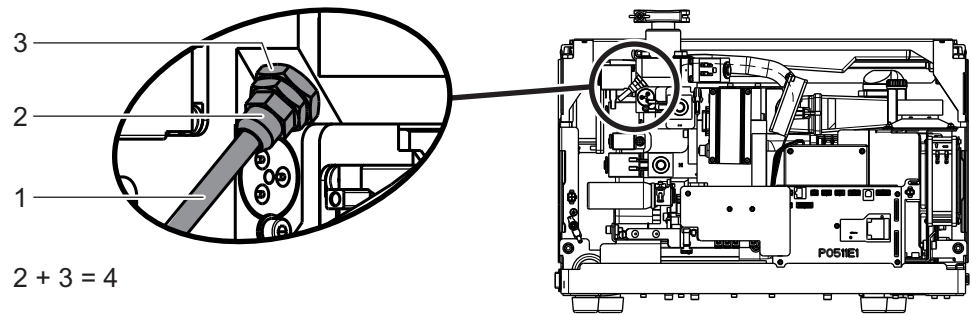

Fig. 29: Air filter assembly

- Clipping the entire air filter.

### 5.9.3 Replacement of the vacuum block air filter



**Fig. 30: Maintenance of the vacuum block air filter**

- Remove the front cover (see 5.2.1).
- Loosen the filter connector (2) with the 13 mm spanner to free the tube (1).
- Loosen the connector (3) with the 17 mm spanner.
- Loosen the connector (2) of the new filter (4).
- Install the new filter in reverse dismantling order and tighten the connectors.

## 6 Shutdown

### 6.1 Prolonged downtime

If the detector must be shut down for an extended period of time, after use it is recommended that you:

- apply the prolonged downtime procedure described in the **Prolonged storage** chapter of the *Operating Instructions*.
- keep the detector in its original packaging or under its protective cover in a dust-free environment.
- for the start-up procedure, see **Operation** of the *Operating Instructions*. If a problem occurs, contact your Pfeiffer Vacuum service center.

### 6.2 Disposal



**In accordance with the 2002/96/EC Directive on the treatment of waste electrical and electronic equipment, and the 2011/65/EC Directive on the restriction of hazardous substances, adixen's end-of-life products will be returned to the manufacturer for decontamination and recovery purposes.**

The manufacturer's obligation to recover this equipment applies only to complete items of equipment which have not been modified or retrofitted, using only spare parts from adixen Vacuum Products, sold by Pfeiffer Vacuum and including all their assemblies and sub-assemblies.

This obligation does not cover the product shipping costs to a treatment facility or the service itself which will be charged to the customer.

Before you return a product to our service centres, please familiarise yourself with the after-sales service procedure, and complete the declaration of contamination available on our website.



#### WARNING

##### Environmental protection

The product or its components must be disposed of in accordance with the applicable regulations relating to environmental protection and human health, with a view to reducing natural resource wastage and preventing pollution.

Our products contain different materials which must be recycled: iron, steel, stainless steel, cast iron, brass, aluminium, nickel, copper, PTFE, FEP.

Special precautions must be taken for components in contact with the products resulting from potentially contaminated processes.

# 7 Malfunction

## 7.1 What happens in case of a fault

The leak detector can display warnings or faults on screen at any time.

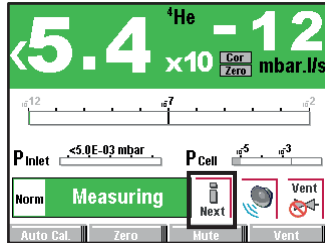

Fig. 31: Standard screen with warning [i Next]

### 7.1.1 Warning / fault display

Press the key to display the fault.

1	Level 1: Warning Press the [i Next] key to display the maintenance information	
2	Level 2: Major fault: erroneous measurement Press the [i Next] or [!] key to display the fault.	
3	Level 3: Critical fault: test impossible Press the [i Next] or [!] key to display the fault.	
5	Level 5: Warning The detector is not in normal operating condition. Press the [i Next] or [i] key to display the fault.	

### 7.1.2 Warning / fault window

Description

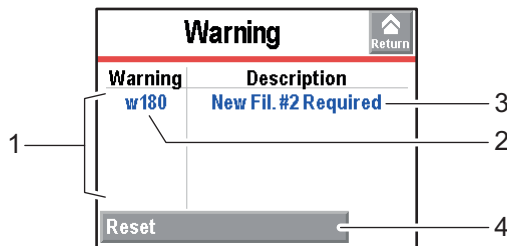

Fig. 32: Warning/fault window

1	Fault list: 5 maxi.
2	RS 232 fault code.
3	Fault description.
4	Warning and faults deletion: faults requiring the operator's intervention remain displayed as long as the cause of the fault has not been corrected.

### 7.1.3 List of warnings / faults

Level	RS Order	RS 232 Code	Information
1	?ER	e59	calib. test mode lost
	?ER	e93	Dynamic Calib. Fail
	?WA	w145	maintenance required
	?WA	w150	primary pump maint
	?WA	w160	high. vac pump maint
	?WA	w180	new fil#2 required
	?WA	w181	new fil#1 required
	?WA	w211	manual calibration
	?WA	w220	Filament Request Off
	?WA	w235	auto. cal. required.
2	?ER	e50	cell. zero stability
	?ER	e57	lack of sensitivity
	?ER	e58	sensitivity too high
	?ER	e65	background too high
	?ER	e80	cal. leak year erro
	?ER	e85	Temperature Too High
	?ER	e89	emission lost
	?ER	e95	cell. zero off limits
	?ER	e97	temperature too high
	?ER	e98	temperature too low
3	?ER	w241	auto. cal. required
	?ER	w244	VHS uncalibrated
	?ER	e56	background trouble
	?ER	e70	peak adjust error
	?ER	e188	high. vac pump speed
	?ER	e192	Fil Current Too High
	?ER	e194	fil2-collector short
	?ER	e195	fil1-collector short
	?ER	e205	Primary pump failure
	?ER	e206	ACP Temp. Too High
	?ER	e210	Primary Pump Failure
	?ER	e220	No collector voltage
	?ER	e224	- 15 V cell. failure
	?ER	e230	filaments #1&#2 bad
	?ER	e235	cell pres.>1e-03 mbar
	?ER	e238	no cell com.
	?ER	e239	No High Vac Pump com
	?ER	e241	high. vac pump speed
	?ER	e243	EEPROM error
	?ER	e245	high. vac pump fail
?ER	e247	check ATH connector	
?ER	e248	check MDP connector	
?ER	e251	+ 15 V cell failure	
?ER	e252	24 V cell failure	
?ER	e253	time keeper ram fail.	
5	?ER	e96	Autocal failure +2 <sup>nd</sup> code
	?ER	e99	24 V DC troubles
	?ER	e255	An error occurred +2 <sup>nd</sup> code
	?WA	W97	temperature too high
	?WA	W98	temperature too low
	?WA	W230	auto. cal. required
	?WA	W255	Out start condition

## 7.2 Troubleshooting guide

The troubleshooting guide helps correct the malfunctions reported on the detector's control panel or affecting the detector. It can be consulted from an interactive application specifically developed for the technical documentation.

### 7.2.1 Installation of the application

- Insert the Operating Manual CDRom into the CD/DVD player of the computer.
- Launch the "ASM340" application.
- Select the language.
- Select the interactive application '**Troubleshooting**'.
- Install the application on your computer.



Fig. 33: Selection of the interactive application

### 7.2.2 Consultation of the application



**Create a shortcut on the computer desktop for direct access to the 'Troubleshooting' application.**

- Launch the '**Troubleshooting**' application.
- Select the navigation language (1).
- Select the product and the appropriate key word (2).
- Launch the search (3).
- Select a symptom (4): the origin and diagnosis of this symptom are displayed (5).

The screenshot shows the Pfeiffer Vacuum troubleshooting interface. At the top, there is a red header with the 'adi:ten' logo and a 'Troubleshooting' button. Below the header, a search bar is highlighted with a red box and labeled '1'. To the left, a sidebar contains filter options for 'Product' (set to 'K300 300'), 'Message', and 'Background', with a 'Search' button below them. The main area displays search results, with the first result highlighted in red and labeled '4'. Below this, a table titled 'Background of 1x10-12 mbar J0' provides diagnostic information. The table has two columns: 'Origin / Diagnosis' and 'Solution'. Two entries are listed, both with the same origin and diagnosis: '000 Bad adjustment of the electronic zero.' The solutions are 'Launch an auto-calibration.' and 'Start again the detector.'. A 'Print' button is located at the bottom right of the table. At the bottom of the page, there is a footer with the text 'Default not defined? Contact your service center: info@pfeffer-vacuum.de'.

Origin / Diagnosis	Solution
000 Bad adjustment of the electronic zero.	Launch an auto-calibration.
000 Bad adjustment of the electronic zero.	Start again the detector.

## 8 Service

### **Pfeiffer Vacuum offers first-class customer service!**

- On-Site maintenance for many products)
- Overhaul / repair in the nearby Service Location
- Fast replacement with refurbished exchange products in mint condition
- Advice on the most cost-efficient and quickest solution

Detailed information, addresses and forms at: [www.pfeiffer-vacuum.com](http://www.pfeiffer-vacuum.com) (Service).

### **Overhaul and repair in the Pfeiffer Vacuum Service Center**

The following general recommendations will ensure a fast, smooth servicing process:

- ➔ Fill out the "Service Request/Product Return" form and send it to your local Pfeiffer Vacuum Service contact.
- ➔ Include the confirmation on the service request from Pfeiffer Vacuum with your shipment.
- ➔ Fill out the declaration of contamination and include it in the shipment (mandatory!). The Declaration of contamination is valid for any product/device including a part exposed to vacuum.
- ➔ Dismantle all accessories and keep them.
- ➔ Close all the ports flange openings by using the original protective covers or metallic airtight blank flanges for contaminated devices.
- ➔ If possible, send pump or unit in its original packaging.

### **Sending of contaminated pumps or devices**

No devices will be accepted if they are contaminated with micro-biological, explosive or radioactive substances. "Hazardous substances" are substances and compounds in accordance with the hazardous goods regulations (current version).

- ➔ Neutralize the pump by flushing it with nitrogen or dry air.
- ➔ Close all openings airtight.
- ➔ Seal the pump or device in suitable protective film.
- ➔ Return the pump/device only in a suitable and sturdy transport container and send it in while following applicable transport conditions.

Pump or device returned without declaration of contamination form fully completed and/or non-secured in a suitable packaging, will be decontaminated and/or returned at the shipper's expense.

### **Exchange or repaired**

The factory operating parameters are always preset with exchange or repaired devices. If you use specific parameters for your application, you have to set these again.

### **Service orders**

All service orders are carried out exclusively according to our general terms and conditions for the repair and maintenance, available in our website.



## 9 Spare parts

### 9.1 Ordering information

Spare parts available for sales, classified by functions are listed in this chapter.

<b>Function</b>	<b>See following pages</b>
Tool	<b>F100</b>
Monitoring and Display	<b>F200</b>
Power and electrical supply	<b>F300</b>
Automatic control system and electronic circuits	<b>F400</b>
Measurement	<b>F500</b>
Pumping	<b>F600</b>
Vacuum block	<b>F700</b>
Pipes - Connections - Seals	<b>F800</b>
Cover	<b>F900</b>
ASM 340 specific accessories	<b>F1000</b>

## Tools ASM 340



**Accessoires de raccordement**  
Connection accessories  
Verbindungzubehör



**Fuites calibrées Helium**  
Helium calibrated leaks  
Helium Testleck

**A037**

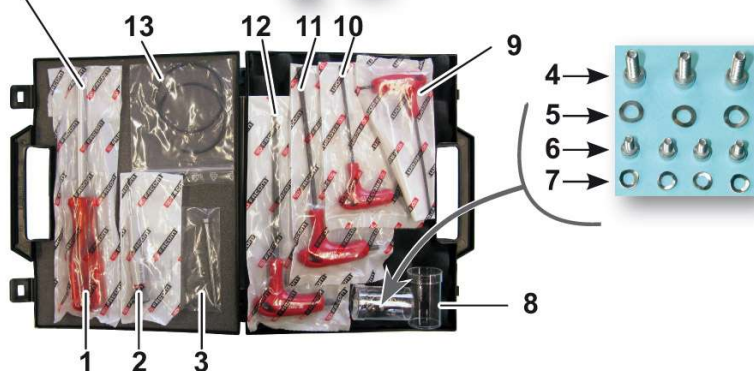

Rep. Ref. / Teil	Qté / Menge	Désignation / Designation / Beschreibung
1	1	<b>Clé emmanchée</b> Box-shank nut spinner Rohrsteckschlüssel mit Heft
2	1	<b>Tournevis pour vis TORX® 6X35</b> Screwdriver for TORX® screw 6x35 Handschrauben für TORX® Schrauben 6x35
3	1	<b>Vis CHc M 4x80</b> Screw CHc M 4x80 Edelstahlschraube CHc M 4x80
4	4	<b>Vis CHc M 4x12</b> Screw CHc M 4x12 Edelstahlschraube CHc M 4x12
5	5	<b>Rondelle</b> Washer Unterlegscheibe
6	3	<b>Vis CHc M 3x6</b> Screw CHc M 3x6 Edelstahlschraube CHc M 3x6
7	3	<b>Rondelle</b> Washer Unterlegscheibe
8	1	<b>Fusible 5 x 20 F1 6,3 A</b> Fuse 5 x 20 F1 6,3 A Sicherung 5 x 20 F1 6,3 A
9	1	<b>Clé six pans mâle de 2,5 mm</b> Innensechskantschlüssel 2,5 mm
10	1	<b>Clé six pans mâle de 3 mm</b> Innensechskantschlüssel 3 mm
11	1	<b>Clé six pans mâle de 4 mm</b> Innensechskantschlüssel 4 mm
12	1	<b>Clé six pans mâle de 5 mm</b> Innensechskantschlüssel 5 mm
13	1	<b>Joint cellule d'analyse 3G</b> 3G Analyser cell O ring 3G Zelle Dichtung

Ref	Description	P/N	Qty	Remarks
A006	DN16KF Calibrated Leak Adaptator Kit	110715	1	
A007	DN25KF Calibrated Leak Adaptator Kit	110716	1	
A013	Tee, Reducing - DN25/25/16KF	068269	1	
A016	Calib. Leak With Valve 1-3.10-6 DN25KF	FV4610	1	
A020	Clamp DN20/25KF	083264	1	
A024	Centering Ring SS/Per DN25KF	068189	1	
A025	Funnel	067592	1	
A027	Vacuum Silicon Grease (100 g Box)	064600	1	
A036	3G Cell, Analyzer Chamber Transport	114386	1	
A037	3G Detection maintenance Kit	114718	1	
A040	"Brucelles" Tweezers	115396	1	

Monitoring and display  
ASM 340

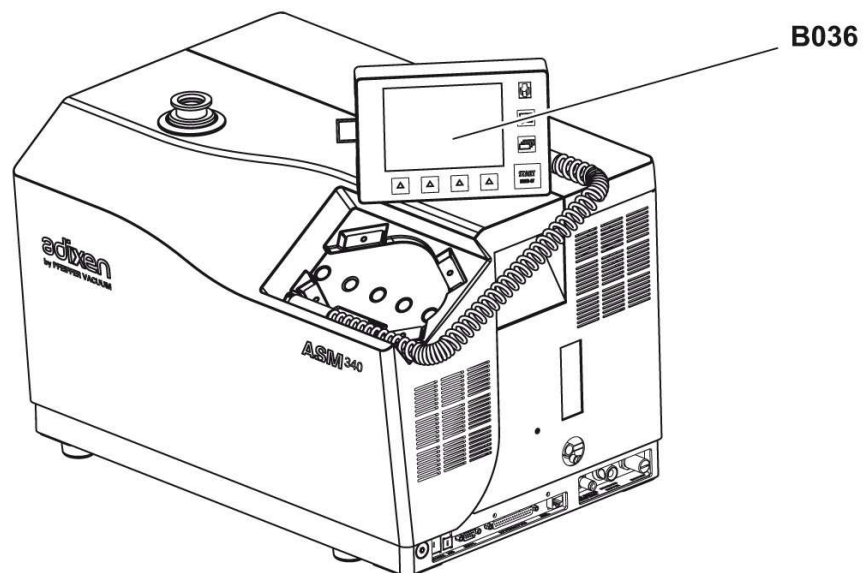

Ref	Description	P/N	Qty	Remarks
B036	Control Panel (Black) - 340	121557S	1	

## Power and electrical supply ASM 340

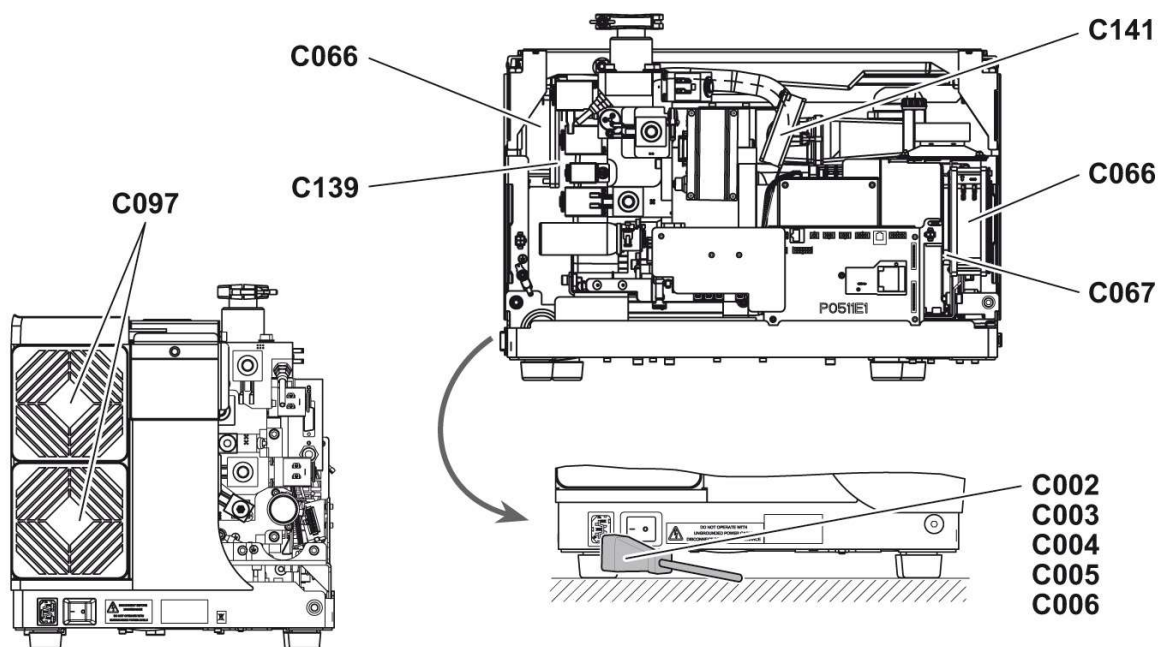

Ref	Description	P/N	Qty	Remarks
C002	Cable, Main Power; 2 m - Italy	104758	1	
C003	Cable, Main Power; 2 m - Switzerland	103718	1	
C004	Cable, Main Power; 2 m - UK	104411	1	
C005	Cable, Main Power; 2 m - USA	103567	1	
C006	Cable, Main Power; 2 m - France/Germany	103566	1	
C066	Fan - 20MD/182/192/340	101094	1	
C067	Fan Grill 120x120 mm (101094))	056067	1	
C097	Grille + Filter for Fan - ASI20/22	104754	1	
C139	Protection grill 120x120 mm	104753	1	
C141	Fan 80x80x25 mm - 340	121658	1	

## Automatic control system and electronic circuits ASM 340

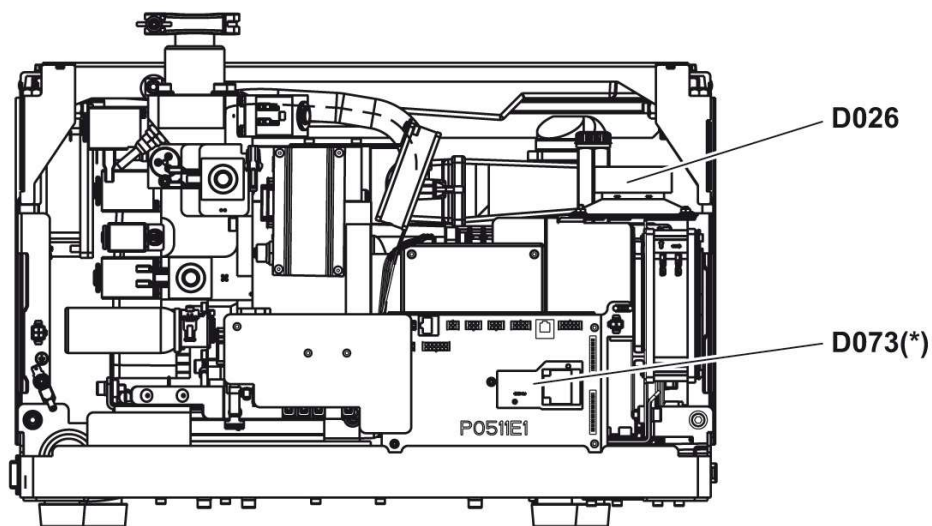

(\*) Option/Accessoire - Option/Accessory - Option/Zubehör

Ref	Description	P/N	Qty	Remarks
D026	Loudspeaker; 90 DB/D 10 cm	060097	1	
D073	P0482E1 Bluetooth Board	P0482E1	1	

## Measurement ASM 340

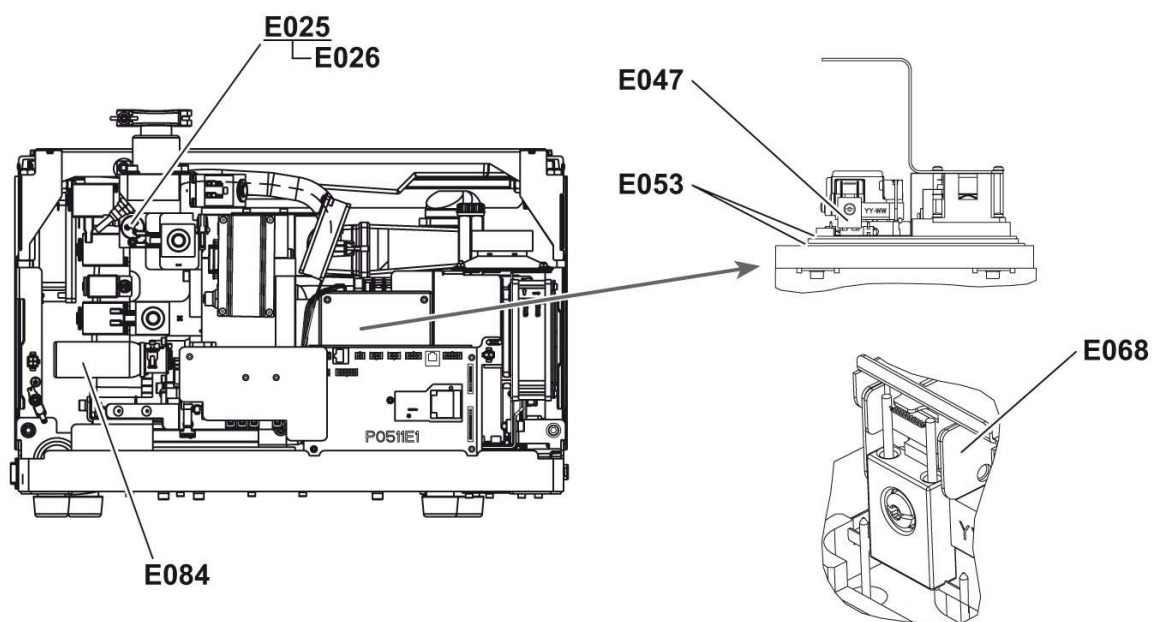

Ref	Description	P/N	Qty	Remarks
E025	Gauge, PI1 (Aluminium)	795706	1	
E026	Filament for PI1 Gauge	057972	1	
E047	Filament for 3G Analyzer Cell	114864S	1	
E068	3G.2 Cell ExtrACTION Electrode - Service	119641	1	
E084	Calibrated Leak, Internal - 340	121528S	1	

## Pumping ASM 340

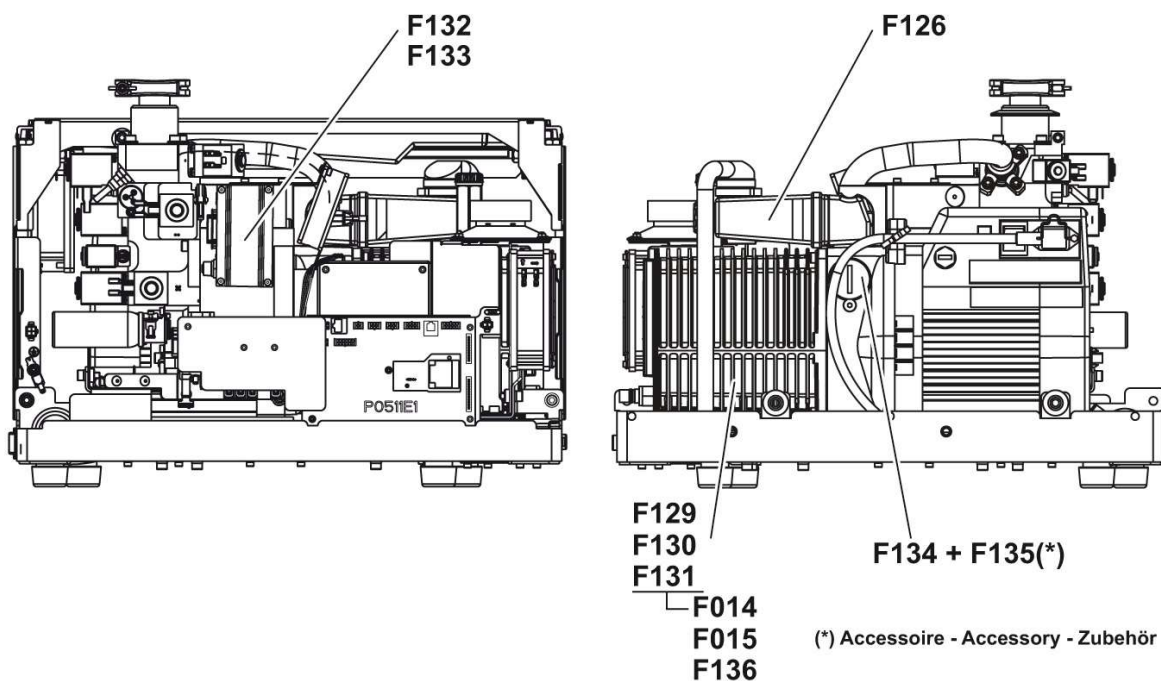

Ref	Description	P/N	Qty	Remarks
F014	Oil, A200 (1L)	068694	1	
F015	Funnel	067592	1	
F126	Oil mist Eliminator 21 m3/h D30 mm - 340	121494	1	
F132	Oil reservoir for Splitflow 50 - 340	PM 143 740 -T	1	
F133	Special wrench for oil reservoir - 340	PV M40 813	1	
F134	Exhaust connector - 340 Wet	A464061	1	Order Ref. F134 and Ref. F135 simultaneously
F135	O'Ring 3.6 x 29.3 FPM	082025	1	Order Ref. F134 and Ref. F135 simultaneously
F136	Draining connector - 340 Wet	107646	1	

## Vacuum block ASM 340

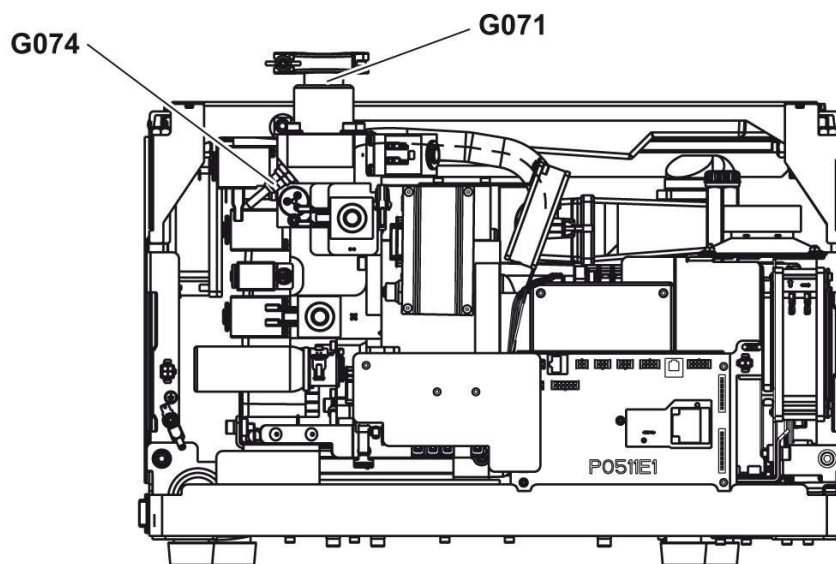

Ref	Description	P/N	Qty	Remarks
G071	Inlet port filter - 340	103395	1	
G074	Vacuum block filter - 340	122237	1	



## Pipes - Connections - Seals ASM 340



Ref	Description	P/N	Qty	Remarks
H165	O'Ring 3.6 x 29.3 FPM	082025	1	
H166	Vacuum block filter - 340	122237	1	
H170	Draining connector - 340 Wet	107646	1	

## Cover ASM 340

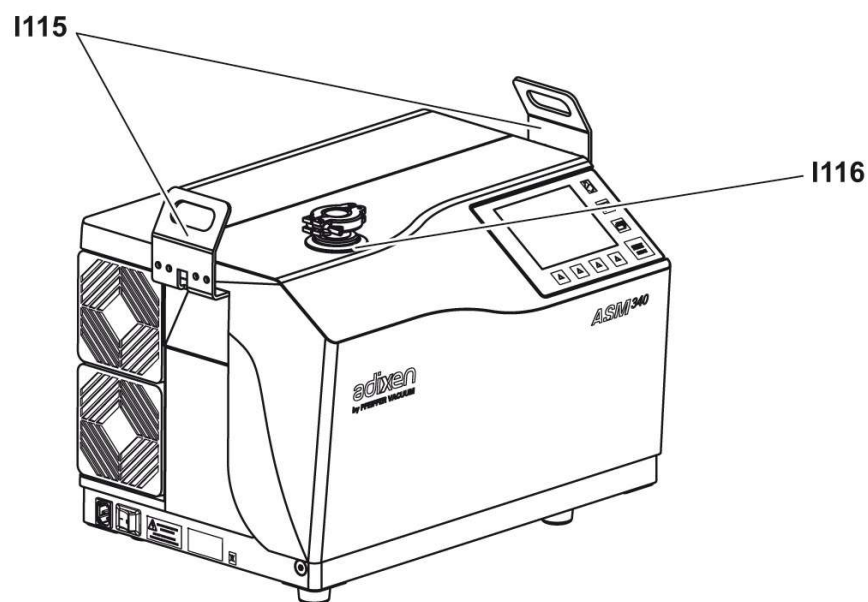

Ref	Description	P/N	Qty	Remarks
I114	Protection cover - 340	A006733	1	
I115	Lifting handle - 340	A333918	1	
I116	DN25KF Inlet Pipe Frame - 340	A334286	1	

## Options and accessories ASM 340

Filtres d'entrée  
Inlet filters  
Eingang Filters

J175  
J176  
J177  
J178  
J179  
J180



J181  
J182  
J183



J077  
J078



J174

Ref	Description	P/N	Qty	Remarks
J077	20 µm Poral Filter D 114 mm	105847	1	
J078	5 µm Poral Filter D 114 mm	105848	1	
J174	O'ring Ø 5 mm - D 114 mm	082152	1	
J175	20 µm Poral Filter DN25/25 KF	105841	1	
J176	20 µm Poral Filter DN40/40 KF	105842	1	
J177	20 µm Poral Filter DN40/25 KF	105843	1	
J178	5 µm Poral Filter DN25/25 KF	105844	1	
J179	5 µm Poral Filter DN40/40 KF	105845	1	
J180	5 µm Poral Filter DN40/25 KF	105846	1	
J181	SS mesh filter 70 µm DN16 KF	072721	1	
J182	SS mesh filter 70 µm DN25 KF	072857	1	
J183	SS mesh filter 70 µm DN40 KF	067636	1	

## Options and accessories ASM 340

**Accessoires divers**  
Miscellaneous accessories  
*Verschiedenes-Zubehören*



Ref	Description	P/N	Qty	Remarks
J185	RC 500 WL remote control -340	PT 445 432 -T	1	
J186	Cable transmitter/ASM340 - RC500WL	A466613	1	
J187	Cable remote/ASM340 - RC500WL	A465975	1	
J188	Bypass Kit Europe - 340	PT 445 411 -T	1	
J189	Bypass Kit US - 340	PT 445 413 -T	1	
J190	Bypass kit cable - 340	A465982	1	
J191	Gauge cable 3 m - 340	A333746	1	
J192	Gauge cable 10 m - 340	A333747	1	
J193	Gauge cable 20 m - 340	A333748	1	

**Vacuum solutions  
from a single source**

Pfeiffer Vacuum stands for innovative and custom vacuum solutions worldwide, technological perfection, competent advice and reliable service.

**Complete range  
of products**

From a single component to complex systems: We are the only supplier of vacuum technology that provides a complete product portfolio.

**Competence in  
theory and practice**

Benefit from our know-how and our portfolio of training opportunities! We can support you with your plant layout and provide first-class on-site-service worldwide.

**Are you looking for a  
perfect vacuum solution?  
Please contact us**

**Pfeiffer Vacuum GmbH**  
Headquarters  
T +49 6441 802-0  
info@pfeiffer-vacuum.de



Ed 01 - Date 2013/06 - P/N:121762MEN