

XtraDry™



**The pump that always stays “clean.”
For clean and reliable processes.**

**Absolutely “dry” and oil-free!
Innovative engineering without particle emissions.**

PFEIFFER  **VACUUM**

Innovative by design!

The two-stage piston vacuum pump XtraDry™.

A high volume flow rate independent of the type of gas combined with low final pressures down to < 0.05 mbar – these are performance benefits which are attained here with only two cylinders!

The clever crankshaft design in connection with the frequency independent drive ensures extremely low noise and low vibration operation.

The innovative piston/cylinder design ensures not only operation which is absolutely free of hydrocarbons but also reliably avoids particle emissions. Simultaneously, the unique piston design prevents sudden inrushes of atmospheric air when the pump is at standstill.

In all, an extremely clean design!

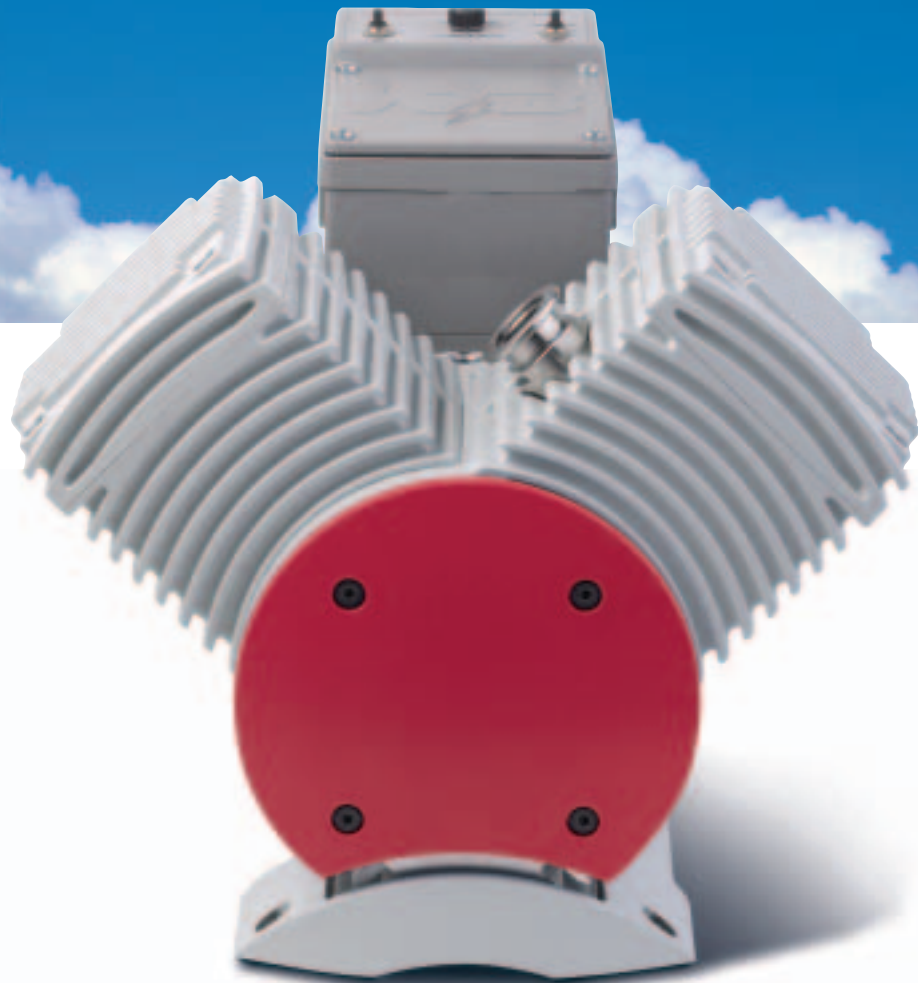

The benefits at a glance:

Particle-free

- ▶ No process contamination
- ▶ No particle emissions
- ▶ Soft-start mode eliminates turbulence

Oil-free

- ▶ Absolutely dry pump chamber
- ▶ No hydrocarbons on the intake side
- ▶ No oil within the entire pump body

Strong performance

- ▶ High volume flow rate independent of the type of gas

Low vibration levels

- ▶ Precisely tuned running characteristic for extremely quiet operation

Flexible

- ▶ Standby mode increases service life
- ▶ Speed matching in connection with Pfeiffer Vacuum turbomolecular pumps for ideal adaptation to the process
- ▶ Frequency converter operation is independent of the mains frequency

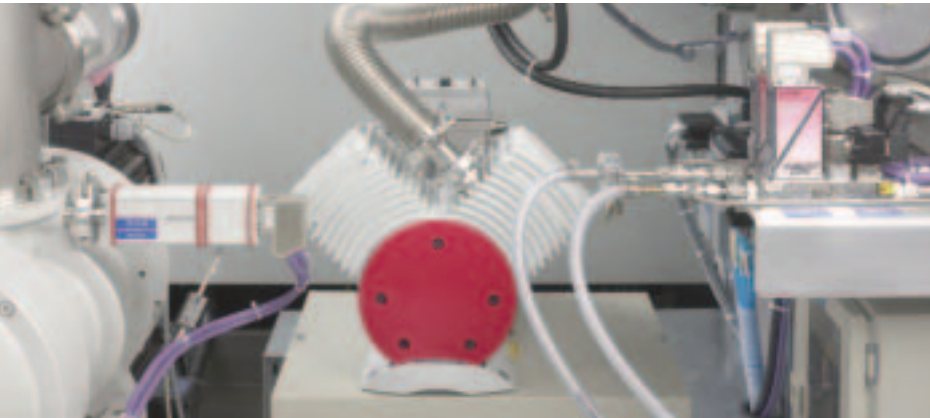

XtraDry™ 250-1 as a differential loadlock pump system on a coater.



XtraDry™ 150-2 as a high throughput backing pump within a leak detection module.

A pump concept for all rough and medium vacuum applications

The ideal backing pump for high vacuum pumps, for example, turbomolecular pumps from Pfeiffer Vacuum

Analytical systems

- ▶ Mass spectrometers
- ▶ Leak detectors
- ▶ Electron microscopy

Medical technology

- ▶ Sterilization
- ▶ Vacuum packaging

Industry

- ▶ Lamp and tube production
- ▶ Coating

Further applications

- ▶ Robotics
- ▶ Differential sealing systems

Dimensions in millimeters

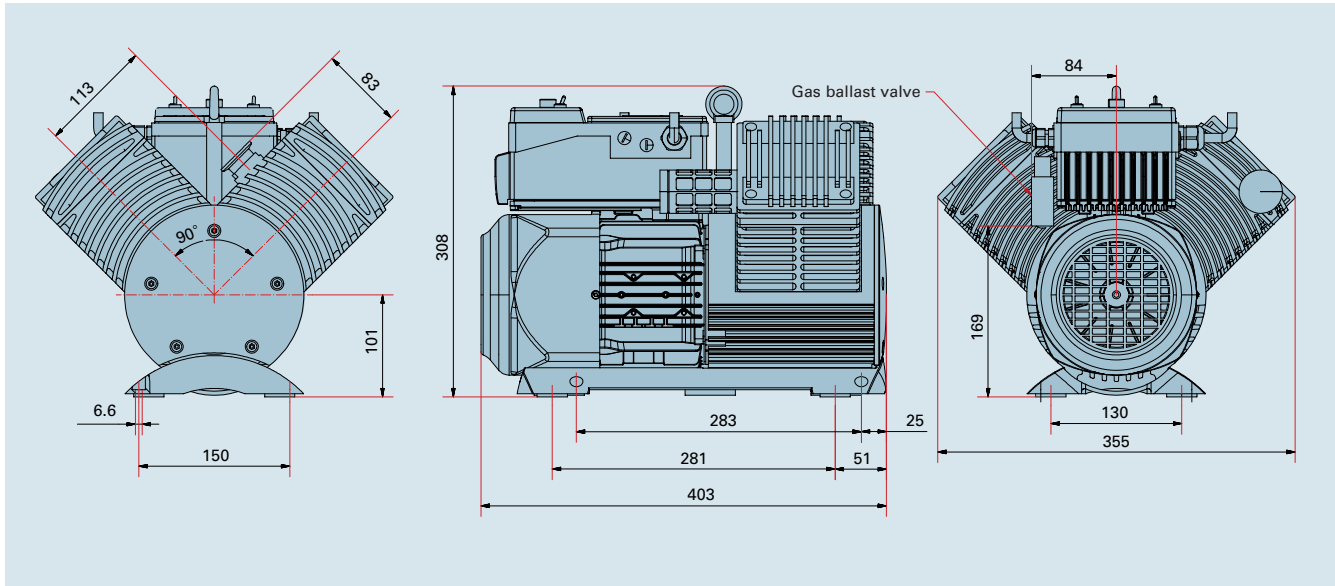

Volume flow rate

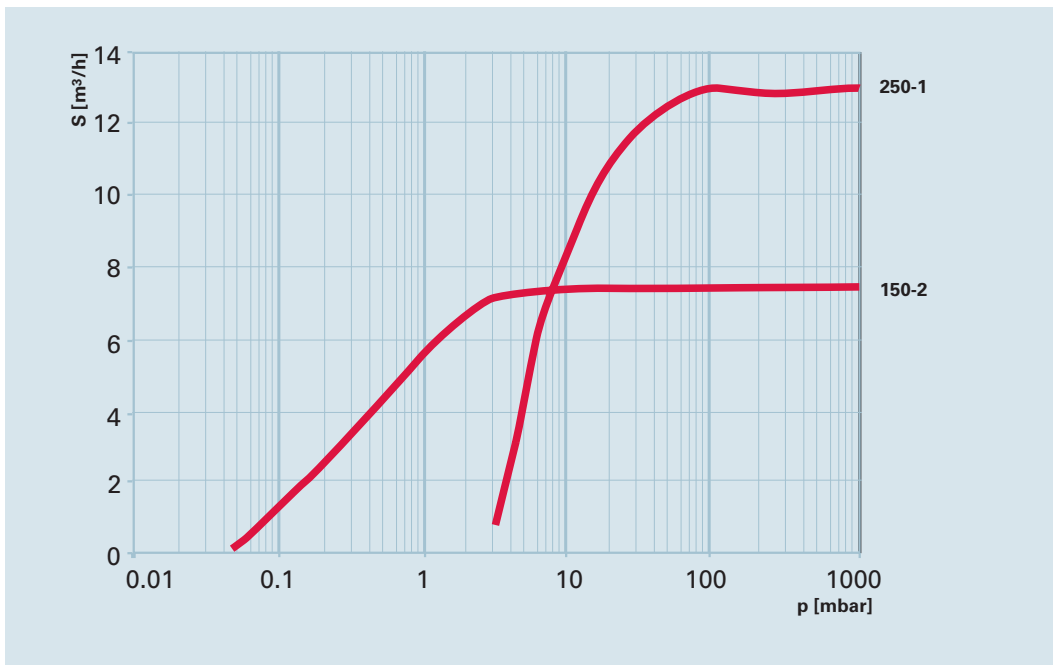

Technical data

Reciprocating piston pump		XtraDry™ 150-2	XtraDry™ 250-1
Connection flange	Inlet	DN 25 KF	DN 25 KF
	Exhaust	DN 25 KF/ 1/2"	DN 25 KF/ 1/2"
Final pressure		< 0.05 mbar (< 0.04 Torr)	< 4 mbar (< 3 Torr)
Nominal flow rate		7.5 m³/h (< 4.5 CFM)	13 m³/h (< 8 CFM)
Maximum exhaust pressure		1.1 bar (< 830 Torr)	1.1 bar (< 830 Torr)
Leak rate		< 0.01 mbar l/s (< 0.5 sccm)	< 0.01 mbar l/s (< 0.5 sccm)
Nominal motor rating		550 W	550 W
Noise level		≤ 58 dB(A)	≤ 58 dB(A)
Ambient temperature		12 – 40 °C	12 – 40 °C
Weight		29 kg	29 kg

Ordering numbers

Reciprocating piston pump	XtraDry™ 150-2	XtraDry™ 250-1
Mains connection: Voltage (range) 230 V +/- 10 %, 50/60Hz	PO P01 050	PO P01 060
Mains connection: Voltage (range) 115 V +/- 10 %, 50/60Hz	PO P01 051	PO P01 061

Options

TCX 010, speed control for XtraDry™ ¹⁾	PO 003 307-X	PO 003 307-X
TCX 020, speed control for XtraDry™ ²⁾	PO 003 363-X	PO 003 363-X
Connection cable, XtraDry™, length 1 m	PO 003 346	PO 003 346
Connection cable, XtraDry™, length 3 m	PO 003 347	PO 003 347

¹⁾ In combination with Pfeiffer Vacuum turbomolecular pumps with drive electronics TC 600/750

²⁾ In combination with Pfeiffer Vacuum turbomolecular pumps with drive electronics TCP 350



Pfeiffer Vacuum – Your Vacuum Technology Experts™



For over 100 years, we have been setting milestones in vacuum technology through our comprehensive line ranging from individual components to complex vacuum systems.

Quality and service worldwide from the inventor of the turbomolecular pump. We are the world's market leader with over 250,000 turbomolecular pumps sold.

You have questions concerning your vacuum application? Ask Pfeiffer Vacuum.



Consulting and Service Worldwide

- ▶ Worldwide on-site service
- ▶ Sophisticated logistics concept
- ▶ Individual service contracts
- ▶ 24-hour hotline
- ▶ Comprehensive training program
- ▶ Modular service system: Spare parts, individual repair, maintenance, maintenance contract

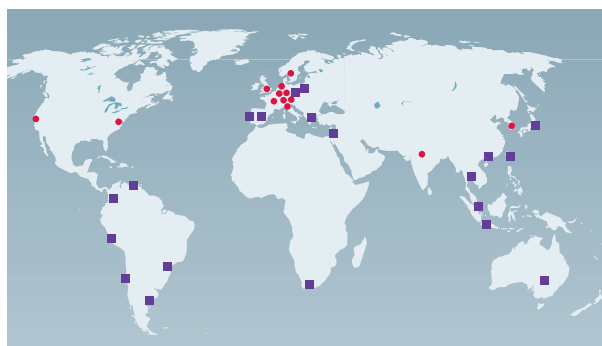

● Sales companies ■ Agencies



Pfeiffer Vacuum · Headquarters/Germany

Phone +49-(0) 64 41-8 02-0 · Fax +49-(0) 64 41-8 02-2 02 · info@pfeiffer-vacuum.de · www.pfeiffer-vacuum.net