

**Agilent 7250  
Accurate-Mass/Q-TOF  
GC/MS System**

**Troubleshooting and  
Maintenance Manual**



**Agilent Technologies**

# Notices

© Agilent Technologies, Inc. 2017

No part of this manual may be reproduced in any form or by any means (including electronic storage and retrieval or translation into a foreign language) without prior agreement and written consent from Agilent Technologies, Inc. as governed by United States and international copyright laws.

## Manual Part Number

G7250-90001

## Edition

First Edition, July 2017

Printed in USA

Agilent Technologies, Inc.  
5301 Stevens Creek Boulevard  
Santa Clara, CA 95051

## Warranty

**The material contained in this document is provided “as is,” and is subject to being changed, without notice, in future editions. Further, to the maximum extent permitted by applicable law, Agilent disclaims all warranties, either express or implied, with regard to this manual and any information contained herein, including but not limited to the implied warranties of merchantability and fitness for a particular purpose. Agilent shall not be liable for errors or for incidental or consequential damages in connection with the furnishing, use, or performance of this document or of any information contained herein. Should Agilent and the user have a separate written agreement with warranty terms covering the material in this document that conflict with these terms, the warranty terms in the separate agreement shall control.**

## Safety Notices

### CAUTION

A **CAUTION** notice denotes a hazard. It calls attention to an operating procedure, practice, or the like that, if not correctly performed or adhered to, could result in damage to the product or loss of important data. Do not proceed beyond a **CAUTION** notice until the indicated conditions are fully understood and met.

### WARNING

A **WARNING** notice denotes a hazard. It calls attention to an operating procedure, practice, or the like that, if not correctly performed or adhered to, could result in personal injury or death. Do not proceed beyond a **WARNING** notice until the indicated conditions are fully understood and met.

# Contents

## 1 Introduction

Abbreviations Used	8
The 7250 Accurate-Mass Quadrupole Time-of-Flight GC/MS System	10
7250 Accurate-Mass Q-TOF GC/MS Description	12
Side Panel AC Power Connectors	13
Back Panel Connectors	14
Interfacing Start Events to External Devices	15
Remote control processor	15
Remote start signals	15
System ready	15
Start run input	16
Important Safety Warnings	17
Safety and Regulatory Certifications	20
Intended Use	24
Cleaning/Recycling the Product	24
Accidental Liquid Spillage	24
Moving or Storing the MS	24

## 2 General Troubleshooting

Troubleshooting Tips and Tricks	26
General Symptoms	27
Chromatographic Symptoms	29
Mass Spectra General Symptoms	34
Pressure Symptoms	36

Temperature Symptoms	38
Common Types of Errors	40
Air Leaks	45
Contamination	46

### 3 General Maintenance

Before Starting	50
Scheduled maintenance	50
Tools, spare parts, and supplies	50
High voltage precautions	51
Dangerous temperatures	51
Chemical residue	52
Electrostatic discharge	53
To Refill the EI Calibration Vial	54
To Connect the GC Nitrogen Gas Source to the Collision Cell	56
To Separate the GC from the MS	57
To Position the GC Next to the MS	60
To Move or Store the MS	61
To Access the Left Side Lifting Handle	64

### 4 Vacuum System

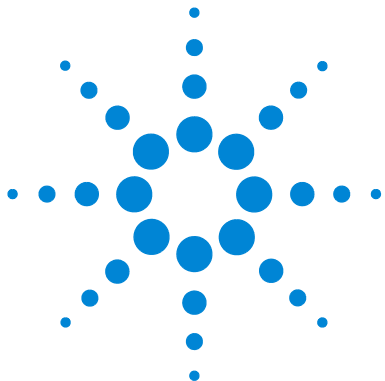
Overview	68
Maintaining the Vacuum System	69
Periodic maintenance	69
Other procedures	69
More information is available	69
Vacuum System Components	70
Common Vacuum System Problems	71
Foreline Pump	72

To replace the hepa filter cartridge	80
Side Plate	83
Vacuum Seals	83
El Calibration Valve	84

## **5 Replacement Parts**

To Order Parts	86
Electronics	87
Vacuum System	90
Analyzer	94
GC/MS Transferline interface for the 7890 GC	98
Consumables and Maintenance Supplies	100





# 1 Introduction

Abbreviations Used	8
The 7250 Accurate-Mass Quadrupole Time-of-Flight GC/MS System	10
7250 Accurate-Mass Q-TOF GC/MS Description	12
Side Panel AC Power Connectors	13
Back Panel Connectors	14
Interfacing Start Events to External Devices	15
Important Safety Warnings	17
Safety and Regulatory Certifications	20
Intended Use	24
Cleaning/Recycling the Product	24
Moving or Storing the MS	24

This chapter provides general information about the Agilent 7250 Accurate-Mass Quadrupole Time-of-Flight (Q-TOF) GC/MS System, including a hardware description and general safety warnings.



## Abbreviations Used

The abbreviations in [Table 1](#) are used in discussing this product. They are collected here for convenience.

**Table 1** Abbreviations

<b>Abbreviation</b>	<b>Definition</b>
AC	Alternating current
ALS	Automatic liquid sampler
CC	Collision cell
DC	Direct current
DIP	Direct insertion probe
EI	Electron impact
EPC	Electronic pneumatic control
eV	Electron volt
GC	Gas chromatograph
GC/MS	Gas chromatograph mass spectrometer
id	Inside diameter
IDP	Isolated dry pump
LAN	Local Area Network
LE-EI	Low energy EI
$m/z$	Mass to charge ratio
MFC	Mass flow controller
MS	Mass spectrometer
MS1	Quadrupole
OFN	Octafluoronaphthalene (sample)
PFTBA	Perfluorotributylamine (calibrant)
Q-TOF	Quadrupole time-of-flight



**Table 1** Abbreviations (continued)

<b>Abbreviation</b>	<b>Definition</b>
Quad	Quadrupole mass filter
RF	Radio frequency
RFPA	Radio frequency power amplifier
TOF	Time-of-flight
Torr	Unit of pressure, 1 mm Hg
Turbo	Turbomolecular vacuum pump

## The 7250 Accurate-Mass Quadrupole Time-of-Flight GC/MS System

The 7250 Accurate-Mass Quadrupole Time-of-Flight (Q-TOF) GC/MS System is a standalone capillary GC detector for use with the Agilent 7890 Series gas chromatograph. The 7250 Q-TOF features:

- Three turbomolecular vacuum pumps
- Foreline pump
  - Rotary vane pump
  - Dry scroll pump
- Independently MS-heated LE-EI ion source
- Independently MS-heated hyperbolic quadrupole mass filter, which can be heated to high temperatures, minimizing the contamination typical with low temperature analyses
- Single hexapole collision cell
- Ion-focusing slicer
- Vacuum-insulated flight tube with dual-stage ion mirror
- Fast electronics, allowing fast sampling rates
- Analog to digital detector
- Independently GC-heated GC/MS interface

### Physical description

The 7250 Q-TOF GC/MS is approximately 53.5 cm high, 69 cm wide, and 92 cm deep. The flight tube extends 136 cm up over the top of the instrument.

The turbo pump mainframe weighs 159 kg. The weight of the attached foreline (rotary) pump is 25 kg for the DS202 model, and 45 kg for the IDP model.

The basic components of the instrument are the:

- Frame/cover assemblies
- Vacuum system
- GC/MS interface
- Ion source

- Flight tube electronics
- Collision cell
- Detector
- Analyzer

## **Vacuum gauge**

The 7250 Q-TOF GC/MS is equipped with three ion vacuum gauges:

- Vacuum manifold chamber
- TOF vacuum manifold chamber
- Turbomolecular vacuum pumps exhaust

The MassHunter Workstation can be used to read the pressure (high vacuum) in the vacuum manifold, at the turbomolecular vacuum pump discharge, and the flight tube.

## **Ionization modes**

The 7250 Accurate-Mass Q-TOF GC/MS can operate the LE-EI ion source in standard or low energy modes.

## 7250 Accurate-Mass Q-TOF GC/MS Description

Figure 1 is an overview of a typical 7250 Accurate-Mass Q-TOF GC/MS system.

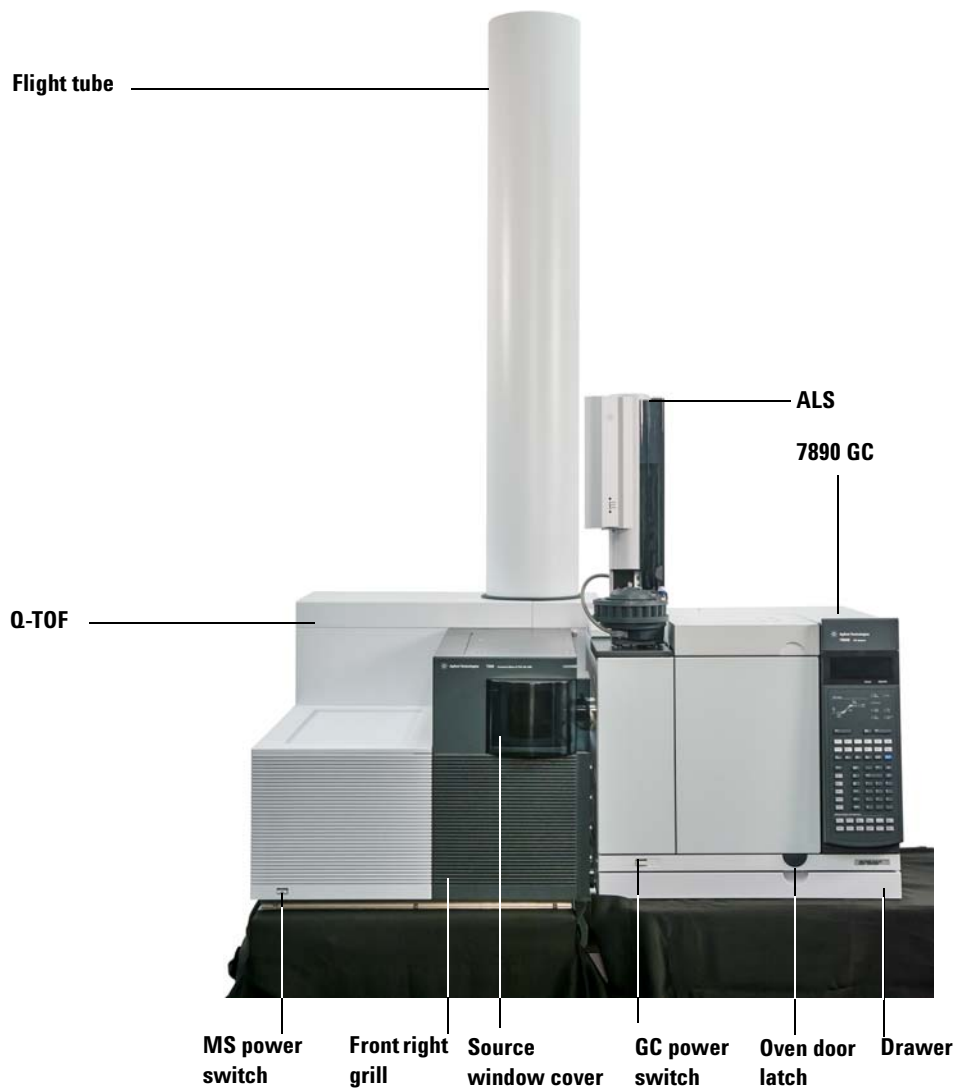


Figure 1 7250 Accurate-Mass Q-TOF GC/MS System

## Side Panel AC Power Connectors



**Figure 2** Side panel power supply

### Main power cord receptacle (top)

The AC power cord located on the left side of the MS brings in all electrical power for the MS. The power cord can be detached from the MS.

### Foreline pump power receptacle (bottom)

The foreline pump power cord receptacle located on the left side of the MS provides AC power for the foreline pump. If the power switch is off, no power is supplied to the foreline pump.

## Back Panel Connectors



**Figure 3** Back panel connections

### Remote start connector

The remote start connector is the external connector for the remote start circuitry on the LAN/MS control card. It receives remote start signals from the GC.

### LAN (I/O) connector

The LAN cable from the data system is a dedicated LAN line that is connected to the LAN communications connector. It carries all data communication between the PC and the MS.

#### **CAUTION**

Directly connect a single dedicated LAN cable between the PC and the 7250 Q-TOF. Do not use a LAN switch, router, or other device between the PC and the Q-TOF.

## Interfacing Start Events to External Devices

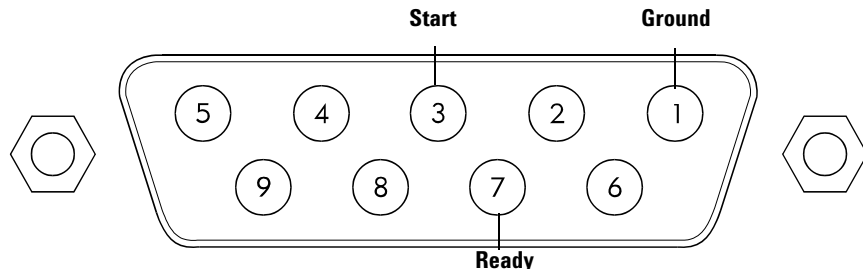
### Remote control processor

The remote control processor on the LAN/MS control card synchronizes start-run signals with GCs and other devices. The functions of the remote control processor are extended to the remote start (Remote) connector on the back panel of the MS. (See [Figure 4](#).) The remote start cable connects the GC and the MS. An optional cable can extend these events to another instrument.

### Remote start signals

It is often necessary to communicate with external devices (for example, a purge-and-trap) during a run. Typically, these communications are requests to send a system-ready signal. They also include:

- Receive a start run signal from an external device
- Program the timing of events during a run



**Figure 4** Remote start connector

### System ready

When interfacing to an external device, it is often desirable to send a system-ready signal to the device. In the case of a multisample Tekmar purge-and-trap, each sample is purged onto a trap where it waits for a ready signal. On receipt of the ready signal, the desorption cycle begins. When a specific temperature is reached, the purge-and-trap closes a contact to indicate the run has started.

The ready pin on the remote start connector on the GC is held low at all times except when the GC, MS, and data system are all ready. On system ready, a logic high of 5 VDC is present between that pin and any ground. This same high can be detected between the ready and ground pins on the remote start connector on the MS.

### **Start run input**

The best way to generate a start run signal is to use the remote start connector on the GC. Since remote start cables are made for most common devices, this is often the simplest way. A general-purpose remote start cable that terminates in spade lugs (Y-Remote Start/Stop, APG p/n G1530-61200), is also available. Ensure that the system is actually ready before the start run signal is sent.

If necessary, the remote start connector on the back of the MS can be used to send the start run signal. A contact closure between the start and ground pins will start the run if the system is ready.



## Important Safety Warnings

There are several important safety notices to always keep in mind when using the MS.

### Many internal parts of the MS carry dangerous voltages

If the MS is connected to a power source, even if the power switch is off, potentially dangerous voltages exist on:

- The wiring between the MS power cord and the AC power supply
- The AC power supply itself
- The wiring from the AC power supply to the power switch

With the power switch on, potentially dangerous voltages also exist on:

- All electronics boards in the instrument
- The internal wires and cables connected to these boards
- The wires for any heater (oven, detector, inlet, or valve box)

#### **WARNING**

**All these parts are shielded by covers. With the covers in place, it should be difficult to accidentally make contact with dangerous voltages. Unless specifically instructed to, never remove a cover unless the detector, inlet, and oven are turned off.**

---

#### **WARNING**

**If the power cord insulation is frayed or worn, the cord must be replaced. Contact your Agilent service representative.**

---

### Electrostatic discharge is a threat to MS electronics

The printed circuit boards in the MS can be damaged by electrostatic discharge. Do not touch any of the boards unless it is absolutely necessary. If you must handle them, wear a grounded wrist strap, and take other antistatic precautions.

## Precautions to take to prevent an explosion

### WARNING

The use of hydrogen gas is specifically prohibited with this product.

---

### WARNING

You **MUST** make sure the top thumbscrew on the analyzer side plate is fastened finger-tight. Do not overtighten the thumbscrews; this can cause air leaks.

You **MUST** leave the collision cell chamber top plate shipping brackets fastened. Do not remove the shipping brackets from the top plate for normal operation; they secure the top plate in the event of an explosion.

---

### WARNING

Failure to secure your MS as described above greatly increases the chance of personal injury in the event of an explosion.

---

## Many parts are dangerously hot

Many parts of the GC/MS operate at temperatures high enough to cause serious burns. These parts include, but are not limited to the:

- Inlet
- Oven and its contents
- Valve box
- Column nuts attaching the column to an inlet or detector
- Foreline pump
- GC/MS transfer line

Always cool these areas of the system to room temperature before working on them. They will cool faster if you first set the temperature of the heated zone to room temperature. Turn the zone off after it has reached the setpoint. If you must perform maintenance on hot parts, use a wrench and wear gloves. Whenever possible, cool the part of the instrument that you will be maintaining before you begin working on it.

**WARNING**

Be careful when working behind the instrument. During cool-down cycles, the GC emits hot exhaust that can cause burns.

---

**WARNING**

The insulation around the inlets, detectors, valve box, and the insulation cups is made of refractory ceramic fibers. To avoid inhaling fiber particles, we recommend the following safety procedures: ventilate your work area; wear long sleeves, gloves, safety glasses, and a disposable dust/mist respirator; dispose of insulation in a sealed plastic bag in accordance with local regulations; wash your hands with mild soap and cold water after handling the insulation.

---

### **The oil pan under the standard foreline pump can be a fire hazard**

Oily rags, paper towels, and similar absorbents in the oil pan could ignite and damage the pump and other parts of the MS.

**WARNING**

Combustible materials (or flammable/nonflammable wicking material) placed under, over, or around the foreline (roughing) pump constitutes a fire hazard. Keep the pan clean, but do not leave absorbent material such as paper towels in it.


---

## Safety and Regulatory Certifications

The 7250 Q-TOF GC/MS conforms to the following safety standards:

- Canadian Standards Association (CSA): CAN/CSA-C22.2 No. 61010-1-04
- CSA/Nationally Recognized Test Laboratory (NRTL): UL 61010-1
- International Electrotechnical Commission (IEC): 61010-1
- EuroNorm (EN): 61010-1

The 7250 Q-TOF GC/MS conforms to the following regulations on Electromagnetic Compatibility (EMC) and Radio Frequency Interference (RFI):

- CISPR 11/EN 55011: Group 1, Class A
- IEC/EN 61326-1
- AUS/NZ 

This ISM device complies with Canadian ICES-001. Cet appareil ISM est conforme a la norme NMB-001 du Canada.



The 7250 Q-TOF GC/MS is designed and manufactured under a quality system registered to ISO 9001.

The 7250 A-TOF GC/MS is RoHS compliant.

### South Korean Class A EMC Declaration

A 급 기기 ( 업무용 방송통신기자재 )

This equipment is Class A suitable for professional use and is for use in electromagnetic environments outside of the home.

이 기기는 업무용 ( A 급 ) 전자파적합기기로서 판 매자 또는 사용자는 이 점을 주 의하시 기 바라 며 , 가정외의 지역에서 사용하는 것을 목적으 로 합니다 .

## Information

The Agilent Technologies 7250 Accurate-Mass Q-TOF GC/MS meets the following International Electrotechnical Commission (IEC) classifications: Equipment Class I, Laboratory Equipment, Installation Category II, and Pollution Degree 2.

This unit has been designed and tested in accordance with recognized safety standards, and is designed for use indoors. If the instrument is used in a manner not specified by the manufacturer, the protection provided by the instrument may be impaired. Whenever the safety protection of the MS has been compromised, disconnect the unit from all power sources, and secure the unit against unintended operation.

Refer servicing to qualified service personnel. Substituting parts or performing any unauthorized modification to the instrument may result in a safety hazard.

## Symbols

Warnings in the manual or on the instrument must be observed during all phases of operation, service, and repair of this instrument. Failure to comply with these precautions violates safety standards of design and the intended use of the instrument. Agilent Technologies assumes no liability for the customer's failure to comply with these requirements.

See accompanying instructions for more information.



Indicates a hot surface.



Indicates hazardous voltages.



Indicates earth (ground) terminal.



Indicates potential explosion hazard.



Indicates radioactivity hazard.



Indicates electrostatic discharge hazard.



Indicates that you must not discard this electrical/electronic product in domestic household waste.



## Electromagnetic compatibility

This device complies with the requirements of CISPR 11. Operation is subject to the following two conditions:

- This device may not cause harmful interference.
- This device must accept any interference received, including interference that may cause undesired operation.

If this equipment does cause harmful interference to radio or television reception, which can be determined by turning the equipment off and on, the user is encouraged to try one or more of the following measures:

- Relocate the radio or antenna.
- Move the device away from the radio or television.
- Plug the device into a different electrical outlet, so that the device and the radio or television are on separate electrical circuits.
- Ensure that all peripheral devices are also certified.
- Ensure that appropriate cables are used to connect the device to peripheral equipment.
- Consult your equipment dealer, Agilent Technologies, or an experienced technician for assistance.

Changes or modifications not expressly approved by Agilent Technologies could void the user's authority to operate the equipment.

## Sound emission declaration

### Sound pressure

Sound pressure  $L_p < 70$  dB according to EN 27779:1991 and EN ISO 3744:1995.

### Schalldruckpegel

Schalldruckpegel  $L_P < 70$  dB nach EN 27779:1991 und EN ISO 3744:1995.

## Intended Use

Agilent products must only be used in the manner described in the Agilent product user guides. Any other use may result in damage to the product or personal injury. Agilent is not responsible for any damages caused, in whole or in part, by improper use of the products, unauthorized alterations, adjustments or modifications to the products, failure to comply with procedures in Agilent product user guides, or use of the products in violation of applicable laws, rules or regulations.

## Cleaning/Recycling the Product

To clean the unit, disconnect the power and wipe down with a damp, lint-free cloth. For recycling, contact your local Agilent sales office.

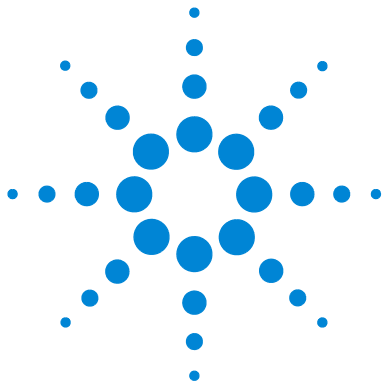
## Accidental Liquid Spillage

Do not spill liquids on the MS. If liquid is accidentally spilled on the MS, first, cut the power. Once the MS is disconnected from all power sources, dry all affected parts. If the liquid spillage affects the electronics, wait at least 24 hours, depending upon the ambient humidity. While waiting for the parts to dry, please call your local Agilent service representative.

## Moving or Storing the MS

The best way to keep your MS functioning properly is to keep it pumped down and hot, with carrier gas flow. If you plan to move or store your MS, a few additional precautions are required. The MS must remain upright at all times; this requires special caution when moving. The MS should not be left vented to atmosphere for long periods. For more information, see [“To Move or Store the MS”](#) on page 61.





## 2 General Troubleshooting

Troubleshooting Tips and Tricks	26
General Symptoms	27
Chromatographic Symptoms	29
Mass Spectra General Symptoms	34
Pressure Symptoms	36
Temperature Symptoms	38
Common Types of Errors	40
Air Leaks	45
Contamination	46

This is a quick reference to symptoms and possible causes of the most common problems experienced by users. For each symptom, one or more possible causes are listed. In general, the causes listed first are the most likely causes *or* the easiest to check and correct.

This chapter does not include corrective actions for the possible causes listed. Some of the corrective actions required may be dangerous if performed incorrectly. Do not attempt any corrective actions unless you are sure you know the correct procedure and the dangers involved. See the other chapters in this manual for more information.

If the material in this chapter and in the online help proves insufficient to help you diagnose a problem, contact your Agilent Technologies service representative.



### Troubleshooting Tips and Tricks

#### **Rule 1: “Look for what has been changed.”**

Many problems are introduced accidentally by human actions. Every time any system is disturbed, there is a chance of introducing a new problem.

- If the MS was just pumped down after maintenance, suspect air leaks or incorrect assembly.
- If carrier gas or helium gas purifier was just changed, suspect leaks or contaminated or incorrect gas.
- If the GC column was just replaced, suspect air leaks or a contaminated or bleeding column.

#### **Rule 2: “If complex isn’t working, go back to simple.”**

A complex task is not only more difficult to perform, but also more difficult to troubleshoot. If you’re having trouble detecting your sample, verify that autotune is successful.

#### **Rule 3: “Divide and conquer.”**

This technique is known as “half-split” troubleshooting. If you can isolate the problem to only part of the system, it is much easier to locate.

To determine whether an air leak is in the GC or the MS, vent the MS, remove the column, and install the blank interface ferrule. If the leak goes away, it was in the GC.

## General Symptoms

This section describes symptoms you might observe when first turning on the GC/MS system. All of these symptoms would prevent operation of the system.

### GC does not turn on

Nothing happens when the GC is switched on. The GC fans do not turn on and the keypad display does not light.

- Disconnected GC power cord
- No voltage or incorrect voltage at the electrical outlet
- Failed fuse in the GC
- GC power supply is not working correctly

### MS does not turn on

Nothing happens when the MS is switched on. The foreline pump does not start. The cooling fan for the high-vacuum pump does not turn on.

- Disconnected MS power cord
- No voltage or incorrect voltage at the electrical outlet
- Failed primary fuses - Not user replaceable
- MS electronics are not working correctly

### Foreline pump is not operating

The MS is receiving power (the fan is operating) but the foreline pump is not operating.

- A large air leak (usually the analyzer door open) has caused pumpdown failure. You must power cycle the MS to recover from this state.
- Disconnected foreline pump power cord
- Malfunctioning foreline pump
- Check power switch on foreline pump

### **MS turns on but then the foreline pump shuts off**

The MS will shut down both the foreline pump and the turbo pumps if the system fails to pump down correctly. This is usually because of a large air leak or the side plate has not sealed correctly. This feature helps prevent the foreline pump from sucking air through the system, which can damage the analyzer and the turbo pumps.

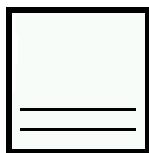
You must power cycle the MS to recover from this state.

## Chromatographic Symptoms

These are symptoms you may observe in the chromatograms generated by data acquisition. In general, these symptoms do not prevent you from operating your GC/MS system. They indicate, however, that the data you are acquiring may not be the best data obtainable. These symptoms can be caused by instrument malfunctions, but are more likely caused by incorrect chromatographic technique.

Two of the symptoms, *Low sensitivity* and *Poor repeatability* also apply to mass spectral data.

### No peaks



If an analysis shows no chromatographic peaks, only a flat baseline or minor noise, run the automated tune program. If the MS passes tune, the problem is most likely related to the GC. If the MS does not pass tune, the problem is most likely in the MS.

#### Passes tune

- Incorrect sample concentration
- No analytes present
- Syringe missing from the ALS or not installed correctly
- Injection accidentally made in split mode instead of splitless mode
- Empty or almost empty sample vial
- Dirty GC inlet
- Leaking GC inlet\*
- Loose column nut at the GC inlet\*

\* This could cause a fault condition in the GC that would prevent the GC from operating.

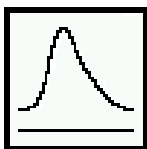
#### Does not pass tune

- Calibration vial is empty
- Excessive foreline or analyzer chamber pressure
- Very dirty ion source

## 2 General Troubleshooting

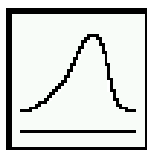
- Calibration valve is not working correctly
- Bad signal cable connection
- Filament has failed or is not connected correctly
- Bad ion source wiring connection
- Bad detector wiring connection
- Failed MS detector

### Peaks are tailing



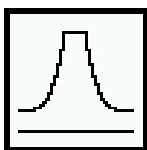
- Active sites in the sample path
- Injection is too large
- Incorrect GC inlet temperature
- Insufficient column flow
- GC/MS interface temperature is too low
- Ion source temperature is too low

### Peaks are fronting



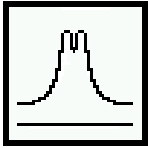
- Column film thickness mismatched with analyte concentration (column overload)
- Initial oven temperature is too low
- Active sites in the sample path
- Injection is too large
- GC inlet pressure too high
- Insufficient column flow

### Peaks have flat tops



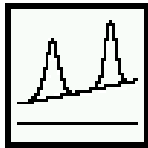
- Insufficient solvent delay
- Incorrect scale on the display
- Injection is too large

### Peaks have split tops



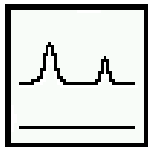
- Bad injection technique
- Injection is too large

### Baseline is rising



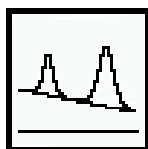
- Column bleed
- Other contamination

### Baseline is high



- Column bleed
- Other contamination

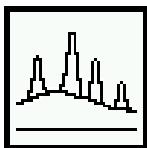
### Baseline is falling



A falling baseline indicates contamination is being swept away. Wait until the baseline reaches an acceptable level. Common causes include:

- Residual air and water from a recent venting
- Column bleed
- Septum bleed
- Splitless injection time too long (inlet is not properly swept, resulting in excess solvent on the column and slow solvent decay)

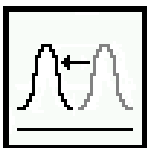
### Baseline wanders



- Insufficient carrier gas supply pressure\*
- Malfunctioning flow or pressure regulator\*
- Intermittent leak in the GC inlet\*

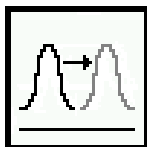
\* This could cause a fault condition in the GC that would prevent the GC from operating.

### Retention times for all peaks drift – shorter



- Column has been shortened
- Initial oven temperature was increased
- Column is getting old

### Retention times for all peaks drift – longer



- Column flow has been reduced
- Initial oven temperature was decreased
- Active sites in the sample path
- Leaks in the GC inlet\*

\* This could cause a fault condition in the GC that would prevent the GC from operating.

### Poor sensitivity

- Incorrect tuning, or tune file that does not match the type of analysis
- Repeller voltage is too low
- Incorrect temperatures (oven, GC/MS interface, ion source, or mass filter)
- Incorrect sample concentration
- Leaking GC inlet\*
- Dirty GC inlet
- Incorrect split ratio
- Purge-off time in splitless mode is too short



- Excessive pressure in the analyzer chamber
- Dirty ion source
- Air leaks between chambers
- Poor filament operation
- Detector is not working correctly
- Incorrect mass filter polarity
- Collision cell voltage

\* This could cause a fault condition in the GC that would prevent the GC from operating.

### **Poor repeatability**

- Dirty syringe needle
- Dirty GC inlet
- Leaking GC inlet\*
- Injection is too large
- Loose column connections
- Variations in pressure, column flow, and temperature
- Dirty ion source
- Loose connections in the analyzer
- Ground loops

\* This could cause a fault condition in the GC that would prevent the GC from operating.

### Mass Spectra General Symptoms

This section describes symptoms you might observe in mass spectra. Some of these symptoms will appear in the mass spectra of samples. Others you will observe only in a tune report. Some of these symptoms have causes that can be corrected by the operator. Others, however, require service by an Agilent Technologies service representative.

Two of the chromatographic symptoms, *Poor sensitivity* and *Poor repeatability* also apply to mass spectra.

#### No peaks

- Ion source cables not connected
- Bad connections to or from the detector
- Detector power supply output cable has failed
- Collision cell voltages
- Collision cell gas flow
- Other electronics failure
- Incorrect tune file (inappropriate parameters)

#### Isotopes are missing or isotope ratios are incorrect

- Wrong precursor or wrong product ion was selected
- MCP or PMT voltage is too low
- Repeller voltage is too high
- Wrong ions are chosen
- High background
- Dirty ion source
- Collision cell voltage
- Collision cell gas flow

## High background

- TOF vacuum or Quad vacuum
- Air leak
- Contamination

## Pressure Symptoms

This section describes unusual pressure readings and their possible causes. At typical column flow rates (0.5 to 2.0 mL/minute), the foreline pressure will be approximately 16 to 18 mTorr. The Quad pressure with collision cell gas on or off will be approximately  $1 \times 10^{-4}$  to  $2 \times 10^{-4}$  Torr. These pressures can vary widely from instrument to instrument so it is very important that you are familiar with the pressures that are typical for your instrument at given carrier and collision gas flows.

**Table 2** Influence of carrier and collision cell gas flows on vacuum

Column flow (mL/min)	Rough Vac (mTorr)	CC Gas On N2 = 1 mL/min He = 4 mL/min		CC Gas Off		
		Quad Vac (Torr)	TOF Vac (Torr)	Rough Vac (mTorr)	Quad Vac (Torr)	TOF Vac (Torr)
0.7	1.25 E+02	3.50 E-05	2.61 E-07	2.70 E+01	5.78 E-07	1.58 E-07
1	1.30 E+02	3.49 E-05	2.61 E-07	3.61 E+01	6.21 E-07	1.58 E-07
1.2	1.34 E+02	3.49 E-05	2.61 E-07	4.13 E+01	6.55 E-07	1.58 E-07
2	1.48 E+02	3.51 E-05	2.61 E-07	6.18 E+01	8.09 E-07	1.59 E-07
3	1.63 E+02	3.52 E-05	2.61 E-07	8.45 E+01	9.99 E-07	1.60 E-07

### Foreline pressure is too high

If the pressure you observe for a given column flow has increased over time, check the following:

- Column (carrier gas) flow is too high
- Collision cell gas flow is too high
- Air leak (usually the side plate is not pushed in or vent valve is open)
- Rotary foreline pump oil level is low or oil is contaminated
- IDP tip seal is worn down and needs replacing
- Foreline hose is constricted
- Foreline pump is not working correctly

## Foreline pressure is too low

If the pressures you observe are below 20 mTorr, check for the following:

- Column (carrier gas) flow is too low
- Column plugged or crushed by an overtightened nut
- Collision gas flows are too low
- Empty or insufficient carrier gas supply\*
- Bent or pinched carrier gas tubing\*
- Foreline gauge is not working correctly

\* This could create a fault condition in the GC that would prevent the GC from operating.

## Quad pressure is too low

If the pressure you observe is below  $1 \times 10^{-6}$  Torr with the collision cell gas on or off, check for the following:

- Column (carrier gas) flow is too low
- Collision gas flows are too low
- Column plugged or crushed by overtightened nut
- Empty or insufficient carrier gas supply\*
- Bent or pinched carrier gas tubing\*

\* This could create a fault condition in the GC that would prevent the GC from operating.

## High vacuum pressure is too low

If the pressure you observe is above  $2 \times 10^{-6}$  Torr, check for the following:

- Turbos are not up to speed
- Too much water is in the system
- Did not wait long enough for system to pump down
- Poor carrier gas quality
- System is not leak tight, check fittings

### Temperature Symptoms

The MS has three heated zones:

- Ion source
- Mass filter
- GC/MS interface

Each heated zone has a heater and temperature sensor. The ion source and mass filter are powered and controlled by the MS. The GC/MS interface is powered and controlled by the GC.

#### Ion source will not heat up

- High-vacuum pump is off or has not reached normal operating conditions\*
- Incorrect temperature setpoint
- Ion source has not had enough time to reach temperature setpoint
- Ion source heater cartridge is not connected\*
- Ion source temperature sensor is not connected\*
- Ion source heater failed (burned out or shorted to ground)\*
- Ion source temperature sensor failed\*
- Source power cable is not connected to the quadrupole board\*
- MS electronics are not working correctly

\* This will cause an error message.

#### Mass filter (quad) heater will not heat up

- High-vacuum pump is off or has not reached normal operating conditions\*
- Incorrect temperature setpoint
- Mass filter has not had enough time to reach temperature setpoint
- Mass filter heater cartridge is not connected\*
- Mass filter temperature sensor is not connected\*
- Mass filter heater failed (burned out or shorted to ground)\*
- Mass filter temperature sensor failed\*
- Cable is not connected to the quadrupole board\*

- MS electronics are not working correctly
  - \* This will cause an error message.

### **GC/MS interface will not heat up**

- Incorrect setpoint(s)
- Setpoint entered in wrong heated zone
- GC/MS interface has not had enough time to reach temperature setpoint
- GC is off
- GC experienced a fault and needs to be reset\*
- GC/MS interface heater/sensor cable is not connected\*
- GC/MS heater failed (burned out)\*
- GC/MS sensor failed\*
- GC electronics are not working correctly\*
  - \* This will cause a GC error message. GC error messages are described in the documentation supplied with your GC.

### Common Types of Errors

Sometimes a problem in your MS will cause an error message to appear in the MassHunter Workstation software. Some error messages appear only during tuning. Other messages may appear during tuning or data acquisition.

Some error messages are “latched.” These messages remain active in your data system even if the condition that caused the message has corrected itself. If the cause is removed, these messages can be removed by checking instrument status through the data system.

#### Difficulty in mass filter electronics

- Pressure in the analyzer chamber is too high
- RFPA is not adjusted correctly
- Mass filter (quad) contacts are shorted or otherwise not working correctly
- Mass filter is not working correctly
- MS electronics are not working correctly

#### Difficulty with the photo multiplier or microchannel device

- Broad peaks, such as the solvent peak, eluted while the analyzer was on
- MS electronics are not working correctly

#### Difficulty with the fan

If a cooling fan fault occurs, the vacuum control electronics automatically shut off the high-vacuum pump, the ion source, and mass filter heaters. Therefore, the message: “The system is in vent state” may also appear. It is important to note that even though the high-vacuum pump is off, the analyzer chamber may not actually be vented. See [“The system is in vent state”](#) on page 43 in this section for precautions to take.

- The fan is disconnected
- The fan has failed
- MS electronics are not working correctly



## Difficulty with the high vacuum pump(s)

If the pump failed to reach 50% of full speed within 10 minutes, or experienced a fault.

You must switch the MS off and back on to remove this error message. Ensure the turbo pump has slowed down before switching off the MS. The message will reappear if the underlying problem has not been corrected.

- Large vacuum leak is preventing the turbo pump from reaching 50% of full speed
- Foreline pump is not working correctly
- Turbo pump(s) is not working correctly
- MS electronics are not working correctly

## High foreline pressure

- Excessive carrier gas flow (typically > 5 mL/min)
- Excessive solvent volume injected
- Large vacuum leak
- Severely degraded foreline pump oil
- Collapsed or kinked foreline hose
- Foreline pump is not working correctly

## Internal MS communication fault

- MS electronics are not working correctly

## Lens supply fault

- Electrical short in the analyzer
- MS cannot maintain the voltage setpoint
- MS electronics are not working correctly

### No peaks found

- Emission current was set to 0
- PMT or MCP voltage is too low
- Calibration vial(s) empty or almost empty
- Excessive pressure in the analyzer chamber
- Air leak
- Signal cable is not connected
- Electrical leads to the MCP are not connected correctly
- Electrical leads to the ion source are not connected correctly
- Filament to the source body is shorted

### Temperature control disabled

- One of the heater fuses has failed
- MS electronics are not working correctly

### Temperature control fault

This indicates that something has gone wrong with the temperature control of either the ion source or the mass filter (quad) heater:

- Source temperature sensor is open
- Source temperature sensor is shorted
- Mass filter (quad) temperature sensor is open
- Mass filter (quad) temperature sensor is shorted
- No heater voltage (heater fuse has probably failed)
- Heater voltage is too low
- Temperature zone has timed out (heater failed, bad heater wiring, or loose temperature sensor)
- Problem with the temperature control electronics
- Source heater is open
- Source heater is shorted
- Mass filter heater is open
- Mass filter heater is shorted

### The high-vacuum pump is not ready

- One of the three Turbo pumps could have failed
- Turbo pump is on but has not had enough time (10 minutes) to reach 80% of its normal operating speed
- Turbo pump is not working correctly
- Foreline pump has not reached its target of 10 Torr after 10 minutes
- MS electronics are not working correctly

### The system is in vent state

The message says the system is vented, but if the fault has just occurred it may still be under vacuum and the turbo pump may still be at high speed. Wait at least 30 minutes after seeing this message before you actually vent the MS.

#### CAUTION

Venting the MS too soon after this message appears can damage a turbo pump.

- 
- System was vented purposely (no problem)
  - Fan fault has turned off the high-vacuum pump (power cycle the MS to clear the fault)
  - Fuse for the high-vacuum pump has failed
  - MS electronics are not working correctly

### There is no emission current

- Check tune file to be certain that emission current is not = 0
- Filament is not connected properly; try the other filament
- Filament has failed; try the other filament
- MS electronics are not working correctly

### There is not enough signal to begin tune

- Corrupted tune file
- Poor mass axis calibration

## 2 General Troubleshooting

- Width gain or offset is too high
- Calibration vial empty or almost empty
- Excessive pressure in the analyzer chamber
- Air leak
- MCP or PMT voltage is too low
- Signal cable is not connected
- Electrical leads to the detector are not connected correctly
- Electrical leads to the ion source are not connected correctly
- Filament shorted to the source body
- Collision cell gas flow
- Collision cell voltages

## Air Leaks

Air leaks are a problem for any instrument that requires a vacuum to operate. Leaks are generally caused by vacuum seals that are damaged or not fastened correctly. Symptoms of leaks include:

- Higher than normal analyzer chamber pressure or foreline pressure
- Higher than normal background
- Peaks characteristic of air ( $m/z$  18, 28, 32, and 44 or  $m/z$  14 and 16)
- Poor sensitivity
- Low relative abundance of  $m/z$  502 (this varies with the tune program used)

Leaks can occur in either the GC or the MS. The most likely point for an air leak is a seal you recently opened.

In the GC, most leaks occur in:

- GC inlet septum
- GC inlet column nut
- Broken or cracked capillary column

Leaks can occur in many more places in the MS:

- GC/MS interface column nut
- Side plate O-rings (all the way around)
- Calibration valve
- GC/MS interface O-ring (where the interface attaches to the analyzer chamber)
- End plate O-ring
- Turbo pump O-rings
- Collision cell cover O-ring

### Contamination

Contamination is usually identified by excessive background in the mass spectra. It can come from the GC or from the MS. The source of the contamination can sometimes be determined by identifying the contaminants. Some contaminants are much more likely to originate in the GC. Others are more likely to originate in the MS.

Contamination originating in the GC typically comes from one of these sources:

- Column or septum bleed
- Dirty GC inlet
- GC inlet liner
- Contaminated syringe
- Poor quality carrier gas
- Dirty carrier gas tubing
- Fingerprints (improper handling of clean parts)

Contamination originating in the MS typically comes from one of the following sources:

- Air leak
- Cleaning solvents and materials
- Rotary foreline pump oil
- Fingerprints (improper handling of clean parts)

**Table 3**, “Common contaminants,” on page 47 lists some of the more common contaminants, the ions characteristic of those contaminants, and the likely sources of those contaminants.

**Table 3** Common contaminants

Ions ( $m/z$ )	Compound	Possible source
18, 28, 32, 44 or 14, 16	H <sub>2</sub> O, N <sub>2</sub> , O <sub>2</sub> , CO <sub>2</sub> or N, O	Residual air and water, air leaks, outgassing from Vespel ferrules
31, 51, 69, 100, 119, 131, 169, 181, 214, 219, 264, 376, 414, 426, 464, 502, 576, 614	PFTBA and related ions	PFTBA (tuning compound)
31	Methanol	Cleaning solvent
43, 58	Acetone	Cleaning solvent
78	Benzene	Cleaning solvent
91, 92	Toluene or xylene	Cleaning solvent
105, 106	Xylene	Cleaning solvent
151, 153	Trichloroethane	Cleaning solvent
69	Foreline pump oil or PFTBA	Foreline pump oil vapor or calibration valve leak
73, 147, 207, 221, 281, 295, 355, 429	Dimethylpolysiloxane	Septum bleed or methyl silicone column bleed
149	Plasticizer (phthalates)	Vacuum seals (O-rings) damaged by high temperatures, vinyl gloves
Peaks spaced 14 $m/z$ apart	Hydrocarbons	Fingerprints, foreline pump oil

## 2 General Troubleshooting





## 3 General Maintenance

- Before Starting 50
- To Refill the EI Calibration Vial 54
- To Connect the GC Nitrogen Gas Source to the Collision Cell 56
- To Separate the GC from the MS 57
- To Position the GC Next to the MS 60
- To Move or Store the MS 61
- To Access the Left Side Lifting Handle 64

This chapter describes maintenance procedures and requirements that are used with all Agilent 7250 Accurate Mass Q-TOF GC/MS Systems.



## Before Starting

For your safety, read all of the information in this introduction before performing any maintenance tasks.

### Scheduled maintenance

Common maintenance tasks are listed in [Table 4](#). Performing these tasks when scheduled can reduce operating problems, prolong system life, and reduce overall operating costs.

Keep a record of system performance (tune reports) and maintenance operations performed. This makes it easier to identify variations from normal operation and to take corrective action.

**Table 4** Maintenance schedule

Task	Every week	Every 6 months	Every year	As needed
Tune the MS				X
Check the standard foreline pump oil level	X			
Check the calibration vial		X		
Replace the foreline pump oil		X		
Check the standard foreline pump				X
Replace the tip seal on the optional IDP			X	
Replace the filters on the optional IDP			X	
Clean the ion source				X
Check the carrier gas trap(s) on the GC				X
Replace the worn out parts				X
Replace GC gas supplies				X

### Tools, spare parts, and supplies

Some of the required tools, spare parts, and supplies are included in the GC shipping kit, MS shipping kit, or MS tool kit. You must supply others yourself. Each maintenance procedure includes a required materials list.

## High voltage precautions

When the MS is plugged in, even if the power switch is off, dangerous voltage (200/240 VAC) exists on the wiring and fuses between where the power cord enters the instrument and the power switch.

When the power switch is on, dangerous voltages exist on:

- Electronic circuit boards
- Toroidal transformer
- Wires and cables between these boards
- Wires and cables between these boards and the connectors on the back panel of the MS
- Some connectors on the back panel (for example, the foreline power receptacle)

Normally, all of these parts are shielded by safety covers. As long as the safety covers are in place, it should be difficult to accidentally make contact with dangerous voltages.

### WARNING

**Do not perform maintenance with the MS turned on or plugged into its power source, unless you are instructed to do so by one of the procedures in this chapter.**

---

Some procedures in this chapter require access to the inside of the MS while the power switch is on. Do not remove any of the electronics safety covers in any of these procedures. To reduce the risk of electric shock, follow the procedures carefully.

## Dangerous temperatures

Many parts in the MS operate at, or reach, temperatures high enough to cause serious burns. These parts include, but are not limited to:

- GC/MS interface
- Analyzer parts
- Vacuum pumps

### WARNING

**The foreline pump can cause burns if touched when operating.**

---

**WARNING**

Never touch these parts while your MS is on. After the MS is turned off, give these parts enough time to cool before handling them.

---

**WARNING**

The GC/MS interface heater is powered by a heated zone on the GC. The interface heater can be on, and at a dangerously high temperature, even though the MS is off. The GC/MS interface is well insulated. Even after it is turned off, it cools very slowly.

---

The GC inlets and GC oven also operate at very high temperatures. Use the same caution around these parts. See the documentation supplied with your GC for more information.

## Chemical residue

Only a small portion of your sample is ionized by the ion source. The majority of any sample passes through the ion source without being ionized. It is pumped away by the vacuum system. As a result, the exhaust from the foreline pump will contain traces of the carrier gas and your samples. Exhaust from the standard foreline pump also contains tiny droplets of foreline pump oil.

An oil mist filter is supplied with the standard foreline pump. This filter stops *only* pump oil droplets. It *does not* trap any other chemicals. If you are using toxic solvents or analyzing toxic chemicals, install a hose from the mist filter outlet to the outdoors or into a fume hood vented to the outdoors. Comply with your local air quality regulations.

**WARNING**

The oil trap supplied with the standard foreline pump stops only foreline pump oil. It does not trap or filter out toxic chemicals. If you are using toxic solvents or analyzing toxic chemicals, vent the exhaust to a safe location.

---

The fluid in the standard foreline pump also collects traces of the samples being analyzed. All used pump fluid should be considered hazardous and handled accordingly. Dispose of used fluid as specified by your local regulations.

**WARNING**

When replacing pump fluid, use appropriate chemical-resistant gloves and safety glasses. Avoid all contact with the fluid.

---

**WARNING**

Always perform any maintenance procedures using hazardous solvents under a fume hood. Operate the MS in a well-ventilated room.

---

## Electrostatic discharge

All of the printed circuit boards in the MS contain components that can be damaged by electrostatic discharge (ESD). Do not handle or touch these boards unless absolutely necessary. In addition, wires, contacts, and cables can conduct ESD to the electronics boards to which they are connected. This is especially true of the mass filter (quadrupole) contact wires, which can carry ESD to sensitive components on the quadrupole board. ESD damage may not cause immediate failure, but it will gradually degrade the performance and stability of your MS.

When you work on or near printed circuit boards, or when you work on components with wires, contacts, or cables connected to printed circuit boards, always use a grounded antistatic wrist strap and take other antistatic precautions. The wrist strap should be connected to a known good earth ground. If that is not possible, it should be connected to a conductive (metal) part of the assembly being worked on, but *not* to electronic components, exposed wires or traces, or pins on connectors.

Take extra precautions, such as a grounded antistatic mat, if you must work on components or assemblies that have been removed from the MS. This includes the analyzer.

**CAUTION**

To be effective, an antistatic wrist strap must fit snugly (not tight). A loose strap provides little or no protection.

Antistatic precautions are not 100% effective. Handle electronic circuit boards as little as possible and then only by the edges. Never touch components, exposed traces, or pins on connectors and cables.

---

## To Refill the EI Calibration Vial

### Materials needed

- Gloves, clean, lint-free
  - Large (8650-0030)
  - Small (8650-0029)
- PFTBA (05971-60571)



### Procedure

- 1 Stop any tuning or data acquisition.
- 2 Turn off the MS electronics.
- 3 Remove the source window cover. See the *Agilent 7250 Accurate-Mass Q-TOF GC/MS System Operation Manual*.
- 4 Turn the calibration vial collar counterclockwise to loosen it. (See [Figure 5](#).) Do not remove the collar.
- 5 Pull the calibration vial out. You may feel some resistance due to the O-ring around the vial tube section.



**Figure 5** Removing the EI calibration vial

- 6 Syringe or pipette PFTBA into the vial. With the vial vertical, the liquid should be just below the end of the internal tube, approximately 70-120  $\mu\text{L}$  of sample.

- 7 Push the calibration vial into the valve as far as possible.
- 8 Withdraw the vial 1 mm. This prevents damage when you tighten the collar.
- 9 Turn the collar clockwise to tighten it.

The collar should be snug but not overly tight. Do *not* use a tool to tighten the collar. It does not require that much force.

- 10 Reinstall the source window cover.
- 11 In the **Instrument Control** panel, select the **MS Tune** icon to display the **GC-Q-TOF Tune** dialog box. Select the **Manual Tune** tab then select the **Ion Source** tab to display the ion source parameters.
- 12 Turn off the **Emission** by selecting the check box.
- 13 Purge the calibration valve by selecting the **EI Cal Valve** check box to open the calibration valve. Close the **EI Cal Valve** after 30 seconds.

**CAUTION**

After removing a calibrant vial, you *must* purge the calibration valve. Failure to do so will result in damage to the filament, microchannel plate, and the photomultiplier.

---

## To Connect the GC Nitrogen Gas Source to the Collision Cell

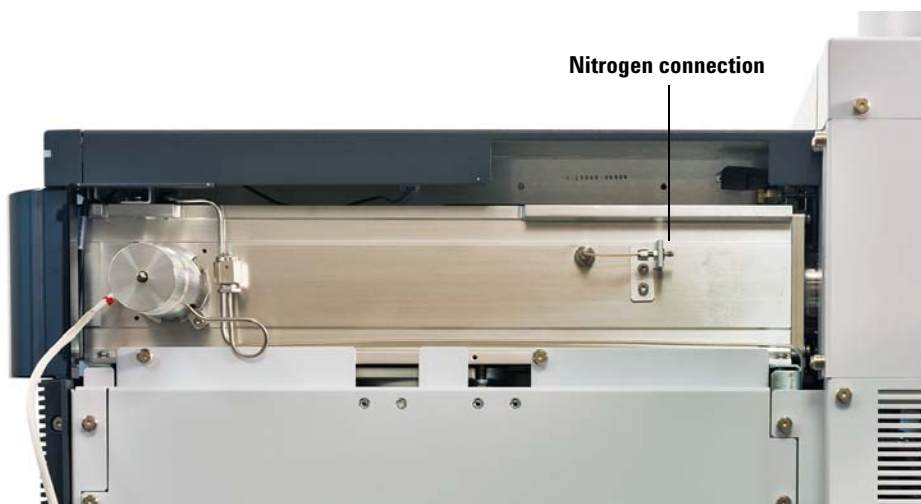
### Materials needed

- Wrench, open-end, 1/4-inch × 5/16-inch (8710-0510)
- Ferrule
- Swagelock nut



### Procedure

- 1 With the MS vented, use a 5/16 in. wrench to remove the cap from the nitrogen connection located on the side of the instrument near the transfer line.



**Figure 6** Collision cell nitrogen gas connection

- 2 Place Swagelok nut and ferrule on the end of the nitrogen line tubing from the GC.
- 3 Connect the nitrogen line to the instrument.



## To Separate the GC from the MS

This procedure is used for relocating or storing the instrument.

### Materials needed

- Ferrule, blank (5181-3308)
- Self Tightening Column Nut (Recommended, 5190-5233), or interface column nut (05988-20066)
- Wrench, open-end, 1/4-inch × 5/16-inch (8710-0510)

### WARNING

**Ensure the GC/MS interface and the analyzer zones are cool (below 100 °C) before you vent the MS. A temperature of 100 °C is hot enough to burn skin; always wear cloth gloves when handling analyzer parts.**

---

### WARNING

**The use of hydrogen gas is specifically prohibited with this product.**

---

### CAUTION

Ensure the GC oven and the GC/MS interface are cool before turning off carrier gas flow.

---

### WARNING

**Ensure the GC/MS interface, GC inlet, and GC oven have cooled before you remove the column. These areas can be hot enough to burn skin.**

---

### Procedure

- 1 Cool down the GC/MS interface, GC inlet, and GC oven.
- 2 Before separating the GC from the MS, ensure that the capillary column in the GC oven is either disconnected from the transfer line, or has enough slack uncoiled from the column hanger. Transportation of either instrument requires a disconnection of the transfer line.

### 3 General Maintenance

- 3 The foreline pump may be located on the floor, on the lab bench next to or behind the MS, or under the analyzer chamber at the back of the MS. Move it as needed to provide slack in the tubing and cables.
- 4 Carefully pull the GC away from the MS until you have access to the GC/MS interface cable. (See [Figure 7](#), “Separating/connecting the MS and GC,” on page 59.) The GC is guided as it slides by the spacer bracket underneath both instruments.
- 5 Disconnect the GC/MS interface cable. Disconnecting the cable with the GC on can cause a fault condition.

If you are moving or storing the MS, see [“To Move or Store the MS”](#) on page 61.



**Figure 7** Separating/connecting the MS and GC

## To Position the GC Next to the MS

This procedure is used to position the GC next to the MS after moving the GC away from the MS, or after relocating the instrument.

To perform this procedure, the GC/MS interface, GC oven, and GC inlet should be cool.

### Procedure

- 1 Slide the units together and ensure you do not damage the transfer line.
- 2 Before closing the gap between the MS and the GC, connect the interface cable.
- 3 Push the GC towards the MS, and close the gap.
- 4 If needed, connect the column to the transfer line. See the *Agilent 7250 Accurate-Mass Q-TOF GC/MS System Operation Manual*.
- 5 Wind the excess column slack in the GC oven around the column basket.
- 6 Turn on the GC, and start carrier gas flow.

## To Move or Store the MS

### Materials needed

- Ferrule, blank (5181-3308)
- Self Tightening Column Nut (Recommended, 5190-5233), or interface column nut (05988-20066)
- 2 Wrenches, open-end, 1/4-inch × 5/16-inch (8710-0510)

### Procedure

**WARNING**

Ensure the GC/MS interface and the analyzer zones are cool (below 100 °C) before you vent the MS. A temperature of 100 °C is hot enough to burn skin; always wear cloth gloves when handling analyzer parts.

---

**WARNING**

The use of hydrogen gas is specifically prohibited with this product.

---

**WARNING**

When the MS is vented, do not put the MassHunter Workstation software into Instrument Control view. Doing so will turn on the interface heater.

---

**CAUTION**

Ensure the GC oven and the GC/MS interface are cool before turning off the carrier gas flow.

---

**CAUTION**

Never vent the MS by allowing air in through either end of the foreline hose. Always use the automated procedure in MassHunter Data Acquisition to vent the MS.

Do not exceed the maximum recommended total gas flow.

---

- 1 Cool down the GC and MS. See the *Agilent 7250 Accurate-Mass Q-TOF GC/MS System Operation Manual*.

### 3 General Maintenance

- 2 Vent the MS. See the *Agilent 7250 Accurate-Mass Q-TOF GC/MS System Operation Manual*.
- 3 Shut off the carrier gas at the source.
- 4 Shut off the GC, and unplug the power cord.
- 5 Disconnect the GC column from the transfer line, and cap the end of the transfer line with a blank ferrule. See the *Agilent 7250 Accurate-Mass Q-TOF GC/MS System Operation Manual*.
- 6 Disconnect the MS power cords on the left side of the instrument.
- 7 Disconnect the LAN cable, control wires, and carrier gas located on the back of the instrument. See “Side Panel AC Power Connectors” on page 13.
- 8 Separate the GC from the MS. See “To Separate the GC from the MS” on page 57.
- 9 Disconnect the collision gas supply tubing, and install a plug.
- 10 Remove the source window cover (see Figure 10, “Remove covers to access the left side lifting handles,” on page 64), then remove the analyzer cover. (See Figure 8.)

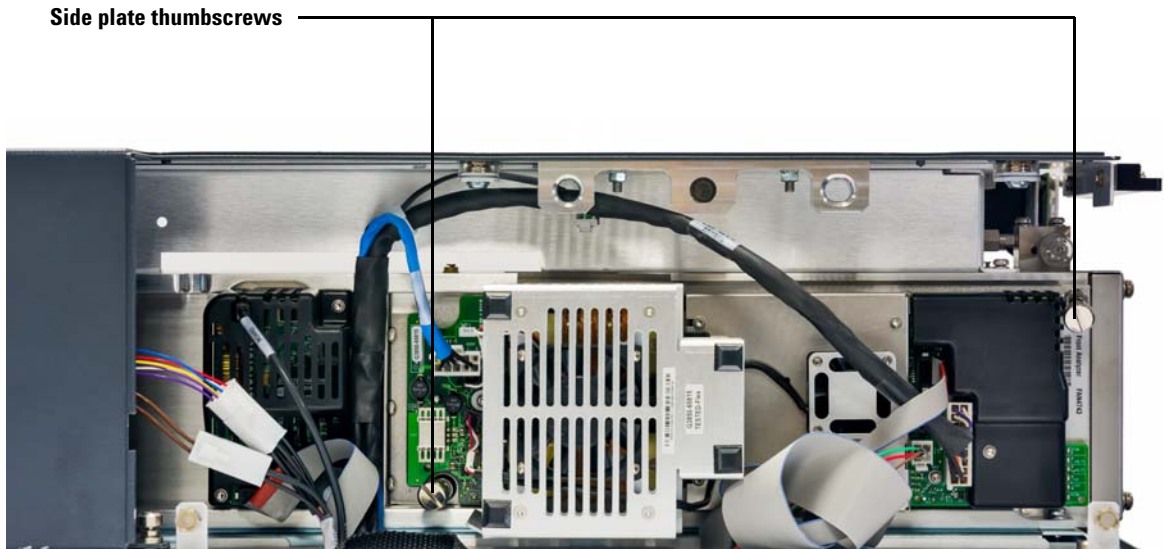


**Figure 8** Analyzer cover

- 11 Finger-tighten the side plate thumbscrews for the analyzer.

**CAUTION**

Do not overtighten the side plate thumbscrews. Overtightening will strip the threads in the analyzer chamber. It will also warp the side plate and cause leaks.



**Figure 9** Side plate thumbscrews

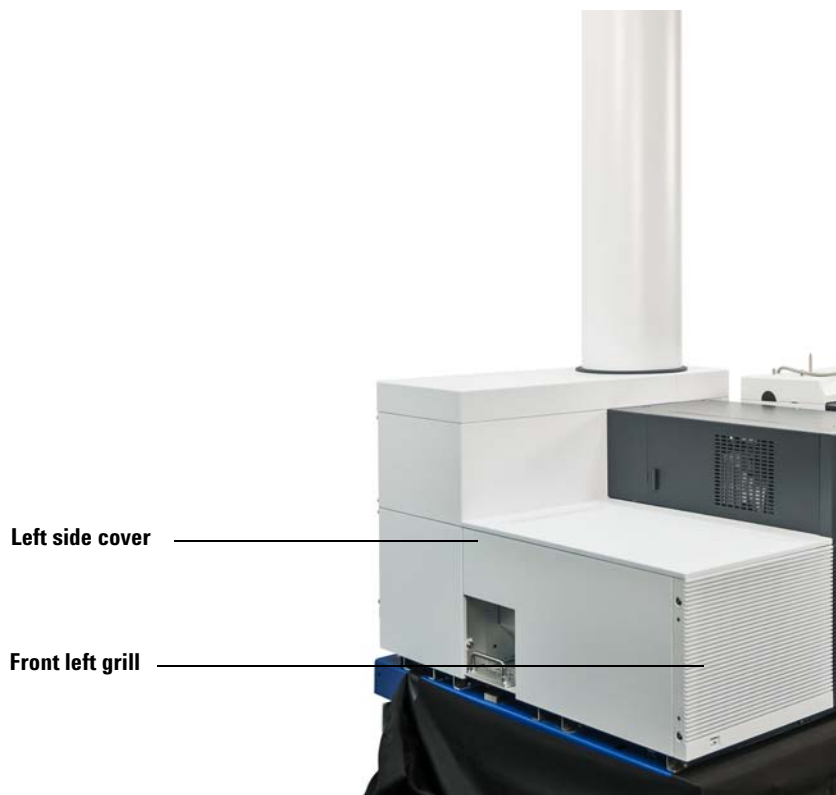
- 12 Reinstall the analyzer cover.
- 13 Remove the front left grill and left side cover. See [“To Access the Left Side Lifting Handle”](#) on page 64. This uncovers the handles on the left side of the instrument.

The MS can now be stored or moved. The MS requires three people for lifting. One for the left side lifting handles, one for the right side lifting handles, and one for the back side lifting handles.

**CAUTION**

The MS must remain upright at all times. If you need to ship your MS to another location, contact your Agilent Technologies service representative for advice about packing and shipping.

## To Access the Left Side Lifting Handle



**Figure 10** Remove covers to access the left side lifting handles

### Materials needed

- Screwdriver, Torx T-10 (8710-1623) or T-20 (8710-1615)

### **WARNING**

The GC/MS interface, the analyzer parts, and the vacuum system operate at temperatures high enough to cause serious burns. Give these parts enough time to cool before accessing them or handling them.



Before performing this procedure, move the GC away from the MS. (See “[To Separate the GC from the MS](#)” on page 57.) Both the GC and MS should be shut down and disconnected from the building power supply. All gas lines must be disconnected from the MS.

This procedure demonstrates how to remove the necessary covers to access the left side lifting handles. The handles on the right and rear sides of the instrument are not covered, and require no special procedures to access.



### Procedure

- 1 To remove the front left grill, disengage the two captive screws on the left side edge of the grill. (See [Figure 11](#).)



**Figure 11** Left front grill captive screws

- 2 Swing the grill open, and remove it by disengaging the cover tabs on the right side.

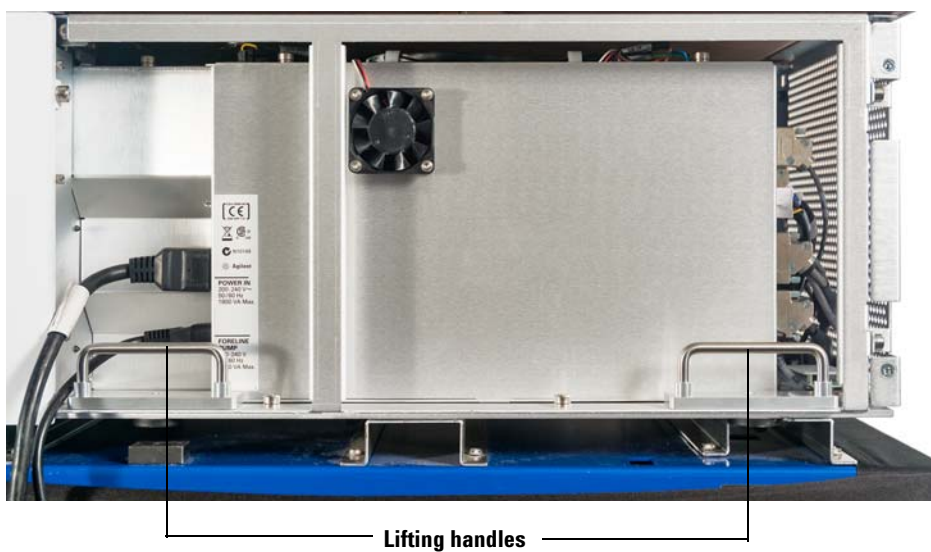
### 3 General Maintenance

- 3 To remove the left side cover, disengage the two captive screws at the front edge of the cover. (See [Figure 12.](#))

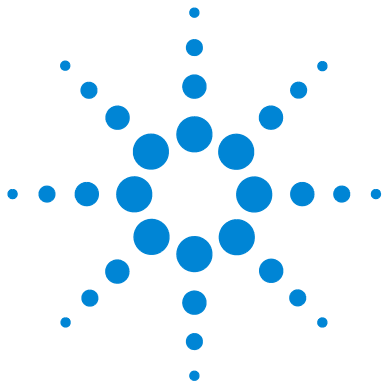


**Figure 12** Left side cover captive screws

- 4 Slide the left side cover towards the front of the instrument.
- 5 Remove this cover to access the handle. (See [Figure 13.](#))



**Figure 13** Left side lifting handles



## 4 Vacuum System

Overview	68
Maintaining the Vacuum System	69
Vacuum System Components	70
Common Vacuum System Problems	71
Foreline Pump	72
Side Plate	83
Vacuum Seals	83
El Calibration Valve	84

This chapter describes maintenance requirements of the Agilent 7250 Accurate Mass Q-TOF GC/MS vacuum system.



### Overview

The vacuum system creates the high vacuum (low pressure) required for the GC/MS to operate. Without the vacuum, the molecular mean free path would be very short and ions would collide with air molecules before they could reach the detector. Operation at high pressures also would damage analyzer components.

The Agilent 7250 Accurate-Mass GC/MS System uses four vacuum pumps to obtain the vacuum levels needed. The Agilent 7250 Accurate-Mass GC/MS System uses three turbomolecular (turbo) pumps to create vacuum in the analyzer. These turbo pumps discharge into a manifold operating at foreline pump inlet pressure. The foreline pump discharges to near atmospheric pressure.

Most of the vacuum system operation is automated. Operator interaction and monitoring is accomplished through the data system.

## Maintaining the Vacuum System

### Periodic maintenance

As listed in [Table 4](#), “Maintenance schedule,” on page 50, some maintenance tasks for the vacuum system must be performed periodically. These include:

- Checking the standard foreline pump fluid (every week)
- Checking the calibration vial (every 6 months)
- Replacing the standard foreline pump oil (every 6 months)
- Replacing IDP tip seal (yearly)
- Replacing IDP filters (yearly)

Failure to perform these tasks as scheduled can result in decreased instrument performance. It can also result in damage to your instrument.

### Other procedures

Problems with any of the vacuum system seals in the analyzer usually require the services of Agilent service personnel. See [Chapter 2](#), “[General Troubleshooting](#)” on page 25, and see the online help in the MassHunter Workstation software for symptoms that indicate this type of maintenance is required.

### More information is available

If you need more information about the locations or functions of vacuum system components, see the *Agilent 7250 Accurate-Mass Q-TOF GC/MS System Operation Manual*.

Most of the procedures in this chapter are illustrated with video clips on the Agilent GC/MS Hardware User Information & Instrument Utilities and 7250 Q-TOF GC/MS User Information disks.

### Vacuum System Components

The parts of the vacuum system are:

- Foreline (rough) pump
- 3 High-vacuum turbo pumps
- Analyzer chambers
- Collision cell connections
- Collision cell plate
- Nitrogen purge and vent system
- Side plate (analyzer door)
- Vacuum seals
- EI calibration valve
- Vacuum control electronics
- Vacuum gauges and gauge control electronics

## Common Vacuum System Problems

### Air leak symptoms

The most common problems associated with any vacuum system are air leaks. Symptoms of air leaks include:

- Loud gurgling noise from the foreline pump (very large leak)
- Inability of the turbo pumps to reach 95% speed
- Higher than normal high-vacuum gauge controller readings

The instrument will *not* pump down successfully unless you press on the side board (analyzer door) when you turn on the MS power. Continue to press until the sound from the foreline pump becomes quieter.

### Pumpdown failure shutdown

The system will shut down both the high-vacuum and the foreline pump if the system fails to pump down correctly. It takes approximately 10 minutes for the foreline pump to achieve 10 Torr, which then allows the turbo pumps to start. If a turbo pump speed is below 80% after an additional 10 minutes, the system shuts down.

This is usually because of a *large* air leak: either the side plate has not sealed correctly or the electronic vent valve is still open.

To restart the MS, find and correct the air leak, then switch the power off and on. Press on the side plates when turning on the MS power to ensure good seals.

## Foreline Pump

The 7250 can be used with either a standard oil based foreline pump, or a dry scroll pump. Procedures for maintaining these pumps are provided on the following pages.

### Standard foreline pump

This section lists procedures to maintain the standard foreline pump. They should be performed according to the maintenance schedule or as indicated by instrument symptoms.



**Figure 14** Standard foreline pump



## To connect the foreline hose to the foreline pump

### Materials needed

- Gloves, clean, lint-free
  - Large (8650-0030)
  - Small (8650-0029)



### Procedure

This procedure shows the IDP-15 pump, but also applies to the DS-202 pump.

- 1 Place the o-ring against the hepa filter inlet.
- 2 Place the foreline hose against the o-ring.
- 3 Place the clamp over the o-ring, hose flange, and filter flange.
- 4 Tighten the clamp using the long screw and wing nut.

## To disconnect the foreline hose from the foreline pump

### Materials needed

- Gloves, clean, lint-free
  - Large (8650-0030)
  - Small (8650-0029)



### Procedure

This procedure shows the IDP-15 pump, but also applies to the DS-202 pump.

- 1 Unscrew the wing nut on the clamp.
- 2 While supporting the foreline hose, remove the clamp from the hepa filter inlet.
- 3 Remove the hose and o-ring from the filter inlet.

### To check the oil mist filter

Check the oil mist filter weekly for any damage and collected pump fluid.

- If the oil mist filter is damaged, replace it.
- If oil is found in the oil mist filter, open the gas ballast valve counterclockwise just enough to return the condensed oil back to the pump. Close the gas ballast valve clockwise.

### WARNING

**Do not touch the fluid. The residue from some samples are toxic. Properly dispose of the fluid.**

---

### NOTE

When you close the ballast valve, you increase the efficiency of the pump. However, you lose oil to the mist filter if you don't recycle. Check the status of your oil mist filter at least once per week to ensure that it does not fill with oil. If you lose too much oil in the foreline pump, the vacuum will not be maintained, and the MS will vent.

---

### To check the foreline pump fluid level

Check the level and color of the pump fluid weekly.

- Check the fluid level in the window of the foreline pump. The fluid level should be between the marks for Max and Min.
- Check that the color of the pump fluid is clear or almost clear with few suspended particles. If the pump fluid is dark or full of suspended particles, replace it.

### WARNING

**Never add or replace the foreline pump fluid while the pump is on.**

---

### NOTE

Record this procedure in the Maintenance Logbook, which was supplied with your instrument.

---

### To add foreline pump fluid

Add pump fluid when the pump fluid level is low.

#### Materials needed

- Funnel
- Gloves, clean, lint-free
  - Large (8650-0030)
  - Small (8650-0029)
- Foreline pump fluid (Inland 45 oil, p/n 6040-0834)
- Safety glasses (goggles)

**WARNING**

Never add pump fluid while the pump is on.

**WARNING**

The fill cap and pump may be dangerously hot. Check that the fill cup and pump are cool before you touch them.

**CAUTION**

Use only Foreline pump fluid (Inland 45 oil, p/n 6040-0834). Any other fluids can substantially reduce pump life and invalidates the pump warranty.

#### Procedure

- 1 Vent and turn off the instrument. See the *Agilent 7250 Accurate-Mass Q-TOF GC/MS System Operation Manual*.
- 2 Unplug the instrument power cord from the electrical outlet.
- 3 Remove the fill cap on the foreline pump.
- 4 Add new pump fluid until the fluid level is near, but not over the maximum mark beside the fluid level window.
- 5 Reinstall the fill cap.
- 6 Wipe off all excess oil around and underneath of the pump.
- 7 Reconnect the power cord.
- 8 Start up the instrument. See the *Agilent 7250 Accurate-Mass Q-TOF GC/MS System Operation Manual*.

### To replace the foreline pump fluid

Replace the pump fluid every six months or sooner if the fluid appears dark or cloudy.

#### Materials needed

- Container for catching old pump fluid
- Funnel
- Gloves, clean, lint-free
  - Large (8650-0030)
  - Small (8650-0029)
- Rough pump fluid (Inland 45 oil, p/n 6040-0834)
- Screwdriver, flat-bladed, large (p/n 8710-1029)
- Safety glasses (goggles)

#### WARNING

**Never add pump fluid while the pump is on.**

#### WARNING

**The fill cap and pump may be dangerously hot. Check that the fill cap and pump are cool before you touch them.**

#### WARNING

**Do not touch the fluid. The residue from some samples are toxic. Properly dispose of the fluid.**

#### CAUTION

Use only Foreline pump fluid (Inland 45 oil, p/n 6040-0834). Any other fluids can substantially reduce pump life and invalidates the pump warranty.



#### Procedure

- 1 Turn off the instrument. See the *Agilent 7250 Accurate-Mass Q-TOF GC/MS System Operation Manual*.
- 2 Unplug the power cord from the instrument.
- 3 Place a container under the drain plug of the foreline pump.

- 4 Remove the fill cap, then open the drain plug. Drain the fluid completely by raising the motor end of the pump up.
- 5 Reinstall the drain plug.
- 6 Pour in new pump fluid until the fluid level is near, but not above the maximum mark beside the fluid level window.
- 7 Reinstall the fill cap.
- 8 Reconnect the power cord.
- 9 Start up the instrument. See the *Agilent 7250 Accurate-Mass Q-TOF GC/MS System Operation Manual*.
- 10 Pump down for 30 minutes, then inspect the pump for leaks.
- 11 Continue pumping down overnight and inspect the pump for leaks the next day.

#### **The oil pan under the foreline pump can be a fire hazard**

Oily rags, paper towels, and similar absorbents in the oil pan could ignite and damage the pump and other parts of the MS.

### **WARNING**

**Combustible materials (or flammable/nonflammable wicking material) placed under, over, or around the foreline (roughing) pump constitutes a fire hazard. Keep the pan clean, but do not leave absorbent material such as paper towels in it.**

---

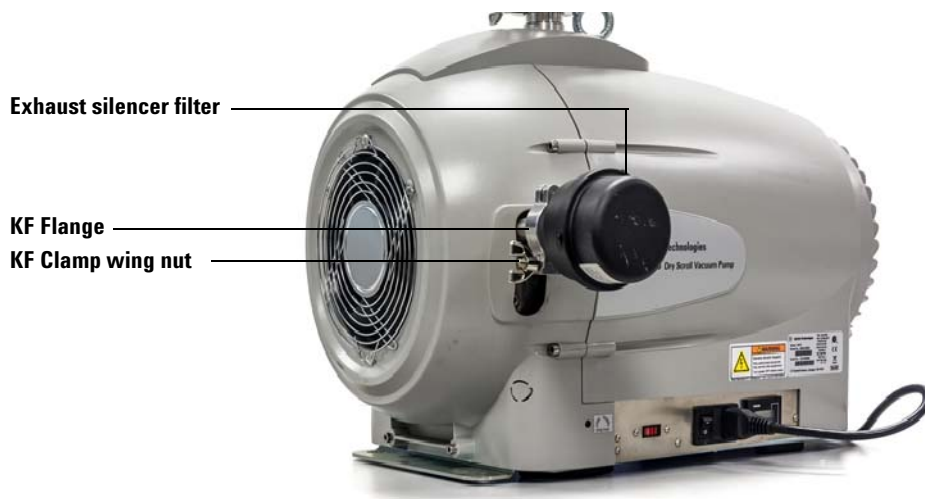
#### **To remove the foreline pump exhaust silencer filter**



##### **Procedure**

This procedure shows the IDP-15 pump, but also applies to the DS-202 pump.

- 1 Remove the KF clamp wing nut. (See [Figure 15](#), “Foreline pump exhaust silencer filter,” on page 78.)
- 2 Support the exhaust silencer filter and remove the bolt, KF clamp, and centering O-ring.



**Figure 15** Foreline pump exhaust silencer filter

### To Install the foreline pump exhaust silencer filter



#### Procedure

This procedure shows the IDP-15 pump, but also applies to the DS-202 pump.

- 1 Place the centering o-ring against the foreline pump exhaust KF flange. (See [Figure 15](#).)
- 2 Place the exhaust silencer filter against the centering O-ring.
- 3 Place the KF clamp over the centering O-ring and KF flanges.
- 4 Insert the bolt into the KF clamp, and fasten the clamp with the wing nut.

## IDP-15 foreline pump



**Figure 16** IDP-15 foreline pump

### To replace the IDP-15 tip seal

#### Materials needed

- Gloves, clean, lint-free
  - Large (8650-0030)
  - Small (8650-0029)
- 4 mm hex wrench (8710-2720)
- 5 mm hex wrench (G4514-80524)
- 6 mm hex wrench (8710-1839)
- IDP-15 tip seal maintenance kit (5190-9613)



#### Procedure

- 1 Using a 4 mm hex wrench, unscrew the six screws securing the front cowl.
- 2 Rotate the cowl over the exhaust port.
- 3 Unplug the fan connector at the base of the cowl, and remove the cowl.
- 4 Set aside the L-bracket.

- 5 Using a 5 mm hex wrench, unscrew the six screws securing the outboard housing. It may be necessary to raise and support the top console to access the screws.
- 6 Remove the O-ring.
- 7 Remove both tip seals from the orbiting plate and the outboard housing.
- 8 Use cotton swabs dampened with alcohol to clean all debris from the orbiting plate, outboard housing, and O-ring groove.
- 9 Install the new O-ring.
- 10 Install the new tip seals into the grooves in the orbiting scroll and outboard housing. The tip seal should be well seated in the grooves, protruding only slightly from the grooves.
- 11 Align the outboard housing with the orbiting plate, and reattach it using the six screws and a 5 mm hex wrench. When tightening the screws, do so in a crisscross pattern as shown.
- 12 Reinstall the console.
- 13 Align the slots in the L-bracket with the holes in the electrical tray.
- 14 Reconnect the fan connector.
- 15 Rotate the front cowl over the exhaust port, and align it on the front of the pump.
- 16 Reattach the front cowl using the six screws and a 4 mm hex wrench.

### To replace the hepa filter cartridge

#### Materials needed

- Gloves, clean, lint-free
  - Large (8650-0030)
  - Small (8650-0029)
- Hepa filter with cartridge (SCRINTRPNW25)
- Hepa filter cartridge (REPLHEPAFILTER1)



#### Procedure

- 1 Undo the three latches securing the top of the hepa filter.
- 2 Remove the lid, and the filter cartridge from the filter.
- 3 Insert the new filter cartridge, and replace the lid on top of the filter.



- 4 Secure the lid using the three latches.

### To change the exhaust silencer filter cartridge

#### Materials needed

- Gloves, clean, lint-free
  - Large (8650-0030)
  - Small (8650-0029)
- Exhaust silencer filter cartridge
  - large (REPLSLRFILTER1)



#### Procedure

This process can be used for all filter sizes.

- 1 Unscrew the cap from the exhaust filter.
- 2 Pull the filter cartridge out of the filter cap.
- 3 Insert the new filter cartridge.
- 4 Align the cap onto the filter and twist the cap counter clockwise to lock it in place.

### To install the ballast

#### Materials needed

- 4 mm hex wrench (8710-2720)
- 6 mm hex wrench (8710-1839)
- 14 mm wrench
- Ballast (Contact Agilent for this part)



#### Procedure

- 1 Using a 4 mm hex wrench, unscrew the six screws securing the front cowl.
- 2 Rotate the cowl over the exhaust port.
- 3 Unplug the fan connector at the base of the cowl, and remove the cowl.
- 4 Using a 6 mm hex wrench, remove the ballast plug from the desired gas ballast port.

- 5 Screw the ballast into the empty port, and tighten it with a 14 mm wrench.

### To remove the ballast

#### Materials needed

- 4 mm hex wrench (8710-2720)
- 6 mm hex wrench (8710-1839)
- 14 mm wrench
- Ballast plug (Contact Agilent for this part)



#### Procedure

- 1 Using a 4 mm hex wrench, unscrew the six screws securing the front cowl.
- 2 Rotate the cowl over the exhaust port.
- 3 Unplug the fan connector at the base of the cowl, and remove the cowl.
- 4 Using a 14 mm wrench, loosen the ballast until it can be removed by hand.
- 5 Unscrew and remove the ballast.
- 6 Using a 6 mm hex wrench, install the ballast plug.

## Side Plate

The side plate covers the large opening in the side of the analyzer chamber. The analyzer assembly is attached to the side plate inside the analyzer chamber.

Several electrical feedthroughs are built into the side plate. Wires connect the feedthroughs to analyzer components.

Thumbscrews are located at each end of the side plate. We recommend that the thumbscrews be loosely tightened

### CAUTION

Fasten the side plate thumbscrews for shipping or storage only. For normal operation, both thumbscrews should be loose. Overtightening will warp the side plate and cause air leaks. Do not use a tool to tighten the side plate thumbscrews.

---

### CAUTION

When you turn on the power to pump down the MS, press on the side board to ensure good seals.

---

## Vacuum Seals

Several types of Viton elastomer O-ring seals are used to prevent air leaks into the analyzer chamber. All these O-rings, and the surfaces to which they seal, must be kept clean and protected from nicks and scratches. A single hair, piece of lint, or scratch can produce a serious vacuum leak. Three of the O-rings are *lightly* lubricated with Apiezon-L vacuum grease: the side plate O-rings and the vent valve O-ring.

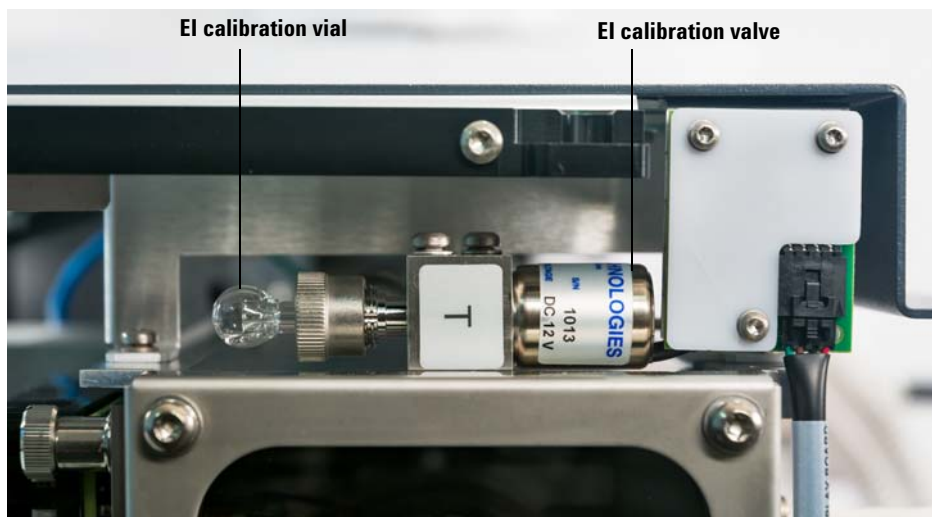
Contact Agilent to have these vacuum seals serviced.

## EI Calibration Valve

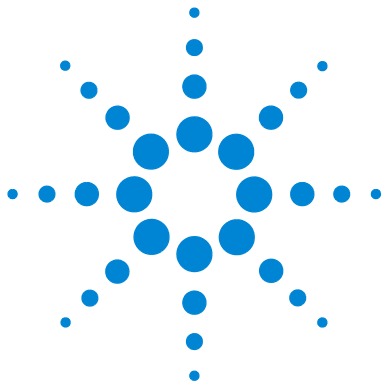
The EI calibration valve is an electromechanical valve with a vial to hold the tuning compound. (See [Figure 17](#).) When a calibration valve is opened, tuning compound in the vial diffuses into the ion source. The valve is controlled by the MassHunter Workstation software.

The EI calibration valve is held onto the top of the analyzer chamber by two screws. A small O-ring provides a face seal.

Perfluorotributylamine (PFTBA) is the most commonly used tuning compound for EI operation. PFTBA is required for automatic tuning of the MS.



**Figure 17** El calibration valve



## 5 Replacement Parts

To Order Parts	86
Electronics	87
Vacuum System	90
Analyzer	94
GC/MS Transferline interface for the 7890 GC	98
Consumables and Maintenance Supplies	100

This chapter lists parts that can be ordered for use in maintaining your 7250 Accurate-Mass Q-TOF GC/MS System. It includes most of the parts or assemblies in the MS.

Most of the parts listed are not user-replaceable. They are listed here for use by Agilent Technologies service representatives.



### To Order Parts

To order parts for your MS, address the order or inquiry to your local Agilent Technologies office. Supply them with the following information:

- Model and serial number of your MS, located on a label near the power cord connections to the mainframe.
- Part number(s) of the part(s) needed
- Quantity of each part needed

### Some parts are available as rebuilt assemblies

Rebuilt assemblies pass all the same tests and meet all the same specifications as new parts. Rebuilt assemblies can be identified by their part numbers. The first two digits of the second part of the part number are 69 or 89 (such as xxxxx-69xxx or xxxxx-89xxx). Rebuilt assemblies are available on an exchange-only basis. When you return the original part to Agilent Technologies (after you receive the rebuilt assembly) you will receive a credit.

### If you cannot find a part you need

If you need a part that is not listed in this chapter, check the Agilent Technologies Analytical Supplies Catalog or the online catalog on the Worldwide Web at <http://www.agilent.com/chem>. If you still cannot find it, contact your Agilent Technologies service representative or your Agilent Technologies office.

## Electronics

The printed circuit boards in the MS are available only as complete assemblies. Individual electronic components are not available. This section contains the following parts: [Table 5](#), “External cables”; [Table 6](#), “Internal cables,” on page 88; [Table 7](#), “Printed circuit boards,” on page 88; and [Table 8](#), “Fuses and power switches,” on page 89.

### Cables

**Table 5** External cables

Description	Part number
Remote Start-Stop cable	G1530-60930
Y Remote Start-Stop cable	G1530-61200
H Remote Start-Stop cable	35900-60800
MS LAN cable	8121-2846
LAN cable	8121-0940
<b>C19 Q-TOF Mainframe</b>	
Power cord, Taiwan/S America, C19, 20 A	8120-6360
Power cord, Japan, C19, 20 amp	8120-6903
Power cord, Australia, C19, 16 amp	8120-8619
Power cord, GB/HK/SG/MY, C19, 13 amp	8120-8620
Power cord, Swiss/DK, C19, 16 amp	8120-8622
Power cord, China, C19, 15 amp, fast	8121-0070
Power cord, Israel, C19, 16 amp	8121-0161
Power cord, Argentina, C19, 16 amp	8121-0675
Power cord, India/S.Africa, C19, 15 amp	8121-0710
Power cord, Europe/S Korea, C19, 15 A, 250 V	8121-1222
Power cord, Thai 220 V, 15 A, 1.8 M, C19	8121-1301

## 5 Replacement Parts

**Table 5** External cables (continued)

<b>Description</b>	<b>Part number</b>
Power cord, Brazil, C19, 250 V max	8121-1787
Power cord, US 240 V, C19, 15 amp	8121-0075

**Table 6** Internal cables

<b>Description</b>	<b>Part number</b>
Cable, Switch board	G3850-60819
Cable, Quad driver-1 data	G3850-60802
Cable, Collision cell board data	G3850-60848
Cable, Filament drive board data	G3850-60847
Cable harness, main board 1	G3850-60826
Cable harness, main board 2	G3850-60855
Cable, Gauge 3 extension	G3850-60836
Cable, Turbo supply	G3850-60810
Cable, Turbo controller module data	G3850-60824
Cable, Turbo fan and turbo fan controller	G3850-60811
Cable, Turbo pump control module, AC	G3850-60825
Cable, Wire lens - 5	G3850-60833
Cable, Rough pump AC output	G3850-60837

## Printed circuit boards

**Table 7** Printed circuit boards

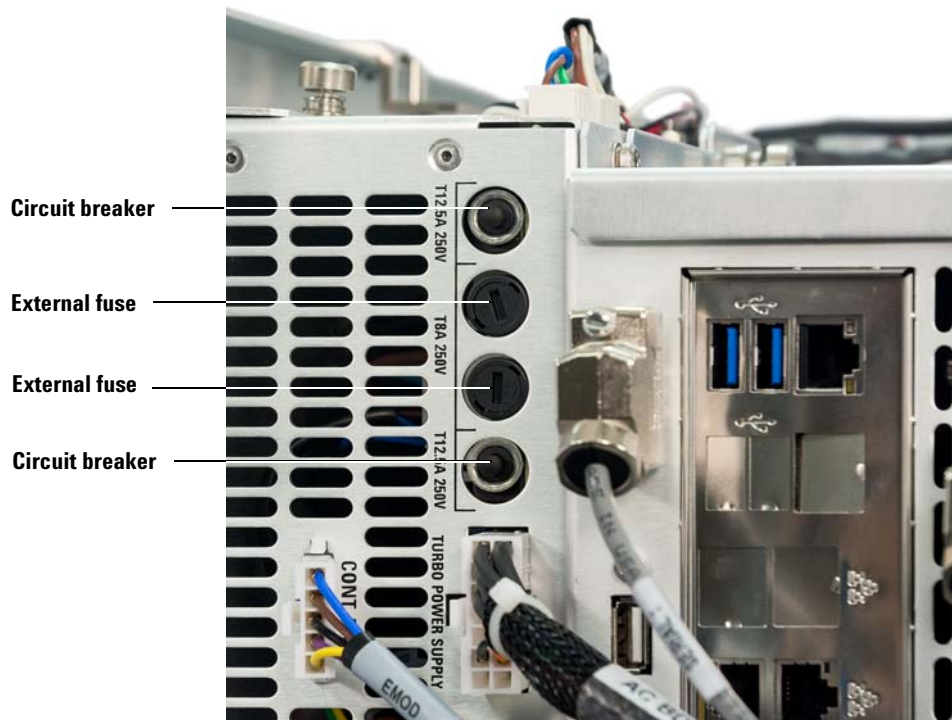
<b>Description</b>	<b>Part number</b>
Filament drive board	G7000-67018
Collision cell board	G7000-65814



## Fuses and power switch

**Table 8** Fuses and power switches

Description	Part number
Fuse - AC Board	G1960-6117
Fuse (main frame) metric 8 A 250 V TD FE UL-REC CSA	2110-0969
Fuse (rough pump) metric 12.5 A 250 V UL-LST CSA	2110-1398
Switch Bd PCA	G1960-61000
Power switch button	5041-8381
Switch board cable	G3850-60819



**Figure 18** 7250 Fuses

## Vacuum System

This section contains the following parts: [Table 9](#), “O-rings and seals”; [Table 10](#), “Foreline pump and related parts,” on page 91; [Table 11](#), “IDP-15 Pump and related parts,” on page 91; and [Table 12](#), “Turbo pump MS vacuum system components,” on page 92.

### O-rings and seals

**Table 9** O-rings and seals

Description	Part number
Calibration valve O-ring (1/4-inch)	5180-4182
End plate O-ring (for front and rear end plates)	0905-1441
GC/MS interface O-ring	0905-1405
KF10/16 seal (foreline pump inlet and turbo pump outlet)	0905-1463
KF25 O-ring assembly (turbo pump outlet)	0100-1551
Seal, turbo pump inlet	0100-1879
O-ring, forepump drain plug	0905-1619
Fill plug, forepump	0100-2451
Analyzer ion gauge	G1960-80303
Foreline ion gauge	G1960-80101
O-ring, standard forepump fill plug	0905-1630
O-ring, ion gauge	0905-1627
O-ring, collision cell feedthrough	0905-1405
O-ring, collision cell plate	0905-1689
Side plate O-ring	0905-1690

## Foreline pump DS-202 and related parts

**Table 10** Foreline pump and related parts

Description	Part number
Foreline hose assembly (hose and internal spring)	05971-60119
Hose clamp used with 05971-60119	1400-3241
DS 202 foreline pump, 240V	G3850-80240
Oil return kit	9499376
Oil mist eliminator kit for KF25	9499392
Oil drain extension	9499375
Aluminum centering ring, with viton o-ring	KC25AV
Foreline pump inlet seal (KF10/16)	0905-1463
KF25 Clamp (tp end of hose – not shown)	0100-0549
KF25 Hose adapter (tp end of hose – not shown)	G1099-20532
O-ring for oil mist filter and hose barb adapter	0905-1193

## IDP-15 dry foreline pump and related parts

**Table 11** IDP-15 Pump and related parts

Description	Part number
IDP-15 tip seal maintenance kit	5190-9613
IDP-15 tip seal replacement kit	X3815-67000
IDP-15 pump	X3815-64010
Hepa filter	SCRINTRPNW25
Exhaust silencer kit	EXSLRSH110
Ballast	Contact Agilent for this part
Ballast plug	Contact Agilent for this part

## Turbo pump and related parts

**Table 12** Turbo pump MS vacuum system components

<b>Description</b>	<b>Part number</b>
Fan (for high-vacuum pump)	G1099-60564
Pfeiffer HiPace300, rebuilt	G3170-89162
Pfeiffer HiPace300	G3170-80162
KF25 Clamp (for turbo pump outlet)	0100-0549
KF25 O-ring assembly (for turbo pump outlet)	0100-1551
Split flow turbo pump, nEXT200.200D	G3850-80010
Split flow turbo pump, nEXT200.200D, rebuilt	G3850-89010
ISO100 seals	3150-0962
Claw assembly	G3170-60580
Flat washers	3050-0993
Lock washers	2190-0669
Hex nuts	0535-0048
Half claw clamp	G3170-60580
Centering ring, NW25, with o-ring	0100-1551
O-ring, trapped	0905-1463
O-ring	0905-1574
O-ring	0905-1573
O-ring, backup	G1969-20082
Hinged clamp with wing nut, NW20/25	0100-1398
Cable, extension	G3850-60800
Flex hose, metal, NW 25	G3850-20156
Thermal barrier	G1969-20081
Power supply, TMH	G3850-60600
CC gas flow module, 3-channel	G7002-60044

**Table 12** Turbo pump MS vacuum system components (continued)

Description	Part number
GC/MS QQQ flow weldment cap assembly	G7000-80500
3-Channel QQQ EPC	G7000-60506

## Analyzer

Table 13 shows the analyzer chambers and associated parts.

**Table 13** Analyzer chamber and related parts

Description	Part number
Micro Ion Gauge	G1960-80303
Ion gauge baffle	G7000-20049
O-ring, ion gauge	0905-1627
M3x12L screws	0515-0664
EI Calibration valve assembly	G3850-67204
Calibration vial	G3170-80002
Collision cell holder	G3850-20042

Table 14 shows the replacement parts for the analyzers. Also included in this section are Table 15, “Analyzer screws,” on page 95; and Table 16, “Parts list for LE-EI ion source,” on page 96.

**Table 14** Analyzer parts

Description	Part number
Source PCA and cable assembly	G7002-60425
Mass filter cable kit	G3170-60130
Mass filter contacts (qty 1)	G1099-60142
Mass filter ceramic support, source end	G7002-20057
Mass filter heater assembly	G1099-60172
Pins for source and detector end mounting brackets	G1099-20137
p-filter bridge	G7000-60028
Side plate, weld assembly (support)	G7002-67021

**Table 15** Analyzer screws

<b>Description</b>	<b>Part number</b>
Heater/Sensor (quad) assembly	G1099-60172
Ion source thumbscrew	G1099-20138
Magnet mounting screws	0515-1046
Screw – magnet bracket to source radiator	0515-1602
Screws – mass filter contact assembly/heater block	G3170-20122
Screws – radiator. Mounting brackets quadrupole board	0515-0430
Source radiator screws	0515-1052
Screws for Quad Stop	0515-0221

## The LE-EI Ion Source

A list of the replacement parts related to the LE-EI ion source may be found in [Table 16](#) and an illustration of the parts is also provided in [Figure 19](#), “LE-EI ion source,” on page 97.

**Table 16** Parts list for LE-EI ion source

	Description	Part number
1	Source finger grip	G7002-20008
2	Filament block	G7002-20019
3	Extractor lens (5) <sup>*</sup> , with 3 mm opening	G7002-20061
4	Ceramic insulator for extractor	G7002-20064
5	Entrance lens (1) <sup>*</sup>	G7002-20065
6	Ion focus lens (2) <sup>*</sup>	G7002-20068
7	Lens insulator/holder	G7002-20074
8	M2 x 0.4 screw x 12 mm long gold plated screw	G7002-20083
9	Source body	G7002-20084
10	Post extractor lens 2 (3) <sup>*</sup>	G7002-20090
11	Post extractor lens 1 (4) <sup>*</sup>	G7002-20104
12	M2 x 6 mm gold plated screw	G7002-20109
13	Locking ring lens insulator	G7002-20126
14	Filament assembly, HE, single	G3850-60021
15	Ring heater/sensor assembly	G7002-60043
16	Source mount	G7002-60053
17	Repeller assembly	G7002-67057
Complete assembly	Ion source assy, LE-EI 7250A	G3850-67070

\* The number in parenthesis is the number engraved on the lens



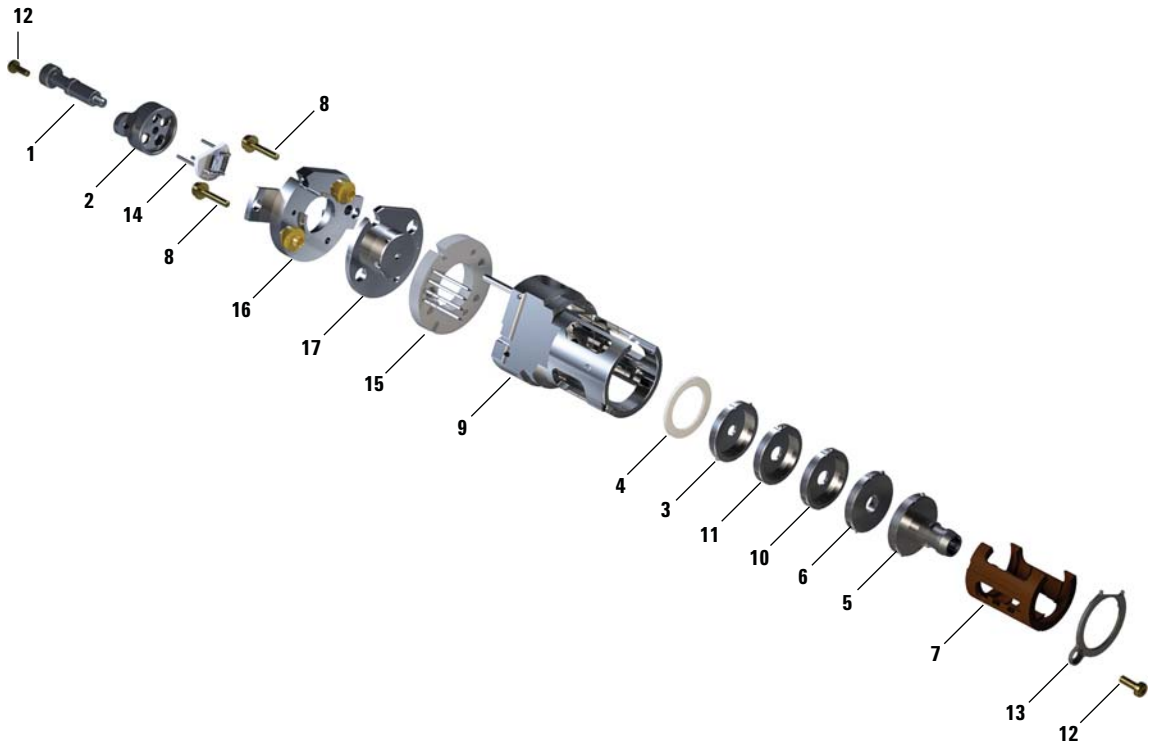


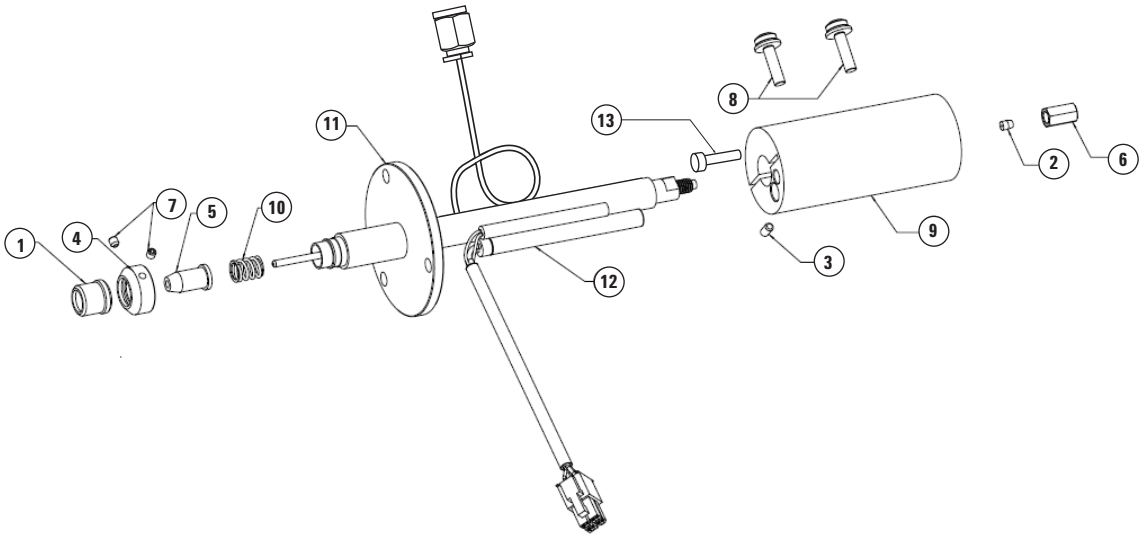
Figure 19 LE-EI ion source

## GC/MS Transferline interface for the 7890 GC

A list of the replacement parts related to the GC/MS transferline interface for the 7890 GC and an illustration of the parts is also provided. (See [Table 17](#) and [Figure 20](#), “GC/MS Transferline interface for the 7890 GC,” on page 99.)

**Table 17** GC/MS transferline interface for 7890

Item	Description	Part number
	Transferline assembly	Contact Agilent for this part
1	Transferline tip cap, threaded	G3870-20547
2	1/16 Ferrule no hole graphitized Vespel	0100-0691
2	1/16 Ferrule no hole (qty 10)	5181-3308
3	M3 x 3L Set screw, gold plated	G1999-20022
4	Transferline tip base, threaded	G3870-20548
5	Transfer tip	G3870-20542
6	Self Tightening Column Nut	5190-5233
6	MS interface column nut	05988-20066
7	MS screw	G1999-20022
8	M4 X 0.7 16MM-LG	0515-0383
9	Heater clamp	G3850-20410
10	Transfer line spring	G1999-20023
11	Welded interface assembly	G3870-60301
12	Heater/sensor assembly	G1099-60107
13	M3 set screw	0515-0236
not shown	Fitting-face seal, 1/4 in cap sst 316	0100-2013
not shown	VCR gasket, size 4, AG on Ni retainer	0100-1436



**Figure 20** GC/MS Transferline interface for the 7890 GC

## Consumables and Maintenance Supplies

This section contains the following parts: [Table 18](#), “EI maintenance supplies”; [Table 19](#), “Tools”; [Table 20](#), “Ferrules,” on page 101; and [Table 21](#), “Miscellaneous parts and samples,” on page 102.

**Table 18** EI maintenance supplies

Description	Part number
Abrasive paper, 30 µm	5061-5896
Aluminum oxide powder, 100 g	393706201
Cloths, clean (qty 300)	05980-60051
Cloths, cleaning (qty 300)	9310-4828
Cotton swabs (qty 100)	5080-5400
Foreline pump oil, Inland 45	6040-0834
Gloves, clean – Large	8650-0030
Gloves, clean – Small	8650-0029
Grease, Apiezon L, high vacuum	6040-0289

**Table 19** Tools

Description	Part number
Column insertion tool	G3850-60014
Funnel	9301-6461
Hex key, 5 mm	8710-1838
Tool kit	G7077-60566
Ball drivers, 1.5-mm	8710-1570
Ball drivers, 2.0-mm	8710-1804
Ball drivers, 2.5-mm	8710-1681
Hex nut driver, 5.5-mm	8710-1220

**Table 19** Tools (continued)

<b>Description</b>	<b>Part number</b>
Pliers, long-nose (1.5-inch nose)	8710-0004
Screwdrivers Flat-blade, large	8730-0002
Screwdrivers Torx, T-10	8710-1623
Screwdrivers Torx, T-15	8710-1622
Screwdrivers Torx, T-20	8710-1615
MS shipping kit	G7077-60502
Gas clean filter kit for carrier gas	CP17974
GC-Q-TOF MSD ship kit, EPC-BF	G7250-60180
Tweezers, non-magnetic	8710-2460
Wrenches, open-end 1/4-inch × 5/16-inch	8710-0510
Wrenches, open-end 10-mm	8710-2353
Wrist strap, antistatic, small	9300-0969
Wrist strap, antistatic, medium	9300-1257
Wrist strap, antistatic, large	9300-0970

**Table 20** Ferrules

<b>Description</b>	<b>Part number</b>
For the GC/MS interface	
• Blank, graphite-vespel	5181-3308
• 0.3-mm id, 85%/15% for 0.10-mm id columns	5062-3507
• 0.4-mm id, 85%/15%, for 0.20 and 0.25-mm id columns	5062-3508
• 0.5-mm id, 85%/15%, for 0.32-mm id columns	5062-3506
• 0.8-mm id, 85%/15%, for 0.53-mm id columns	5062-3538
For the GC inlet	

**Table 20** Ferrules (continued)

Description	Part number
• 0.27-mm id, 90%/10%, for 0.10-mm id columns	5062-3518
• 0.37-mm id, 90%/10%, for 0.20-mm id columns	5062-3516
• 0.40-mm id, 90%/10%, for 0.25-mm id columns	5181-3323
• 0.47-mm id, 90%/10%, for 0.32-mm id columns	5062-3514
• 0.74-mm id, 90%/10%, for 0.53-mm id columns	5062-3512

**Table 21** Miscellaneous parts and samples

Description	Part number
Collision cell gas flow module, 3-channel	G7002-60044
GC/MS quadrupole flow weldment cap assy	G7000-80500
Quadrupole EPC module, 3-channel	G7000-60506
Octafluoronaphthalene, OFN, 1 pg/μL	5188-5348
Octafluoronaphthalene, OFN, 100 fg/μL	5188-5348
Benzophenone, 100 pg/μL	8500-5440
PFTBA sample kit	05971-60571
Rough pump oil pan	G1946-00034
Eval A, hydrocarbons	05971-60045
Micro-Ion gauge electronics	G3170-89001
J20' 1/8-inch id stainless steel	7157-0210
Wipes (qty 300)	9310-4828
Swagelok ferrule, front, 1/8-inch, 10/package	5180-4110
Swagelok ferrule, rear, 1/8-inch, 10/package	5180-4116
Swagelok nut, for 1/8-inch fitting, 10/package	5180-4104
Swagelok nut and ferrules, 10 set/package	5080-8751

**Table 21** Miscellaneous parts and samples (continued)

Description	Part number
Tubing cutter for SS tubing	8710-1709
Tubing cutter replacement blades	8710-1710

## **5 Replacement Parts**







**Agilent Technologies**

© Agilent Technologies, Inc.

Printed in USA, July 2017



**G7250-90001**