



OPERATING INSTRUCTIONS

EN

Translation of the original instructions

HIPACE 300 PLUS

Turbopump

PFEIFFER  **VACUUM**

Table of contents

1	About this manual	4
1.1	Validity	4
1.1.1	Applicable documents	4
1.2	Conventions	4
1.2.1	Safety instructions	4
1.2.2	Pictographs	5
1.2.3	Instructions in the text	5
1.2.4	Abbreviations	5
1.2.5	Symbols used	5
2	Safety	6
2.1	Safety precautions	6
2.2	Protective equipment	7
2.3	Proper use	7
2.4	Improper use	8
3	Transport and storage	9
3.1	Transport	9
3.2	Storage	9
4	Product description	10
4.1	Product identification	10
4.1.1	Pump types	10
4.1.2	Pump features	10
4.1.3	Scope of delivery	10
4.2	Function	11
4.2.1	Cooling	11
4.2.2	Rotor bearing	11
4.2.3	Drive	11
4.3	Range of application	12
5	Installation	13
5.1	Preparatory work	13
5.2	Set-up	13
5.2.1	Earthquake safety	14
5.2.2	Use of a splinter shield or protection screen	14
5.2.3	Vibration damper	14
5.3	Mounting orientation	15
5.4	Connecting the high vacuum side	16
5.4.1	Installation of ISO-K flange with ISO-K flange	16
5.4.2	Installation of ISO-K flange with ISO-F flange	17
5.4.3	Installation of ISO-F with ISO-F flange	18
5.4.4	Installation of CF- flanges	19
5.5	Connecting the fore-vacuum side	20
5.6	Connections to the turbopump	21
5.6.1	Electronic drive unit	21
5.6.2	Earthing	21
5.6.3	Power and electrical supply	21
5.7	Accessory connection	22
5.7.1	Air cooling	23
5.7.2	Venting valve	23
5.7.3	Heating jacket	24
5.7.4	Sealing gas connection	25
5.7.5	Water cooling	26
6	Operation	27

6.1	Commissioning	27
6.2	Operation modes	27
6.3	Function description	27
6.3.1	Operation without operating unit	28
6.3.2	Operation via "X3" connection	28
6.3.3	Operation with DCU or HPU	28
6.3.4	Operation via fieldbus	28
6.4	Monitoring of the operation conditions	28
6.4.1	Temperature monitoring	28
6.4.2	Operation display via LED	28
6.5	Switching off and venting	29
6.5.1	Switching off	29
6.5.2	Venting	29
7	Maintenance / replacement	30
7.1	Maintenance intervals and responsibilities	30
7.2	Replacing the operating fluid reservoir	30
7.3	Replacing the electronic drive unit	31
7.3.1	Rotation speed set value	32
8	Decommissioning	33
8.1	Shutting down for longer periods	33
8.2	Re-starting	33
8.3	Disposal	33
9	Malfunctions	34
9.1	Rectifying malfunctions	34
10	Service	35
11	Spare parts HiPace 300 Plus	36
12	Accessories	37
13	Technical data and dimensions	39
13.1	General	39
13.2	Technical data	40
13.3	Dimensions	41
	Declaration of conformity	42

1 About this manual

1.1 Validity

This operating manual is for customers of Pfeiffer Vacuum. It describes the functioning of the designated product and provides the most important information for safe use of the unit. The description follows applicable EU guidelines. All information provided in this operating manual refers to the current state of the product's development. The documentation remains valid as long as the customer does not make any changes to the product.

Up-to-date operating instructions can also be downloaded from www.pfeiffer-vacuum.com.

1.1.1 Applicable documents

HiPace 300 Plus, depending on the model	Operating instructions
Operating instructions "Electronic drive unit TC 110", standard	PT 0204 BN*
Operating instructions "Electronic drive unit TC 110 PB", Profibus	PT 0245 BN*
Operating instructions "Electronic drive unit TC 110 E74", acc. Semi E74	PT 0301 BN*
Operating instructions "Electronic drive unit TC 110 RS", RS-485	PT 0351 BN*
Declaration of conformity	Part of this document

*also available via www.pfeiffer-vacuum.com

1.2 Conventions

1.2.1 Safety instructions

The safety instructions in Pfeiffer Vacuum operating instructions are the result of risk evaluations and hazard analyses and are oriented on international certification standards as specified by UL, CSA, ANSI Z-535, SEMI S1, ISO 3864 and DIN 4844. In this document, the following hazard levels and information are considered:

DANGER
Imminent danger Indicates an imminent hazardous situation that will result in death or serious injury.
WARNING
Possibly imminent danger Indicates an imminent hazardous situation that can result in death or serious injury.
CAUTION
Possibly imminent danger Indicates an imminent hazardous situation that can result in minor or moderate injury.
NOTICE
Command or note Command to perform an action or information about properties, the disregarding of which may result in damage to the product.

1.2.2 Pictographs



Prohibition of an action to avoid any risk of accidents, the disregarding of which may result in serious accidents



Warning of a displayed source of danger in connection with operation of the unit or equipment



Command to perform an action or task associated with a source of danger, the disregarding of which may result in serious accidents



Important information about the product or this document

1.2.3 Instructions in the text

→ Work instruction: here you have to do something.

1.2.4 Abbreviations

DCU:	Display Control Unit
HPU:	Handheld Programming Unit
TC:	Electronic drive unit for turbopump
TPS:	Mains pack

1.2.5 Symbols used

The following symbols are used consistently throughout the diagrams:

- ⊕ High vacuum flange
- ⊖ Fore-vacuum flange
- ⊙ Vacuum flange of the backing pump
- ⊙ Exhaust flange of the backing pump
- ⚡ Electrical connection
- ⊙ Sealing gas connection
- ⊙ Venting connection
- ⊙ Cooling water connection

2 Safety

2.1 Safety precautions



Duty to inform

Each person involved in the installation, operation or maintenance of the vacuum pump must read and observe the safety-related parts of these operating instructions.

→ The operator is obligated to make operating personnel aware of dangers originating from the vacuum pump, the pumped medium and the entire system.



Installation and operation of accessories

Pfeiffer Vacuum pumps can be equipped with a series of adapted accessories. The installation, operation and maintenance of connected devices are described in detail in the operating instructions of the individual components.

→ For information on order numbers of components, see "Accessories".

→ Use original accessory parts only.



NOTICE

Checking the safety system against excess rotation speed

To provide the functioning of the integrated safety system for avoiding excess rotation speed, the pump must run-up from the standstill at least once a year.

→ Switch off the pump and await the complete standstill (rotation speed = 0 Hz).

→ Run-up the pump according to this operating instructions.



WARNING

Danger of unsafe electrical installation

Safe operation after installation is the responsibility of the operator.

→ Do not independently modify or change the pump and electrical equipment.

→ Make sure that the system is integrated in an emergency off safety circuit.

→ Consult Pfeiffer Vacuum for special requirements.



WARNING

Danger due to lack of power disconnection device

Pump and electronic drive unit are not equipped with a power disconnection device. Installation of a user-supplied power disconnection device in accordance with SEMI-S2.

→ Fit a circuit breaker with an interruption rating of min. 10,000 A.



WARNING

Danger of electric shock

In case of defect, the parts connected to the mains supply are under voltage.

→ Always keep the mains connection freely accessible so that you can disconnect it at any time.

- Do not expose any body parts to the vacuum.
- Observe all safety and accident prevention regulations.
- Regularly check the proper observance of all safety measures.
- **Power supply:** The turbopump power supply must apply to the requirements of double insulation between mains input voltage and operating voltage according to the regulations of IEC 61010 and IEC 60950. Therefore Pfeiffer Vacuum recommends to use exclusively original-power packs and -accessories. Only in this case Pfeiffer Vacuum is able to guarantee the compliance of the European and North American guidelines.
- A safe connection to the protective earthing conductor (PE) is recommended (protection class III).

- Do not loosen any plug connection during operations.
- Wait for the rotor to reach standstill before performing work on the high vacuum flange.
- Keep leads and cables well away from hot surfaces (> 70 °C).
- Never fill or operate turbopump with cleaning agent.
- Do not operate the turbopump with open high vacuum flange.
- Do not carry out any unauthorized modifications or conversions to the pump.
- When returning the turbopump observe the shipping instructions.

2.2 Protective equipment

Determined situations concerning the handling of vacuum pumps require wearing of personal protective equipment. The owner, respectively the employer are obligated to provide an adequate equipment to any operating persons.



DANGER

Danger to health by hazardous substances during maintenance or installation

Depending on the process vacuum pumps, components or operating fluids can be contaminated by toxic, reactive or radioactive substances.

→ Wear adequate protective equipment during maintenance and repairs or in case of reinstallation.



WARNING

Risk of injury through falling objects

When transporting vacuum pumps by hand, there is a danger through loads slipping and falling down.

→ Carry small and mid-size vacuum pumps two-handed.

→ Carry vacuum pumps > 20 kg by a suitable lifting device.

→ Wear safety shoes with steel toe cap according to directive EN 347.



CAUTION

Risk of injury through hot surfaces

Vacuum pumps can become hot during operation.

→ Allow the pump to cool before maintenance and repairs.

→ If necessary wear protective gloves according to EN 420.



CAUTION

Risk of injury through sharp edges

Rotor and stator disks of turbopumps have very sharp edges.

→ Before any working wait for the complete standstill of the pump.

→ Do not reach in the high vacuum flange.

→ If necessary wear protective gloves according to EN 420.

2.3 Proper use



NOTICE

EC conformity

The manufacturer's declaration of conformity becomes invalid if the operator modifies the original product or installs additional components.

→ Following installation into a plant and before commissioning, the operator must check the entire system for compliance with the valid EU directives and reassess it accordingly.

- The vacuum pump may only be used to generate a vacuum.
- Only operate the turbopump with an approved backing pump.

2.4 Improper use

Improper use will cause all claims for liability and warranties to be forfeited. Improper use is defined as usage for purposes deviating from those mentioned above, especially:

- transport, installation or operation of the pump in invalid orientation
- pumping of corrosive or explosive media
- pumping of condensing vapors
- pumping of liquids
- pumping of dusts
- operation with improper high gas throughput
- operation with improper high fore-vacuum pressures
- operation with improper high levels of insulated heat input
- operation in improper high magnetic fields
- operation with improper gas mode
- venting with improper high venting rates
- use of the vacuum pump to generate pressure
- operation of the devices in areas with ionizing radiation
- operation in potentially explosive areas
- use of the devices in systems in which impact-like stress and vibrations or periodic forces affect the devices
- use of accessories or spare parts, which are not named in this manual



Closure seal

The product is sealed at the factory. Damaging or removal of a closure seal leads to the loss of liability and warranty entitlements.

- Do not open the product within its warranty period!
- For process-related shorter maintenance intervals please contact the Pfeiffer Vacuum Service.

3 Transport and storage

3.1 Transport

- Reuse the transport container of the vacuum pump.
 - Transport or ship vacuum pumps in the original packing preferably.
- Only remove the protective covers from the high vacuum and the fore-vacuum side immediately before connection.
- Keep the original protective covers.
- Always transport the turbopump in its upright position.

3.2 Storage

- Close the flange openings by using the original protective covers.
- Close further connection ports by using the corresponding protective covers.
- Store the pump only indoors at temperatures between -25 °C and +55 °C.
- In rooms with moist or aggressive atmospheres, the pump must be airtight shrink-wrapped in a plastic bag together with a bag of desiccant.

4 Product description

4.1 Product identification

4.1.1 Pump types

The product designation consists of a family designation (1), the size (2), which is oriented on the pumping speed, and if applicable the additional properties (3) of the pump.

HiPace⁽¹⁾ 300⁽²⁾Plus⁽³⁾

1. Family designation	2. Model designation	3. Property designation
HiPace	300 = Model designation of the pump related to its pumping speed class	none = Standard version U = Upside-down installation orientation C = Corrosive gas version P = Process M = Active magnetic bearing T = Temperature management system E = High Efficiency H = High Compression I = Ion implantation

- The property designation "**Plus**" marks turbopumps with particularly low vibration run and low stray magnetic field.

4.1.2 Pump features



This product has been tested to the requirements of CAN/CSA-C22.2 No. 61010-1, second edition, including Amendment 1, or a later version of the same standard incorporating the same level of testing requirements.

For information about other certifications, if applicable, please see the signet on the product or:

- www.tuvdotcom.com
- TUVdotCOM-ID 0000021320

Characteristics	HiPace 300 Plus		
HV flange	DN 100 ISO-K	DN 100 ISO-F	DN 100 CF-F
Flange material	Aluminium	Aluminium	Stainless steel

To correctly identify the product when communicating with Pfeiffer Vacuum, always have the information from the rating plate available.

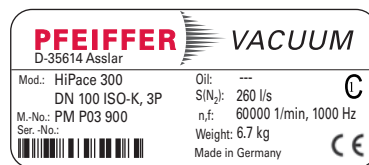

Fig. 1: Example for a rating plate

4.1.3 Scope of delivery

- HiPace 300 Plus with TC 110 and 24 V DC
- Protective cover for the high vacuum flange and the fore-vacuum flange
- Operating instructions

4.2 Function

The turbopump HiPace 300 Plus forms a complete unit together with the electronic drive unit TC 110. For the voltage supply only Pfeiffer Vacuum power supplies may be used (e.g. TPS or DCU).

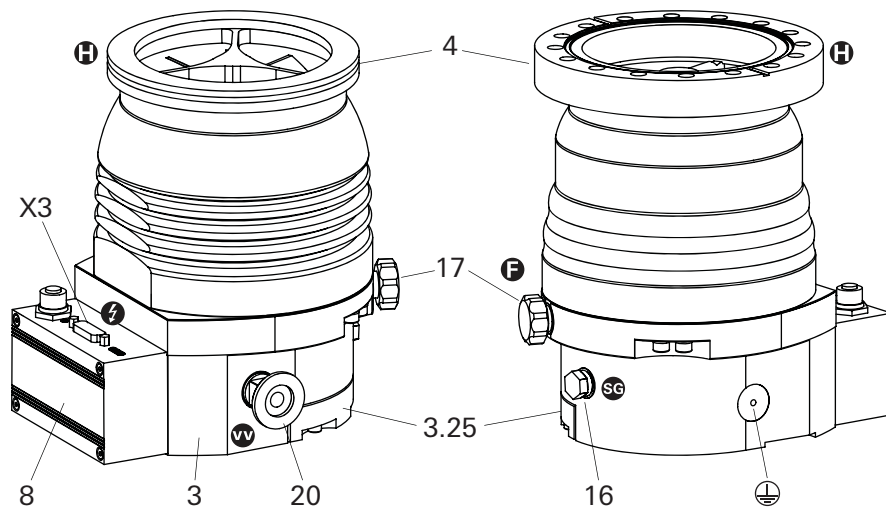

Fig. 2: View of HiPace 300 Plus with TC 110

3	Pump lower part	14	Cooling water connection	17	Venting connection
4	Pump casing	16	Sealing gas connection	20	Fore-vacuum connection
8	Electronic drive unit TC 110				

4.2.1 Cooling

- Convection cooling
- Air cooling (optional)
- Water cooling (optional)

In the case of excess temperature the electronic drive unit reduces the drive power automatically. Depending on the application and the HiPace different cooling variants are selectable.

4.2.2 Rotor bearing

Hybrid bearing TurboDrag pump

- High vacuum side: maintenance-free permanent magnetic bearing
- Fore-vacuum side: ceramic ball bearing

4.2.3 Drive

Electronic drive unit TC 110

4.3 Range of application

The pump HiPace 300 Plus must be installed and operated under the following ambient conditions:

Installation location	weather protected (indoors)
Protection category	IP 54
Protection class	III
Ambient temperature	+5 °C to +30 °C with convection cooling without gas throughput +5 °C to +35 °C with air cooling +5 °C to +40 °C with water cooling
Relative humidity	max. 80 %, at T ≤ 31 °C, up to max. 50 % at T ≤ 40 °C
Atmospheric pressure	750 hPa - 1060 hPa
Installation altitude	5000 m max.
Degree of pollution	2
Permissible surr. magnetic field	≤ 3 mT
Overvoltage category	II
Connection voltage TC 110	24 V DC



Remarks to ambient conditions

The specified permissible ambient temperatures apply to operation of the turbopump at maximum permissible fore-vacuum pressure or at maximum gas throughput depending on the cooling method. The turbopump is intrinsically safe by a redundant temperature monitoring.

- By reducing the fore-vacuum pressure or gas throughput, the turbopump can be operated at higher ambient temperatures.
- If the maximum permissible operating temperature of the turbopump is exceeded, the electronic drive unit reduces drive power first and switches off then, if necessary.

5 Installation



WARNING

Danger to life by the turbopump ripping off in case of malfunctions

Rapid shutdown of the rotor generates destructive torques in case of burst up to 2000 Nm according to ISO 27892. If it is **not** properly fixed, the turbopump rips off. The energy released thereby can throw the entire pump or pieces from its interior through the room. There is a danger of severest, possibly fatal, injuries as well as serious property damage.

- Carefully follow the installation instructions in this handbook.
- Only use approved original parts from Pfeiffer Vacuum (Accessories) for the installation.



Installation and operation of accessories

Pfeiffer Vacuum pumps can be equipped with a series of adapted accessories. The installation, operation and maintenance of connected devices are described in detail in the operating instructions of the individual components.

- For information on order numbers of components, see "Accessories".
- Use original accessory parts only.

5.1 Preparatory work

When installing the pump, observe the following conditions:

- the ambient conditions specified for the range of application
 - When using a casing heating and a water cooling unit the temperature of the connected flange of the vacuum chamber must not exceed 120 °C.
 - The pump may be fastened to the floor only after consultation with Pfeiffer Vacuum.
 - It is not allowed to operate the device in systems where impact-like stresses and vibrations or periodically forces occur.
- Ensure sufficient cooling for the turbopump.
- Where magnetic fields > 3 mT are involved, a suitable shielding must be used. Check installation location and consult Pfeiffer Vacuum if needed!
- The maximum permissible rotor temperature for the turbopump is 90 °C. If high temperatures arise for process reasons, the radiated heat input must not exceed 3 W. Install suitable screening sheets, if necessary (design information on request).

5.2 Set-up

- Ensure the greatest possible cleanliness when installing any high vacuum parts. Unclean components prolong the pump-down time.
- All flange components must be grease-free, dust-free and dry at installation.
- The operating fluid reservoir is already installed and filled for the turbopump HiPace 300 Plus.

5.2.1 Earthquake safety

An earthquake can result in contact with the safety bearings. All forces occurring hereby are safely absorbed by the properly installed flange connections.

→ Secure the vacuum chamber against shifting and tipping on customers side.

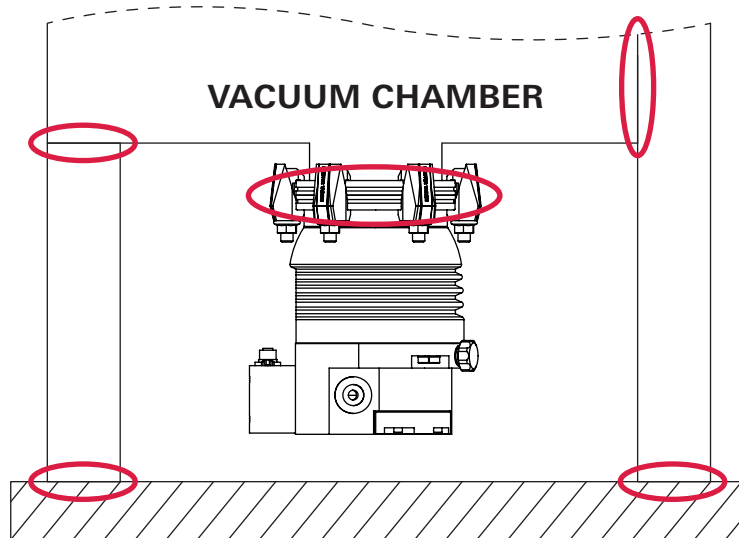



Fig. 3: Example: How to secure against shifting and tipping by external tremors

 = Safety connection, implementation each by the customer

5.2.2 Use of a splinter shield or protection screen

Pfeiffer Vacuum centering rings with splinter shield or protection screen in the high vacuum flange protect the turbopump against foreign bodies coming from the chamber. Thus, the pumping speed of the pump is reduced.

	Reduced pumping speed in %			
	H ₂	He	N ₂	Ar
Splinter shield DN 100	5	7	24	24
Protection screen DN 100	2	2	10	8

5.2.3 Vibration damper



WARNING

Danger from the turbopump and vibration damper being torn-off

In case of sudden blocking of the rotor, an applied vibration damper cannot compensate any of the occurring forces. There is a danger of the turbopump being torn-off and thereby resulting severest injuries and property damages. Applicable safeguards must be taken to compensate possible occurring torques.

→ Definitely consult with Pfeiffer Vacuum.

→ Do not exceed the max. permissible temperature at the vibration damper (100 °C).

5.3 Mounting orientation



NOTICE

Damage to the pump through wrong installation orientation

The turbopump HiPace 300 Plus is to install with the high vacuum flange upwards only. Other installation orientations are not specified and can damage the pump or lead to faulty processes.

- Mount the pump with vertical rotor axis and the high vacuum flange upwards only.
- Never operate the pump upside-down with the high vacuum flange downwards.

→ Support pipes in front of the vacuum pump or remove them. No force from the pipe system may be exerted on the fixed pump.

The maximum axial loading capacity of the high vacuum flange is 200 N (equals 20 kg). A one-sided load on the high vacuum flange is not permitted.

5.4 Connecting the high vacuum side

If the rotor is suddenly blocked, the torques arising from the system and the high vacuum flange must be absorbed. Only the components listed in the following can be used to fasten the turbopumps to the high vacuum flange. The installation elements for turbopumps are special designs by Pfeiffer Vacuum. In all operating conditions, the tensile strength of the flange material must be at least 170 N/mm².

→ Secure the vacuum chamber against shifting and tipping on customers side.



DANGER

Danger to life - impermissible fastening

Twisting or tearing-off is possible in case the rotor is suddenly blocked due to the fastening of pumps on a vacuum chamber with different flange variants.

→ Use only the correct mounting kit from Pfeiffer Vacuum.

→ Pfeiffer Vacuum will not accept any liability for all damages resulting from impermissible fastening.



NOTICE

Observe shape tolerances for the counter flange

Unevennesses of the customer supplied counter flange can lead to warping of the pump casing despite proper fastening. Leakiness and negative running characteristics can be the result.

→ Do not exceed an evenness of max. 0.05 mm for the whole surface.



Mounting of ISO flanges

If the rotor suddenly blocks the connection of high vacuum flanges of types ISO-KF or ISO-K can lead to twisting despite proper installation.

- The tightness of the high vacuum flange is not at risk thereby.

5.4.1 Installation of ISO-K flange with ISO-K flange

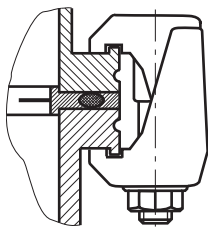

For the installation the following components are exclusively authorized:

- the valid mounting kit of the Pfeiffer Vacuum accessories programme
- mounting materials including protection screen or splinter shield are optionally available

→ Mind that the sealing surfaces are not damaged.

- 1) Connect the flanges according to the drawing and with the component parts of the mounting kit.
- 2) Use the required number of **6** claw clamps.
- 3) Tighten the claw clamps crosswise in three steps.
- 4) Tightening torque: 5, 15, 25 ±2 Nm

5.4.2 Installation of ISO-K flange with ISO-F flange

The connection types for installation of ISO-K to ISO-F flange are "hex screw and threaded hole," "stud screw and threaded hole," and "stud screw and through hole".

For the installation the following components are exclusively authorized:

- the valid mounting kit of the Pfeiffer Vacuum accessories programme
- mounting materials including protection screen or splinter shield are optionally available

Hexagon screw and threaded hole

→ Mind that the sealing surfaces are not damaged.

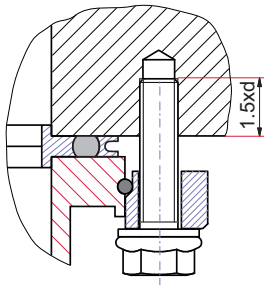

- 1) Put the collar flange over the high vacuum flange of the turbopump.
- 2) Insert the retaining ring into the groove of the high vacuum flange.
- 3) Fasten the turbo pump with collar flange and centering ring to the counter flange as shown in the graphic.
- 4) Use the required number of **8** hex screws with washer.
- 5) Screw hex screws $1.5 \times d$ into the threaded holes.
 - The tensile strength of the flange material must be at least 270 N/mm^2 in all operating conditions.
- 6) Tighten the hex screws crosswise in three steps.
- 7) Tightening torque DN 100: $5, 10, 16 \pm 1 \text{ Nm}$

Stud screw and threaded hole

→ Mind that the sealing surfaces are not damaged.

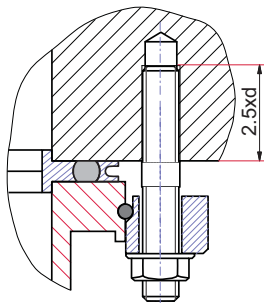

- 1) Use the required number of **8** stud screws and nuts.
- 2) Screw in the stud screws with the shorter threaded end $2.5 \times d$ in the bore holes on the counter flange.
- 3) Put the collar flange over the high vacuum flange of the turbopump.
- 4) Insert the retaining ring into the groove of the high vacuum flange.
- 5) Fasten the turbo pump with collar flange and centering ring to the counter flange as shown in the graphic.
- 6) Tighten the nuts crosswise in three steps.
- 7) Tightening torque DN 100: $5, 10, 16 \pm 1 \text{ Nm}$

Stud screw and through hole

→ Mind that the sealing surfaces are not damaged.

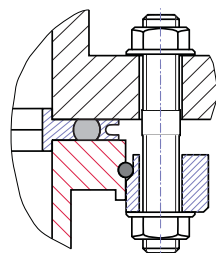

- 1) Put the collar flange over the high vacuum flange of the turbopump.
- 2) Insert the retaining ring into the groove of the high vacuum flange.
- 3) Fasten the turbo pump with collar flange and centering ring to the counter flange as shown in the graphic.
- 4) Use the required number of **8** stud screws and nuts.
- 5) Tighten the nuts crosswise in three steps.
- 6) Tightening torque DN 100: $5, 10, 16 \pm 1 \text{ Nm}$

5.4.3 Installation of ISO-F with ISO-F flange

The connection types for installation of ISO-F to ISO-F flange are "hex screw and threaded hole," "stud screw and threaded hole," and "stud screw and through hole".

For the installation the following components are exclusively authorized:

- the valid mounting kit of the Pfeiffer Vacuum accessories programme
- mounting materials including protection screen or splinter shield are optionally available

Hexagon screw and threaded hole

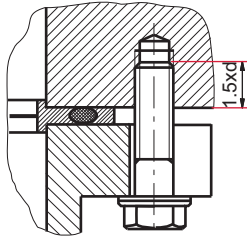

→ Mind that the sealing surfaces are not damaged.

- 1) Connect the flanges according to the drawing and with the component parts of the mounting kit.
- 2) Use the required number of **8** hex screws with washer.
- 3) Screw hex screws $1.5 \times d$ into the threaded holes.
 - The tensile strength of the flange material must be at least 270 N/mm^2 in all operating conditions.
- 4) Tighten the hex screws crosswise in three steps.
- 5) Tightening torque DN 100: $10, 20, 38 \pm 3 \text{ Nm}$

Stud screw and threaded hole

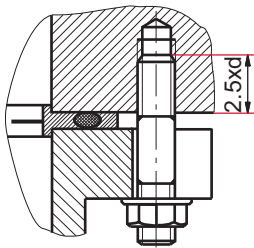

→ Mind that the sealing surfaces are not damaged.

- 1) Use the required number of **8** stud screws and nuts.
- 2) Screw in the stud screws with the shorter threaded end $2.5 \times d$ in the bore holes on the counter flange.
- 3) Connect the flanges according to the drawing and with the component parts of the mounting kit.
- 4) Tighten the nuts crosswise in three steps.
- 5) Tightening torque DN 100: $10, 20, 38 \pm 3 \text{ Nm}$

Stud screw and through hole

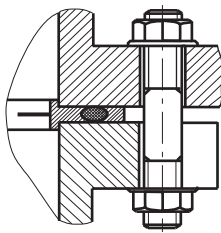

→ Mind that the sealing surfaces are not damaged.

- 1) Connect the flanges according to the drawing and with the component parts of the mounting kit.
- 2) Use the required number of **8** stud screws and nuts.
- 3) Tighten the nuts crosswise in three steps.
- 4) Tightening torque DN 100: $10, 20, 38 \pm 3 \text{ Nm}$

5.4.4 Installation of CF- flanges



NOTICE

Assembly of CF flanges!

Loss of sealing capability due to a lack of cleanliness when handling the sealing and CF flange.

- Assemble the sealing dry and oil-free.
- Always wear gloves when handling the components.
- Do not damage the surfaces and cutting edges.

The connection types for installation of CF to CF flange are "hexagon screw and through hole", "stud screw and threaded hole" as well as "stud screw and through hole".

- the valid mounting kit of the Pfeiffer Vacuum accessories programme
- A copper seal
- protection screen or splinter shield are optionally

Hexagon screw and through hole

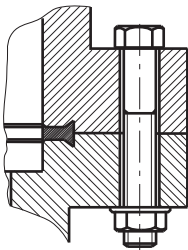

- 1) If used: Insert protective screen or splinter shield with the clamping lugs downward into the high vacuum flange of the turbopump.
- 2) Place the seal exactly in the hollow.
- 3) Connect the flanges using **16** hexagon-head screws (M8) with washers and bolts.
- 4) Tighten the screw connections circularly.
- 5) Tightening torque: 22 ± 2 Nm
- 6) After this, check the torque, since flowing of the sealing material may make it necessary to tighten the screws again.

Stud screw and threaded hole

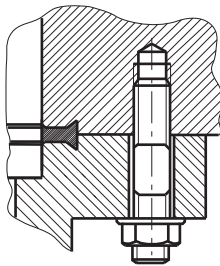

- 1) Screw in the stud screws (**16** pieces, M8) with the shorter threaded end into the threaded holes of the counter flange.
- 2) If used: Insert protective screen or splinter shield with the clamping lugs downward into the high vacuum flange of the turbopump.
- 3) Place the seal exactly in the hollow.
- 4) Connect the flanges using washers and nuts.
- 5) Tighten the screw connections circularly.
- 6) Tightening torque: 22 ± 2 Nm
- 7) After this, check the torque, since flowing of the sealing material may make it necessary to tighten the screws again.

Stud screw and through hole

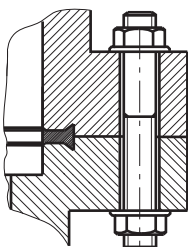

- 1) If used: Insert protective screen or splinter shield with the clamping lugs downward into the high vacuum flange of the turbopump.
- 2) Place the seal exactly in the hollow.
- 3) Connect the flanges using **16** hexagon-head screws (M8) with washers and bolts.
- 4) Tighten the screw connections circularly.
- 5) Tightening torque: 22 ± 2 Nm
- 6) After this, check the torque, since flowing of the sealing material may make it necessary to tighten the screws again.

5.5 Connecting the fore-vacuum side

Recommendation: As backing pump, use a suitable vacuum pump from the Pfeiffer Vacuum programme.



WARNING

Damage to health due to poisonous gases

Process gases can damage health and contaminate the environment.

- Safely lead away the gas emission from the backing pump!
- Observe all safety recommendations of the gas producer.

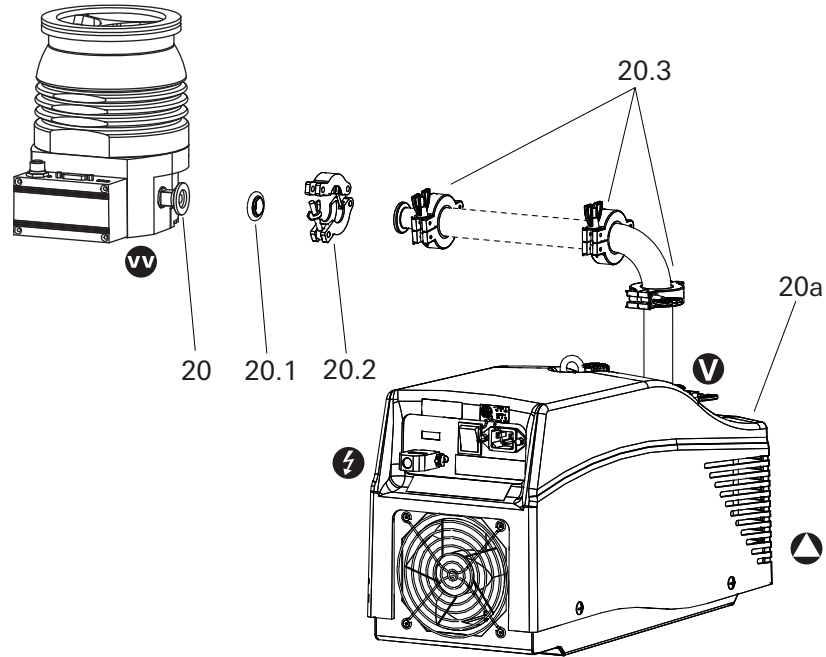

Fig. 4: Connecting the backing pump

20	Fore-vacuum connection	20.1	Centering ring	20.3	Vacuum components
20a	Backing pump	20.2	Clamping ring		



NOTICE

Design of the fore-vacuum connection regarding sudden twisting of the pump

If the rotor suddenly blocks the connection of high vacuum flanges of types ISO-KF or ISO-K can lead to twisting despite proper installation.

- Keep masses small, which can be installed directly to the pump.
- Connect flexible line elements directly to the turbopump, if necessary.
- With rigid pipe connections: Install bellows for attenuation of vibrations in the connection line.
- Connect the fore-vacuum line with small-flange components or threaded hose couplings. Do not narrow the free cross section of the fore-vacuum flange!
- The backing pump is connected electrically via a relay box.
- For connection and operation of the backing pump see its operating instructions.



Backing pump control

Backing pump control via electronic drive unit of the turbopump is possible using a relay box or respective connection cables of the accessory programme.

- Refer to the operating instructions of the respective accessory.

5.6 Connections to the turbopump

5.6.1 Electronic drive unit

Turbopumps with integrated electronic drive unit are designed for various applications. Therefore different connection panels are available.

- TC 110 in standard version
- TC 110 PB for Profibus linking
- TC 110 E74 in dependence on specification SEMI E74
- TC 110 RS with interface RS-485

Detailed description for function, configuration and operation with the respective connection panel are given in the specific operating instructions for the electronic drive unit.

5.6.2 Earthing

Pfeiffer Vacuum recommends to connect an appropriate earthing wire to derive applicative interferences.

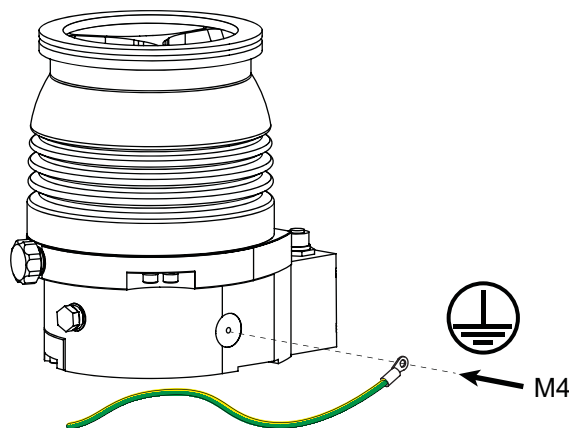

Fig. 5: Installing the earthing connection

5.6.3 Power and electrical supply

For voltage supply of the electronic drive unit TC 110, only use original power supplies (e.g. TPS 110 or DCU 110). Use of other power supplies only after consultation with Pfeiffer Vacuum. Connecting cables are available from the Pfeiffer Vacuum accessories.

Connecting cable	Function
TC 110 - TPS/DCU 110/180 with bridges, RS-485	<ul style="list-style-type: none"> • Voltage supply via power supply pack • Automatic start by bridges on pins 2, 5, 7 • Connection to a display and control unit via RS-485
TC 110 - TPS/DCU 110/180 with accessory ports, RS-485	<ul style="list-style-type: none"> • Voltage supply via power supply pack • Accessory connection via M8 plugs • Connection to a display and control unit via RS-485
TC 110 - TPS 110/180 with bridges	<ul style="list-style-type: none"> • Voltage supply via power supply pack • Automatic start by bridges on pins 2, 5, 7
TC 110 - TPS 110/180 with bridges, with accessory ports	<ul style="list-style-type: none"> • Voltage supply via power supply pack • Automatic start by bridges on pins 2, 5, 7 • Accessory connection via M8 plugs



WARNING

Danger of electric shock

In case of defect, the parts connected to the mains supply are under voltage.

→ Always keep the mains connection freely accessible so that you can disconnect it at any time.

→ Make sure that the voltage of the turbopump is valid.

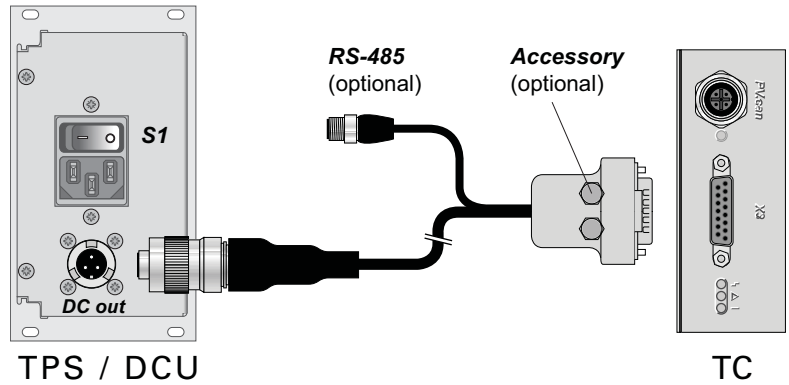

Fig. 6: Connecting the TC 110 to a power supply using a Pfeiffer Vacuum connecting cable

- Switch off switch **S1** on the power pack (position "0").
- Place and fix the connecting cable with the 15-pole mating plug into the connection "X3" on the electronic drive unit.
- Insert the connection cable with the plug in the connection "DC out" on the power supply and close the bayonet lock.

When using a Pfeiffer Vacuum display and control unit:

- Connect the display and control unit to the plug "RS485" of the adapter or the connecting cable.

5.7 Accessory connection

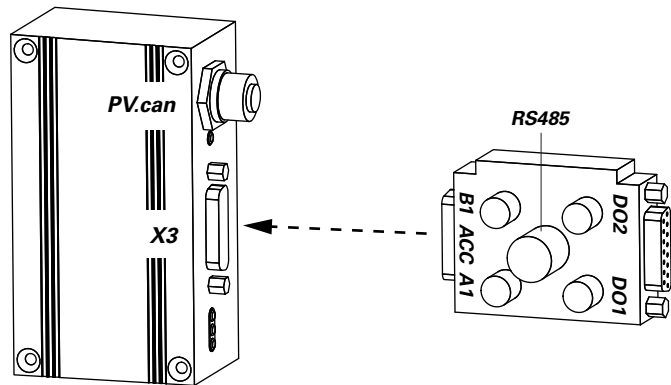

Fig. 7: Example: Connections on the electronic drive unit TC 110 with adapter TCS 12



Accessory connection on the TC 110

The connection of Pfeiffer Vacuum accessory units to the electronic drive unit TC 110 is only possible by using respective connecting cables or adapters.

- Configure the preferred accessory output via RS-485 using a Pfeiffer Vacuum display and control unit or a PC.
- Consider the operating instructions "Electronic Drive Unit TC 110".



Accessory connection to an electronic drive unit in special design

Differing to the standard model, drive units in special design (e.g. Profibus panel) can be equipped with accessory connections.

- Refer to the operating instructions of the respective electronic drive unit.
- Connect the control lead of the accessory directly to the electronic drive unit.
- Configure the preferred accessory output via RS-485 using a Pfeiffer Vacuum display and control unit or a PC.

5.7.1 Air cooling

Turbopumps with the electronic drive unit TC 110 (24 V DC) may be operated with air cooling up to an ambient temperature of +35 °C.

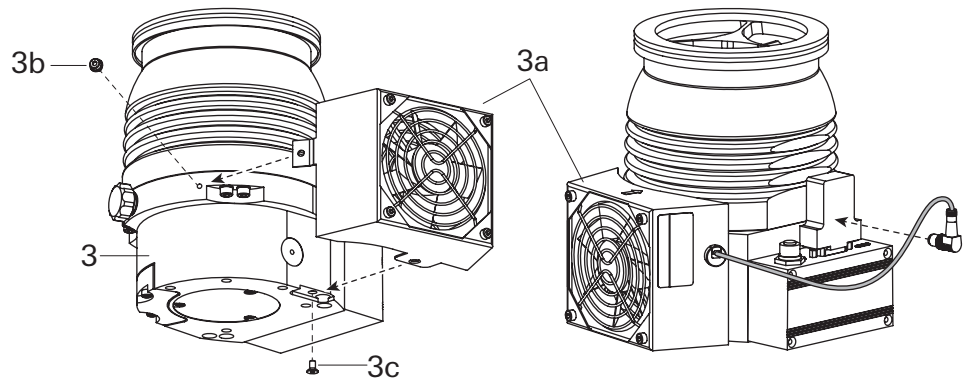

Fig. 8: Connecting the air cooling

3	Pump lower part	3b	Allen head screw
3a	Air cooling unit	3c	Counter-sunk screw

- Fix the air cooling unit to the holes of the turbopump using two screws.
- Plug in and fix the accessory's control lead to a free connection port on the connecting cable or adapter of the electronic drive unit.
- Make the settings and control via the interfaces of the electronic drive unit.

5.7.2 Venting valve

The Pfeiffer Vacuum venting valve is used for automatic venting in case of shut-down or power failure.

The permissible connection pressure is max. 1500 hPa absolute.

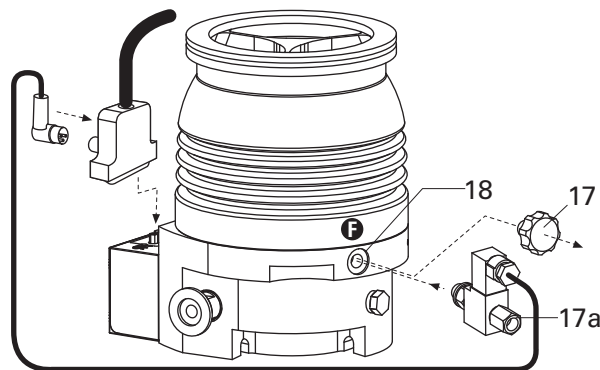

Fig. 9: Connecting the venting valve

18	Seal ring	17	Venting screw	17a	Venting valve
----	-----------	----	---------------	-----	---------------

- Unscrew the venting screw with seal ring from the venting connection.
- Screw in the venting valve with seal ring.
- Plug in and fix the accessory's control lead to a free connection port on the connecting cable or adapter of the electronic drive unit.
- Make the settings and control via the interfaces of the electronic drive unit.
- If necessary install a venting gas supply (e.g. inert gas) to the intake (G 1/8") of the solenoid valve.

5.7.3 Heating jacket

The turbopump and vacuum chamber can be heated to reach the ultimate pressure more quickly. Use of a heating jacket is only permissible for pumps with the high vacuum flange in stainless steel design. The heating duration depends on the degree of contamination as well as the ultimate pressure to be reached and should be at least 4 hours.



NOTICE

Dangerous excess temperatures
 Process-related high temperatures can result in impermissible excess temperatures and thus damage to the turbopump.

- Water cooling must be used when employing a casing heating or during operation with heated vacuum chambers.
- Do not introduce any additional energy into the pump.



CAUTION

Risk of burns
 High temperatures arise when the turbopump or vacuum chamber are baked out. As a result, there is a danger of burns from touching hot parts, even after the casing heating is switched off!

- Thermally insulate heating jacket, pump housing and vacuum chamber, if possible during installation.
- Do not touch heating jacket, pump casing and vacuum chamber during bake out.

- When using a casing heating and a water cooling unit the temperature of the connected flange of the vacuum chamber must not exceed 120 °C.
- The maximum permissible rotor temperature for the turbopump is 90 °C. If high temperatures arise for process reasons, the radiated heat input must not exceed 3 W. Install suitable screening sheets, if necessary (design information on request).

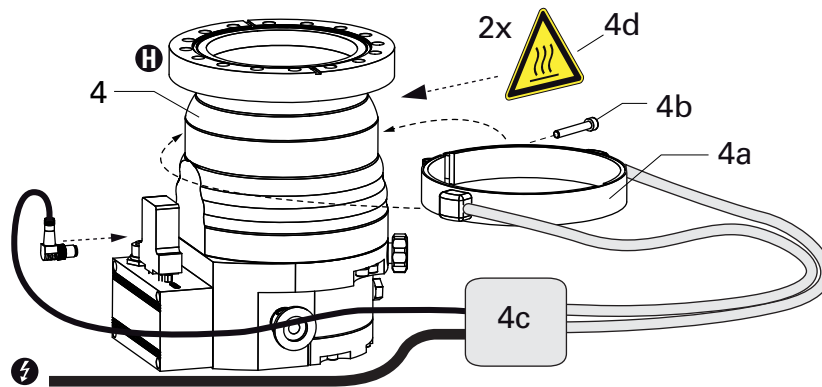

Fig. 10: Connecting the heating jacket

- | | | | | | |
|----|----------------|----|-------------------|----|-----------------|
| 4 | Pump casing | 4b | Fixing screw | 4d | Warning sticker |
| 4a | Heating jacket | 4c | Heating relay box | | |

- Bend open the outer heating jacket on the tensioning strap and place it sideways on to the cylindrical segment of the pump casing.
 - Do not bend the heating straps!
 - The heating jacket must seat completely on the casing segment.
- Fix the heating jacket with the fixing screw on the casing.
 - Observe the tightening torque for the fixing screw!

Fixing screw	Tightening torque in cold condition	Tightening torque during the heating-up	Singular retightening after the cooling down
M5	6 Nm	7 Nm	7 Nm
M6	11 Nm	12 Nm	12 Nm

Table 1: Tightening torques for fixing screws of heating jackets

- Plug in and fix the accessory's control lead to a free connection port on the connecting cable or adapter of the electronic drive unit.
- Make the settings and control via the interfaces of the electronic drive unit.
- Establish the mains supply for the relay box according to the accessory operating instructions.

5.7.4 Sealing gas connection

The turbopump must be operated with sealing gas to protect it, such as in the case of unclean processes or high gas throughput. The supply is made via a sealing gas valve or alternatively via a sealing gas throttle without control. The activation of the control valve for the sealing gas connection is not pre-installed in the electronic drive unit and has to be configured via their interfaces.

The permissible connection pressure is max. 1500 hPa absolute.

- When operating the pump with more than 50 % of the maximum gas throughput, sealing gas must be used to ensure rotor cooling.
- The sealing gas flow rate amounts 12.5 - 15.0 sccm for the HiPace 300 Plus.

Sealing gas supply with control valve

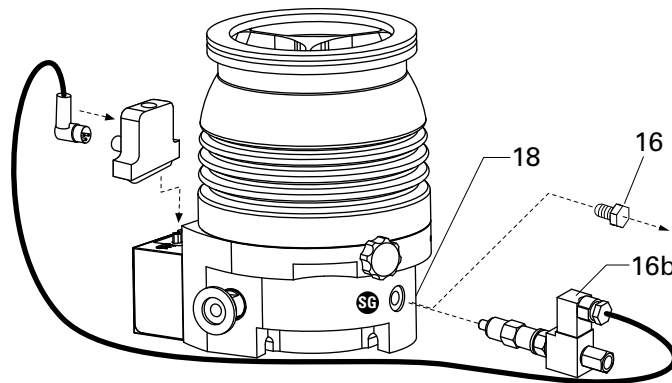

Fig. 11: Connecting the sealing gas valve

18 Seal ring 16 Locking screw 16a Sealing gas valve

- Unscrew the locking screw with seal ring out of the sealing gas connection.
- Screw the sealing gas valve with seal ring into the sealing gas connection.
- Plug in and fix the accessory's control lead to a free connection port on the connecting cable or adapter of the electronic drive unit.
- Make the settings and control via the interfaces of the electronic drive unit.
- Install the sealing gas supply (e.g. inert gas) via a connection adapter or on the inlet side (G 1/8") of the control valve.

Sealing gas supply without control valve

- Unscrew the locking screw with seal ring out of the sealing gas connection.
- Screw the sealing gas throttle with sealing ring into the sealing gas connection.

5.7.5 Water cooling

As an option turbopumps HiPace 300 Plus with TC 110 can be equipped with water cooling.

- In case of increased backing pressure (> 0.1 hPa) and/or operation with high gas throughputs, either air or water cooling may be used.
- Generally use water cooling if the ambient temperature is > +35 °C.

Cooling water connection	Swiveling screw-fitting with plug and socket connection
Hose lines	External diameter 8 mm Internal diameter 6 mm

Parameter	Cooling water
Appearance	filtrated, mechanically clear, optically clear, no turbidity, no sediments, free of grease and oil
pH value	7 to 9
Carbonate hardness max.	10 °dH 12.53 °e 17.8 °fH 178 ppm CaCO ₃
Chloride content max.	100 mg/l
Sulphate content max.	240 mg/l
Carbon dioxide content max.	undetectable
Ammonia content max.	undetectable
Electrical conductivity max.	500 µS/cm
Particle size max.	150 µm
Cooling water temperature	refer to "Technical Data"
Cooling water consumption	refer to "Technical Data"
Fore-line overpressure max.	6000 hPa

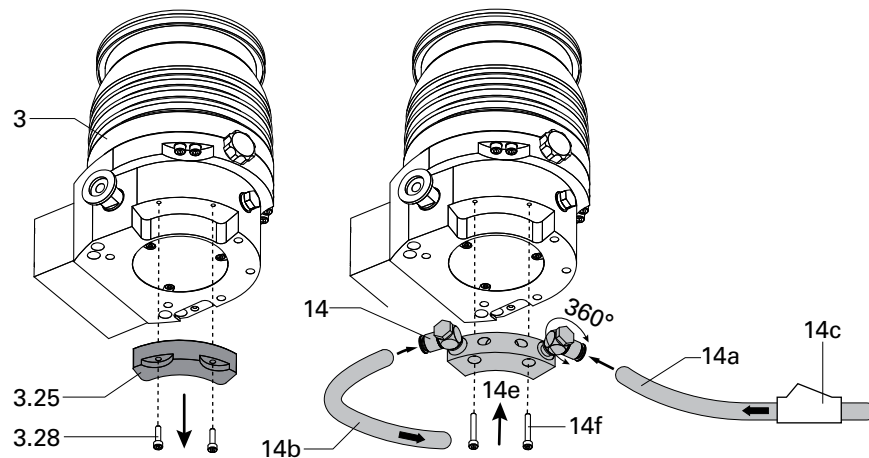

Fig. 12: Connecting the cooling water

- | | | |
|-----------------------|----------------------------|------------------------|
| 3 Pump lower part | 14 Swiveling screw-fitting | 14c Dirt trap |
| 3.25 Plastic cover | 14a Fore-line | 14e Water cooling unit |
| 3.28 Allen head screw | 14b Return line | 14f Allen head screw |

- ➔ Unscrew and remove the plastic cover with allen head screws from the pump lower part.
- ➔ Insert the water cooling unit from the bottom into the clearance of the pump lower part and fix it with the supplied mounting material.
 - Torque: **2.5 Nm**.
- ➔ Insert hoses for the water cooling fore- and return-line as far as they will go in one cooling water connection each.
- ➔ **Recommendation:** install dirt trap in the fore-line.
- ➔ Torque of the banjo fitting: **3-3.5 Nm**.

6 Operation

6.1 Commissioning

The following important settings are programmed in the electronic drive unit ex factory.

- Parameter **[P:027]** Gas mode: 0 = heavy gases
- Parameter **[P:700]** Set value max. run-up time monitoring: 8 min
- Parameter **[P:701]** Rotation speed switchpoint: 80% of the nominal rotation speed
- Parameter **[P:707]** Set value in rotation speed setting mode: 65 % of the nominal rotation speed
- Parameter **[P:708]** Set value power consumption: 100%
- Parameter **[P:720]** Venting rotation speed at delayed venting: 50 % of the nominal rotation speed
- Parameter **[P:721]** Venting time: 3600 s

- When water cooling is used: Open cooling water supply and check the flow.
- When sealing gas is used: Open the sealing gas supply and check the flow.
- Establish the mains for the power supply.



NOTICE

Risk of destroying the pump by inputting too much energy

Simultaneous loading by means of high drive power (gas flow rate, fore-vacuum pressure), high heat radiation, or strong magnetic fields results in uncontrolled heating of the rotor and may destroy the pump.

- Reduced limit values apply when combining these loads.
- If necessary consult with Pfeiffer Vacuum.



NOTICE

Danger of the pump being destroyed

Pumping of gases with a higher molecular mass in the wrong gas mode can lead to destruction of the pump.

- Ensure the gas mode is correctly set.
- Contact Pfeiffer Vacuum before using gases with a greater molecular mass (> 80).

6.2 Operation modes

The following operation modes are available:

- Operation without operating unit
- Operation via "X3" connection
- Operation via RS-485 and Pfeiffer Vacuum display and control units or PC
- Operation via field bus

6.3 Function description



WARNING

Danger due to open high vacuum flange

The rotor of the turbopump turns at high speed. If the high vacuum flange is open, there is a danger of cut injuries and that the pump can be destroyed by objects falling into it.

- Never operate the pump with an open high vacuum flange.

6.3.1 Operation without operating unit



CAUTION

Automatic start

After bridging the contacts Pin 2, 5, 7 on the connection "X3" or using a connecting cable "with bridges" **and** setting up the supply voltage, the turbopump will run up immediately.

→ Switch on the mains supply on the turbopump immediately before operation.

→ For operation without the control unit, the respective connecting cable "with bridges" must be in the "X3" connection on the TC 110.

→ Switch on the supply voltage with switch S1 on the power supply.

After operating voltage is applied, the TC 110 performs a self-test to check the supply voltage. Once the self-test has been successfully completed on the TC 110, the turbopump and the backing pump - if connected - begin to operate.

6.3.2 Operation via "X3" connection

Remote control is possible via the 15-pin D-sub connector labelled "X3" on the electronic drive unit. The accessible individual functions are mapped to "PLC levels".

→ Consider the following manuals for the operation via remote control:

- Operating instructions "Electronic drive unit TC 110"

6.3.3 Operation with DCU or HPU

→ Consider the following manuals for the operation via Pfeiffer Vacuum display and control units:

- Operating instructions "DCU"
- Operating instructions "HPU"
- Operating instructions "Electronic drive unit TC 110"

→ Connect the display and control unit to the plug "RS485" of the adapter or the connecting cable.

→ Switch on the supply voltage with switch S1 on the power supply or on the DCU 110.

→ Settings are possible via interface RS-485 by using DCU, HPU or PC.

6.3.4 Operation via fieldbus

Integrating and operating Pfeiffer Vacuum turbopumps in the customer's field bus system is possible for electronic drive units with a corresponding field bus panel.

→ Consider the following manuals for the operation via field bus:

- Operating instructions for the electronic drive unit with the respective connection panel

6.4 Monitoring of the operation conditions

6.4.1 Temperature monitoring

The drive power is reduced in case of impermissible motor temperature or impermissibly high housing temperature. This can cause falling below the rotation speed switchpoint and so result in turning off the turbopump.

6.4.2 Operation display via LED

LEDs in the front panel of the electronic drive unit show basic operating conditions of the turbopump. A differentiated malfunction and warning display is possible only for operation with DCU or HPU.









LED	Symbol	LED status	Display	Meaning
Green 		Off	—	currentless
		On, flashing		"Pumping Station OFF", rotation speed $\leq 60 \text{ min}^{-1}$
		On, invers flashing		"Pumping Station ON", set rotation speed not attained
		On, constantly		"Pumping Station ON", set rotation speed attained
		On, blinking		"Pumping Station OFF", rotation speed $> 60 \text{ min}^{-1}$
Yellow 	△	Off	—	no warning
		On, constantly		Warning
Red 	⚡	Off	—	no malfunction
		On, constantly		Malfunction

Fig. 13: Behaviour and meaning of LEDs on the electronic drive unit

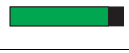
6.5 Switching off and venting

6.5.1 Switching off

After the turbopump is switched off, it must be vented to avoid contamination due to particles streaming back from the fore-vacuum area.

- Close the fore-vacuum: Switch off the backing pump or close a fore-vacuum valve.
- Switch off the turbopump on the control unit or via remote control.
- Venting (possibilities see below)
- For water cooling: Shut off the water supply.

6.5.2 Venting

Manually venting

- Open the venting screw (included) in the venting connection of the turbopump about one turn.

Venting with Pfeiffer Vacuum Venting Valve

- Enable venting via the functions of the electronic drive unit.
- Settings are possible via interface RS-485 by using DCU, HPU or PC.

Venting rotation speed	Switch off the pumping station	Mains power failure ¹⁾
50 % of the nominal rotation speed	Venting valve opens for 3600 s (1 h, works setting)	Venting valve opens for 3600 s (1 h, works setting)

¹⁾When mains power is restored the venting procedure is aborted.

Basic information for the rapid venting

Venting of the vacuum chamber in two steps. Ask for details on individual solutions from Pfeiffer Vacuum.

- Vent for 20 seconds at a rate of pressure rise of max. 15 hPa/s.
 - The valve cross section for the venting rate of 15 hPa/s must be adapted to the size of the vacuum chamber.
 - For small vacuum chambers, use the Pfeiffer Vacuum venting valve.
- Then vent with an additional venting valve of any desired size.

7 Maintenance / replacement



WARNING

Contamination of parts and operating fluid by pumped media is possible.

Poisoning hazard through contact with materials that damage health.

- In the case of contamination, carry out appropriate safety precautions in order to prevent danger to health through dangerous substances.
- Decontaminate affected parts before carrying out maintenance work.



NOTICE

Disclaimer of liability

Pfeiffer Vacuum accepts no liability for personal injury or material damage, losses or operating malfunctions due to improperly performed maintenance. The liability and warranty entitlement expires.

7.1 Maintenance intervals and responsibilities

- Clean the turbopump externally with a lint-free cloth and little industrial alcohol.
- Replace the operating fluid reservoir and electronic drive unit yourself.
- Change the operating fluid reservoir at least every 4 years.
- Change the turbopump bearing at least every 4 years.
 - Contact Pfeiffer Vacuum Service.
- Clarify shorter maintenance intervals for extreme loads or impure processes with Pfeiffer Vacuum Service.
- For all other cleaning, maintenance or repair work, please contact your Pfeiffer Vacuum service location.

7.2 Replacing the operating fluid reservoir

There is no need to use any poroplast rods for the exchange of the operating fluid reservoir of the turbopump.



WARNING

Poisoning hazard through contact with materials that damage health.

The operating fluid reservoir and parts of the pump may contain toxic substances from the pumped media.

- Dispose of operating fluid reservoir in accordance with the applicable regulations. Safety data sheet on request or under www.pfeiffer-vacuum.com
- Prevent health hazards or environmental damage due to contamination by means of appropriate safety precautions.
- Decontaminate affected parts before carrying out maintenance work.



Operating fluid filling

The operating fluid reservoir is sufficiently filled with operating fluid.

- Do not add additional operating fluid.
- Turn off the vacuum pump, vent to atmospheric pressure and allow to cool.
- Remove the vacuum pump from the system, if necessary.
- Close the flange openings by using the original protective covers.
- Turn the turbopump over onto the closed high vacuum flange.

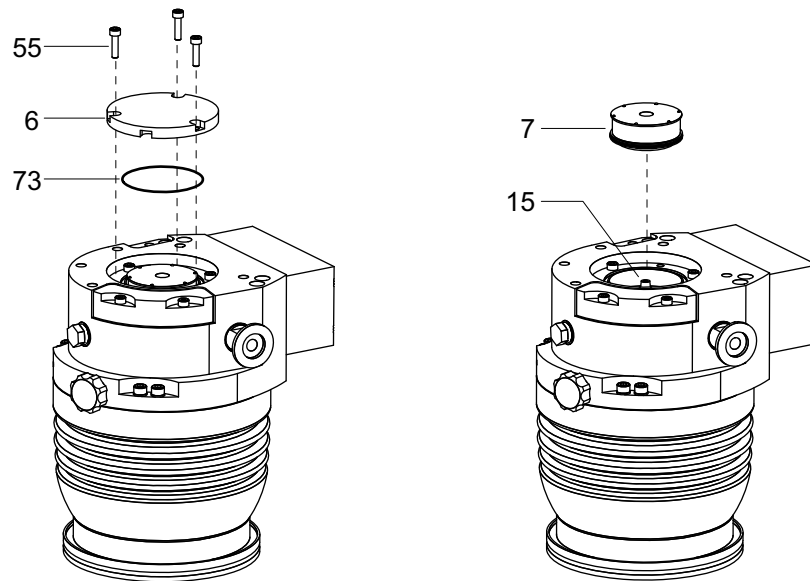

Fig. 14: Assembly / Disassembly of the operating fluid reservoir

6	End cover	15	Splash spike	73	O-ring
7	Operating fluid reservoir	55	Allen head screw		

- Screw out the Allen head screws (3x) from the end cover at the bottom of the turbopump.
- Remove the end cover. Pay attention to the O-ring.
- Remove the operating fluid reservoir out of the bearing cartridge.
- Remove impurities from the turbopump and the end cover with a clean, lint-free cloth.
Do not use any cleaning fluids!
- **Do not** use the Poroplast rods available in the spare parts kit!
- Install the new operating fluid reservoir in the bearing mounting of the turbopump with the felt side oriented toward the nozzle tip.
- For the HiPace turbopumps the operating fluid reservoir can be inserted completely into the bearing cartridge.
- Screw in the end cover with the new O-ring.
 - Tightening torque: **2.5 Nm**.

7.3 Replacing the electronic drive unit



NOTICE

Damages to the pump and drive

Even after the mains power is switched off, the subsequently running pump delivers electric power to the electronic drive unit. There is a danger of electric body contact by premature separating the pump from the electronic drive unit.

- Never separate the electronic drive unit from the pump when the mains power is connected or the rotor is running.



Operating parameters of the electronic drive unit

The factory operating parameters are always preset with replacement shipments.

- The use of a HPU enables the storing and the reuse of an existing parameter record.
- Reset any individually changed application parameters.
- Refer to the manual "Electronic drive unit".

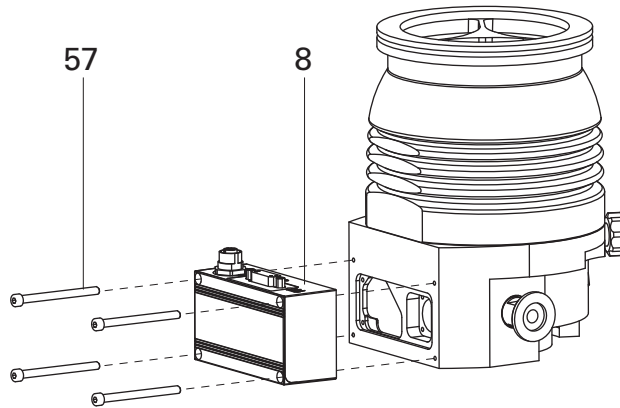

Fig. 15: Assembly / disassembly of the TC 110

8 Electronic drive unit 57 Allen head screw

- Do not exercise any mechanical load on the electronic drive unit.
- Turn off the vacuum pump, vent to atmospheric pressure and allow to cool.
- Only separate the pump and the electronic drive unit from each other after disconnecting the supply voltage and the complete standstill of the pump.
- Remove the vacuum pump from the system, if necessary.
- Unscrew Allen head screws (4x) from the electronic drive unit.
- Pull the electronic drive unit off the pump.
- Don't touch any electrostatic sensitive devices.
- Screw on and connect new electronic drive unit to the turbopump.
 - Tightening torque: **0.6 - 0.8 Nm**.

7.3.1 Rotation speed set value

The typical nominal rotation speed of a turbopump is factory-set in the electronic drive unit. If the electronic drive unit is replaced or a different pump type is used, the reference set value of the nominal rotation speed must be confirmed. This procedure is part of a redundant safety system for avoiding excess rotation speeds.

HiPace	Nominal rotation speed confirmation [P:777]
300	1000 Hz
400 / 700 / 800	820 Hz

- Adjust the parameter **[P:777]** according to the pump type.
- **Alternatively:** If no display and control unit is available, please use the "SpeedConfigurator" of the spare parts delivery.

8 Decommissioning

8.1 Shutting down for longer periods



WARNING

Contamination of parts and operating fluid by pumped media is possible.

Poisoning hazard through contact with materials that damage health.

- In the case of contamination, carry out appropriate safety precautions in order to prevent danger to health through dangerous substances.
- Decontaminate affected parts before carrying out maintenance work.

If the turbopump should be shut down for longer than a year:

- Remove the vacuum pump from the system, if necessary.
- Change the operating fluid reservoir.
- Close the high vacuum flange of the turbopump.
- Evacuate turbopump via the fore-vacuum flange.
- Vent turbopump via the venting connection with oil-free, dry air or inert gas.
- Close the flange openings by using the original protective covers.
- Close further connection ports by using the corresponding protective covers.
- Place pump upright on rubber feet.
- Store the pump only indoors at temperatures between -25 °C and +55 °C.
- In rooms with moist or aggressive atmospheres, the pump must be airtight shrink-wrapped in a plastic bag together with a bag of desiccant.

8.2 Re-starting



NOTICE

Wiederinbetriebnahme

Die Gebrauchsfähigkeit des Betriebsmittels der Turbopumpe beträgt ohne Betrieb max. 4 Jahre. Vor der Inbetriebnahme nach Stillsetzen für **4 Jahre oder länger** folgende Arbeiten durchführen:

- Betriebsmittelspeicher austauschen
- Lagerwechsel vornehmen lassen
- Wartungshinweise beachten und Pfeiffer Vacuum Service verständigen

- Check turbopump for contamination and moisture.
- Clean the turbopump externally with a lint-free cloth and little industrial alcohol.
- If necessary, have Pfeiffer Vacuum Service clean the turbopump completely.
- If necessary, have the bearings replaced. Take into account the total running time.
- Change the operating fluid reservoir.
- Installation and commissioning in accordance with the operating instructions.

8.3 Disposal

Products or parts thereof (mechanical and electrical components, operating fluids, etc.) may cause environmental burden.

- Safely dispose of the materials according to the locally applicable regulations.

9 Malfunctions

If malfunctions on the pump occur, you will find possible causes and instructions for repair in the following table.

9.1 Rectifying malfunctions

Problem	Possible causes	Remedy
Pump will not start; none of the built-in LEDs on the TC 110 lights up	• Electrical supply interrupted	⇒ Check plug contacts on the power supply ⇒ Check supply lines on the power supply ⇒ Check the output voltage (24 V DC) on the connection "DC out" of the power supply ⇒ Check the plug contacts on the TC
	• Operating voltage incorrect	⇒ Apply correct operating voltage ⇒ Observe the rating plate
	• No operating voltage applied	⇒ Apply operating voltage
	• TC 110 defective	⇒ Exchange the TC 110 ⇒ Contact the Pfeiffer Vacuum Service
Pump will not start; green LED on the TC 110 is flashing	• At operation without control panel: Pins 2-7 and 5-7 are not connected on the "X3" connection	⇒ Connect the pins 2-7 and 5-7 on the "X3" connection
	• At operation via RS-485: Bridge at Pin 2-7 prevents control commands	⇒ Remove the bridge at the "X3" connection.
	• At operation via RS-485: Parameters of the electronic drive unit not set	⇒ Set parameters [P: 010] and [P: 023] "ON" via interface RS-485. ⇒ Please refer to operating instructions of the electronic drive unit.
	• Voltage drop in the cable too high	⇒ Use a suitable cable
Pump does not attain the final rotational speed within the specified run-up time	• Fore-vacuum pressure too high	⇒ Ensure function and suitability of the backing pump
	• Leak	⇒ Perform leak detection ⇒ Check sealings and flange fastenings ⇒ Eliminate leaks
	• Gas throughput too high	⇒ Reduce process gas supply
	• Rotor is rough-running, bearing defective	⇒ Check the bearing for noises ⇒ Contact the Pfeiffer Vacuum Service
	• Setpoint for run-up time to low	⇒ Extend the run-up time via DCU, HPU or PC
	• Thermal overload: – Lack of air ventilation – Water flow too low – Fore-vacuum pressure too high – Ambient temperature too high	⇒ Reduce thermal loads – Ensure adequate cooling – Ensure the cooling water flow – Lower the fore-vacuum pressure – Adjust ambient conditions
	• Pump is dirty	⇒ Bake out the pump ⇒ Cleaning in case of heavy contamination – Contact the Pfeiffer Vacuum Service
Pump does not attain the ultimate pressure	• Vacuum chamber, pipes or pump are leaky	⇒ Leak detection starting from the vacuum chamber ⇒ Eliminate leaks
	• Bearing damage	⇒ Contact the Pfeiffer Vacuum Service
Unusual noises during operation	• Rotor damage	⇒ Contact the Pfeiffer Vacuum Service
	• Splinter shield or protective screen are loose	⇒ Correct the seat of the splinter shield or the protective screen ⇒ Observe the installation notes
	• Collective fault	⇒ Reset by switching the mains OFF/ON ⇒ Reset via pin 6 on the "X3" connection ⇒ Differentiated malfunction display is possible via DCU or HPU ¹⁾ ⇒ Contact the Pfeiffer Vacuum Service

¹⁾ If no display and control unit is available, please contact the Pfeiffer Vacuum Service.

10 Service

Pfeiffer Vacuum offers first-class service!

- Operating fluid and bearing change on the spot by Pfeiffer Vacuum FieldService
- Maintenance / repair in the nearby ServiceCenter or ServicePoint
- Fast replacement with exchange products in mint condition
- Advice on the most cost-efficient and quickest solution

Detailed information, addresses and forms at: www.pfeiffer-vacuum.com (Service).

Maintenance and repair in the Pfeiffer Vacuum ServiceCenter

The following steps are necessary to ensure a fast, smooth servicing process:

- Download the forms "Service Request" and "Declaration on Contamination".¹⁾
- Fill out the "Service Request" form and send it by fax or e-mail to your Pfeiffer Vacuum service address.
- Include the confirmation on the service request from Pfeiffer Vacuum with your shipment.
- Fill out the declaration on contamination and include it in the shipment (required!).
- Dismantle all accessories.
- Drain the operating fluid (applies for turbopumps with pumping speed > 800 l/s).
- Leave electronic drive on the pump.
- Close the flange openings by using the original protective covers.
- If possible, send pump or unit in the original packaging.

Sending of contaminated pumps or devices

No units will be accepted if they are contaminated with micro-biological, explosive or radioactive substances. "Hazardous substances" are substances and compounds in accordance with the hazardous goods directive (current version). If pumps are contaminated or the declaration on contamination is missing, Pfeiffer Vacuum performs decontamination at the shipper's expense.

- Neutralise the pump by flushing it with nitrogen or dry air.
- Close all openings airtight.
- Seal the pump or unit in suitable protective film.
- Return the pump/unit only in a suitable and sturdy transport container and send it in while following applicable transport conditions.

Exchange unit

The factory operating parameters are always preset with exchange units. If you use changed parameters for your application, you have to set these again.

Service orders

All service orders are carried out exclusively according to our repair conditions for vacuum units and components.

¹⁾ Forms under www.pfeiffer-vacuum.com

11 Spare parts HiPace 300 Plus

Item	Designation	Order number	Notes	Pieces	Order qty
7	Operating fluid reservoir	PM 143 451 -T		1	
8	Electronic drive unit TC 110	according to the rating plate	depends on the model	1	

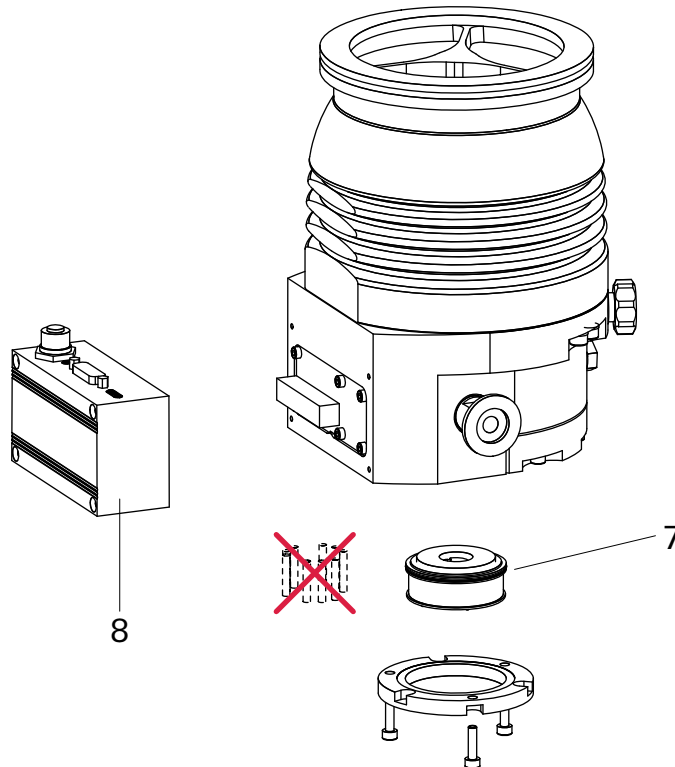

There is no need to use any poroplast rods for the exchange of the operating fluid reservoir of the turbopump.

→ **Do not** use the Poroplast rods available in the spare parts kit!

Please also specify model number of the the rating plate when ordering accessories or spare parts.

12 Accessories

Designation	HiPace® 300 Plus, DN 100 ISO-K	HiPace® 300 Plus, DN 100 CF-F	HiPace® 300 Plus, DN 100 ISO-F
TPS 180, mains pack for wall/standard rail fitting	PM 061 341 -T	PM 061 341 -T	PM 061 341 -T
TPS 181, mains pack 19" rack module 3HU	PM 061 345 -T	PM 061 345 -T	PM 061 345 -T
DCU 180, Display control unit incl. power supply	PM C01 821	PM C01 821	PM C01 821
DCU 002, Display Control Unit	PM 061 348 -T	PM 061 348 -T	PM 061 348 -T
HPU 001, Handheld Programming Unit	PM 051 510 -T	PM 051 510 -T	PM 051 510 -T
Accessories package for HPU 001/PC	PM 061 005 -T	PM 061 005 -T	PM 061 005 -T
Mains cable 230 V AC, CEE 7/7 to C13, 3 m	P 4564 309 ZA	P 4564 309 ZA	P 4564 309 ZA
Mains cable 115 V AC, NEMA 5-15 to C13, 3 m	P 4564 309 ZE	P 4564 309 ZE	P 4564 309 ZE
Mains cable 208 V AC, NEMA 6-15 to C13, 3 m	P 4564 309 ZF	P 4564 309 ZF	P 4564 309 ZF
TCS 12, adapter for TC 110/120 with interface RS-485, 4 accessory ports and coupling set	PM 061 638 -U	PM 061 638 -U	PM 061 638 -U
TCS 11, adapter for TC 110/120 with RS-485 interface	PM 061 636 -U	PM 061 636 -U	PM 061 636 -U
TCS 15 for controlling backing pumps	PM 061 685 -X	PM 061 685 -X	PM 061 685 -X
Connection cable with RS-485 interface and 2 accessory ports for TC110/120 to power supply	PM 061 351 -T	PM 061 351 -T	PM 061 351 -T
Connection cable with RS-485 interface for TC 110/120 to power supply	PM 061 350 -T	PM 061 350 -T	PM 061 350 -T
USB converter to RS-485 interface	PM 061 207 -T	PM 061 207 -T	PM 061 207 -T
Interface cable, M12 m straight/M12 m straight, 3 m	PM 061 283 -T	PM 061 283 -T	PM 061 283 -T
Y-Connector M12 to RS-485	P 4723 010	P 4723 010	P 4723 010
Relay box, shielded, for backing pumps, 1-phase 7A for TC 110/120 and TCP 350, plug M8	PM 071 282 -X	PM 071 282 -X	PM 071 282 -X
Relay box for backing pump, single phase 20 A for TC 110/120 and TCP 350, M8 plug	PM 061 373 -T	PM 061 373 -T	PM 061 373 -T
TVV 001 fore-vacuum safety valve, 115 V AC	PM Z01 206	PM Z01 206	PM Z01 206
TVV 001 fore-vacuum safety valve, 230 V AC	PM Z01 205	PM Z01 205	PM Z01 205
HiPace - ACP connection cable	PM 071 142 -X	PM 071 142 -X	PM 071 142 -X
Heating jacket for HiPace 300 with TC 110, 230 V AC, safety plug		PM 061 363 -T	
Heating jacket for HiPace 300 with TC 110, 208 V AC, UL plug		PM 061 364 -T	
Heating jacket for HiPace 300 with TC 110, 115 V AC, UL plug		PM 061 365 -T	
Air cooling for HiPace 300/450 with TC 110/120	PM Z01 301	PM Z01 301	PM Z01 301
Water cooling for HiPace 300 with push-in fitting 8 mm	PM 016 624 -T	PM 016 624 -T	PM 016 624 -T
Venting valve, shielded, 24 V DC, G 1/8", for connection to TC 110/120	PM Z01 290	PM Z01 290	PM Z01 290
TTV 001, dryer for venting turbopumps	PM Z00 121	PM Z00 121	PM Z00 121
Sealing gas valve, shielded for HiPace 300 with TC 110/120	PM Z01 311	PM Z01 311	PM Z01 311
Sealing gas throttle for HiPace 300	PM Z01 317	PM Z01 317	PM Z01 317
Centering ring with multifunction coating, DN 100 ISO-K/-F	PM 016 210 -U		PM 016 210 -U
Centering ring with multifunction coating and integrated protection screen, DN 100 ISO-K/-F	PM 016 212 -U		PM 016 212 -U
Centering ring with multifunction coating and integrated splinter shield, DN 100 ISO-K/-F	PM 016 211 -U		PM 016 211 -U
Protection screen for DN 100 CF-F		PM 016 336	
Splinter shield for turbopumps, DN 100 CF-F		PM 016 315	
Vibration isolator for DN 100 ISO-F/K	PM 016 600 -U		PM 016 600 -U
Vibration isolator for DN 100 CF-F		PM 016 715 -U	
Vibration damper for HiPace 300/400, DN 100 ISO-K/F	PM 006 459 -X		PM 006 459 -X
Vibration damper for HiPace 300/400, DN 100 CF-F		PM 006 488 -X	
Mounting kit for HiPace 300, DN 100 ISO-K, including coated centering ring, protection screen and bracket screws	PM 016 367 -T		
Mounting kit for HiPace 300, DN 100 ISO-K, including coated centering ring, splinter shield and bracket screws	PM 016 366 -T		
Mounting kit for HiPace 300 with DN 100 ISO-K, including coated centering ring and bracket screws	PM 016 365 -T		
Set of stud screws for through hole, DN 100 CF-F		PM 016 734 -T	
Set of hexagon screws for through hole, DN 100 CF-F		PM 016 690 -T	
Set of stud screws for tapped hole, DN 100 CF-F		PM 016 866 -T	
Mounting kit for DN 100 ISO-F, including coated centering ring, hexagon screws			PM 016 450 -T

Accessories

Designation	HiPace® 300 Plus, DN 100 ISO-K	HiPace® 300 Plus, DN 100 CF-F	HiPace® 300 Plus, DN 100 ISO-F
Mounting kit for DN 100 ISO-F, including coated centering ring, splinter shield, hexagon screws			PM 016 451 -T
Mounting kit for DN 100 ISO-F, including coated centering ring, protective screen, hexagon screws			PM 016 452 -T
Mounting kit for DN 100 ISO-F, including coated centering ring, stud screws			PM 016 455 -T
Mounting kit for DN 100 ISO-F, including coated centering ring, splinter shield, stud screws			PM 016 456 -T
Mounting kit for DN 100 ISO-F, including coated centering ring, protection screen, stud screws			PM 016 457 -T

13 Technical data and dimensions

13.1 General

Basic principles for the Technical Data of Pfeiffer Vacuum Turbopumps:

Maximum values refer exclusively to the input as a single load.

- Recommendations of PNEUROP committee PN5
- ISO 21360; 2007: "Vacuum technology - Standard methods for measuring vacuum-pump performance - General description"
- ISO 5302; 2003: "Vacuum technology - Turbomolecular pumps - Measurement of performance characteristics"
- Ultimate pressure: using a test dome and a 48 hrs. period of baking out
- Gas throughput: at water cooling, cooling water temp. 25 °C; backing pump = rotary vane pump (10 m³/h)
- Cooling water consumption: at max. gas throughput, cooling water temp. 25 °C
- Integral leak rate: using a Helium concentration of 100 %, period 10 s
- Sound pressure level: Distance 1 m to the pump

Conversion table: pressure units

	mbar	bar	Pa	hPa	kPa	Torr mm Hg
mbar	1	$1 \cdot 10^{-3}$	100	1	0.1	0.75
bar	1000	1	$1 \cdot 10^5$	1000	100	750
Pa	0.01	$1 \cdot 10^{-5}$	1	0.01	$1 \cdot 10^{-3}$	$7.5 \cdot 10^{-3}$
hPa	1	$1 \cdot 10^{-3}$	100	1	0.1	0.75
kPa	10	0.01	1000	10	1	7.5
Torr mm Hg	1.33	$1.33 \cdot 10^{-3}$	133.32	1.33	0.133	1

$$1 \text{ Pa} = 1 \text{ N/m}^2$$

Conversion table: gas throughput units

	mbar-l/s	Pa·m ³ /s	sccm	Torr-l/s	atm·cm ³ /s
mbar-l/s	1	0.1	59.2	0.75	0.987
Pa·m ³ /s	10	1	592	7.5	9.87
sccm	$1.69 \cdot 10^{-2}$	$1.69 \cdot 10^{-3}$	1	$1.27 \cdot 10^{-2}$	$1.67 \cdot 10^{-2}$
Torr-l/s	1.33	0.133	78.9	1	1.32
atm·cm ³ /s	1.01	0.101	59.8	0.76	1

13.2 Technical data

Parameter	HiPace® 300 Plus	HiPace® 300 Plus	HiPace® 300 Plus
Flange (in)	DN 100 ISO-K	DN 100 CF-F	DN 100 ISO-F
Flange (out)	DN 16 ISO-KF / G 1/4"	DN 16 ISO-KF / G 1/4"	DN 16 ISO-KF / G 1/4"
Pumping speed for Ar	255 l/s	255 l/s	255 l/s
Pumping speed for H ₂	220 l/s	220 l/s	220 l/s
Pumping speed for He	255 l/s	255 l/s	255 l/s
Pumping speed for N ₂	260 l/s	260 l/s	260 l/s
Compression ratio for Ar	$> 1 \cdot 10^{11}$	$> 1 \cdot 10^{11}$	$> 1 \cdot 10^{11}$
Compression ratio for H ₂	$9 \cdot 10^5$	$9 \cdot 10^5$	$9 \cdot 10^5$
Compression ratio for He	$> 1 \cdot 10^8$	$> 1 \cdot 10^8$	$> 1 \cdot 10^8$
Compression ratio for N ₂	$> 1 \cdot 10^{11}$	$> 1 \cdot 10^{11}$	$> 1 \cdot 10^{11}$
Gas throughput at full rotational speed for Ar	2 hPa l/s	2 hPa l/s	2 hPa l/s
Gas throughput at full rotational speed for He	8 hPa l/s	8 hPa l/s	8 hPa l/s
Gas throughput at full rotational speed for H ₂	> 14 hPa l/s	> 14 hPa l/s	> 14 hPa l/s
Gas throughput at full rotational speed for N ₂	5 hPa l/s	5 hPa l/s	5 hPa l/s
Fore-vacuum max. for Ar	15 hPa	15 hPa	15 hPa
Fore-vacuum max. for H ₂	8.5 hPa	8.5 hPa	8.5 hPa
Fore-vacuum max. for He	15 hPa	15 hPa	15 hPa
Fore-vacuum max. for N ₂	15 hPa	15 hPa	15 hPa
Run-up time	3.5 min	3.5 min	3.5 min
Ultimate pressure according to PNEUROP	$< 1 \cdot 10^{-7}$ hPa	$< 5 \cdot 10^{-10}$ hPa	$< 1 \cdot 10^{-7}$ hPa
Rotation speed ± 2 %	60000 min ⁻¹	60000 min ⁻¹	60000 min ⁻¹
Rotation speed variable	35-100 %	35-100 %	35-100 %
Power characteristic line in gas mode 1, vertex A	150/60000 W/min ⁻¹	150/60000 W/min ⁻¹	150/60000 W/min ⁻¹
Power characteristic line in gas mode 1, vertex B	150/54000 W/min ⁻¹	150/54000 W/min ⁻¹	150/54000 W/min ⁻¹
Power characteristic line in gas mode 0, vertex C	150/60000 W/min ⁻¹	150/60000 W/min ⁻¹	150/60000 W/min ⁻¹
Power characteristic line in gas mode 0, vertex D	150/54000 W/min ⁻¹	150/54000 W/min ⁻¹	150/54000 W/min ⁻¹
Power characteristic line in gas mode 2, vertex E	150/60000 W/min ⁻¹	150/60000 W/min ⁻¹	150/60000 W/min ⁻¹
Power characteristic line in gas mode 2, vertex F	150/54000 W/min ⁻¹	150/54000 W/min ⁻¹	150/54000 W/min ⁻¹
Sound pressure level	≤ 50 dB (A)	≤ 50 dB (A)	≤ 50 dB (A)
Relative humidity of air	5-85, non-condensing %	5-85, non-condensing %	5-85, non-condensing %
Protection category	IP54	IP54	IP54
Connection pressure max. for venting/sealing gas valve	1500 hPa	1500 hPa	1500 hPa
Drive power max.	150 W	150 W	150 W
Operating voltage	24 V DC	24 V DC	24 V DC
Operating voltage power supply	90-265 V AC	90-265 V AC	90-265 V AC
Integral leak rate	$< 1 \cdot 10^{-8}$ Pa m ³ /s	$< 1 \cdot 10^{-8}$ Pa m ³ /s	$< 1 \cdot 10^{-8}$ Pa m ³ /s
Power consumption max.	180 W	180 W	180 W
Current consumption max.	7.5 A	7.5 A	7.5 A
Mounting orientation	vertical, flange up	vertical, flange up	vertical, flange up
Venting connection	G 1/8"	G 1/8"	G 1/8"
Weight	5.8 kg	7.8 kg	6.1 kg
Cooling method, standard	Air	Air	Air
Cooling method, optional	Water	Water	Water
Cooling water temperature	15-35 °C	15-35 °C	15-35 °C
Cooling water consumption	50 l/h	50 l/h	50 l/h
Permissible irradiated thermal power max.	2.4 W	2.4 W	2.4 W
Permissible magnetic field max.	5.5 mT	5.5 mT	5.5 mT
Interfaces	RS-485, Remote	RS-485, Remote	RS-485, Remote

13.3 Dimensions

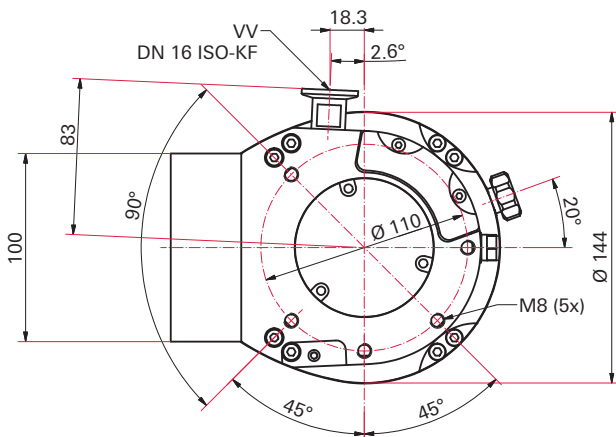

Fig. 16: HiPace 300 Plus, DN 100 ISO-K

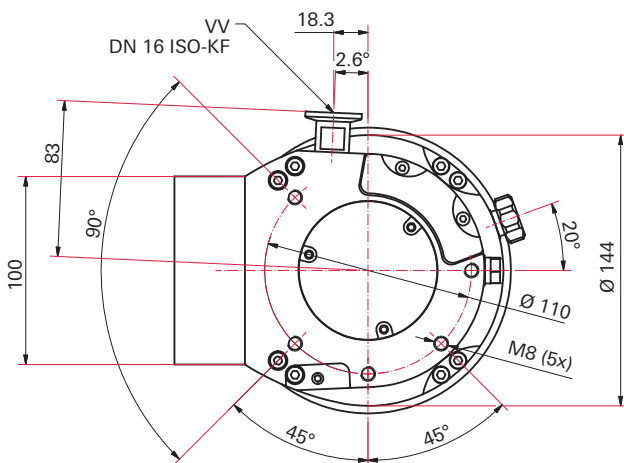
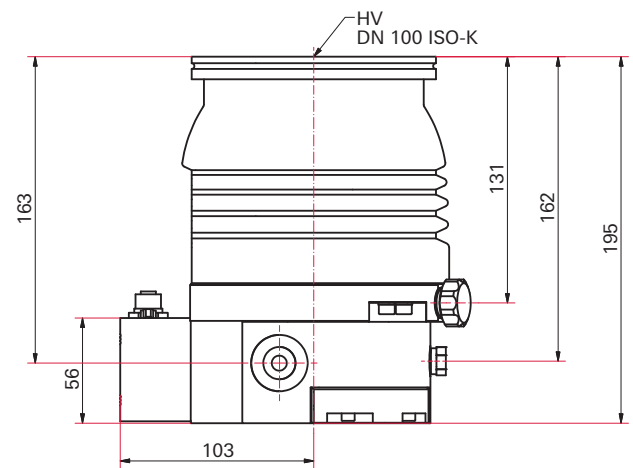

Fig. 17: HiPace 300 Plus, DN 100 CF-F

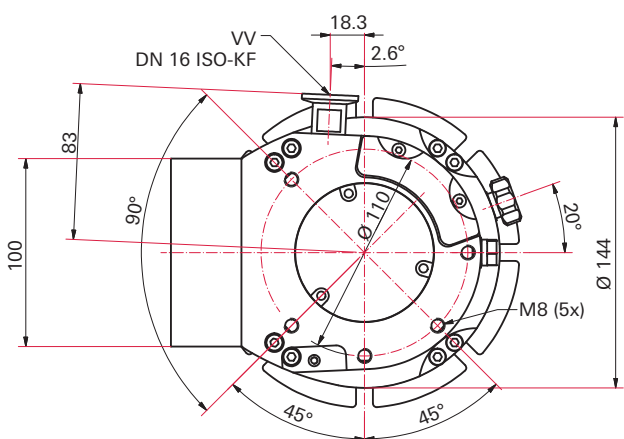
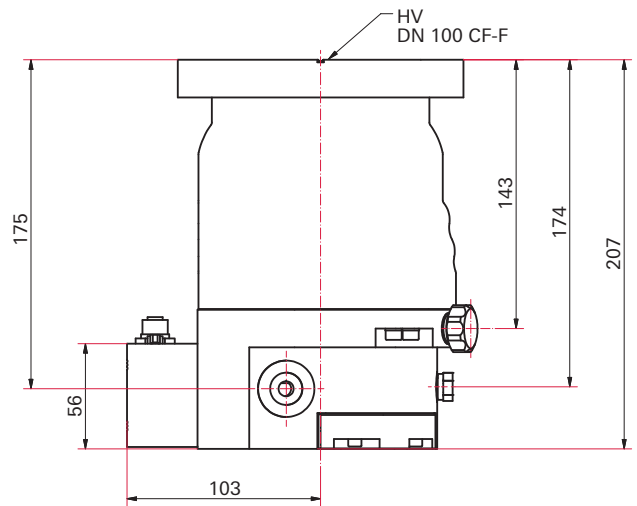
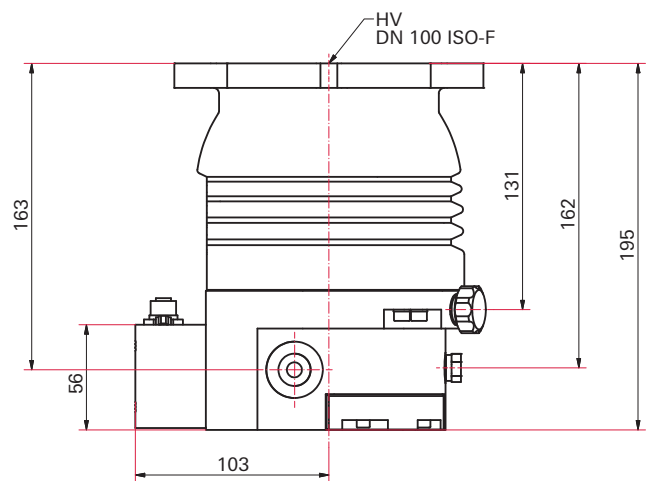

Fig. 18: HiPace 300 Plus, DN 100 ISO-F





Declaration of conformity

We hereby declare that the product cited below satisfies all relevant provisions according to the following **EC directives**:

- **Machinery 2006/42/EC (Annex II, no. 1 A)**
- **Electromagnetic Compatibility 2014/30/EU**
- **Restriction of the use of certain Hazardous Substances 2011/65/EU**

The agent responsible for compiling the technical documentation is Mr. Helmut Bernhardt, Pfeiffer Vacuum GmbH, Berliner Straße 43, 35614 Asslar.

HiPace 300 Plus

Harmonised standards and national standards and specifications which have been applied:

DIN EN ISO 12100 : 2011
DIN EN 1012-2 : 2011
DIN EN 50581 : 2013
DIN EN 61000-3-2 : 2014
DIN EN 61000-3-3 : 2013
DIN EN 61010-1 : 2010
DIN EN 61326-1 : 2013
DIN EN 62061 : 2013

Signature:

Pfeiffer Vacuum GmbH
Berliner Straße 43
35614 Asslar
Germany

(Dr. Ulrich von Hülsen)
Managing Director

Asslar, 2017-10-24

VACUUM SOLUTIONS FROM A SINGLE SOURCE

Pfeiffer Vacuum stands for innovative and custom vacuum solutions worldwide, technological perfection, competent advice and reliable service.

COMPLETE RANGE OF PRODUCTS

From a single component to complex systems:

We are the only supplier of vacuum technology that provides a complete product portfolio.

COMPETENCE IN THEORY AND PRACTICE

Benefit from our know-how and our portfolio of training opportunities!

We support you with your plant layout and provide first-class on-site service worldwide.

Are you looking for a
perfect vacuum solution?
Please contact us:

Pfeiffer Vacuum GmbH
Headquarters • Germany
T +49 6441 802-0
info@pfeiffer-vacuum.de

www.pfeiffer-vacuum.com

PFEIFFER  **VACUUM**