

H I G H V A C U U M P U M P S



High Vacuum Pumps

▶ Compact dry
pumping systems

DRYTEL series

Compact Dry Pumping Systems

Drytel series

Dry pumping unit

Drytel units are dry pumping systems including an Alcatel molecular drag pump (MDP) and an oil-free forepump. Designed to be used as bench top or easily integrated in a system, these units provide a dry clean vacuum from atmosphere to 10^{-6} mbar/Torr.

Small pumping configuration: Drytel 1025

p 4 à 7

Based on the new "Open Concept", this unique, small and robust pumping system provides a suitable solution for backing turbomolecular pumps or pumping a system down to 10^{-6} mbar/Torr. The Drytel 1025 accommodates a 7.5 l/s drag pump and a 1 m³/h diaphragm pump in a compact design.



Drytel 1025

Large pumping configuration: Drytel 34 / Drytel 100

p 8 à 11

Already used on numerous types of systems, these units are suitable for all applications which require a fast pumpdown time. The Drytel 34 accommodates a 7.5 l/s drag pump and a 4 m³/h diaphragm pump. The Drytel 100 accommodates a 24 l/s drag pump and a 4 m³/h diaphragm pump.



Drytel 34

Applications

Drytel series is recommended for all applications where a dry clean vacuum is required such as in industries (semiconductor, analytical instrumentation, pharmaceutical, chemicals, ...) and in Research and Development laboratories.

They can be used in various types of applications:

- Backing of turbomolecular pump
- Loadlock pumping
- Mass spectrometry
- Surface analysis
- Ion pump evacuation
- Cryopump regeneration
- Calibration bench
- ...

Compact Dry Pumping Systems



Drytel series

“Open Concept” : a new generation of Alcatel’s turbo pumping group...

 <ul style="list-style-type: none">• OPEN Design• OPEN Configuration• OPEN Applications	<p>Main advantages of the “Open Concept”</p> <ul style="list-style-type: none">• Flexible possibility to get the most adapted configuration• Compact• Easy to maintain direct access to the main components• Cost effective <p>As a part of the “Open Concept” family, the Drytel 1025 has been designed to offer various configurations. Please consult your Alcatel’s representative for more information on the available configurations.</p>
---	--

High Vacuum Pumps

Benefits

<p>NO CONTAMINATION FROM INTERNAL LUBRICANT</p>		<p>The two pumping stages working in series (MDP + diaphragm pump) don’t require any fluid to operate, permitting use on ultra clean processes.</p>
<p>HIGH RELIABILITY</p>		<p>Drytel series accomodates well proven vacuum pumps :</p> <ul style="list-style-type: none">• Alcatel molecular drag pump rotating at low rotationnal speed• Rugged diaphragm pumps, already used by industry in thousands of harsh environments.
<p>COST EFFECTIVE SOLUTION</p>		<p>Drytel series is the least expensive solution to achieve a clean vacuum down to 10^{-6} mbar/Torr.</p>



Compact Dry Pumping Systems

Drytel series

Small pumping configuration: Drytel 1025

The Drytel 1025 is the first member of a new family based on the "Open Concept".

The Drytel 1025 is a new, small and robust pumping system which provides a suitable solution for backing turbomolecular pumps or pumping a system down to 10^{-6} mbar/Torr.

It accommodates a 7.5 l/s drag pump and a 1.5 m³/h diaphragm pump in a compact design.



High Vacuum Pumps



MDP 5011 (7.5 l/s)
integrated on the Drytel 1025



New 1.5 m³/h diaphragm pump

Compact Dry Pumping Systems

Drytel series

Technical data

Pumping speed / Inlet pressure (N₂)

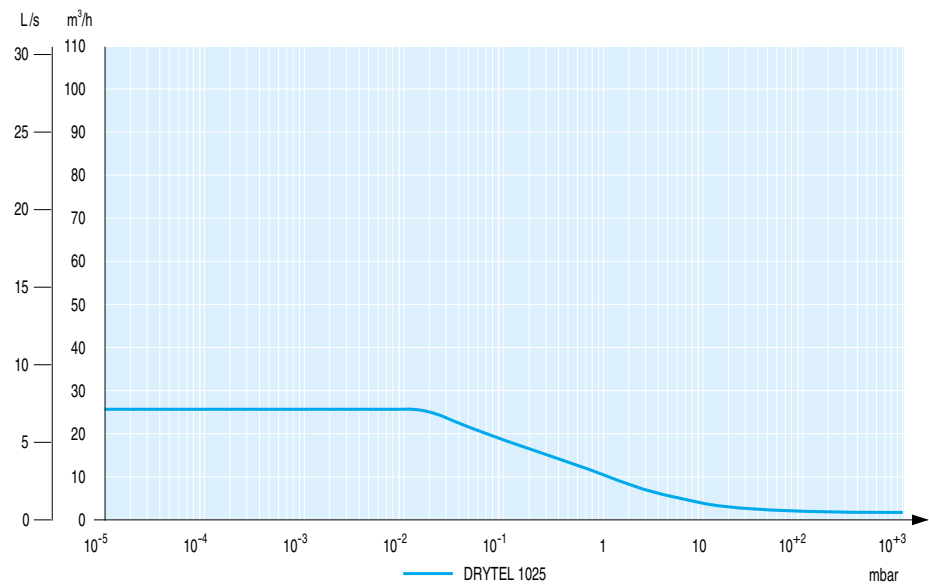

HIGH VACUUM PUMPS

Pump down curves on a 30 l volume of N₂

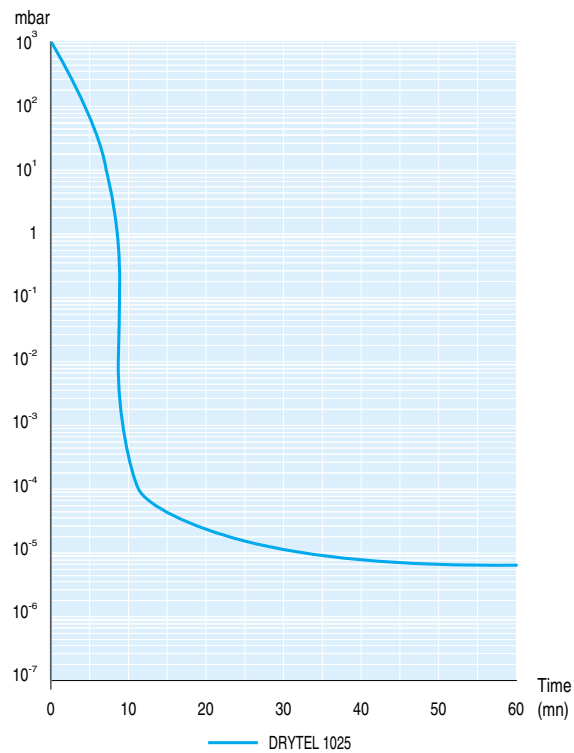

Compact Dry Pumping Systems

Drytel series

Technical data

Characteristics		Drytel 1025
Ultimate pressure*	mbar	10 ⁻⁶
Pumping speed < 10 ⁻² mbar*	N ₂ l/s	7.5
	He l/s	4
	H ₂ l/s	3
Primary module pumping speed	m ³ /h	1
Exhaust pressure	mbar	Atmosphere
Start-up time	min	2 min
Cooling system		Air
Maximum inlet pressure	mbar	5
Maximum ambient temperature	°C	0 to 35
Maximum power consumption	VA	250
Inlet flange		DN 63 ISO-K
Weight	kg (lb)	15 (33)

* Pneuop measurement

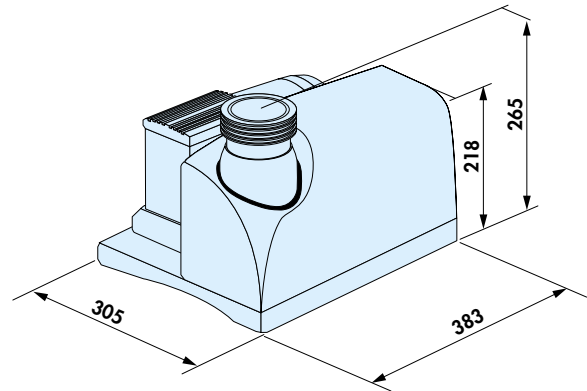

Dimensions in mm

High Vacuum Pumps

Options and accessories

Options

It is possible to fit the Drytel 1025 with several types of options:

- Interface board: allows the remote operation of the Drytel (start/stop and monitoring of the pumping system status),
- Automatic gas ballast: improves the pumping of light gases and reduces the condensation inside the Drytel,
- Exhaust connection: allows the collection of pumped gases to prevent their release to the atmosphere.

Accessories

Various accessories dedicated to the molecular drag pump can be offered as options. In particular, the inlet screen can be used to prevent foreign material to enter the pump.

Description	P/N
Inlet screen (DN 63) - 2.5 mm mesh	063117
Inlet dust filter 20 µ (DN 63)	062912
Aluminium centering ring (DN 63) special for MDP 5011 (without o-Ring)	063212



Standard & dense mesh inlet screen

Compact Dry Pumping Systems

Drytel series

Ordering information

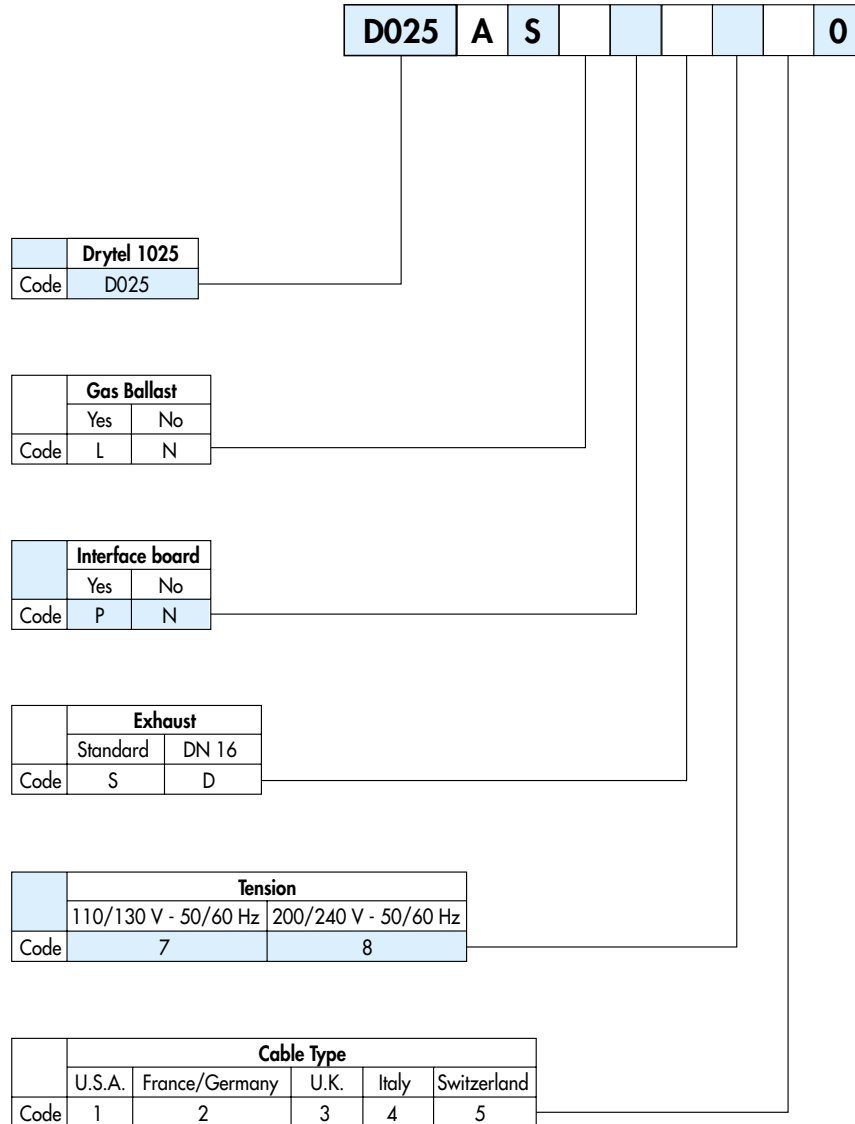

HIGH VACUUM PUMPS

For example
You need ...

Drytel	D025
Gas ballast	L
Interface board	P
Exhaust DN 16	D
110/130 V - 50/60 Hz	7
U.S.A.	1

=

D025	A	S	L	P	D	7	1	0
------	---	---	---	---	---	---	---	---

Compact Dry Pumping Systems

Drytel series

Large pumping configuration: Drytel 34 - Drytel 100

The Drytel 34 and the Drytel 100 provide large configurations for pumping down to 10^{-6} mbar/Torr at high pumping speed. They accommodate a 4 m³/h diaphragm pump and an associated molecular drag pump (MDP), according to the requested configuration. Specific versions are available for corrosive applications ("C" version equipped with a MDP chemical version).

High Vacuum Pumps

Drytel 34



Drytel 34 equipped with a 7.5 l/s drag pump

Drytel 100



Drytel 100 equipped with a 27 l/s drag pump "C" version

Technical data

Characteristics		Drytel 34/34 C		Drytel 100/100 C	
Ultimate pressure*	mbar	$10^{-6}/10^{-5}$		10^{-6}	
Pumping speed < 10^{-2} mbar*	N ₂	l/s	7.5	27	
	He	l/s	4	18	
	H ₂	l/s	3	15	
Primary module pumping speed	m ³ /h	4		4	
Exhaust pressure	atm	(10 ³ mbar)		(10 ³ mbar)	
Start-up time	min	2 min		1.5 min	
Cooling system		Air	Water	Air	Water
Maximum inlet pressure	mbar	5		5	10
Maximum ambient temperature	°C	0 to 35	0 to 50	0 to 35	0 to 45
Maximum power consumption	VA	575		650	
Inlet flange		DN 63 ISO-K		DN 100 ISO-K	
Weight	kg (lb)	36 (80)		43 (95)	

* Pneuop measurement

Compact Dry Pumping Systems

Drytel series

Technical data

Pumping speed / Inlet pressure (N₂)

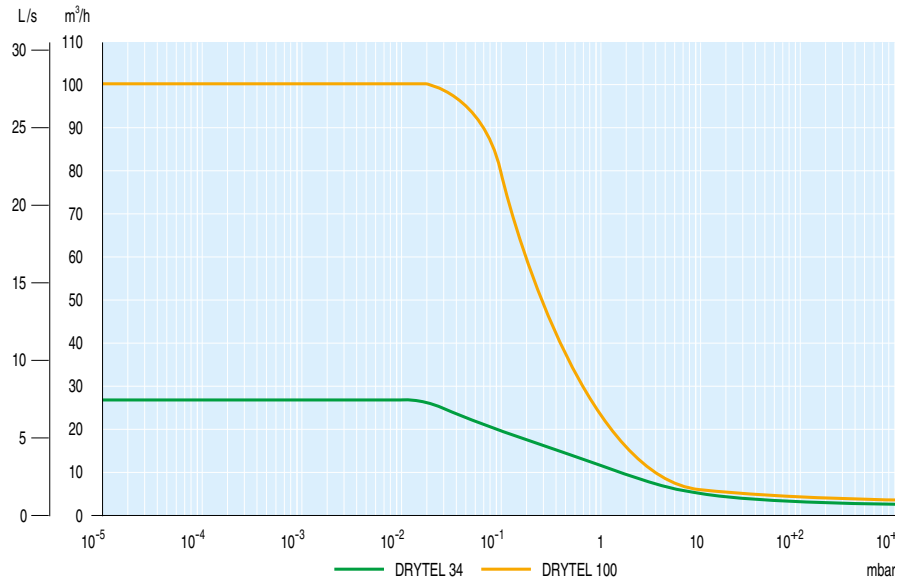

HIGH VACUUM PUMPS

Pump down curves on a 30 l volume of N₂

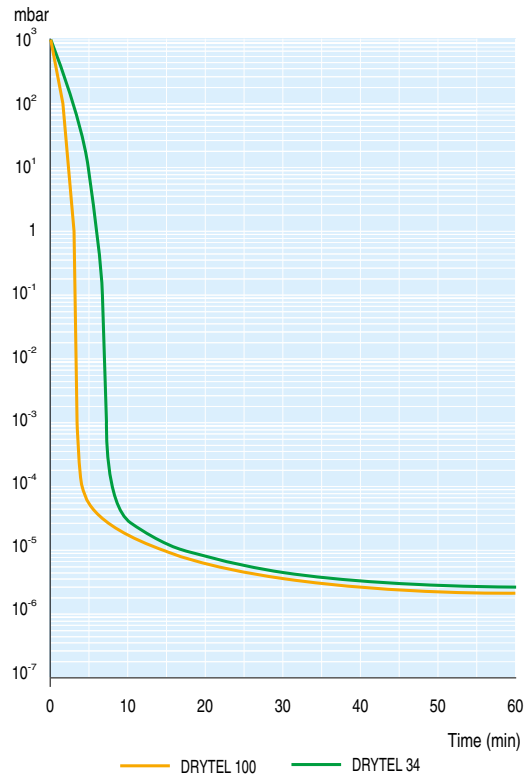

Compact Dry Pumping Systems

Drytel series

Dimensions

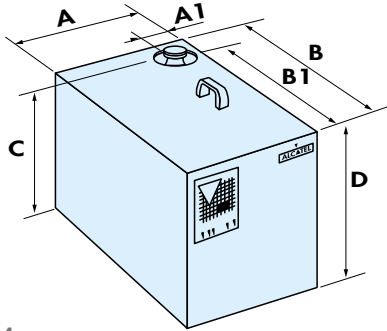

Drytel 34

Model	A	A1	B	B1	C	D
Drytel 34	280	65	450	387	375	345
Drytel 34 C	280	65	450	387	375	345

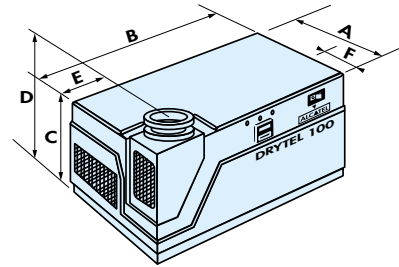

Drytel 100

Model	A	B	C	D	E	F
Drytel 100	465	625	305	350	99	93
Drytel 100 C	465	625	305	350	99	93

HIGH VACUUM PUMPS

Ordering information

Model	Flange	Cooling	Single phase			
			PART NUMBER			
			230 V (*) 50/60 HZ	115 V 60 HZ	100 V 50/60 HZ	200 V 50/60 HZ
Drytel 34	DN 63 ISO-K	Air	798619	798619	798622	798625
Drytel 100	DN 100 ISO-K	Air	795453	795454	795455	795457
		Water	795540	795541	795542	795544
Drytel 34 C	DN 63 ISO-K	Air	798614	798620	798623	798626
Drytel 100 C	DN 100 ISO-K	Air	795909	795910	795911	795913
		Water	795918	795914	795915	795917

Optional Power Cords

Description	P/N
US power cord for 230 V - 60 Hz	107404
US power cord for 230 V - 50 Hz	107405

(*) Delivered with European power cord, for other power cords see below

Note

The Drytel 34 and the Drytel 100 can be customer specified with additional accessories.

Compact Dry Pumping Systems

Drytel series

Options and accessories

The Drytel 34 and Drytel 100 can be specified with a comprehensive range of additional accessories to meet customer requirements. Options are factory installed: they must be specified when ordering the Drytel. Accessories can be ordered separately.

Improving the performance:

- The manual or electrical (automatic) gas ballast improves the pumping of light gases, or reduces condensation inside the Drytel.
- The standard of dense mesh inlet screen should be used to prevent foreign material to enter the high vacuum pump.

Integration in a system:

- The exhaust connection collects the pumped gases to prevent their release to the atmosphere. If the gases are corrosive, a "C" type exhaust connection is appropriate.
- A separator kit may be used to separate the high vacuum pump from the Drytel.

Control:

The interface kits allow a remote operation of the Drytel (start/stop and monitoring of the pumping system status).

Others:

In any case, please contact us directly if your specific need is not covered by a standard product. We offer product customization and integration of accessories such as valves, gauges, etc...

Drytel 100/Drytel 100 C Options

Description	Drytel		PART NUMBER
	100	100 C	
Manual gas ballast valve between MDP and dry primary pump (light gases pumping)	●	●	050590
Electrical gas ballast valve 24 V-DC (other voltages on request)	●	●	050580
Exhaust connection (DN 16)	●		050554
"C" type inert gas purge connector (DN 16 ISO-KF) and exhaust connection (DN 16)	●		062979
"C" type exhaust flange extension - Stainless steel / teflon		●	050577
Interface control	●	●	062898
Set of 4 casters	●	●	062868

Drytel 100/Drytel 100 C Accessories

Description	Drytel		PART NUMBER
	100/100 C		
Set of 4 handles	●		050590
Inlet screen (DN 100) - 2.5 mm mesh	●		050580
Inlet dust filter 20 µ (DN 100)	●		050554

Drytel 34/Drytel 34 C Accessories

Description	Drytel		PART NUMBER
	34/34 C		
Side (horizontal) inlet kit for MDP	●		050591
Air cooling flow deflector	●		050587
Inlet screen (DN 63) - 2.5 mm mesh	●		063117
Inlet dust filter 20 µ (DN 63)	●		062912
Aluminium centering ring (DN 63) special for MDP (without o-ring)	●		063212