

Operating Instructions

TPH 2201 / TPU 2201

***Turbomolecular Pumps
With Electronic Drive Units***



CE



	Page		Page
1. Safety Instructions	3	4.10. Operations With The Remote Control Unit.....	15
1.1. For Your Orientation.....	3	Venting Release (Optional).....	15
1.2. Pictogram Definitions.....	3	Motor, Turbopump	15
2. Understanding The Pumps		Pumping Station	15
TPH/TPU 2201.....	4	Heating/Reset	15
2.1. Main Features.....	4	Standby.....	15
2.2. Differences Between The Pump Types.....	4	Rotation Speed Setting Operations	
3. Installation.....	5	Via Input PWM	16
3.1. Preparations For Installation.....	5	Switching Outputs.....	16
3.2. Installing The Pump, Connecting The		5. Monitoring Operations	16
High Vacuum Side.....	5	5.1. Operations Display Via LED.....	16
Fitting The Splinter Shield.....	5	5.2. Turbopump Temperature Monitoring.....	16
3.3. Connecting The Fore-Vacuum Side.....	6	6. What To Do In Case	
3.4. Connecting The Cooling Unit.....	6	Of Breakdowns?	17
3.5. Connecting The Venting Valve.....	7	7. Service.....	18
3.6. Connecting The Heating Unit.....	7	8. Maintenance	19
3.7. Connecting The Electronic Drive Unit TC 600.....	8	8.1. Replacing The Lubricant.....	19
3.8. Installing The Power Pack Unit	8	8.2. Cleaning Strainer And Floater.....	19
3.9. Connecting The Sealing Gas Valve	8	8.3. Cleaning And Changing	
3.10. Connecting The Remote Control Unit	9	The Bearing On The Lubricant Pump.....	19
3.11. Connecting The Serial Interface RS 485	10	9. Technical Data.....	21
Connection	10	9.1. Dimensions Diagram	22
Connecting The RS 485	10	10. Spare Parts.....	22
3.12. Connections Diagram.....	11	11. Accessories	24
Connections Diagram		11.1. Lubricant.....	25
For 3-phase Backing Pump	12	Declaration of Contamination.....	26
4. Operations.....	13	Manufacturer's Declaration.....(last page)	
4.1. Filling In The Lubricant.....	13		
4.2. Before Switching ON.....	13		
4.3. Switching ON.....	13		
4.4. Circulatory Lubrication.....	14		
4.5. Heating.....	14		
4.6. Switching OFF And Venting.....	14		
4.7. Gas Type Dependent Operations	14		
4.8. Shutting Down For Longer Periods	14		
4.9. Operations With The DCU 001 / DCU 600	15		

Please note: Current operating instructions are available via www.pfeiffer-vacuum.de/Infoservice.

1. Safety Instructions

- ☞ Read and follow all instructions in this manual.
- ☞ Inform yourself regarding:
 - Hazards which can be caused by the pump;
 - Hazards which can be caused by your system.
 - Hazards which can be caused by the media being pumped.
- ☞ Avoid exposing any part of the body to vacuum.
- ☞ Observe the safety and accident prevention regulations.
- ☞ Regularly check that all accident prevention measures are being complied with.
- ☞ Do not operate the turbopump with open high vacuum flange.
- ☞ Do not carry out any unauthorised conversions or alterations to the turbopump with TC 600.
- ☞ When returning the turbopump observe the shipping instructions.
- ☞ Use at least 6 bracket screws to connect the high vacuum flange (ISO-flange).
- ☞ The turbopump must be anchored in accordance with the installation instructions.
- ☞ Do not disconnect the plug between the TC 600 and accessory components during operations.
- ☞ When the turbopump is open disconnect the voltage supply to the TC 600.
- ☞ When working on the turbopump, the high vacuum flange should only be opened once the rotor is at rest.
- ☞ When using sealing gas, the pressure in the hose connection should be limited to 2 bar via the overpressure valve.
- ☞ If a heater is in use high temperatures can arise of the turbopump. Take care to avoid burns.
- ☞ Keep leads and cables well away from hot surfaces (> 70 °C).
- ☞ Operate the turbopump with TC 600 only in conjunction with the relevant Power Pack Unit (accessory).
- ☞ The unit has been accredited protection class IP 30. When the unit is operated in environments which require other protection classes, the necessary measures must be taken.
- ☞ The mains connection must be subject to a safe connection to the PE (protection class 1).
- ☞ If the turbopump and the TC 600 are operated separately (only permissible with the agreement of the manufacturer) the turbopump must be connected to the PE.
- ☞ The cause of any operating voltage leakage to earth (red LED flashes) must be eliminated to avoid the danger of an electric shock.

Modifications reserved.

1.1. For Your Orientation

Instruction in the text

➔ Working instruction: here, you have to do something.

Symbols used

The following symbols are used throughout in illustrations:

- ⊕ High vacuum flange
- ⊖ Fore-vacuum flange
- ⚡ Electric connection
- ⊕ Sealing gas connection
- ⊖ Venting connection
- ⊖ Cooling water connection
- ⊕ Measuring connection

Abbreviations used

DCU = Operating and display control unit

TC = Electronic drive unit, turbopump

TPS = Power pack unit

Position numbers

The same pump and accessory parts have the same position numbers in all illustrations.

1.2. Pictogram Definitions



Danger of burns from touching hot parts.



Danger of an electric shock.



Danger of personal injury.



Danger of damage to the pump or to the system.



Danger of injury from rotating parts.

2. Understanding The Pumps TPH/TPU 2201

2.1. Main Features

Turbopumps TPH/TPU 2201 with the TC 600 form a complete unit. Voltage is supplied by Power Pack Unit (see "Accessories").

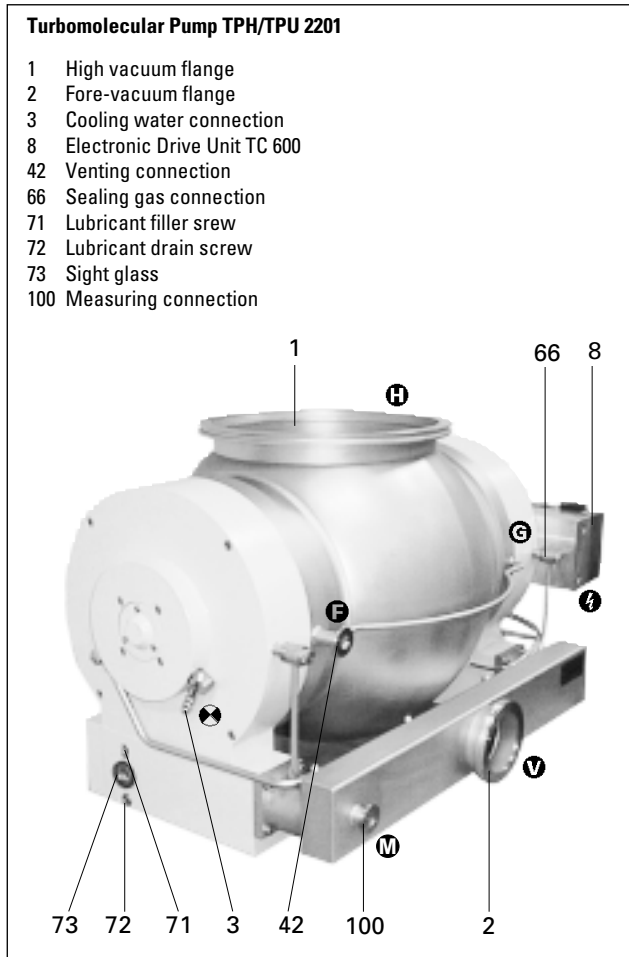

Cooling

Standard: Water cooling
 Integrated protective measures against excess temperatures:
 The Electronic Drive Unit TC 600 reduces the rotor rotation speed.

Bearings

The pump rotor has bearings at both ends. Each ball bearing has its own circulatory lubrication system.



The turbopumps must **not** be transported when filled with lubricant.

Proper use

- The Turbomolecular Pumps TPH/TPU 2201 may only be used for the purpose of generating vacuum.
- The turbopumps may only be used to pump those media against which they are chemically resistant. For other media the operator is required to qualify the pumps for the processes involved.
- If the process produces dust, the maintenance intervals must be specified accordingly and sealing gas must be used.
- If the pump is to be operated with more than 50% of the permissible gas load, sealing gas must be used.
- The turbopump must be connected to a backing pump in accordance with Section 3.3.
- Only PFEIFFER power pack units may be used to operate the TC 600. These power pack units guarantee voltage which is safely separated from the mains accordance with Standard EN 60 742. The use of other power pack units requires the express agreement of the manufacturer.
- The pumps may only be operated providing the ambient conditions in compliance with Protection Type IP 30 are observed.

Improper use

The following is regarded, inter alia, as improper:

- The pumping of explosive gases.
- Operating the pumps in areas where there is a danger of explosion.
- The pumping of gases and vapours which attack the materials of the pumps.
- The pumping of corrosive gases without sealing gas.
- The pumping of condensating vapours.
- Operations involving impermissibly high levels of gas loads.
- Operations with impermissibly high fore-vacuum pressure.
- Operations with improper gas modes.
- Operations involving too high levels of heat radiation power (see Section 9. "Technical Data").
- Operating the pump in environments which require a protection class superior to IP 30.
- The use of other power pack units or accessories which are not named in this manual or which have not been agreed by the manufacturer.
- The connection to power pack units with earthing of a direct voltage pole.

Improper use will cause all claims for liability and guarantees to be forfeited.

2.2. Differences Between The Pump Types

Feature	TPH 2201	TPU 2201
High vacuum flange	DN 250 ISO-K	DN 250 CF-F
High vacuum seal	Viton	Metal
Attainable final pressure	< 1 · 10 ⁻⁸ mbar (without baking-out)	< 1 · 10 ⁻¹⁰ mbar (with baking-out)

3. Installation

3.1. Preparations For Installation



Do not carry out any unauthorised conversions or alterations to the turbopump.

- The maximum permissible rotor temperature of the pump is 120 °C. If the vacuum chamber or parts in the vacuum chamber are heated, the values stated in the technical data relating to the level of heat which may be radiated into the pump must not be exceeded. If necessary, suitable shielding must be fitted in the vacuum chamber before the turbopump (constructional suggestions available on request).
- Only remove the blank flange from the high and for-vacuum side immediately before connection.
- The turbopumps must **not** be transported when filled with lubricant.
- Where magnetic fields of > 13.4 mT are involved suitable shielding must be provided (available on request).
- If the pump is baked out, the body of the pump must be insulated to prevent burns from accidental contact.
- Both the TPH and TPU 2201 must be anchored to the surface.
- In the event of a sudden standstill of the rotor, torques of up to 8960 Nm can arise and these must be taken up by the turbopump and frame. Pumps must be anchored as follows:
 - ISO flange with 6 bracket screws,
or
 - CF flange with the complete set of M8 screws,
or
 - underside of the pump with 6 screws M6,
screws quality 8.8.

3.2. Installing The Pump, Connecting The High Vacuum Side

Important

The utmost cleanliness must be observed when fitting all high vacuum parts. Unclean components prolong the pumping time.

Use a splinter shield

The use of a splinter shield in the high vacuum flange protects the turbopump against foreign bodies coming from the vacuum chamber but does reduce the volume flow rate of the pump by approximately 15%. For fitting splinter shields please refer to "Fitting the splinter shield".

The high vacuum side can be flanged onto the vacuum chamber either directly or via a bellows or a vibration compensator (see "Accessories").

Connecting via bellows

If the high vacuum side is to be flanged via a bellows, the turbopump must be secured for example via the holes on the underside of the turbopump (please see dimensions). The fastening must be able to withstand the torque referred to in Section 3.1.

Connecting Via A Vibration Compensator



The maximum permissible temperature at the vibration compensator is 100 °C.

Where a vibration compensator is in use, a freely suspended turbopump can be flanged onto the vacuum chamber. Additional protective casing must be provided to take up the energy of the rotor in the event of a malfunction (please discuss this question with the manufacturer).



The maximum loading capacity of the high vacuum flange is 3000 N (equivalent to 300 kg). This does not apply to pumps with flanges on the side or below. Asymmetric loading on the high vacuum flange must be avoided.

If a vacuum chamber is fitted to the high vacuum flange without support, it must be ensured that no torque is transmitted to the flange (asymmetrical weight of the vacuum chamber).

Even with side and under flanges, pumps can be flanged to the vacuum chamber with a freely suspended horizontal rotor shaft. It is a pre-condition that the vacuum chamber be firmly anchored.



No forces from the piping system must be allowed to act on the pump where turbopumps are anchored. Suspend or support all pipes to the pump.

Fitting The Splinter Shield

- ➔ Insert the splinter shield in the ISO-K flange in condition on delivery.

Inserting the splinter shield in ISO-K flange

A Strap (Condition on delivery)

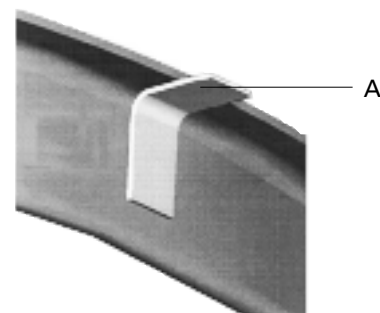

- ➔ Before insert the splinter shield in the CF-F flange the strap **must** be bent.

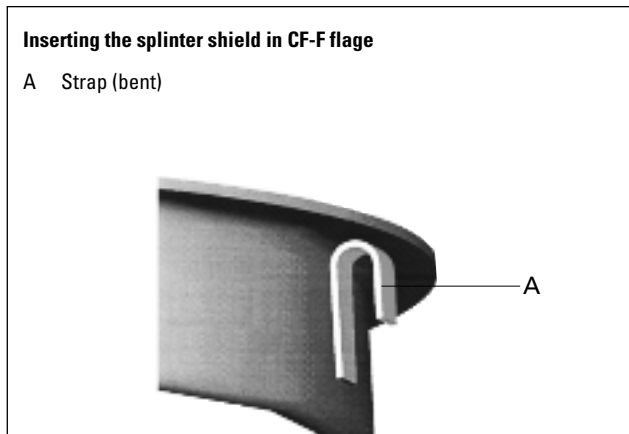

3.3. Connecting The Fore-Vacuum Side

- Backing pump: Fore-vacuum pressure ≤ 0.1 mbar
 Recommendation: Rotary Vane Vacuum Pumps from the PFEIFFER range.
 Where large volumes of gas are involved, we recommend a backing pump combination of rotary vane vacuum pump and roots vacuum pump.

Connecting the backing pump

All connections of the fore-vacuum line: With the usual small flange or clamping flange components.



Be sure to conduct away the exhaust gases from the backing pump. Do not reduce the free cross section of the fore-vacuum flange with following components.



The exhausted process gases and vapours can represent a health hazard and can also be environmentally damaging. Comply with all the gas manufacture's safety instructions.

- ➔ With rigid pipe connections: Fit a bellows in the connecting line to reduce vibration.
- ➔ The electrical connection of the backing pump is made via a relay box (Accessory) whose control line is connected to "FV PUMP" on the TC 600.

Please refer to Operating Instructions PM 800 544 BN for details on the relay box (1 phase backing pump and its installation).

Please refer to Section 3.12. for electrical connection of the 3 phase backing pump

3.4. Connecting The Cooling Unit

The Turbopumps TPH/TPU 2201 have been designed to be water cooled.

- The cooling water can be drawn either
- from the cooling water mains, or
 - from Recycled Water Cooling Unit TZK in closed circuit.

Cooling from the cooling water mains

To prevent deposits collecting in the pump the cooling water must be filtered.

Minimum cooling water requirements:

Mechanically clean, optically clear, no turbidity, no sediment, chemically neutral, temperature $>$ dew point.

Oxygen content:	max. 4 mg/kg
Chloride content:	max. 100 mg/kg
Carbonate hardness:	max. 10 ° dH
Consumption of potassium permanganate:	max. 10 mg/kg
Carbon dioxide:	Undetectable
Ammonia:	Undetectable
pH-value:	7 – 9
Max. fore-line over pressure:	max. 6 bar
Minimum flow rate at gas load max.:	100 l/h at 15 °C

Connection to the cooling water mains

- ➔ Fit the dirt trap (Accessory) in the supply line.
- ➔ Connect the supply line with hose clips onto one of the two cooling water connections.
- ➔ Connect the return line to the other cooling water connection of the turbopump.
- ➔ Tighten all hose clips and check for firm seating of the hoses.
- ➔ Tighten the hollow screws on the cooling water connection to a torque of 20 Nm.

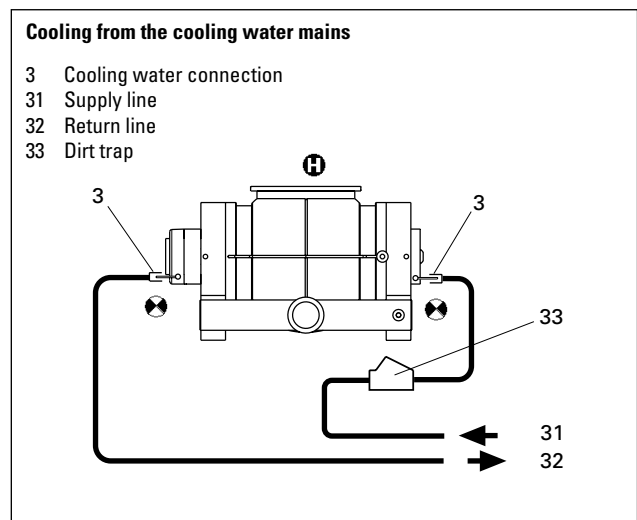

Cooling With The Recycled Water Cooling Unit TZK (Accessory)

Dirt traps are not permissible in the lines.
All other steps as for connecting to the cooling water mains.

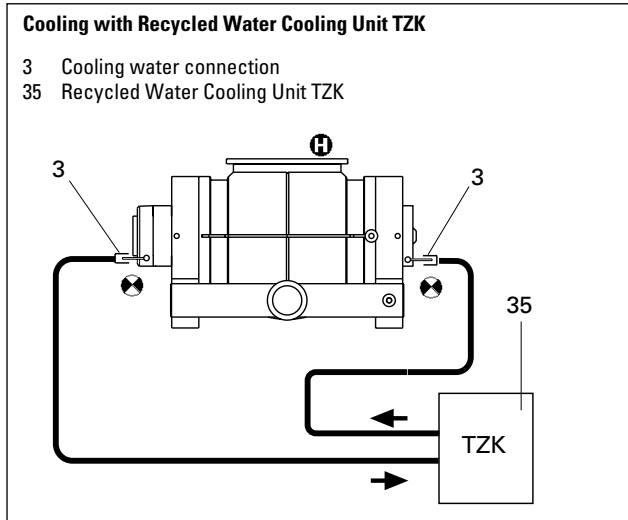

3.5. Connecting The Venting Valve

The venting valve (Accessory) provides automatic venting in the event of a power failure and switching off.

Fitting the venting valve

- ➔ Screw in venting valve with seal (USIT ring) on hexagonal SW 14.

Electrical connection

- ➔ Plug control lead 42a into the connection "VENT" of the TC 600 (8) on the turbopump.

The venting mode of the venting valve is selected via the DCU or Serial Interface RS 485.

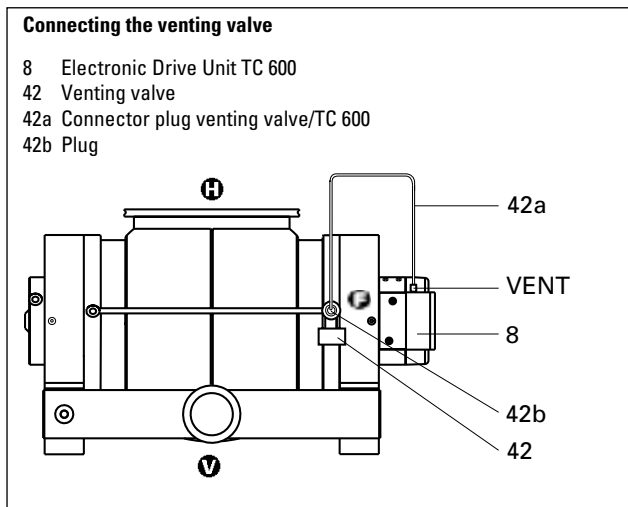

CAUTION The maximum pressure at the venting valve is 1.5 bar absolute.

Please refer to Operating Instructions PM 800 507 BN for details on Venting Valve TVV 005.

3.6. Connecting The Heating Unit



High temperatures are generated when turbopump or vacuum chamber are baked out. Contact with hot parts can cause burns, even when the heating has been switched off. Pump casing should be insulated when fitting. Do not touch pump casing during baking out.

- ➔ Lay heating round the pump body and fasten beside on the claps to the high vacuum flange.
- ➔ Plug control lead 46a into the connection "HEAT/TMS" of the TC 600 (8) on the turbopump.
- ➔ Connect mains cable 46c to the mains voltage.
Caution! Ensure correct mains voltage range.



The electrical connections must be carried out by qualified personnel in compliance with local regulations. The mains plug may only be connected to the mains voltage after the casing heating unit has been fitted to the turbopump.

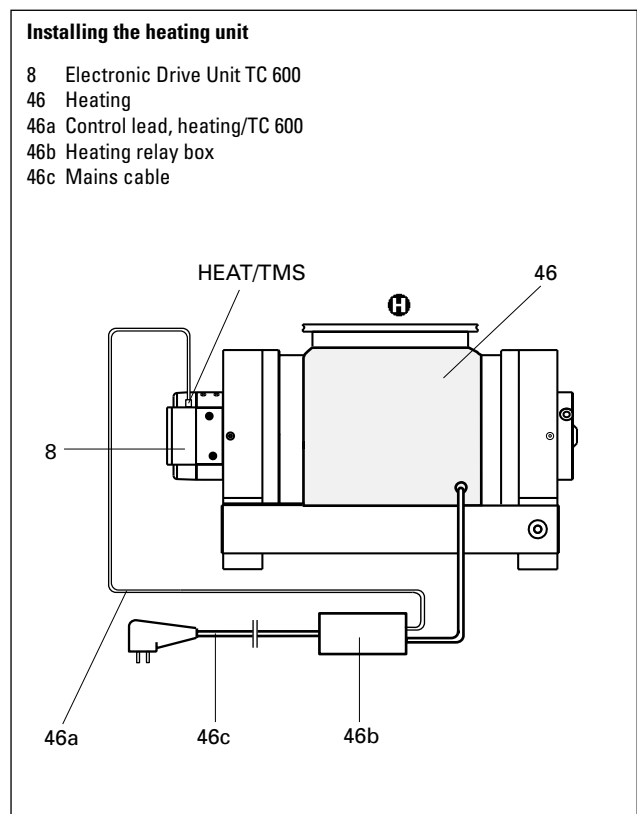

3.7. Connecting The Electronic Drive Unit TC 600

Please note:

The turbopump and the Electronic Drive Unit TC 600 are connected and together form a single unit.

Connecting cable 8a has to be ordered separately (see "Accessories").

- ➔ Connect plug X4 on connecting cable 8a with connection X4 on the TC 600 and secure with screw 8b.
- ➔ Connect plug X2 on connecting cable 8a with Power Pack Unit TPS 600/DCU 600 ("Accessories") on connection X2.



Once operations voltage has been supplied, the TC 600 performs a self test on the supply voltage.

The supply voltage for the turbomolecularpumps is 140 VDC ± 5% in accordance with EN 60 742.

3.9. Connecting The Sealing Gas Valve

To protect the pump, particularly where corrosive or dust producing processes are involved, it is necessary to use sealing gas. Connection is made via the sealing gas valve (please see "Accessories").

Please refer to Section 9.1. "Dimensions Diagram" for the sealing gas connection.

Please refer to Operating Instructions PM 800 229 BN for details on installing the sealing gas valve and adjusting the sealing gas flow.

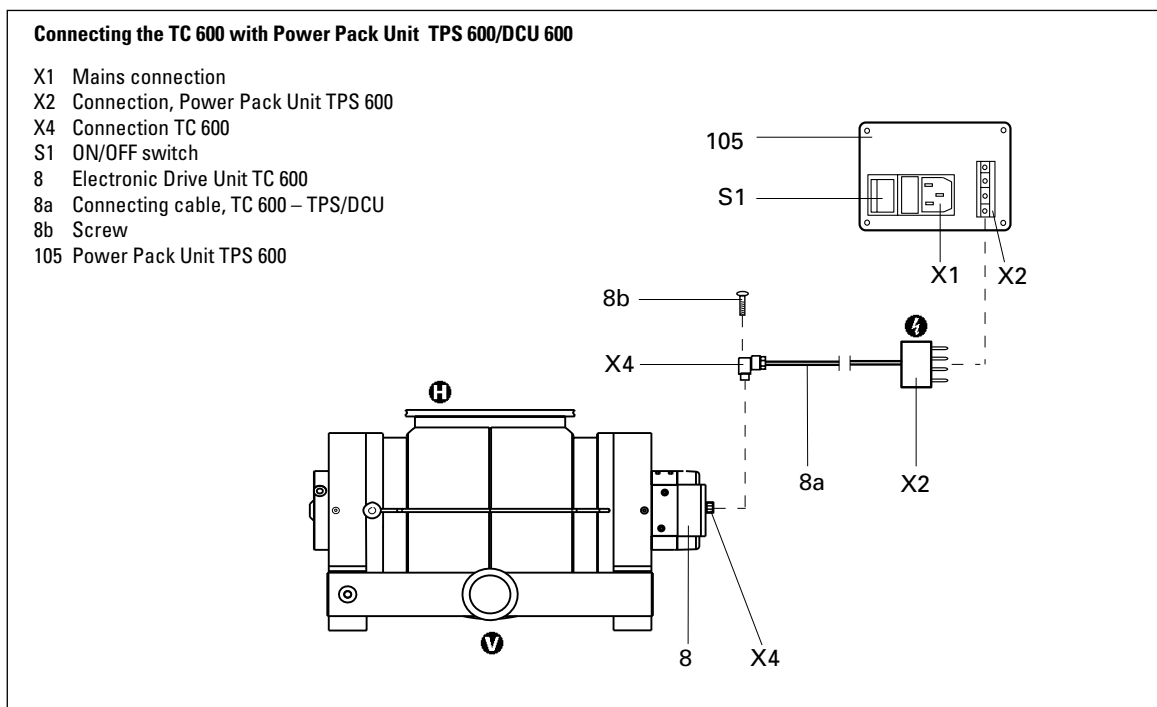

3.8. Installing The Power Pack Unit



Voltage may only be supplied with the PFEIFFER power pack units (Accessory). These power pack units guarantee voltage which is safely separated from the mains (in accordance with Standard

EN 60 742). The use of other power pack units requires the express agreement of the manufacturer.

Please note:

Operations with TPS 600/DCU 600 only possible in the connection voltage range 185-264 VAC.

Please refer to Operating Instructions PM 800 521 BN for details on Power Pack Unit TPS 600.

3.10. Connecting The Remote Control Unit

Remote control options for various functions are provided with the connection "REMOTE" on the TC 600 via the 10 pole screw connector plug (maximum cable cross section 0.14 - 1.5 mm²/connection).

Shielded cable should be used. Shielding has to be connected with the TC casing on the plug side of the TC 600 by using cable clamps.

The inputs 2 - 6 are activated by connecting them to the + 24V on pin 1 (active high) (please see Section 3.12. "Connections Diagram").

Pin Arrangement And Remote Plug Functions

(please see following table).



When connecting supply voltage, the turbopump is started.

On delivery:

Pin 1, Pin 2, Pin 3 and Pin 4 are bridged in the mating plug.

Pin arrangement and remote plug functions		
Pin Nr.	Input open (low)	Input closed (high) On + 24 V (pin 1)
1	+24 V	
2	venting blocked (see Section 3.5.)	venting release (see Section 3.5.)
3	motor, turbopump off	motor, turbopump on: the turbopump is driven, current flows through the motor coils.
4	pumping station off	pumping station on: the turbopump is driven, backing pump is activated.
5	heating off	heating on: the heating is switched on once the rotation speed switchpoint is attained and off when the rotation speed switchpoint is unattained.
5		Reset: by supplying a pulse (T < 2s) with an amplitude of 24V a malfunction acknowledgement can be processed.
6	standby off	standby on: pump is accelerated to 66% of its nominal rotation speed.
7	rotation speed setting mode off	the rotation speed can be changed by feeding a PWM signal to this pin or via Serial Interface RS 485 (see Section 4.10. "Rotation Speed Setting Mode")
8	Output (low) rotation speed switchpoint not attained	Output (high) set rotation speed switchpoint attained; output can be loaded with 24 V/50 mA
9	Output (low) collective malfunction message; output can be loaded with 24 V/50 mA	Output (high) malfunction-free operations
10	Mass (ground)	

3.11. Connecting The Serial Interface RS 485

An external operating component (DCU 001/DCU 600) or an external computer can be connected via the connection "RS 485" on the TC 600 with the use of an 8 pole modular connecting cable.

The serial interface is galvanically and safely separated from the maximum supply voltage from the TC 600.

Connection

Description	Value
Serial Interface Type:	RS 485
Baudrate:	9600 baud
data word lengths:	8 bit
Parity:	no (no parity)
Startbits:	1
Stopbits:	1..2

The electrical connections are internally optically decoupled.

PIN	Arrangement
1	not connected
2	+24V output (≤ 210 mA loading capacity)
3	not connected
4	not connected
5	RS 485: D+ (DO / RI)
6	Gnd — —
7	RS 485: D- (DO / RI)
8	not connected

Please note:

It is possible to connect an RS 232 (e.g. PC) via a level converter (please see "Accessories").

RS 485



1 ... 8

(View from the plug side of the TC 600)

Connecting The RS 485

Connecting to a fixed bus system:

- ➔ Connect all units with D+ (pin 5/RS 485) and D- (pin7/RS 485) to the bus.
- ➔ The bus must be connected at both ends.

The connections should be made in accordance with the specification of the Serial Interface RS 485.

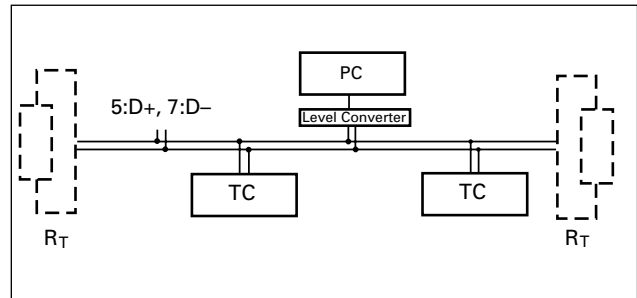

All units connected to the bus must have differing serial interface addresses (parameter 797).

The group address of the TC 600 is 960.



Only safety low voltages (SELV) may be connected to Serial Interface RS 485 .

All switched on remote functions have priority over the serial interface functions.

Please Note:

Please refer to the separate Operating Instructions PM 800 488 BN for more detailed information on operations via Serial Interface RS 485 and its electronic data.

3.12. Connections Diagram

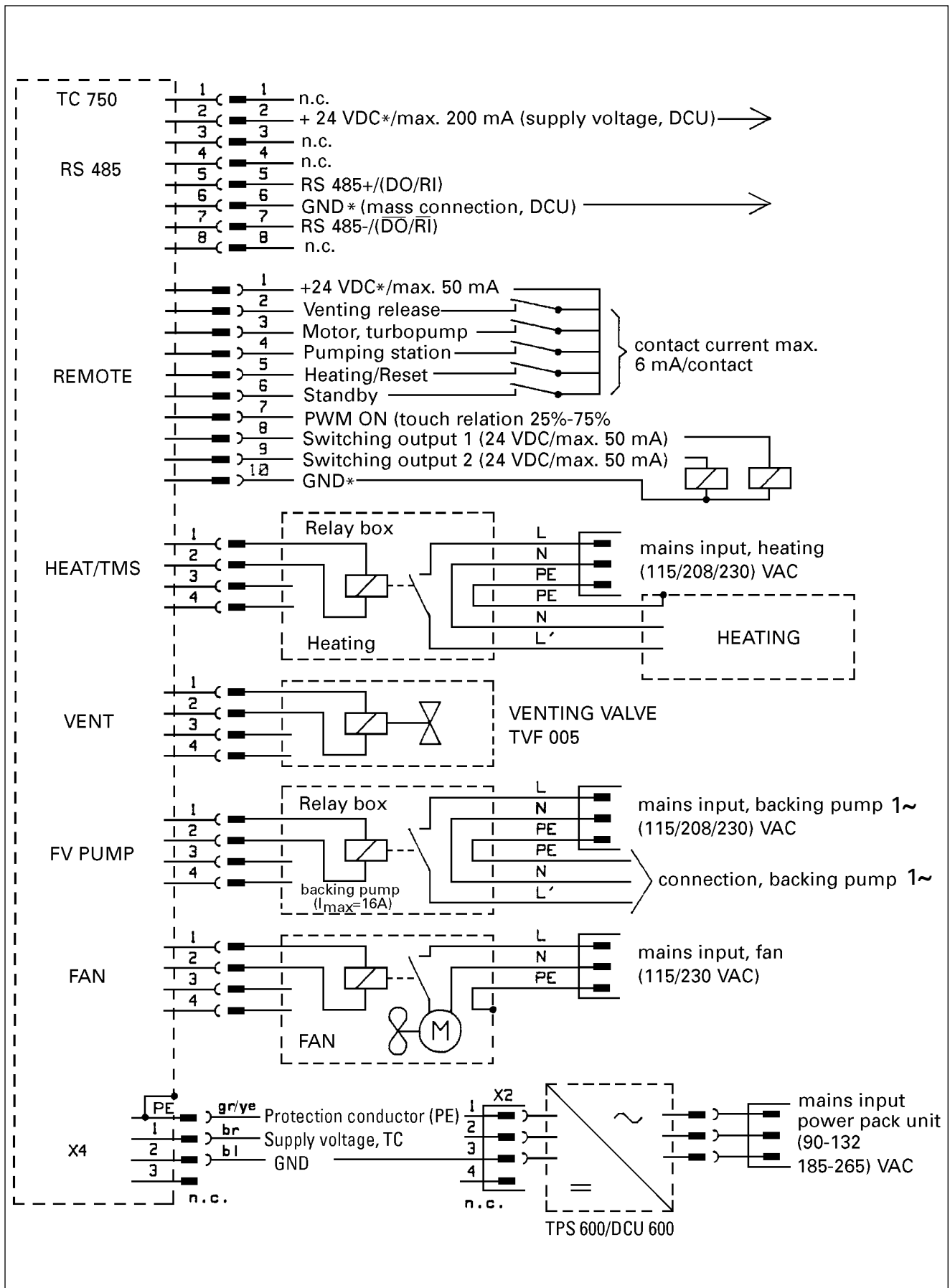

Connection Diagram For 3-phase Backing Pump

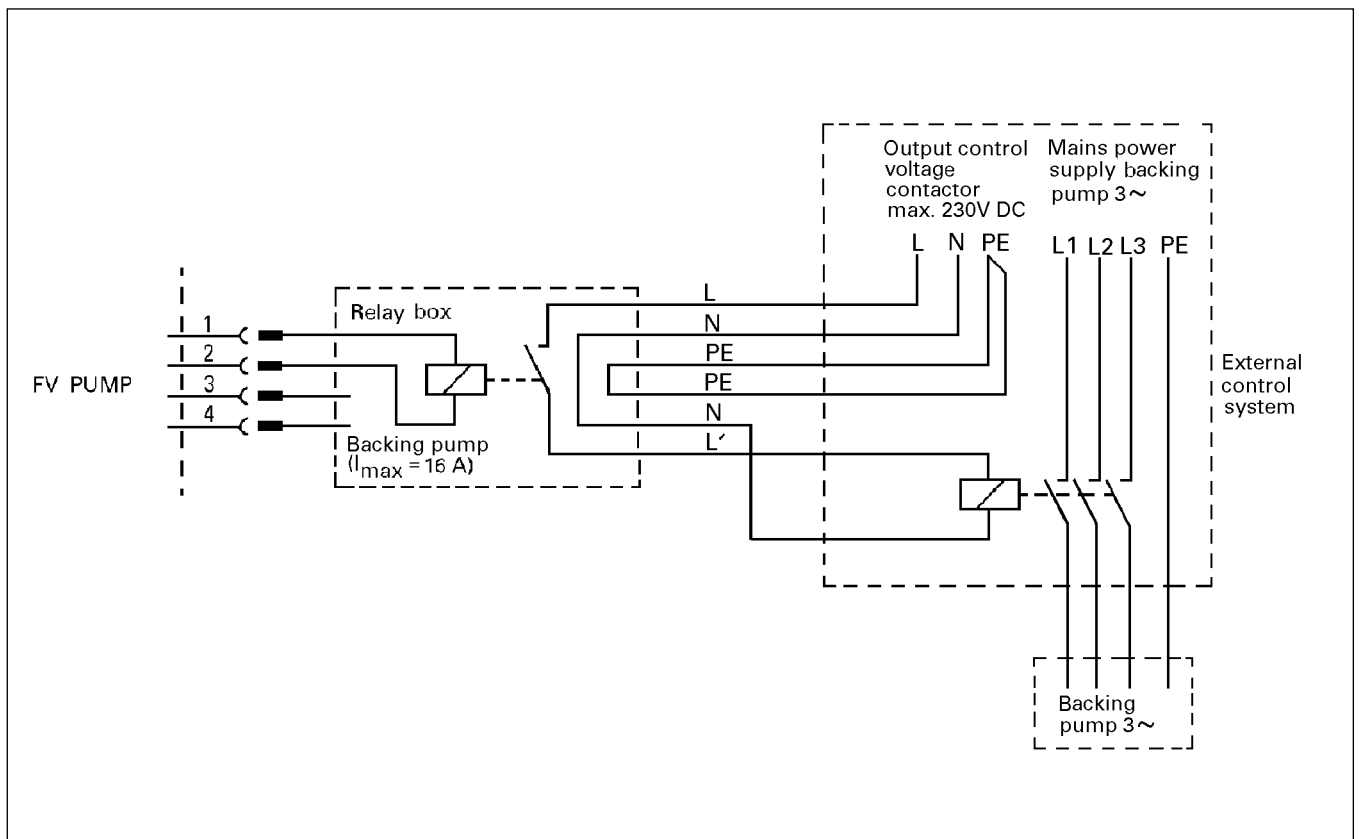

4. Operations

4.1. Filling In The Lubricant



Pumps must be filled with lubricant before being operated.

If possible fill in the lubricant in the fitting position of the pump.

The pumps must **not** be transported when filled with lubricant.

Pumps are designed to operate with Lubricant "TL 011" or "F3" (see rating plate).

For pumps which have been designed to operate with "TL 011" a pack of "TL 011" is supplied with the pump. For pumps which have been designed to operate with "F3", no lubricant is supplied with the pump. The lubricant must be ordered separately (see Section 11.1.).



If "F3" is heated above 300 °C, toxic vapours which can harm the airways are given off. Do not allow "F3" to come into contact with tobacco products (danger of poisoning when ignited). The precautions necessary in the handling of chemicals must be observed.



Pumps designed to operate with "TL 011" must not be modified to operate with "F3" and vice versa.

Filling in the lubricant

- ➔ Unscrew lubricant filler screw and, using the syringe provided, inject approximately 125 cm³ lubricant into each lubricant chambers.
- ➔ The sight glass should be filled approximately in the middle with lubricant
- ➔ Screw back in lubricant filler screw with the O-ring.

4.2. Before Switching ON

Sections 4.2 to 4.6. refer only to operating the pump in its condition on delivery, without the DCU operating unit. The bridges "venting release", "motor, TMP ON" and "pumping station ON" are fitted in the remote control plug.



Turbopump rotors rotate at high speed. When the high vacuum flange is open there is a danger of injury and of damage to the pump caused by objects falling into the pump.

Therefore never operate the pump with open high vacuum flange.

- ➔ With sealing gas: Open the sealing gas supply.
- ➔ Open cooling water supply and check flow.
- ➔ Plug connecting cable 8a ("Accessory") into the TC 600 and connect with Powe Pack Unit TPS 600 on X2 (please see Section 3.7.).

Please note:

The following pre-settings have been programmed:

- Start-up time 8 min
- Rotation speed switchpoint 80%
- Automatic venting 50%

These settings can only be altered via Serial Interface RS 485 (DCU or PC); please refer to the respective operating instructions.

4.3. Switching ON

- ➔ Switch on the turbopump with switch S1 on the power pack unit.
- Once the self test has been successfully completed on the TC 600 (duration approximately 20 seconds), both the turbopump and the backing pump (if connected) begin operating.
- With air cooling the cooling fan is also switched on via Electronic Drive Unit TC 600.

Rear panel, TPS 600

- S1 ON/OFF switch
- X1 Mains connection
- X2 Connection TC 600
- F1 Fuse
- F2 Fuse

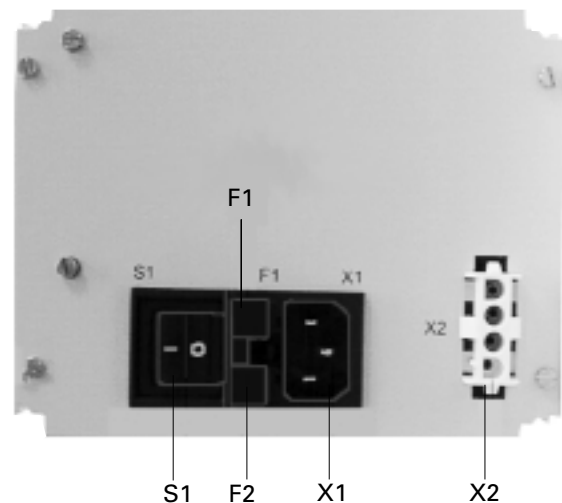

Please note:

When the unit is switched on for the first time or after a lubricant change the contact to the lubricating pump can open as a result of the degassification of the lubricant. In such cases, as for other malfunctions, the electronic drive unit shuts down the turbopump.

- ➔ The turbopump must be re-started with switch S1 on the power pack unit.



Take care when pumping hazardous gases and observe the safety precautions of the gas manufacturer.

4.4. Circulatory Lubrication

The ball bearing on the fore-vacuum side is supplied with lubricant via the lubricating pump.

The circulation of the lubricant is monitored via a switching contact. If there is insufficient lubricant, the electronic drive unit switches off the turbopump. Monitoring is active only from 60% of the final rotation speed.

If, at a rotation speed of > 60% of the final rotation speed (for example through the degassification of the lubricant), the contact opens for ≥ 2 minutes, the electronic drive unit assumes a lubricant deficiency and switches off the turbopump.

- ➔ Check the filling level of the lubricant.
- ➔ Re-start the turbopump with switch S1 on the power pack unit.

4.5. Heating

Heating turbopumps and vacuum chambers accelerates the attainment of final pressures.

The heating period is dependent on the level of contamination and the required final pressure. Heat for at least four hours.

4.6. Switching OFF And Venting

To avoid contamination occurring when switching off, the pump should be vented before shut-down.

- ➔ Switch off both turbopump and backing pump on the power pack unit at the same time with switch S1.
- ➔ With the Venting Valve TVF 005 the turbopump is vented automatically.
- ➔ Shut off water supply.

4.7. Gas Type Dependent Operations



Water cooling is required if the pumps are to be operated with gas load.

Where high level gas loads and rotation speeds are involved, the resulting friction subjects the rotor to the effect of great heat. To avoid over-heating, a power rotation speed characteristic line is implemented in the TC 600; this ensures that where maximum gas loads are involved, the pump will operate at any rotation speed without the danger of damage arising.

The maximum power is dependent on the type of gas. Two characteristic lines are available for any type of gas in order to fully exploit the power potential of the pump:

- "Gas-Mode 0" for gases with molecular mass ≥ 40 as, for example, Argon;
 - "Gas-Mode 1" for all lighter gases.
- ➔ Set the applicable gas mode with the DCU 001 or DCU 100 (please refer to Operating Instructions "Pumping operations with the DCU" PM 800 547 BN).



Pumping gases with molecular mass ≥ 40 with the incorrect gas mode can cause damage to the pump.

For the vertex of the power characteristic line please refer to Section 8. Technical Data.

Maximum power is applied when the pump starts in order to limit the time required. Once the set rotation speed is attained, switching to the selected power characteristic line is automatic.

If the gas dependent maximum power is exceeded, the rotation speed is reduced until equilibrium between the permissible power and gas friction is attained. The power limitation serves to protect the pump against thermal overloading. In order to avoid rotation speed fluctuations it is recommended to set, in rotation speed setting mode, the equilibrium frequency or a somewhat lower frequency.

Please note:

There can be types of pump whereby there is no differentiation between the two "gas modes" settings.

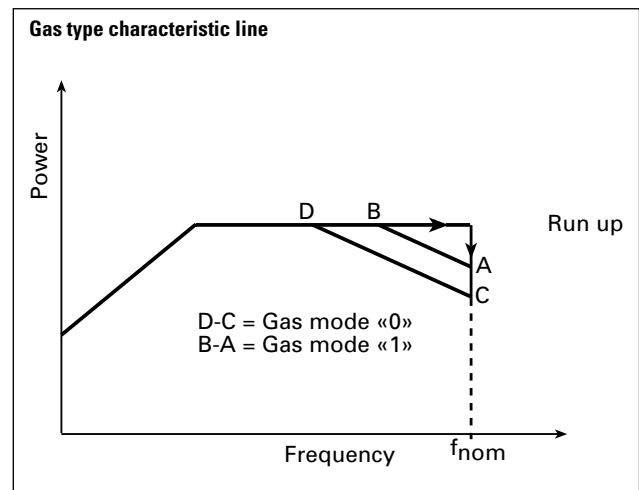

4.8. Shutting Down For Longer Periods



Vacuum pumps are sometimes used to pump aggressive or hazardous gases. There is a danger of personal injury resulting from coming into contact with process gases. Before removing a turbopump from the system, first:

- Vent the turbopump with a neutral gas or dry air.
- Ensure that there is no residual process gas in the system nor in the feeder lines.

If the turbopump is to be shut down for more than a year:

- ➔ Remove turbopump from the system.
 - ➔ Change the lubricant (see Section 8.1.).
- Please note:** Lubricant TL 011 must no longer be used after **2 years** of non-operations.
- ➔ Close the high vacuum flange and evacuate the turbopump via the fore-vacuum flange.
 - ➔ Vent turbopump via the venting connection with nitrogen or dry air.

- ➔ Close fore-vacuum and venting connection by blank flanging.
- ➔ In rooms with moist or aggressive atmospheres, the turbopump must be air-sealed in a plastic bag together with a bag of dessicant, e.g silicagel.

Important:

If the pump has been shut down for **3 years** a bearing change must be carried out (please get in touch with PFEIFFER Service).

4.9. Operations With The DCU 001 / DCU 600

Operations with the DCU 001 or DCU 600 should be carried out in accordance with the relevant Operating Instructions PM 800 477 BN (DCU description) and PM 800 547 BN (operating the pump with the DCU).

4.10. Operations With The Remote Control Unit

(please refer to the table in Section 3.10.).

Remote control operations can be performed via the connection with the designation "REMOTE" on the TC 600.

The connection is via a 10 pole screwed connector plug with the following arrangement:

- 1- + 24V
 - 2 - Input, venting
 - 3 - Input, turbopump motor
 - 4 - Input, pumping station
 - 5 - Input, heating unit
 - 6 - Input, Standby
 - 7 - Input, PWM
 - 8 - Switching output 1: Rotation speed switchpoint
 - 9 - Switching output 2: Collective malfunction message
 - 10 - Mass
- Inputs 2-6 are activated if they are connected with the +24 V on pin 1 (active high).



On delivery there is a bridge between Pin 1, Pin 2, Pin 3 and Pin 4 on the TC 600 mating plug.

When operations voltage is supplied and a successfully completed

TC 600 self-test the turbopump and any connected backing pump will be started.

Venting Release (Optional)

Automatic venting:

When the turbopump or pumping station is switched off the venting valve opens for the venting time of 3600 seconds (1 hour) when the venting frequency falls below 50% of the final rotation speed (330 Hz). In the event of a mains power failure if the venting frequency falls below 50% of the final rotation speed the venting valve opens and closes on attainment of 15% of the final rotation speed.

Venting OFF:

Venting does not take place.

Other venting modes:

Other venting modes can be selected via the DCU.

Motor, Turbopump

When the pumping station is switched on and once the self test has been successfully completed (duration approximately 20 seconds), the turbopump is set in operation.

During operations, the turbopump can be switched on and off while the pumping station is switched on.

Pumping Station

Any connected pumping station components are started up (e.g. backing pump, venting valve, air cooling) and with simultaneous activation of the input "motor, turbopump" the turbopump is set in operation once the self test has been successfully completed (duration approximately 20 seconds).

Heating/Reset

Heating (optional)

Once the rotation speed switchpoint is attained the heating unit is switched on; when the rotation speed switchpoint is fallen below the heating unit is switched off.

Reset

The heating input has two functions (please see Section 3.10., point 5 "Reset").

Standby

The pump can be operated optionally at 66% of its nominal rotation speed (standby ON) or at its nominal rotation speed (standby OFF).

Rotation Speed Setting Operations Via Input PWM

The supply of pulse width modulated signals (PWM) with a ground frequency of 100 Hz $\pm 20\%$ with an amplitude of maximum 24 V and a touch ratio of 25-75% enables the rotation speed to be set in the range from 20-100% of the nominal rotation speed.

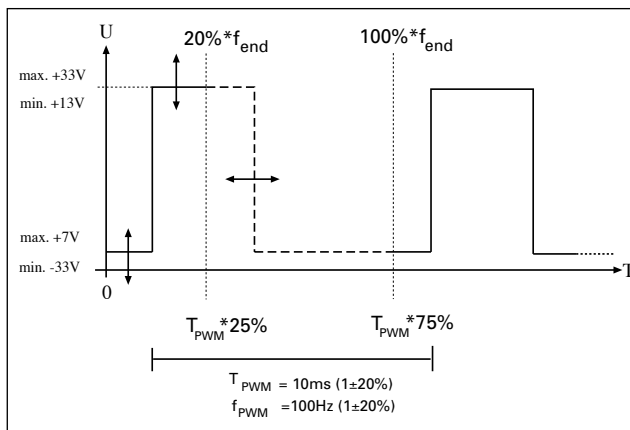

If no signal is present the pump runs up to its final rotation speed.

A PWM adapter box for rotation speed setting operations for the turbopump is available as an option (please see "Accessories").

Switching Outputs

Switching outputs 1 and 2 can be loaded with a maximum 24 V / 50 mA per output. The following functions are assigned to the switching outputs:

Switching output 1: Active high when the rotation speed switchpoint is attained. The switchpoint for the turbopump is set at 80% of the nominal rotation speed. It can be used, for example, for a message "pump ready to operate".

Switching output 2: Active low with a malfunction - collective malfunction message

The connection of a relay is made between pin 10 (mass) and the respective switching output pin 8 or pin 9 (see Section 3.12. Connections Diagram).

5. Monitoring Operations

5.1. Operations Display Via LED

Certain operations modes of the turbopump and the TC 600 can be ascertained via the two integrated LEDs located on the front panel of the TC 600.

The following operations modes are displayed:

LED		Cause
I	L	
glows green		<ul style="list-style-type: none"> Power pack unit OK Function "pumping station ON" carried out
flashes green		<ul style="list-style-type: none"> Power pack unit OK Pumping station OFF
blinks green		<ul style="list-style-type: none"> Mains power supply failure
	glows red	<ul style="list-style-type: none"> Collective malfunction (for example, start-up time error, excess temperature, turbopump or TC 600, lubricant deficiency) Switching output 2 active (low)
	blinks red	<ul style="list-style-type: none"> Warning (for example, earth leakage fault in the voltage supply, mains power supply failure)

Please note:

Differentiated malfunction and warning signals are only possible with the use of the DCU.

5.2. Turbopump Temperature Monitoring

Where impermissible motor temperatures are involved or the temperature of the TC 600 casing is too high, the motor current is reduced. This can lead to dipping below the set rotation speed switchpoint and results in the turbomolecular pump being switched off.

LED on the TC 600 glows red: Collective malfunction.

6. What To Do In Case Of Breakdowns?

Problem	Possible Causes	Remedy
Pump doesn't start; None of the integrated LEDs glow on the TC 600	<ul style="list-style-type: none"> • Power supply interrupted • Incorrect operations voltage supplied • Pins 1-3 and 1- 4 on the remote-plug not connected • No supply of operations voltage • Defect TC 600 • Reduction in the voltage in the cable 	<ul style="list-style-type: none"> • Check fuse in the power pack unit • Check plug contacts on the power pack unit • Check power pack unit feeder line • Check voltage on the power pack unit (140V DC) at connection X2 • Supply correct operations voltage • Connect pins 1-3 and 1- 4 on the remote plug • Check plug contacts on the power pack unit • Inform PFEIFFER Service of need for repair • Use suitable cable
Pump doesn't attain nominal rotation speed within the set - start-up time; Pump cuts out during operations	<ul style="list-style-type: none"> • Fore-vacuum pressure too high • Leak or too much gas • Rotor sluggish caused by defective bearing • TC start-up time too short • Thermal overloading caused by: <ul style="list-style-type: none"> – Insufficient water flow – Insufficient air supply – Fore-vacuum pressure too high – Ambient temperature too high • Leak or too high a gas load • Lubricant or lubricant pump dirty • Lubricant deficiency 	<ul style="list-style-type: none"> • Check backing pump function • Check seals • Seek leak and repair • Supply of process gas too high; reduce • Check bearing (noises?): Request PFEIFFER Service to replace • Set longer start-up time with the DCU or PC • Ensure free flow • Ensure adequate air supply • Reduce fore-vacuum pressure • Reduce ambient temperature • Seek leak in the system and repair • Process gas supply too high; reduce • Carry out lubricant change as per Section 8.1. or clean the lubricant pump as per Section 8.3. • Check lubricant and replace as necessary
Pump doesn't attain final pressure	<ul style="list-style-type: none"> • Pump dirty • Leak in vacuum chamber, lines or pump 	<ul style="list-style-type: none"> • Bake out pump • If seriously contaminated: Request PFEIFFER Service to clean • Seek leak starting with vacuum chamber • Repair leak
Unusual operating noises	<ul style="list-style-type: none"> • Bearing damaged • Rotor damaged • Splinter shield (if fitted) not seated firmly 	<ul style="list-style-type: none"> • Inform PFEIFFER Service of need for repair • Inform PFEIFFER Service of need for repair • Check seat of splinter shield (see Section 3.2.)
Red LED on the TC 600 glows	<ul style="list-style-type: none"> • Collective malfunction 	<ul style="list-style-type: none"> • Reset via mains OFF/ON or remote pin 5 • Different malfunction display with a DCU possible
Red LED on the TC 600 blinks	<ul style="list-style-type: none"> • Warning from: <ul style="list-style-type: none"> – Mains power failure – Supply voltage short circuit to earth 	<ul style="list-style-type: none"> • Different warning display with a DCU is possible • Ccheck power pack voltage • Check the power pack mains connection • Check the power pack unit voltage for short circuit to earth

7. Service

Do make use of our service facilities

In the event that repairs are necessary a number of options are available to you to ensure any system down time is kept to a minimum:

- Have the pump repaired on the spot by our PFEIFFER Service Engineers;
- Return the pump to the manufacturer for repairs;
- Replace the pump.

Local PFEIFFER representatives can provide full details.



Please take into account that where PFEIFFER Service replacement service is involved the standard operating parameters are always pre-set.

If your application requires different parameters, please modify accordingly.

Please note:

The turbopump and the Electronic Drive Unit TC form a single unit and must therefore be returned complete for repair purposes. Before returning the unit it should be ensured that the power pack unit is not the cause of the malfunction (please see Section 5. for checking the power pack unit).

Before returning:

- ➔ Please attach a clearly visible notice "Free of harmful substances" (both on the unit and also on the delivery note and any accompanying letters).

"Harmful substances" are substances and preparations as defined in the current, local, dangerous substances regulations; in the U.S.A. as "materials in accordance with the Code of Federal Regulations (CFR) 49 Part 173.240 Definition and Preparation". We will carry out the decontamination and invoice this work to you if you have not attached this note. This also applies where the operator does not have the facilities to carry out the decontamination work.

Fill out the declaration of contamination

- ➔ In every case the "Declaration of Contamination" must be completed diligently and truthfully.
- ➔ A copy of the completed declaration must accompany the unit; any additional copies must be sent to your local PFEIFFER Service Center.

Please get in touch with your local PFEIFFER representatives if there are any questions regarding contamination.



Decontaminate units before returning or possible disposal. Do not return any units which are microbiologically, explosively or radioactively contaminated.

Returning contaminated units

If contaminated have to be returned for maintenance/repair, the following instructions concerning shipping must be followed:

- ➔ Neutralise the pump by flushing with nitrogen or dry air.
- ➔ Seal all openings to the air.
- ➔ Seal pump or unit in suitable protective foil.
- ➔ Ship units only in appropriate transport containers.

Please note:

Repair orders are carried out according to our general conditions of sale and supply. If repairs are necessary, please send the pump to your nearest PFEIFFER Service Center.

Contact addresses and telephone hotline

Contact addresses and telephone numbers can be found on the back cover of these operating instructions.

8. Maintenance

Important

No liability for personal injury nor material damage will be accepted for damages and operational interruptions which have been caused by improper maintenance; in addition, all guarantees become invalid.

You can change the lubricant yourself. Your pump can be cleaned on the spot if it is not very dirty.
Your local PFEIFFER Service can advise you regarding cleaning procedures and any other maintenance and service work.



Ensure no mechanical forces act on the Electronic Drive Unit TC 600.

8.1. Replacing The Lubricant

The lubricant should be replaced, at the latest, after 5000 operating hours or at least once a year.

Where extreme operating conditions or unclean processes are involved, the replacement interval should be checked with your PFEIFFER Service Center.

- ➔ Switch off the turbopump, vent to atmospheric pressure (see Section 4.7.) and allow to cool as necessary.
- ➔ Unscrew lubricant drain screw 72 and drain lubricant out of both chambers into a suitable container.
- ➔ Screw back in lubricant drain screws with o-ring 75.
- ➔ Unscrew lubricant filler screws 71.
- ➔ Using the syringe provided inject approximately 125 cm³ of lubricant into each lubricant chambers as per the rating plate (please see Section 4.1. for the lubricant level).
- ➔ Screw in lubricant filler screws 71 with o-ring 75.



Lubricants can contain toxic substances from the medium pumped. Lubricant must be disposed of in accordance with the respective regulations.

Safety instructions data sheet on request.

8.2. Cleaning Strainer And Floater

The strainer 81 and the floater 79 must be cleaned in pure alcohol after every lubricant replace or after every 20,000 operating hours.



All legal requirements regarding the handling of solvents must be observed.

- ➔ Drain lubricant and dispose of as described in Section 8.1.
- ➔ Screw out screws 82 (4 pieces) and withdraw lubricant pump 77.
- ➔ Remove circlip 89.
- ➔ Pull off strainer 81 and clean.
- ➔ Screw off locking screw 80.
- ➔ Remove floater 79.
- ➔ Clean boring, sealing surface and floater.
- ➔ Re-assemble all parts in reverse order.
Check cleanliness and correct positioning of the o-rings; if necessary fit new once.

8.3. Cleaning And Changing The Bearing On The Lubricant Pump

Please note:

If one lubricant pump requires a bearing change, the other bearing should be changed at the same time.

- ➔ Drain lubricant and dispose of as described in Section 8.1.
- ➔ Remove fixtures of supply cable 83 on cooling water pipe.
- ➔ Screw out screws 82 (4 pieces) and draw out lubricant pump 77 from the housing in an axial direction; take care with o-ring 74 and 87.
- ➔ Remove circlip 89 and detach strainer 81 from bearing mounting 84.
- ➔ Unscrew screws 86 and detach bearing mounting 84.
- ➔ Remove pump shaft 78a from part 84.
- ➔ Remove both ball bearings 78 from pump shaft 78a.
- ➔ Unscrew locking screw 80; take care to o-ring 88.
- ➔ Remove floater 79 from the boring.
- ➔ Clean all parts in pure alcohol.
- ➔ Check strainer, ball bearings and o-rings for wear and tear and replace as necessary.
- ➔ Re-assemble lubricant pump in reverse order.
- ➔ Fill in lubricant in accordance with Section 8.1.

Lubricant pump

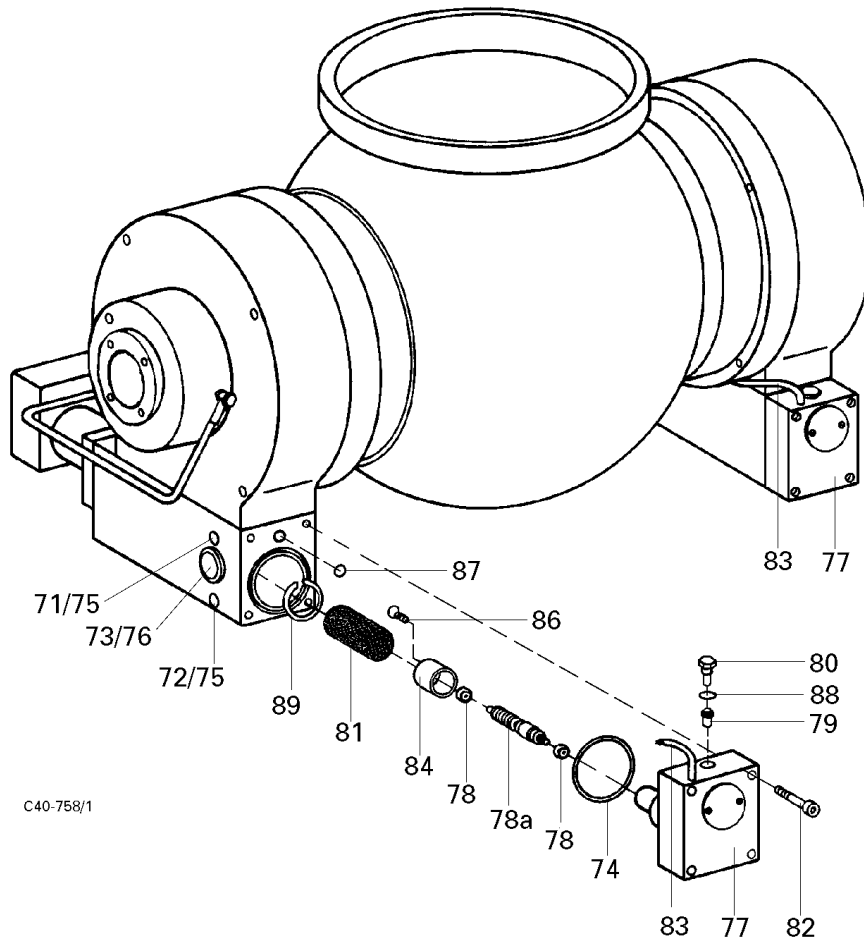

C40-758/1

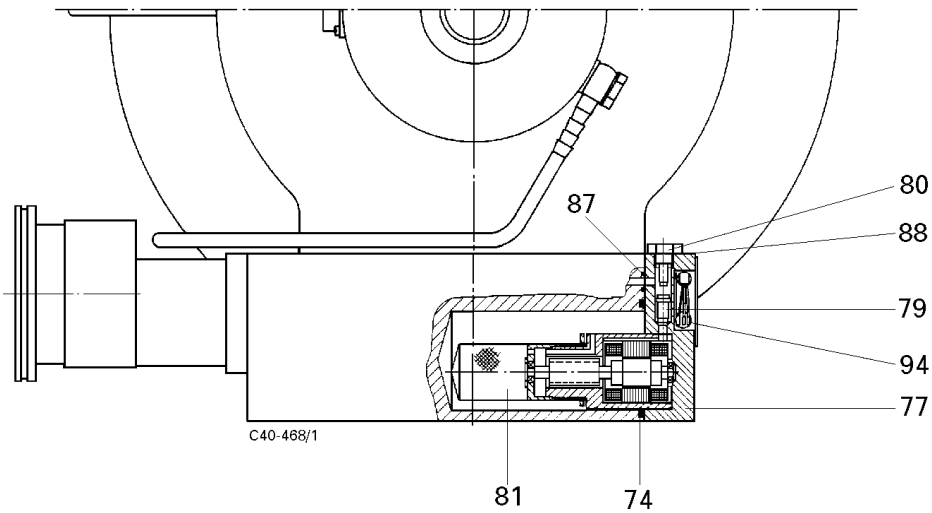

C40-468/1

- 71 Lubricant filler screw
- 72 Lubricant drain screw
- 73 Sight glass
- 74 O-ring
- 75 O-ring
- 76 O-ring
- 77 Lubricant pump
- 78 Ball bearing
- 78a Pump shaft
- 79 Floater

- 80 Locking screw
- 81 Strainer
- 82 Securing screw
- 83 Supply cable
- 84 Bearing mounting
- 86 Screw
- 87 O-ring
- 88 O-ring
- 89 Circlip
- 94 Switch

9. Technical Data

Feature	Unit	TPH 2201	TPH 2201
Connection nominal diameter Inlet Outlet Venting connection		DN 250 ISO-K DN 63 ISO-K G 1/8"	DN 250 CF-F
Nominal rotation speed	1/min		36 000
Standby rotation speed	1/min		24 000
Start-up time (up to 90% of the nominal rotation speed, fore-vacuum pressure $\leq 0,1$ mbar)	min		13
Noise level	dB (A)		59
Maximum permissible rotor temperature	°C		120
Permissible heat radiation power	W		30
Volume flow rate for: Nitrogen N ₂ Helium He Hydrogen H ₂	l/s		2100 2500 2000
Compression ratio for: N ₂ He H ₂			10 ⁸ 4 · 10 ⁴ 2 · 10 ³
Maximum fore-vacuum pressure N ₂ Argon (Ar)	mbar		0,25 0,23
Maximum gas throughput ¹⁾ with water cooling N ₂ Ar	mbar l/s		5,4 2,7
Vertex power characteristics lines ²⁾ A B C D	W / Hz		560 / 600 560 / 600 560 / 600 560 / 600
Final pressure ³⁾ with rotary vane vacuum pump	mbar		< 1 · 10 ⁻⁹
Lubricant Type ⁴⁾ Filling volume	cm ³		TL 011 oder F3 2 x 125
Cooling water consumption with water at 15 °C ⁵⁾ Cooling water temperature	l/h		40 5 - 25
Permissible magnetic field Power consumption heating unit Weight	mT W kg		13,4 400 79 84
Connection voltage Current consumption Power Protection class	VDC A W		140 ± 5% 4,3 600 IP 30

- 1) Measured with a rotary vane vacuum pump > 60 m³/h, higher gas throughputs with reduced rotation speed.
- 2) For gas type characteristics lines please refer to Section 4.7.
- 3) In accordance with DIN 28 428 the final pressure of a turbomolecular pump is that pressure which is attained in a measuring dome 48 hours after baking out.
- 4) See rating plate.
- 5) With maximum gas throughput up to 100 l/h.

9.1. Dimensions Diagram

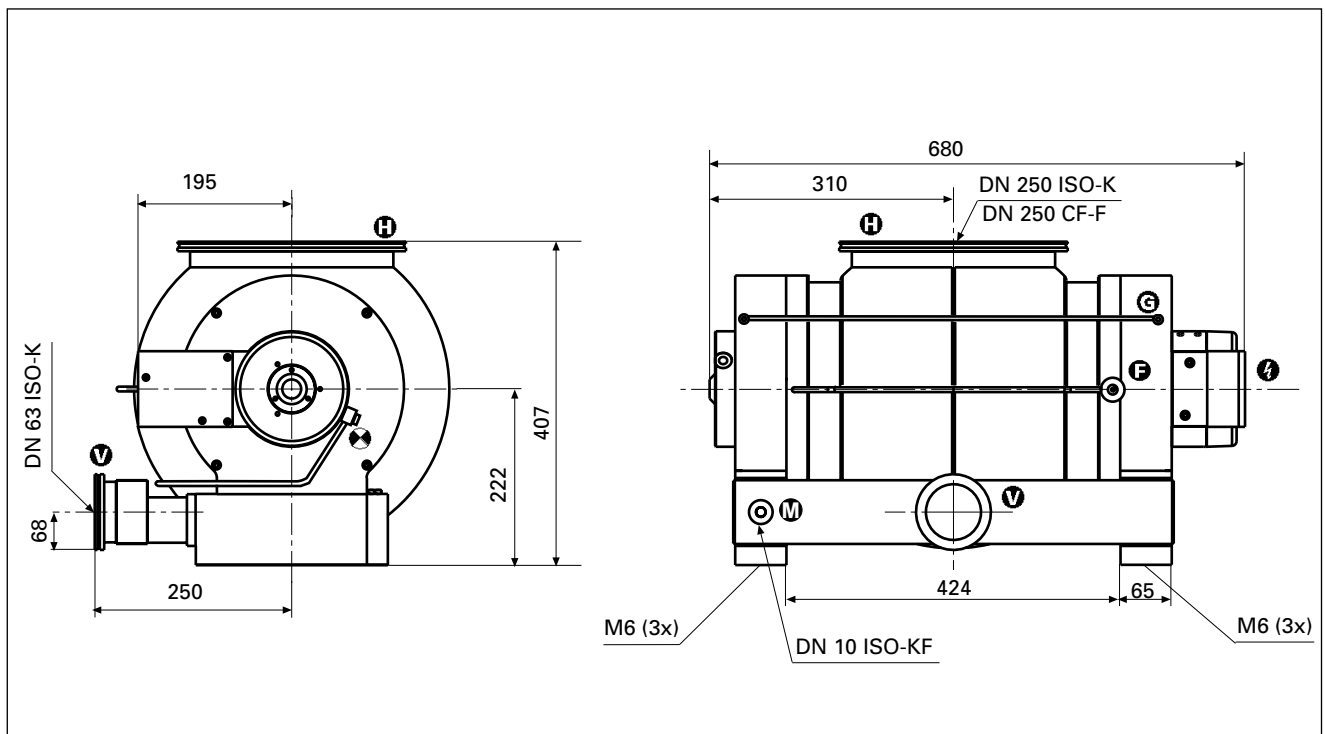

10. Spare Parts

Pos.	Description	Pieces	Size	Number	Comments	Order Quantity
	Spare parts TPH/TPU 2201					
	Set of seals			PM 003 445 -T		
17	USIT-ring	4	12,7/18 x 1,5	P 3529 142		
71	Lubricant filler screw	2	A2-50, G1/8" A	N 3191 382 X		
72	Lubricant drain screw	2	A2-50, G1/8" A	N 3191 382 X		
73	Sight glass	2		PM 003 251		
74	O-ring	2	57 x 2,5	P 4070 853 PP		
75	O-ring	4	6 x 2,2	P 4070 088 PP		
76	O-ring	2	22 x 3	P 4070 384 PP		
77	Lubricant pump	2	(für TL 011)	PM 043 531 -U		
77	Lubricant pump	2	(für F3)	PM 023 625 -U		
78	Ball bearing	4		P 4009 212 DB		
79	Floater	2		PM 033 306 -X		
81	Strainer	2				
88	O-ring	12	10 x 2,5	P 4070 166 PP		
87	O-ring	2	6 x 2,2	P 4070 088 PP		
94	Switch	2		PM 013 685 -X		

Spare parts

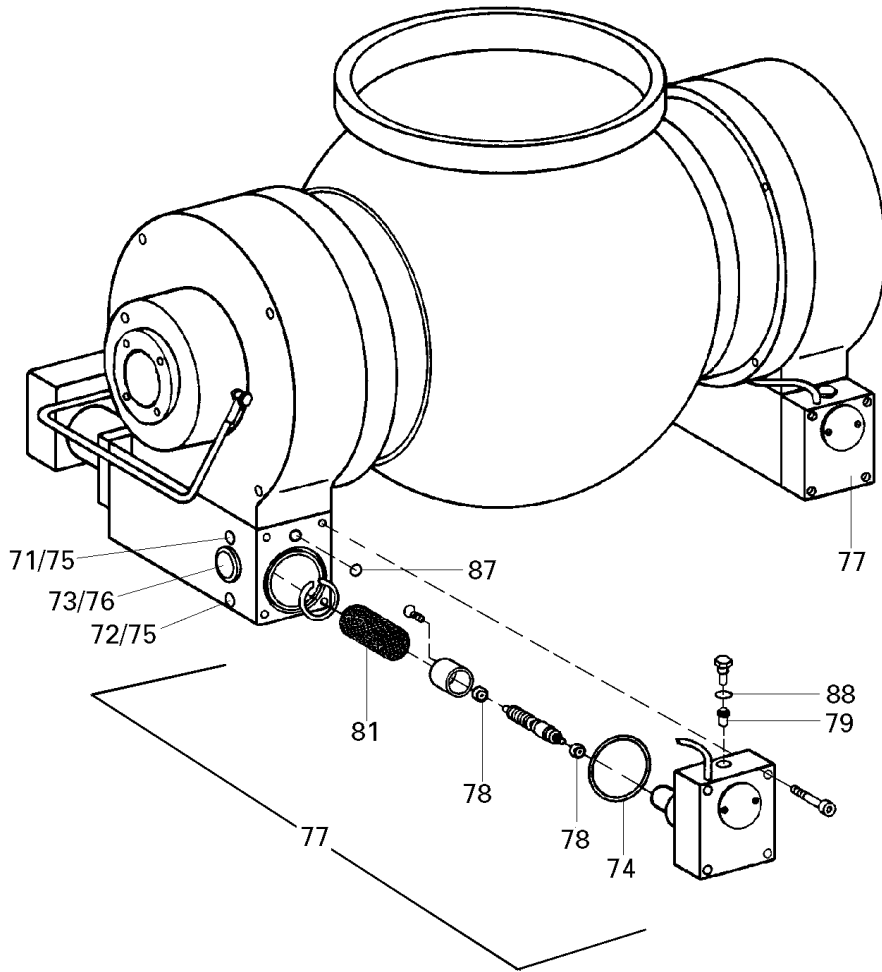

C40-758/1

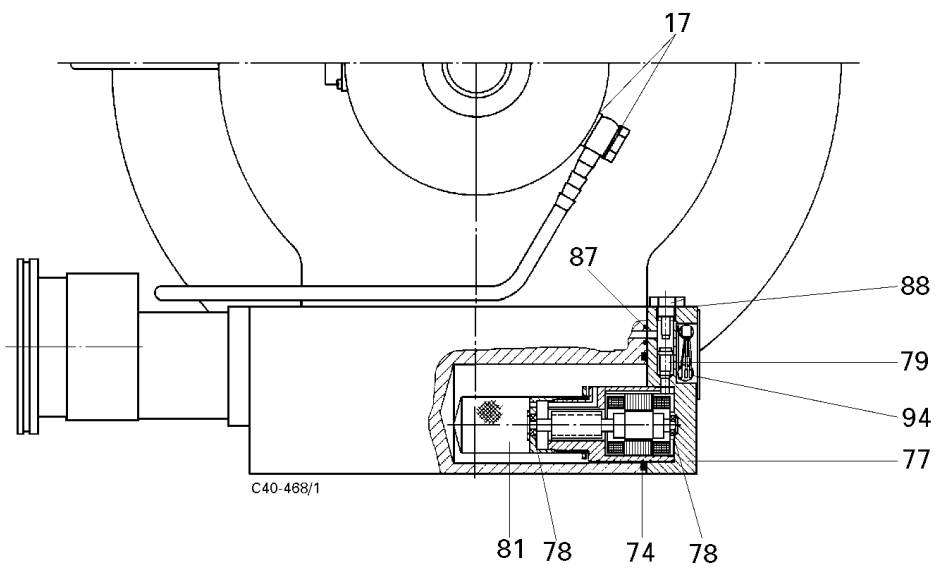

C40-468/1

11. Accessories

Description	Size	Number	Comments/ Operating Instructions	Order Quantity
Componets for cooling Dirt trap Recycled Water Cooling Unit TZK 2000	R 3/8" 230 V, 50 Hz	P 4161 300 2R PM Z01 240	PM 800 369 BN	
Components for venting Venting Valve TVF 005, without current closed Drying Unit TTV 001 (filled with zeolite) Venting flange	24 VDC PM Z00 121 DN 10 ISO-KF	PM Z01 135 PM 800 022 BN PM 033 737 -T	PM 800 507 BN	
Components for heating Heating	230 V, Schukostecker 208 V, UL-Stecker	PM 051 317 -T PM 051 318 -T		
Other accessories Connecting cable, TC 600-TPS/DCU Power pack unit – TPS 600; for fitting to walls or standard runners – TPS 600; 19"-insert unit – DCU 600; 19"-insert unit with Operating and Display Control Unit (DCU) Mains cable Safety plug UL-plug UL-plug Operating and Display Control Unit DCU 001 Relay box, backing pump 1 phase 16 A Safety plug UL-plug UL-plug PWM-adapter box Level converter RS 232/485 Vibration compensator, TPH TPU Bellow TPH Splinter shield Protective mesh Sealing ring, TPH Collar flange with retaining ring TPH CU-seal (10 pieces), TPU Set of screws, TPU Sealing gas valve Hose nipple Fore-Vacuum Safety Valve TVV 001 Syringe	3m 230 V 208 V 115 V 230 V 208 V 115 V DN 250 ISO-K DN 250 CF-F DN 250 ISO-K DN 250 DN 250 DN 250 DN 250 DN 250 DN 250 DN 250 CF DN 250 CF DN 10 ISO-KF DN 16 ISO-KF-10 115 V 230 V	PM 051 103 -T PM 800 521 BN PM 041 821 -T PM C01 697 P 4564 309 ZA P 4564 309 ZF P 4564 309 ZE PM 041 816 -T PM 041 920 -T PM 041 921 -T PM 041 922 -T PM 051 028 -U PM 051 054 -X PM 006 670 -X PM 006 671 -X PF 318 225 -X PM 006 984 AX PM 016 077 -X PF 303 125 -T BN 845 073 -T BN 845 322 -T BN 845 014 -T PM Z01 142 PF 144 020 PM Z01 206 PM Z01 205 PM 006 296 -U	other lengths on request PM 800 521 BN PM 800 477 BN PM 800 544 BN PM 800 544 BN PM 800 544 BN PM 800 563 BN PM 800 549 BN PM 800 229 BN for connecting the sealing gas valve PM 800 263 BN	

Declaration of Contamination of Vacuum Equipment and Components

The repair and/or service of vacuum components will only be carried out if a correctly completed declaration has been submitted. Non-completion will result in delay.

The manufacturer could refuse to accept any equipment without a declaration.

This declaration can only be completed and signed by authorised and qualified staff:

1. Description of component:

- Equipment type/model: _____
- Code No.: _____
- Serial No.: _____
- Invoice No.: _____
- Delivery Date: _____

2. Reason for return:

3. Equipment condition

- Has the equipment been used?
yes no
- What type of pump oil was used?

- Is the equipment free from potentially harmful substances?
yes (go to section 5)
no (go to section 4)

4. Process related contamination of equipment

- toxic yes no
- corrosive yes no
- microbiological hazard*) yes no
- explosive*) yes no
- radioactive*) yes no
- other harmful substances yes no

*) We will not accept delivery of any equipment that has been radioactively or microbiologically contaminated without written evidence of decontamination!

Please list all substances, gases and by-products which may have come into contact with the equipment:

Tradename Product name Manufacturer	Chemical name (or Symbol)	Danger class	Precautions associated with substance	Action if spillage or human contact
1.				
2.				
3.				
4.				
5.				

5. Legally Binding Declaration

I hereby declare that the information supplied on this form is complete and accurate. The despatch of equipment will be in accordance with the appropriate regulations covering Packaging, Transportation and Labelling of Dangerous Substances.

Name of Organisation: _____

Address: _____ Post code: _____

Tel.: _____

Fax: _____ Telex: _____

Name: _____

Job title: _____

Date: _____ Company stamp: _____

Legally binding signature: _____

Herstellereklärung Manufacturer's Declaration

im Sinne folgender EU-Richtlinien:
pursuant to the following EU directives:

- **Maschinen/Machinery 98/37/EG**
- **Elektromagnetische Verträglichkeit/Electromagnetic Compatibility 89/336/EWG**
- **Niederspannung/Low Voltage 73/23/EWG**

Hiermit erklären wir, daß das unten aufgeführte Produkt zum Einbau in eine Maschine bestimmt ist und daß deren Inbetriebnahme so lange untersagt ist, bis festgestellt wurde, daß das Endprodukt den Bestimmungen der EU-Richtlinie 98/37/EG, Anhang II B entspricht.

Wir bestätigen Konformität mit der EU-Richtlinie über elektromagnetische Verträglichkeit 89/336/EWG und der EU-Niederspannungsrichtlinie 73/23/EWG.

We hereby certify that the product specified below is intended for installation in a machine which is forbidden to be put into operation until such time as it has been determined that the end product is in accordance with the provision of EU Directive 98/37/EEC, Annex II B.

We certify conformity with EU Electromagnetic Compatibility Directive 89/336/EEC and EU Low Voltage Directive 73/23/EEC.

Produkt/Product:

TPH 2201 / TPU 2201

Angewendete Richtlinien, harmonisierte Normen und angewendete, nationale Normen:

Guidelines, harmonised standards, national standards in which have been applied:

**EN 292-1, EN 292-2, EN 294,
EN 1012-2, EN 61010**

Unterschrift/Signature:



Pfeiffer-Vacuum GmbH
Emmeliusstrasse 33
35614 Asslar
Germany

(W. Dondorf)
Geschäftsführer
Managing Director

Herst.l./2000

Zentrale/Headquarters

Pfeiffer Vacuum GmbH
 Emmeliusstrasse 33
 D-35614 Asslar
 Telefon 06441/802-0
 Telefax 06441/802-202
 Hotline 06441/802-333
 Internet:
<http://www.pfeiffer-vacuum.de>

Argentina

ARO S.A., Casilla de Correo 4890,
 1000 Buenos Aires, telephone +54 / 1 331 3918,
 telefax +54 / 1 331 3572

Australia

Balzers Australia Pty. Ltd., Level 1,
 3, Northcliff Street, Milsons Point, NSW 2061,
 telephone +61 / 2 9954 1925, telefax +61 / 2 9954 1939

Austria

Pfeiffer Vacuum Austria GmbH
 Diefenbachgasse 35, A-1150 Wien,
 telephone +43 / 1 8941 704, telefax +43 / 1 8941 707
 Service Hotline: +43 / 1 8941704

Branch Office, Czech Republic

Pfeiffer Vacuum Austria GmbH, Branch Prague
 Zvonarska 885
 CZ-156 00 Praha 5
 telephone + 420/2 900 42981
 telefax + 420/2 579 23014

Belgium / Luxembourg

Pfeiffer Vacuum Belgium N.V./S.A.
 Luxemburgstraat 5, B-1940 Temse
 telephone +32 / 3 710 5920, telefax +32 / 3 710 5929
 Service Hotline: +32 / 3 710 5922

Brazil

Elmi Tec
 Assistencia Técnica e Representação S/C Ltda.
 Rua Bernadino de Compos, 551
 CEP 04620-002 São Paulo, SP - Brasil
 telephone +55 / 11 532 0740
 telefax +55 / 11 535 3598

Chile

BERMAT S.A., Coyancura 2283, piso 6
 Providencia, P.O. Box 9781, Santiago
 telephone +56 / 2 231 8877,
 telefax +56 / 2 231 4294

Colombia

Arotec Colombiana S.A., Carrera 15 No.38-17
 P.O. Box 050 862, Santafe de Bogota / D.C.
 telephone +57 / 1 288 7799, telefax +57 / 1 285 3604

Denmark

Pfeiffer Vacuum Scandinavia AB, Vesterengen 2,
 DK-2630 Taastrup,
 telephone +45 / 43 52 38 00
 telefax +45 / 43 52 38 50

France

Pfeiffer Vacuum France SAS
 45, rue Senouque, BP 139 F-78531 BUC Cedex
 telephone +33 / (0)1 30 83 04 00
 telefax +33 / (0)1 30 83 04 04

Germany

Pfeiffer Vacuum GmbH,
 Emmeliusstrasse 33, D-35614 Asslar
 telephone +49 / 6441 802 400
 telefax +49 / 6441 802 399
 Service Hotline: +49 / 6441 802 333

Great Britain

Pfeiffer Vacuum Ltd.
 Bradbourne Drive, Tilbrook,
 Milton Keynes, MK7 8AZ, United Kingdom
 telephone +44 / 1 908 373 333
 telefax +44 / 1 908 377 776

Greece

Analytical Instruments S.A., 1 Mantzarou St.,
 GR-15451 Athens,
 telephone +30 / 1 674 8973
 telefax +30 / 1 674 8978

India

Pfeiffer Vacuum India Ltd.
 25-E Nicholson Road, Tarbund
 Secunderabad 500 009,
 telephone +91 / 40 775 0014, telefax +91 / 40 775 7774

Israel

ODEM Scientific Applications,
 2 Bergman Street, Science based park
 Rehovod
 telephone +972 8 9366 101,
 telefax +972 8 9366 102

Italy

Pfeiffer Vacuum Italia S.p.a.
 Via San Martino, 44 I-20017 RHO (Milano)
 telephone +39 / 2 93 99 051, telefax +39 / 2 93 99 05 33

Japan

Hakuto Co. Ltd., C.P.O. Box 25,
 Vacuum & Scientific Instruments Division
 Tokyo Central 100-91,
 telephone +81 / 3 32 258 910
 telefax +81 / 3 32 259 009

Korea

Pfeiffer Vacuum Korea Ltd., 3F Haein Building 453,
 Dokok-Dong, Kang Nam-Ku, Seoul, 135-270
 telephone +82 / 2 3461 0671/5
 telefax +82 / 2 3461 0676

Netherlands

Pfeiffer Vacuum Nederland BV
 Veldzigt 30a, NL-3454 PW De Meern,
 telephone +31 / 30 6660050, telefax +31 / 30 6662794

Peru

Ing. E. Brammertz s.r.l., José Pardo 182,
 Apartado 173, PE-18 Miraflores,
 telephone +51 / 1 445 8178
 telefax +51 / 1 445-1931

Poland

Softtrade Sp.z.o.o, ul. Malwowa 35,
 PL-60-175 Poznan, telephone +48 / 61 8677 168,
 telefax +48 / 61 8677 111

Portugal

Unilaser Lda, Taguspark
 Núcleo Central, sala nº 268, Estrada Cacém-
 Porto Salvo, P-2780 Oeiras
 telephone +351 / 1 421 7733
 telefax +351 / 1 421 7744

Singapore

APP Systems Services Pte. Ltd, 2 Corporation Road
 06-14 Corporation Place, Singapore 618494,
 telephone +65 / 268 2024, telefax +65 / 268 6621

Spain

Tecnovac
 Tecnologia de Vacío S.L., Ronda de Poniente, 6 Bajo F
 Centro Empresarial Euronova
 E-28760 Tres Cantos (Madrid)
 telephone +34 / 91 804 11 34,
 telefax +34 / 91 804 30 91

Sweden

Pfeiffer Vacuum Scandinavia AB
 Johanneslundsvägen 3
 S-194 61 Upplands Väsby
 telephone +46 / 590 748 10
 telefax +46 / 590 748 88

Switzerland

Pfeiffer Vacuum Schweiz S.A.
 Förrlibuckstraße 30, CH-8005 Zürich
 telephone +41 / 1 444 2255,
 telefax +41 / 1 444 2266

South Africa

Labotec Pty Ltd., P.O. Box 6553,
 Halfway House
 1685 Midrand
 telephone +27 / 11 315 5434
 telefax +27 / 11 315 5882

Taiwan

S & T Hitech Ltd. Hsinchu office
 No. 103, Hsien Chen 11th Street, Jubei City,
 HsinChu County, Taiwan, R.O.C.
 (zip/postal code: 302)
 telephone +886 / 3 554 1020
 telefax +886 / 3 554 0867

Thailand

S & T Enterprises (Thailand) Ltd.
 18th Floor, Chokchai Int'l Bldg.
 690 Sukhumvit Road
 Klongton, Klongtoey
 Bangkok 10110
 telephone +662 / 259 4623
 telefax +662 / 259 6243

U.S.A.

Pfeiffer Vacuum, Inc.
 24 Trafalgar Square
 Nashua, NH 03063-1988
 USA
 telephone +1/ 603 578 6500
 telefax +1/ 603 578 6550

Venezuela

Secotec S.A., Apartado 3452, Caracas 1010-A,
 telephone +58 / 2 573 8687
 telefax +58 / 2 573 1932

Other countries

AVI - Applied Vacuum Industries GmbH
 Leginglenstrasse 17A; CH-7320 Sargans
 Switzerland
 telephone +41 / 81 710 03 80
 telefax +41 / 81 710 03 81

Scope of represented countries

Armenia, Azerbaijan, Bangladesh, Belarus, Bulgaria,
 Cambodia, Estonia, Georgia, Hong Kong, Kazakhstan,
 Kingdom of Nepal, Kirghizia, Latvia, Lithuania,
 Maldiva, Philippines, P.R. China, Rumania, Russia,
 Tajikistan, Turkmenistan, Ukraine, Uzbekistan, Vietnam

A.E.M.S.

Advanced Equipment Materials and Systems
 P.O. Box 25
 Föhrenweg 18
 FL-9496 Balzers
 telephone +41 / 75 380 0550
 telefax +41 / 75 380 0551

Scope of represented countries

Bahrain, Egypt, Iraq, Iran, Jordan, Kuwait, Lebanon,
 Lybia, Oman, Pakistan, Saudi-Arabia, Sudan, Syria,
 Turkey, United Arab Emirates, Yemen