

# TRIVAC<sup>®</sup> NT16 / NT25

## Rotary Vane Vacuum Pump

Operating Instructions 130002780\_002\_A1

**In the case of an attached explosion hazard rated motor (category 3 i/o), the information provided in the enclosed Operating Instructions for the electric motor must be observed!**

### Part Numbers

140 220	140 330
140 221	140 331
140 222	140 332
140 223	140 333
140 224	140 334
140 225	140 335
140 226	140 336
140 227	140 337
140 231	140 338
140 232	140 339
140 233	140 340
140 234	140 341
140 235	140 346
140 241	140 347



# Contents

	Page
<b>Important Safety Information</b>	<b>5</b>
<b>ATEX Directive and Flammable Gases Dilution</b>	<b>8</b>
<b>TRIVAC B ATEX - Categories 3 i and 3 i/o Vacuum Pump</b>	<b>9</b>
<b>1 Description</b>	<b>13</b>
1.1 Design and Function	15
1.1.1 Operating Agents	17
1.2 Supplied Equipment	18
1.3 Technical Data	19
1.3.1 Motor Related Data	20
1.4 Ordering Data	22
1.5 Accessories	23
<b>2 Transportation and Storage</b>	<b>24</b>
<b>3 Installation</b>	<b>25</b>
3.1 Placement	25
3.2 Conforming Utilization	26
3.3 Connection to the System	28
3.4 Electrical Connections	30
<b>4 Operation</b>	<b>32</b>
4.1 ATEX Directive and Flammable Gases Dilution	32
4.2 Media Compatibility	33
4.3 Start Up	33
4.4 Operation	34
4.4.1 Pumping of Non-Condensable Gases and Vapours	34
4.4.2 Pumping of Condensable Gases and Vapours	34
4.4.3 Operating Temperature	35
4.5 Shutdown	35

# Contents

	Page
<b>5 Maintenance</b>	<b>37</b>
5.1 Oerlikon Leybold Vacuum Service	37
5.2 Maintenance Plan (Recommendation)	38
5.3 Checking the Oil	39
5.4 Oil Change	40
5.5 Cleaning the Inlet Screen	42
5.6 Checking the Coupling	42
5.7 Replacing the Outer Shaft Seal	42
<b>6 Troubleshooting</b>	<b>45</b>
<b>7 Wearing and Original Parts</b>	<b>47</b>
<b>8 Waste Disposal</b>	<b>48</b>
<b>EC Declaration of Conformity</b>	<b>49</b>
<b>EC Manufacturer's Declaration</b>	<b>50</b>

# Safety Information



We strongly recommend that you read and observe the information provided in these Operating Instructions before installing and commissioning the TRIVAC NT with care so as to ensure optimum operation of the pump right from the start.

---

## Warning



The icon indicates procedures in these Operating Instructions that must be strictly observed to prevent hazards to persons.

## Warning



High electrical voltages! When touching parts at high-voltage there is the risk of suffering severe injury by an electric shock! Covers which are marked with this icon must only be removed by trained electricians after having reliably disconnected the electric power source.

---

## Caution

Indicates procedures that must strictly be observed to prevent damage to, or destruction of the equipment.

---

## Note

Emphasises additional application information and other useful information provided within these Operating Instructions.

The Oerlikon Leybold Vacuum **TRIVAC NT** has been designed for safe and efficient operation when used properly and in accordance with these Operating Instructions. It is the responsibility of the user to carefully read and strictly observe all safety precautions described in this section and throughout the Operating Instructions. The TRIVAC **must only be operated in the proper condition and under the conditions described in the Operating Instructions**. It must be operated and maintained by trained personnel only. Consult local, state, and national agencies regarding specific requirements and regulations. Address any further safety, operation and/or maintenance questions to your nearest Oerlikon Leybold Vacuum office.

---

## Figures

The references to diagrams, e.g. (4/1/2) consist of Chapter No., consecutive Fig. No. within the chapter and the Item No. in the figure in that order.

---

We reserve the right to modify the design and the specified data. The illustrations are not binding.

## Important Safety Information

Failure to observe the following precautions could result in serious personal injury!

- Before beginning with any maintenance or service work on the TRIVAC NT, disconnect the pump from all power supplies (lockout/tagout).
- Do not operate the pump with any of the covers removed. Serious injury may result.
- If exhaust gases must be collected or contained, do not allow the exhaust line to become pressurised.
- Make sure that the gas flow from the exhaust port is not blocked or restricted in any way.
- **Only** those pumps which are equipped with an Atex certified motor are suited for operation in explosion hazard areas.
- The standard version of the TRIVAC NT is not suited for operation in explosion hazard areas.
- Before starting up for the first time, the motor circuit must be equipped with a suitable protective motor switch. Please take note of the information in these Operating Instructions and on the electric motor (wiring diagram).
- When pumping toxic, chemical, radioactive and corrosive gases as well as pyrophorous substances, the operating company is under the obligation to comply with the national and international safety regulations and guidelines. Regarding the suitability of the TRIVAC NT pumps for special applications in which such gases, respectively substances shall be pumped, Oerlikon Leybold Vacuum should be consulted first.
- The TRIVAC NT pumps including the accessories are fundamentally not suited for pumping of combustible and explosive gases or vapours. Mixtures of substances may, regarding the fire and explosion risk be critical or uncritical. The operating company is under the commitment to analyse this and rate the hazard potential accordingly so as to therefrom derive the necessary safety measures which must be introduced.
- If ignitable or pyrophorous substances are present in the equipment you must ensure that:
  - no air can enter into the equipment,
  - the system is leak-tight,
  - by means of purging with inert gas (for example through a nitrogen purge) all ignitable gases or vapours which enter into the pump through the pump's inlet are diluted and/or by means of an inert gas purge the concentration of ignitable gases in the pump and in the exhaust gas line is reduced to less than a quarter of the lower explosion limit published for the respective gases.

---

### Warning



# Safety Information

---

## Warning



- Avoid exposing any part of the human body to the vacuum.
- Never operate the TRIVAC NT without a connected intake line or without fitting a blank flange.
- The location at which the TRIVAC NT (including its accessories) is operated should be such that angles over 10° from the vertical are avoided.
- The location of the TRIVAC NT should be such that all controls are easily accessible.
- Under certain ambient conditions the TRIVAC NT may attain a temperature of over 70 °C (158 °F). There then exists the danger of receiving burns. Note the symbols on the pump pointing to the hazards, and in the case of a hot pump wear the required protective clothing.
- All work on the pumps “at operating state temperature“ shall only be done while wearing protective gloves. Always let the pump cool down before any servicing and maintenance work.
- The noise level produced by the TRIVAC NT is 54 dB(A) max. Suitable hearing protection measures must be introduced.
- Before pumping oxygen (or other highly reactive gases) at concentrations exceeding the concentration in the atmosphere (> 21 % for oxygen) it will be necessary to use a special pump. Such a pump will have to be modified and de-greased, and an inert special lubricant (like PFPE) must be used.
- Before operating the TRIVAC NT check first compatibility with the pumped media so as to avoid hazardous conditions during operation right from the start. Observe all applicable safety standards and regulations.
- After a mains power failure the pump will run up automatically again. This also applies in the case of an emergency shutdown. In order to prevent the pump from running up automatically again, the pump must be integrated within a control arrangement such that it can only be switched on manually again after the mains power has returned.
- When operating the pumps at gas throughput, it is urgently recommended to connect an exhaust filter or use a suitable exhaust line. Here, the exhaust line must slope down and away from the pump.
- When moving the TRIVAC NT always use the allowed means. A lifting eye is provided as standard on the pump.
- The pump when filled with oil must only be moved in its vertical position. Spilled oil involves the risk of falling.
- **PFPE:** During thermal decomposition at temperatures over 290 °C toxic and corrosive gases are released. When handling PFPE keep it away from open fires. Do not smoke in the work area.
- **DOT 4:** When swallowing the operating agent there is the danger of being poisoned.
- DOT pumps are not suited for operation in explosion hazard areas or for pumping explosive substances.

## Failure to observe the following precautions could result in damage to the pump.

- Do not allow the ingestion of small objects (screws, nuts, washers, pieces of wire, etc.) through the inlet port. Always use the inlet screen which is supplied with every pump.
- Do **not** use the pump for applications that produce abrasive or adhesive powders or condensable vapours that can leave adhesive or high viscosity deposits. Please contact our Sales or Service offices to select a suitable separator. Also please contact our Sales or Service when planning to pump vapours other than water vapour.
- This pump is suited for pumping water vapour within the specified water vapour tolerance limits.
- Avoid vapours that can condense into liquids upon compression inside the pump, if these substances exceed the vapour tolerance of the pump.
- Before pumping vapours, the TRIVAC NT should have attained its operating temperature. The pump will have attained its operating temperature about 30 minutes after starting the pump. During this time the pump should be separated from the process, by a valve in the intake line, for example.
- In the case of wet processes we recommend the installation of liquid separators upstream and downstream of the pump as well as the use of the gas ballast.
- The exhaust line should be laid so that it slopes down and away from the pump so as to prevent condensate from backstreaming into the pump.
- The entry of particles and fluids must be avoided under all circumstances.
- Reactive or aggressive substances in the pump chamber may impair the operating oil or modify it. In addition, such substances may be incompatible with the materials of the pump (Viton, grey cast iron, aluminium, steel, resins, glass etc.).
- Corrosion, deposits and cracking of oil within the pump are not allowed.
- Normal amounts of humidity within the range of the pump's vapour tolerance will not significantly affect pump performance (when the gas ballast is active).
- In the case of custom pumps (with part numbers deviating from those stated in the EC Declaration of Conformity) please note the information provided in the supplementary sheets.
- If mineral oil, PFPE and DOT come into contact they will emulsify. That's why the pumps must only be run with the type of lubricant specified for the pump.
- Please note the change as to the ATEX temperature class in the case of PFPE pumps. Suitability is restricted to T3 (gases and vapours with an ignition temperature of over 200 °C).

---

## Caution

## **ATEX DIRECTIVE AND FLAMMABLE GASES DILUTION**

The TRIVAC NT 16 and 25 Atex Category 3 pumps are designed according to the requirements of Directive 94/9/EEC Group II, Category 3.

Depending on the respective catalogue number, these pumps are suited for use under Atex category 3 conditions .

Never use a pump certified for Category 3 internal in an external potentially explosive atmosphere, as the pump is not designed with respect to potential ignition sources outside.

In the case of a potential external explosive atmosphere, use only pumps certified for the ignition category 3 inside and outside.

During normal operation there is no potential source of ignition inside and outside the pump but, according to the 94/9/EC directive, a rare malfunction may occur with potential sources of ignition.

In normal operation, even if the pump is designed for flammable gases, the operation procedure must ensure that the gases are not within their explosion limits.

When flammable gases are pumped, the following safety measures must be enforced:

- Prevent any atmospheric air from entering into the pump.
- Use an inert gas to dilute the flammable gas being pumped; the concentration of flammable gas must not exceed 25% to 30% of the lower explosion limit.



## TRIVAC NT ATEX - Categories 3 i and 3 i/o Vacuum Pump

### Operating Instructions for Operation in Explosion Hazard Areas

The vacuum pumps from the line TRIVAC NT Category 3 have been designed and manufactured especially for the purpose of fulfilling the requirements of Equipment Group II, Category 3 of the "ATEX Directive" (Directive 94/9/EG) for conforming utilisation of equipment and protection systems in explosion hazard areas".

### Classification and Marking of the Pump

In the case of the standard TRIVAC NT the inside, i.e. the process gas side of the pump fulfils the basic safety requirements of the EU Directive 94/9/EG. The pump is supplied with an electric motor which is not ATEX certified and has for this reason been marked as follows:

 II (i) 3G IIC T4 (50 Hz / 60 Hz) X

This pump is **not** suited for being installed in explosion hazard areas.

Pumps where the inside and the outside of the pump fulfil the basic safety requirements of the Directive, are supplied with an ATEX certified motor and have been marked as follows:

 II (i) 3G IIC T4 (50 Hz / 60 Hz) X  
 II (o) 3G IIC T3 (50 Hz / 60 Hz) X

Please note the change as to the ATEX temperature class in the case of PFPE pumps. Suitability is restricted to T3 (gases and vapours with an ignition temperature of over 200 °C).

**Note the ATEX temperature class!**

### Explanation of the Symbols

- II** Equipment Group II applies to all equipment for use in areas which can be endangered by an explosive atmosphere except in underground mining operations and their related above ground systems which can be endangered by mine gas and/or combustible dust.
- (i)/(o)** Specifies the category/conditions according to which the inside (i) (i.e. sections of the equipment in contact with the process gas flow) and the outside (o) of the equipment are classified provided these differ.
- 3** Category 3 comprises equipment which is designed such that it can be operated in agreement with the characteristic quantities (operating parameters) specified by the manufacturer and which ensure a normal level of protection. Equipment belonging to this category is intended for use in areas where it needs not to be expected that an explosive atmosphere occurs due to gases, vapours and mists but, in case such an atmosphere should occur in spite of this then according to all probability only rarely and briefly. Equipment belonging to this category ensures during normal operation the required degree of safety.

**G** For areas with an explosive atmosphere caused by gases, vapours or mists in the air.

The pump is not suited for utilisation in dusty areas.

**IIA, IIB** or

**IIC** Explosion Groups: these are subdivisions for equipment belonging to Group II which is employed in connection with some protection types. This subdivision is based on the concept of the maximum permitted gap and the minimum ignition current of the explosive mixture. Refer to Annex A of the European Standard EN 50014. (EN 50014 electrical apparatus for potentially explosive atmospheres — General requirements.

Equipment marked with IIB is suited for applications which require equipment with the marking IIA. Correspondingly equipment marked with IIC is suited for applications which require equipment belonging to Exploding Group IIA or IIB.

**T3, T4** Temperature class: classification of operating means depending on their maximum surface temperature, in agreement with the following table:

Temperature class	Maximum surface temperature (°C)
T1	450
T2	300
T3	200
T4	135
T5	100
T6	85

Pumps belonging to temperature class T4 (with 50 Hz electric motors) must only be operated with gases or vapours which exhibit an ignition temperature of over 135° C.

Pumps belonging to temperature class T3 (with 60 Hz electric motors) must only be operated with gases or vapours which exhibit an ignition temperature of over 200° C.

The temperature class and the actual maximum surface temperature of the equipment includes a safety margin with respect to the minimum ignition temperature of the potentially explosive atmosphere as demanded by EN 13463-1.

**50 Hz**

**60 Hz** Frequency of the electric motor – at a higher frequency the pump will run faster and produce a higher surface temperature.

**Ta** Permissible ambient temperature for operating the pump  
 $12\text{ °C} < T_a < 40\text{ °C}$ .

**X** Special operating conditions need to be complied with! The special conditions and notes provided in the Operating Instructions apply.

## Protective Measures

### Hot Surfaces

During normal operation of the vacuum pump, compression of the gases causes the surfaces to heat up resulting in hot surfaces. Tests have shown in the case of conforming operation of the pump (in accordance with these instructions) that at the inside of the pump which might come into contact with a potentially explosive atmosphere attains during operation with a 50 Hz motor a maximum temperature of less than 135° C and during operation with a 60 Hz motor a maximum temperature of less than 200° C.

The maximum temperatures are attained during continuous operation at an inlet pressure ranging between 300 and 500 mbar. The actually attained temperature depends on the inlet pressure.

The outside of the pump may attain under these conditions a surface temperature of over 80° C. The maximum temperature is in the case of operation with a 50 Hz motor less than 135° C and in the case of operation with a 60 Hz motor less than 200° C.

(These temperatures include safety margins in accordance with EN 13463-1.)

Higher maximum surface temperatures can occur when filling and operating the pump with types of oil which differ from the Leybold oil N 62. This is due to the frequently worse lubrication and cooling properties of such oil, PFPE in particular.

### Hot Exhaust Gases

Due to the compression of the gases, the pump will produce in the case of normal operation hot exhaust gases. The exhaust gas temperatures do not exceed the maximum surface temperatures stated for the pump.

For this reason the exhaust gases need to be disposed of through a suitable exhaust gas system.

### Mechanical Sparks

During normal operation no mechanically produced sparks occur since the internal surfaces of the pump are covered with oil. The external fan and the fan cover are so designed that a sufficient clearance is maintained thereby excluding the possibility of a contact.

Sucking in of particles into the pump needs to be avoided so as to prevent the formation of hot spots due to friction.

### Electric Sparks

These can be caused by the electric motor and the accessories supplied with the pump. If the pump has been approved for operation in areas with an explosive atmosphere, then motor and supplied accessories have the same classification as the pump. Motor and accessories need to be installed and used in agreement with the enclosed manufacturer's information.

#### Warning



#### Note



#### Note





### Static Electricity

The pump needs to be sufficiently grounded so as to avoid any electrostatic charging. This is attained when properly connecting the electric ground conductor to the motor. During normal operation no hazardous generation of charges will occur on the plastic coupling or the fan (for further information relating to the hazards caused by static electricity, see CENELEC report CLC/TR 50404: 2003 Electrostatics - Code of practice for the avoidance of hazards due to static electricity).

### Note

Only original Leybold oil filters and gas inlet filters must be used since these have been designed such that proper connection to ground is ensured. Dust on the surfaces must only be removed using a moist piece of cloth so as to exclude the possibility of generating sparks.



### Chemical Reactions

The pump must not be used in connection with reactive or corrosive gases, which might result in an exothermal chemical reaction.

### Additional Safety Measures

Overheating the pump can give rise to temperatures which exceed the maximum permitted surface temperature.

### Maintain the correct oil level

In order to prevent overheating, installation and maintenance need to be done in accordance with the information provided in these Operating Instructions. Especially the correct oil level needs to be maintained.

The oil must be exchanged within the recommended interval or earlier if contaminated by the process gas.

### Additional Maintenance Requirements

In those cases where dust can deposit itself on the pump or the motor surfaces, measures must be introduced which ensure that such deposits are removed on a regular basis.

In order to ensure that the defined safety level is complied with, use only original Leybold spare parts.

In addition to the maintenance work described in the Operating Instructions every 15.000 operating hours or every three years a complete refurbishment of the pump including a replacement of the bearings and the couplings should be scheduled.

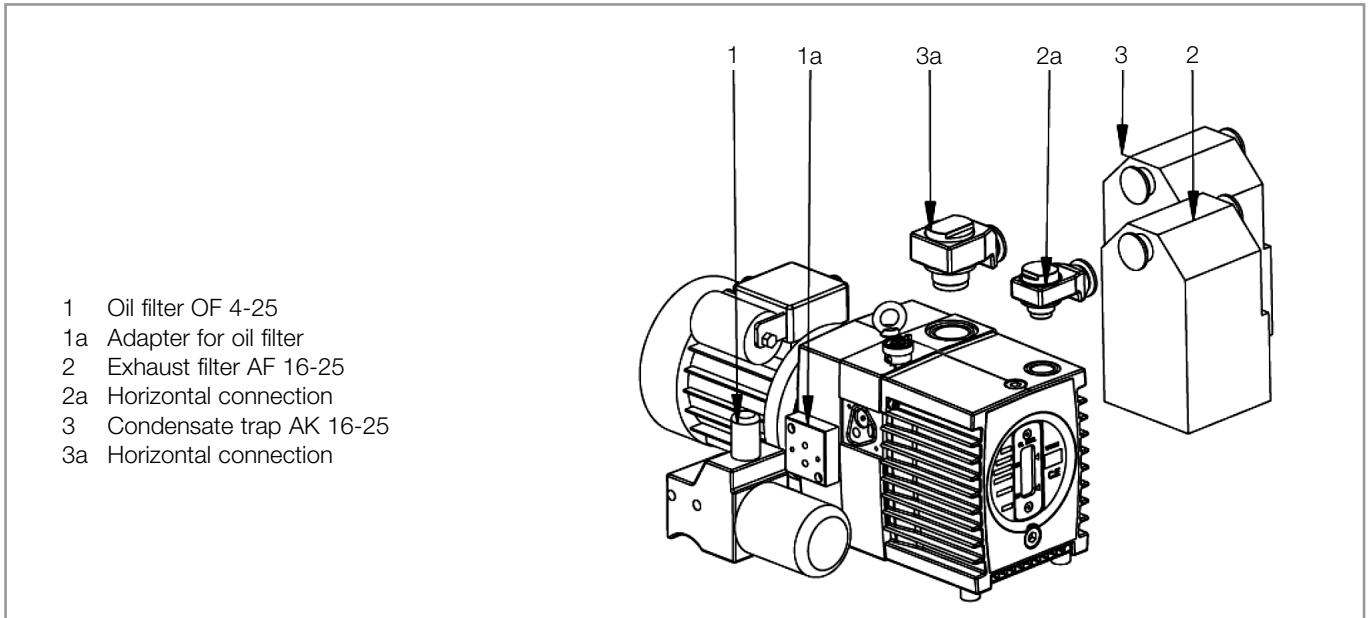

Fig. 1.1 TRIVAC NT with accessories

## 1 Description

The TRIVAC NT pumps are oil sealed vacuum pumps of the rotary vane type. The TRIVAC NT 16 ATEX and NT 25 ATEX are two-stage pumps. The number in the type designation (16 or 25) indicates the pumping speed of the pump in  $\text{m}^3 \cdot \text{h}^{-1}$ .

The vacuum pumps from the line TRIVAC NT Category 3 have been designed and manufactured especially for the purpose of fulfilling the requirements of Equipment Group II, Category 3 of the “ATEX Directive” (Directive 94/9/EG) for conforming utilisation of equipment and protection systems in explosion hazard areas”

TRIVAC NT pumps are capable of pumping gases and vapours and evacuating vessels or vacuum systems down into with the medium vacuum range. The standard versions of the pump are not suited for pumping of oxygen exceeding the concentration as found in the atmosphere, and are also not suited for pumping of hazardous gases or extremely aggressive or corrosive media.

The inside (the process gas side) of this vacuum pump is so designed and rated that the occurrence of foreseeable ignition sources can be excluded during normal operation. Provided the pump is operated within the limits of the parameters specified in the Operating Instructions, the pump will offer a normal degree of protection. It is therefore suited for operation under conditions under which it is unlikely that explosive atmospheres are caused by gases, vapours or mists in the air or should these occur then only rarely and for a short period of time (i.e. Zone 2). The same conditions apply to outside components of the pumps which have been certified.

## Operating Principle

# Description

---

**Note**

---

If only the inside of the pump (process side) has been certified for use in explosive atmospheres, then the pump itself must not be installed and operated within explosion hazard areas.

Areas in which explosive atmospheres (gases, vapours or mists) in the air can occur are classified in three zones according to the frequency and the duration of the occurrence of an explosive atmosphere.

**Zone 0, 1 and 2**

These zones are designated as Zone 0, 1 and 2. The definitions for these zones are described in the Annex I of the "Atex Directives (Directive 99/92/EG) for the improvement of health protection and safety of staff which might be endangered by explosive atmospheres".

Notes relating to the definitions for the three zones relating to areas with explosive atmospheres are given in the Directive 99/92/EG and the corresponding guide (COM (2003) 515), together with the European standard EN 60079-10 (Electrical apparatus for explosive gas atmospheres. - Part 10 Classification of hazardous areas). Additionally further information on the avoidance of explosions and on the topic of explosion protection can be found in the Directive 99/92/EG and the corresponding guide.

This information can be downloaded from the EU Internet site:  
[www.europa.eu.int](http://europa.eu.int):

[http://europa.eu.int/eur-lex/de/com/cnc/2003/com2003\\_0515de.html](http://europa.eu.int/eur-lex/de/com/cnc/2003/com2003_0515de.html)

[http://europa.eu.int/eur-lex/en/com/cnc/2003/com2003\\_0515en.html](http://europa.eu.int/eur-lex/en/com/cnc/2003/com2003_0515en.html)

[http://europa.eu.int/eur-lex/fr/com/cnc/2003/com2003\\_0515fr.html](http://europa.eu.int/eur-lex/fr/com/cnc/2003/com2003_0515fr.html)

Alternatively the guide of the EU commission on ATEX (reference number. COM 2003 0515) can also be read by accessing the link

<http://europa.eu.int/eur-lex/>

**Responsibility of the operator**

Conforming utilisation of the Trivac pumps and compliance with the statutory requirements of the ATEX operator directive (99/92/EG) is the responsibility of the operator.

**Drive concept**

The drive motor of the TRIVAC B is directly flanged to the pump at the coupling housing. The pump and motor shafts are directly connected by a flexible coupling. The bearing points of the pump module are force lubricated sliding bearings. All controls as well as the oil-level glass and the nameplate are arranged on the front. All connections are to be found at the sides of the pump. The oil-level glass is provided with prisms for better observation of the oil level.

The pump module consists of assembly parts which are pin-fitted so as to allow easy disassembly and reassembly. The pump module can be easily removed without special tools.

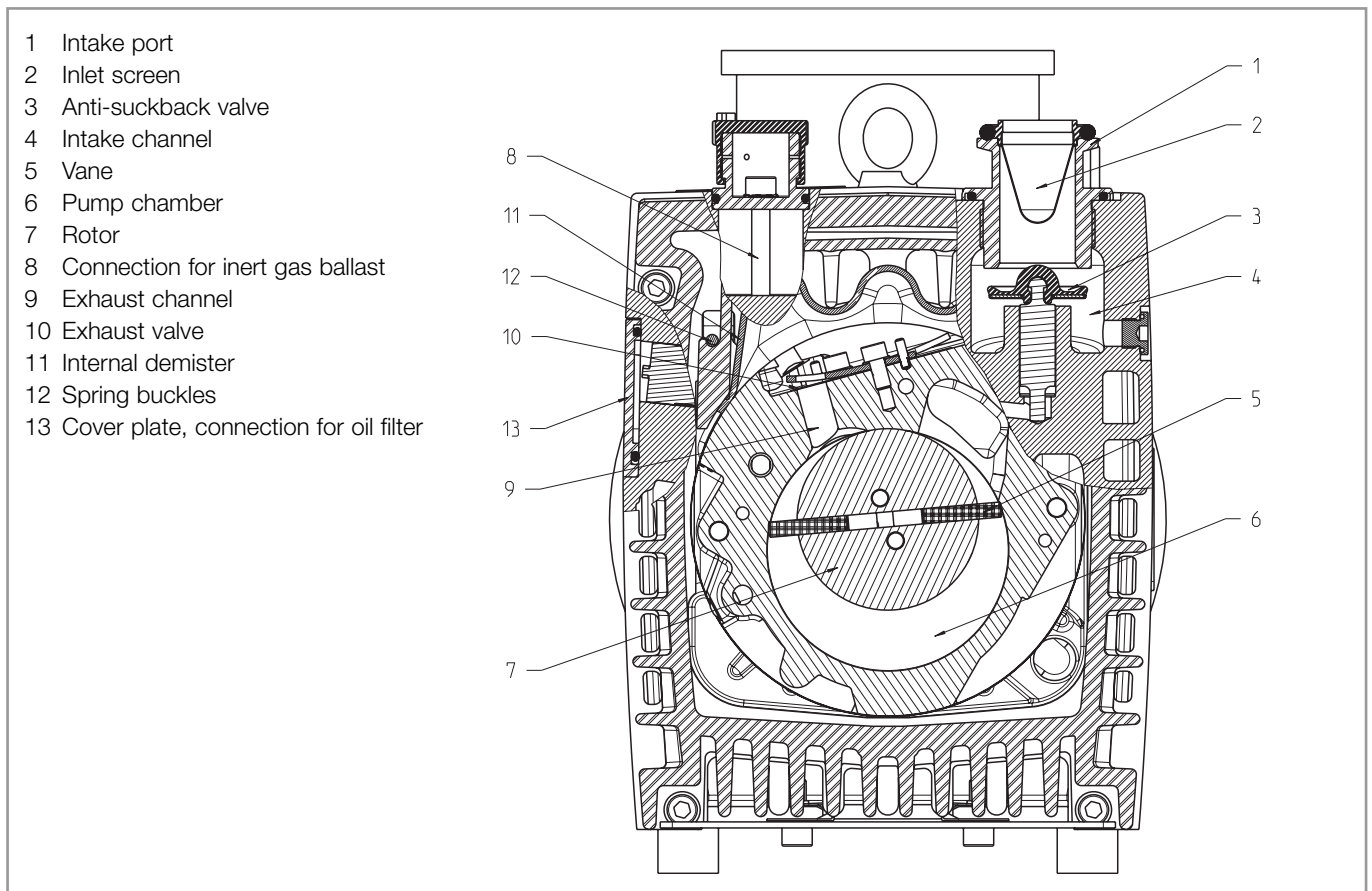

Fig. 1.2 Sectional drawing of the TRIVAC NT

## 1.1 Design and Function

The rotor (1.2/7), mounted eccentrically in the pump housing, has two radially sliding vanes (1.2/5) which divide the pump chamber into several compartments. The volume of each compartment changes periodically with the rotation of the rotor.

As a result, gas is sucked in at the intake port (1.2/1). The gas passes through the dirt trap sieve (1.2/2), flows past the open anti-suckback valve (1.2/3) and then enters the pump chamber (1.2/6). In the pump chamber, the gas is passed on and compressed, after the inlet aperture is closed by the vane.

The oil injected into the pump chamber is used for sealing and lubricating. The slap noise of the oil in the pump which usually occurs when attaining the ultimate pressure is prevented by admitting a very small amount of air into the pump chamber.

The compressed gas in the pump chamber is ejected through the exhaust valve (1.2/10). The oil entrained in the gas is coarsely trapped in the internal demister (1.2/11); there the oil is also freed of mechanical impurities. The gas leaves the TRIVAC NT through the exhaust port.

During compression, a controlled amount of air - the so-called gas ballast - can be allowed to enter the pump chamber by opening the gas ballast valve

# Description

(position I). The gas ballast stops condensation of vapours in the pump chamber up to the limit of water vapour tolerance as specified in the technical data for the pump.

The gas ballast valve is opened and closed in two steps by turning the gas ballast knob (3.1/5) on the top.

To enable the TRIVAC NT to be used at intake pressures as high as 1,000 mbar, a special lubricating system was developed featuring force-lubrication of the sliding bearings.

An oil pump (1.3/6) pumps the oil from the oil reservoir (1.3/5) into a pressure-lubrication system which supplies oil to all bearing points (1.3/2). From there the oil enters the pump chamber area (1.2/6) of the vacuum pump.

The oil pump is fitted in the front end plate on the coupling side of the pump module. The oil suction line is placed low, resulting in a large usable oil reservoir.

The oil is separated from the gas in the TRIVAC NT in two steps as described above. First, small droplets are coalesced into large drops in the internal demister (1.2/11) fitted above the exhaust valve (1.2/10). Then, the large drops fall into the oil reservoir as the exhaust gas is diverted by the inner walls of the oil case. Thus a low loss of oil is obtained. This and the large usable oil reservoir ensure long intervals between oil changes even at high intake pressures.

The vacuum is maintained by the TRIVAC NT by an integrated hydropneumatic anti-suckback valve (1.2/3) which is controlled via the oil pressure.

During operation of the TRIVAC NT the control piston (1.4/3) remains sealed against a spring (1.4/2) by the oil pressure. The valve disc (1.4/6) of the anti-suckback valve is held at the lower position by its own weight (valve open). When the pump stops (because it has been switched off or because of a failure), the oil pressure drops and the spring (1.4/2) presses the control piston (1.4/3) up. Thus a connection is provided between the oil case or the oil reservoir (1.4/1) and the piston (1.4/4) of the anti-suckback valve. Due to the pressure difference between the oil case and the intake port the oil presses the piston (1.4/4) up and the valve plate (1.4/6) against the valve seat (1.4/5). The quantity of oil in the oil reservoir (1.4/1) prevents the entry of air into the intake port (1.2/1) at the beginning of this process.

After the oil has flowed out from the reservoir and when the valve plate rests on the valve seat, air follows in, which vents the pump chamber and forces the valve disc (1.4/6) against its seat. This effectively prevents backstreaming of oil. The anti-suckback valve (1.2/3) operates independently of the operating mode of the pump, i.e. also with gas ballast.



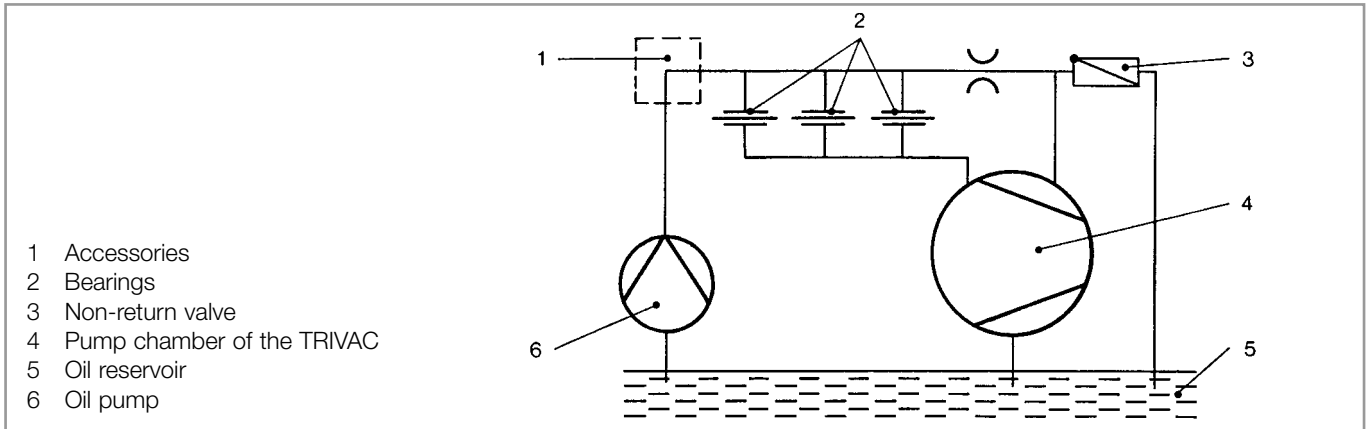

Fig. 1.3 Schematic of the lubricating system

## 1.1.1 Operating Agents

The standard TRIVAC NT pumps are either ready for operation with **mineral oil**, diester oil, the operating agent **DOT 4** (brake fluid) or with the special lubricant, perfluoropolyther (**PFPE**).

If mineral oil, PFPE and DOT come into contact they will emulsify. That's why the pumps must only be run with the type of lubricant specified for the pump. If you want to change the type of lubricant Oerlikon Leybold Vacuum should do the change.

### When handling PFPE you should observe the following:

Please note the change as to the ATEX temperature class in the case of PFPE pumps. Suitability is restricted to T3 (gases and vapours with an ignition temperature of over 200 °C).

During thermal decomposition at temperatures over 290 °C toxic and corrosive gases are released. When handling PFPE keep it way from open fires. Do not smoke in the work area.

Touch the inner sections of the pumps only while wearing clean gloves, and use clean tools;

Do the necessary work in clean and dry rooms;

After having removed the pump from its packaging, start it up as quickly as possible;

While working on the pump, do not eat, drink or smoke.

As cleaning agents solvents based on hydrofluorether compounds may be used.

### Information on the pump's operating agent DOT 4

The pumps are equipped with special seals which are capable of resisting exposure to brake fluids. These pumps must only be operated with brake fluids in accordance with DOT 3 and DOT 4 or alternative operating agents which have been approved by Oerlikon Leybold Vacuum.

### Warning



# Description

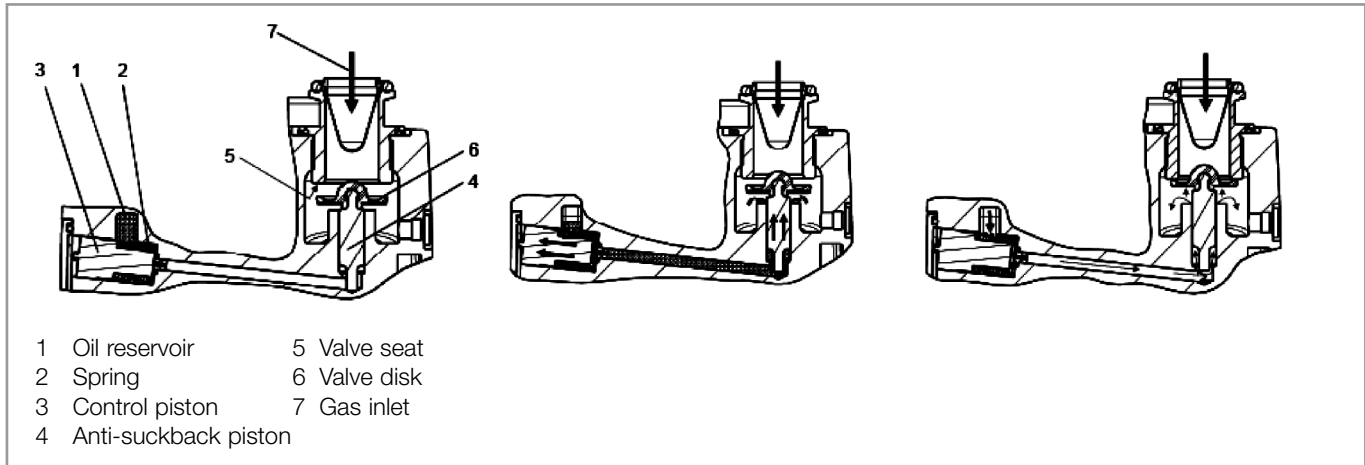

Fig. 1.4 Hydropneumatic anti-suckback valve

Store the operating agent only in its original container in a clean and dry place. Keep the container firmly sealed.

---

### Warning



DOT pumps are not suited for operation in explosion hazard areas or for pumping explosive substances.

Any contamination by dirt, water, crude oil products or other materials may result in damage to the pump.

Operating agent which has been used must never be re-used.

The operating agent will attack (dissolve) paint.

---

### Warning



When swallowing the operating agent there is the danger of being poisoned.

Always keep the operating agent in a sealed container and out of reach of children.

## 1.2 Supplied Equipment

The equipment supplied with the TRIVAC NT pump includes:

Pump with motor, including initial filling of oil

- 1 centering ring,
- 1 centering ring with dirt trap,
- 2 clamping rings DN 25 KF.

As protection during shipment, the connection ports are each blanked off by rubber diaphragms and supporting rings.

TRIVAC NT pumps with single-phase AC motor are supplied with switch, built-in thermal motor protection switch and plug for the mains cable.

For TRIVAC NT pumps with three-phase AC motor, the switch, motor protection switch, mains cable etc. are not included.

## 1.3 Technical Data

		TRIVAC NT 16	TRIVAC NT 25
Nominal pumping speed 50/60 Hz <sup>1)</sup>	m <sup>3</sup> · h <sup>-1</sup>	18.9/22.7	29.5/35.4
Pumping speed 50/60 Hz <sup>1)</sup>	m <sup>3</sup> · h <sup>-1</sup>	16.5/18.9	25.7/30.8
Ultimate partial pressure without gas ballast <sup>1)</sup>			
with mineral oil	mbar		10 <sup>-4</sup>
with PFPE	mbar		8 · 10 <sup>-4</sup>
Ultimate total pressure without gas ballast <sup>1)</sup>			
with mineral oil	mbar		< 2 · 10 <sup>-3</sup>
with DOT	mbar		0.6
Ultimate total pressure with gas ballast <sup>1)</sup>			
with mineral oil	mbar		5 · 10 <sup>-3</sup>
with PFPE	mbar		5 · 10 <sup>-3</sup>
with DOT	mbar		0.9
Water vapor tolerance <sup>1)</sup>	mbar		25
Water vapor capacity	g · h <sup>-1</sup>	305	476
Oil filling, min./max.	l	0.7 / 1.0	1.1 / 1.5
Noise level to DIN 45 635, (without gas ballast at 50 Hz)	dB (A)		< 54
Admissible ambient temperature	°C		12 - 40
Motor rating	W		550/660
Nominal speed	min <sup>-1</sup>		1500
Type of protection	IP	44 for single-phase motor / 55 for 3-phase motor	
Weight 3 ph / 1 ph motor	kg	35 / 40	41 / 46
Connections, intake and exhaust side	DN		25 KF

1) To DIN 28 400 ff

We can only guarantee that the pump will meet its specifications when using the type of lubricant which has been specified by us.

**Note**

# Description

## 1.3.1 Motor Related Data

Part No.	LN-No. 1 ph or 3 ph	Nominal voltage (V)	Frequency (Hz) ± 5%	Voltage range (V)	Power (kW)	Nominal (A) current	Size	Region
140 220	E 110 002 715 1 ph	95-120 / 190-252	50/60	+/- 5%	0.55	13.0 / 7.5	90	World
		95-120 / 190-242			0.66	10.0 / 5.0		
140 231, 140 232, 140 233, 140 234, 140 235	E 110 002 716 1 ph	218-242	50/60	+/- 5%	0.45/0.55	5.0 / 5.5	90	Euro
140 241	E 110 002 717 1 ph	95-105	50	+/- 5%	0.55	9.5	90	Japan/US
		95-120	60	+/- 5%	0.66	10.0		
140 221, 140 222, 140 223, 140 224, 140 225	E 110 002 712 3 ph	200-240 / 380-415 200-240 / 380-460	50 60	+/- 10% +/- 10%	0.55 0.66	3.1-4.0 / 1.5-1.6 3.1 / 1.6	90	World

### Related electrical equipment

If the pump has been approved for use in explosion hazard areas, then all electrical equipment like motor, valves, sensors, for example, is approved for operation in these areas (the same conditions as for the pump apply). Compliance with the enclosed operating information provided by the manufacturer of the electric motor needs to be ensured. When using other motors, these must be rated as follows:

Pumping speed / m <sup>3</sup>	16 / 25	16 / 25
Frequency / Hz	50	60
Speed / min	1500	1800
Power / W	750	750

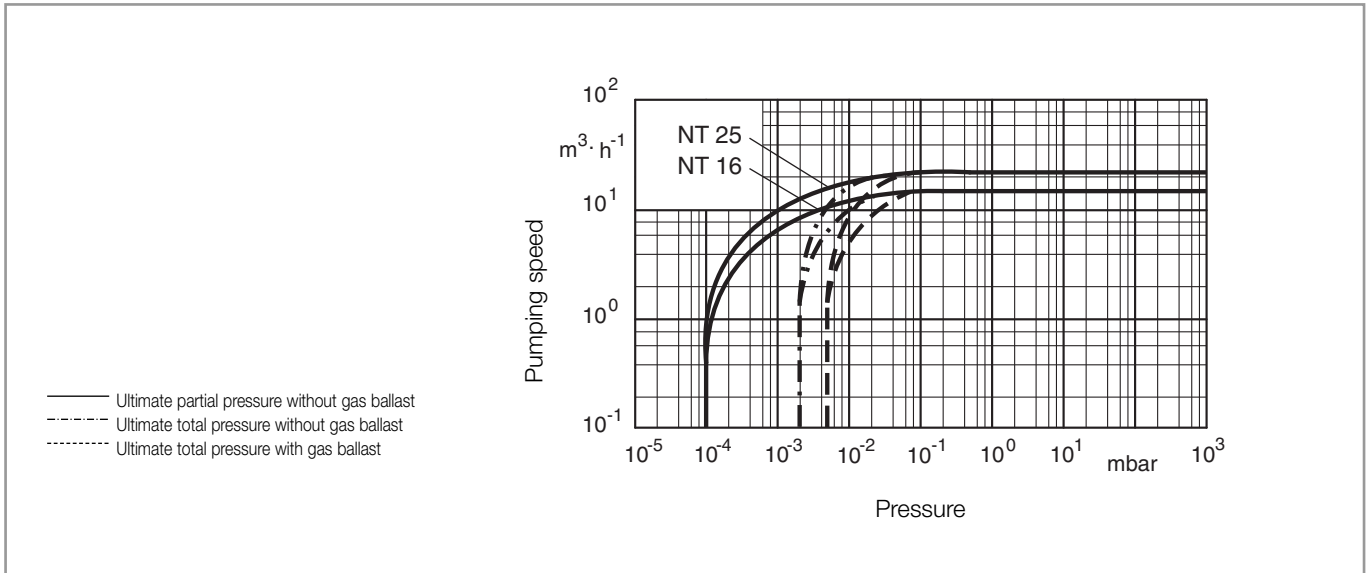

Fig. 1.5 Pumping speed characteristics of the TRIVAC NT 16 / NT 25

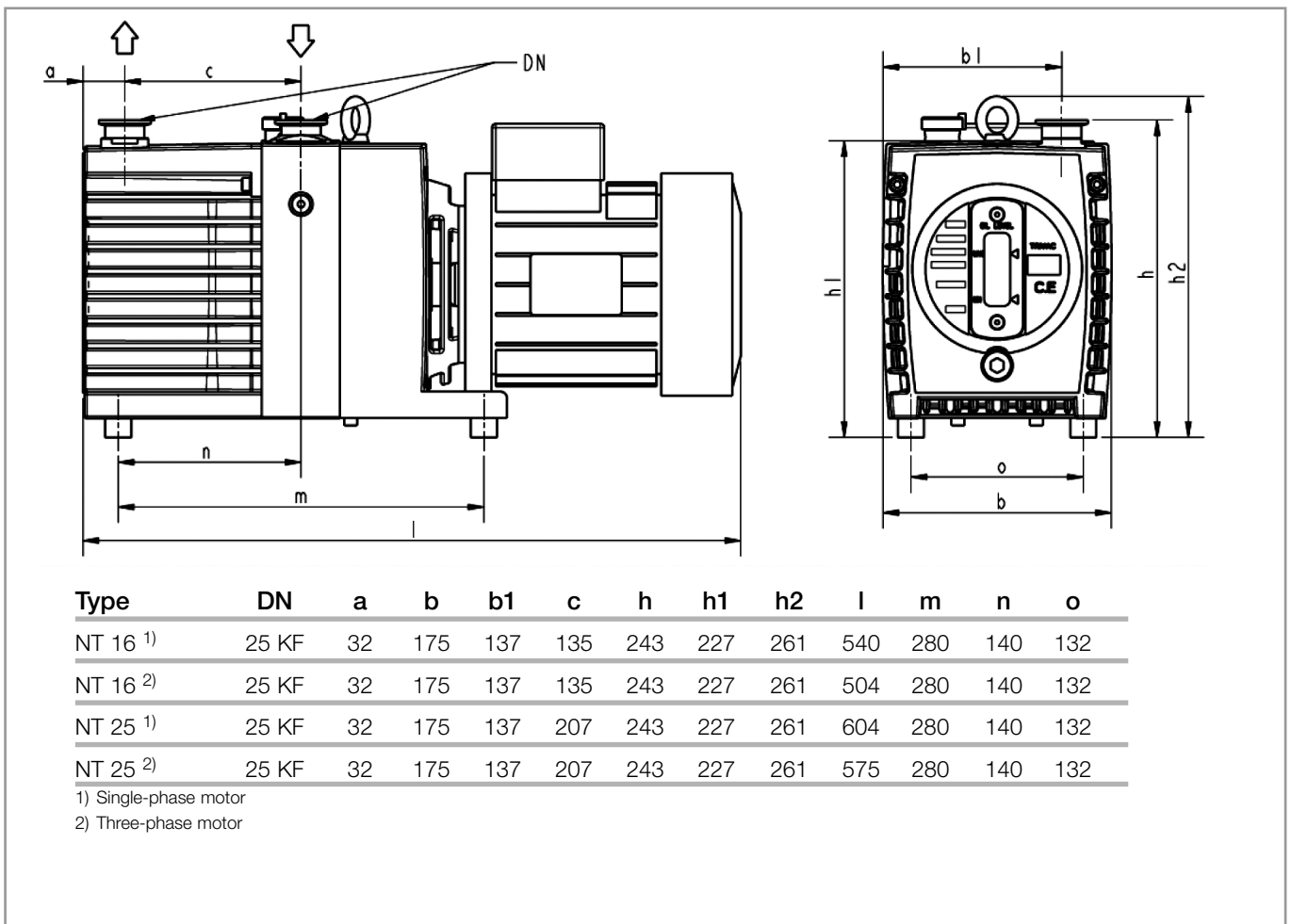

Fig. 1.6 Dimensional drawing; Dimensions in mm

# Description

## 1.4 Ordering Data

	<b>Part No.</b>
<b>TRIVAC NT 16</b>	
1-phase world motor, filling with N62	140 220
1-phase EU motor, filling with N62	140 231
1-phase EU motor, filling with GS 555	140 232
1-phase EU motor, filling with PFPE	140 233
1-phase EU motor, filling with DOT 4	140 234
1-phase EU motor, filling with RCF E 68N	140 235
1-phase US/Japan motor, filling with N62	140 241
3-phase world motor, filling with N62	140 221
3-phase world motor, filling with GS 555	140 222
3-phase world motor, filling with PFPE	140 223
3-phase world motor, filling with DOT 4	140 224
3-phase world motor, filling with RCF E 68N	140 225
<b>TRIVAC NT 25</b>	
1-phase world motor, filling with N62	140 330
1-phase EU/US motor, filling with N62	140 336
1-phase EU/US motor, filling with ANDEROL 555	140 337
1-phase EU/US motor, filling with PFPE	140 338
1-phase EU/US motor, filling with DOT 4	140 339
1-phase EU/US motor, filling with RCF E 68N	140 340
1-phase US/Japan motor, filling with N62	140 341
3-phase world motor, filling with N62	140 331
3-phase world motor, filling with ANDEROL 555	140 332
3-phase world motor, filling with PFPE	140 333
3-phase world motor, filling with DOT 4	140 334
3-phase world motor, filling with RCF E 68N	140 335
<b>Power supply cable for 1-phase world motor</b>	
100-120 V, 50/60 Hz; NEMA plug	140 304
100 V, 50/60 Hz; Plug for Japan	140 304V
200-240 V, 50/60 Hz; NEMA plug	140 305
200-240 V, 50/60 Hz; Schuko plug	
(Can also be used for 1-phase EU motor)	140 306
200-240 V, 50/60 Hz; Plug for United Kingdom (England)	
(Can also be used for 1-phase EU motor)	140 307

## 1.5 Accessories

Oerlikon Leybold accessories available for this pump, like inlet screen, for example, are also suited for operation in explosion hazard areas. The same conditions as for the pump apply.

When using other accessories with the pump, it needs to be ensured that these are suited for operation in explosion hazard areas.

---

### Caution

---

Accessories	Part No.
Exhaust filter AF 25	190 53
Exhaust filter	
AF 16-25	189 11 <sup>1)</sup>
AF 16-25 DOT	124 16 <sup>1)</sup>
Exhaust filter with lubricant return AR 16-25	189 21 <sup>1), 5)</sup>
Exhaust filter with lubricant return ARS 16-25	189 56 <sup>1), 5)</sup>
Condensate trap AK 25	190 63
Condensate trap AK 16-25	188 11 <sup>1) or 2)</sup>
Fine vacuum adsorption trap FA 8-16	187 10
Adsorption trap with aluminum oxide insert	854 15
Manually operated oil suction facility AR-M	190 93 <sup>4)</sup>
Oil suction facility AR-V controlled by solenoid valve	190 92 <sup>4)</sup>
Dust filter FS 8-16	186 10 <sup>2)</sup>
Dust separator AS 8-16	186 11
Mechanical oil filter OF 4-25	101 91 <sup>3)</sup>
Chemical oil filter CF 4-25	101 96 <sup>3)</sup>
Chemical oil filter with safety isolation valve CF 4-25	101 76 <sup>3)</sup>
Exhaust filter drain tap	190 95
Oil drain tap M 16 x 1.5, vacuum-tight	190 90
Oil drain kit	190 94
Inlet flange, horizontal	140 300
Exhaust flange, horizontal	140 301
Oil pressure switch with adapter	140 302
Adapter set for oil suction	140 298
Adapter set for oil filter	140 299
Oil level indicator (min.) ON/OFF switch	140 303

<sup>1)</sup> Use only together with the horizontal exhaust flange (Part No. 140 301) (FPM O-Ring)

**Caution:** For DOT use 2x EPDM-rings (Part No. 971 471 362)

<sup>2)</sup> Use only together with the horizontal intake flange (Part No. 140 300) (FPM O-Ring)

**Caution:** For DOT use 2x EPDM-rings (Part No. 971 468 772)

<sup>3)</sup> Can only be installed together with adapter 140 299

<sup>4)</sup> Can only be installed together with adapter 140 298

<sup>5)</sup> Can only be installed together with adapter set for oil suction part no. 140 308

# Transporting and Storing

Oils	Part No.
Mineral oil N62 1 l	177 01
5 l	177 02
20 l	177 03
GS 555, 1 l	200 10 272
SHC 224, 1 l	200 28 181
RCF-E 96 N, 1 l	200 39 839

Only use the kind of oil specified by Oerlikon Leybold Vacuum. Alternative types of oil are specified upon request.

## 2 Transportation and Storage

### Caution

Pumps which are filled with operating agents must only be moved while standing upright. Otherwise oil may escape. Avoid any other orientations during transport.

### Warning



Check the pump for the presence of any oil leaks, since there exists the danger that someone may slip on spilt oil.

When lifting the pump you must make use of the crane eyes provided on the pump for this purpose; also use the recommended type of lifting device.

Before putting a pump into operation once more it should be stored in a dry place preferably at room temperature (20 °C). Before the pump is shelved it must be properly disconnected from the vacuum system, purged with dry nitrogen and the oil should be changed too.

The inlets and outlets of the pump must be sealed with the shipping seals which are provided upon delivery.

The gas ballast switch must be set to the „0“ position and if the pump is to be shelved for a longer period of time it should be sealed in a PE bag containing some desiccant (silica gel).

When a pump is put into operation after it has been shelved for over one year, standard maintenance should be run on the pump and the oil should also be exchanged. We recommend that you contact the Oerlikon Leybold Vacuum Service.



## 3 Installation

### Installation requirements

- Install the pump such that only minimal quantities of dust can deposit themselves on the surfaces. In those cases where dust deposits form, measures need to be introduced which ensure that these are removed on a regular basis.
- The maximum gas inlet temperature must not exceed 60 °C.
- The maximum pressure at the inlet must not exceed atmospheric pressure (approximately 1013 mbar). Never apply overpressures to the pump's inlet.
- The maximum exhaust pressure must not exceed 0.5 bar (overpressure).
- If the pump (outside) has been certified for operation in areas with explosive atmospheres, the special information contained in the Operating Instructions for the electric motor for installation in explosive areas need to be complied with. Additional information is provided in the European standards EN 60079-14 "Electrical apparatus for explosive gas atmospheres Part - 14" and EN 60079-17 "Electrical apparatus for explosive gas atmospheres - Part 17".

### 3.1 Placement

Pumps marked as

 II (i) 3G IIC T4 (50 Hz/60 Hz) X

are **not** suited for installation in the explosion hazard areas.

Please note the change as to the Atex temperature class in the case of PFPE pumps. Suitability is restricted to T3 (gases and vapours with an ignition temperature of over 200 °C).

Pumps marked as

 II (i) 3G IIC T4 (50 Hz/60 Hz) X  
II (o) 3G IIC T3 (50 Hz/60 Hz) X

may only be used in Zone 2

DOT pumps are not suited for operation in explosion hazard areas or for pumping explosive substances.

The TRIVAC NT pump can be set up on a flat, horizontal surface. Rubber feet under the coupling housing ensure that the pump can not slip.

If the pump is to be installed permanently, then the threaded holes (M6) in the feet can be used to mount the pump. The rubber feet also act as vibration absorbers.

Max. tilt for the pump (without further attachment) with possibly fitted standard accessories is 10° from the vertical.

When installing the TRIVAC NT pump, make sure that the connections and controls are readily accessible.

---

### Warning



---

### Mounting the Pump

---

### Caution

---

# Installation

---

**Caution**

The site chosen should allow adequate air circulation to cool the pump (keep front and rear unobstructed).

The ambient temperature should not exceed +40 °C (104 °F) and not drop below +12 °C (55 °F) (see Section 4.4.3).

The max. amount of heat given off approximately corresponds to the rated motor power.

---

---

**Warning****3.2 Conforming Utilization**

When pumping toxic, chemical, radioactive and corrosive gases as well as pyrophorous substances, the operating company is under the obligation to comply with the national and international safety regulations and guidelines. Regarding the suitability of the TRIVAC NT pumps for special applications in which such gases, respectively substances shall be pumped, Oerlikon Leybold Vacuum should be consulted first. The pumps are not suited for pumping of liquids or media which carry large quantities of dust. Corresponding protection devices need to be provided.

---

**Caution**

The pumps are not suited for pumping liquids or media carrying significant quantities of dust. Provide corresponding protection facilities.

---

**Warning**

The standard pump is not suited for pumping of hazardous gases or vapours.

When cleaning a system in which a TRIVAC pump has been integrated, all parts in contact with the medium need to be compatible with the cleaning agent so as to prevent a chemical reaction. Residues of the cleaning agent within the pump must be avoided.

---

Our technical sales department is available for further advice in these matters.

**Responsibility of the operator**

Ensuring conforming utilisation of the TRIVAC pumps and compliance with the statutory requirements of the ATEX Operator Directive (99/92/EG) is the responsibility of the operator.

**Gas Composition**

It is important to note that the composition of the gas at the inlet of the pump and at the exhaust may possibly differ. This may possibly have effect on the zone divisions.

**Ignition Temperatures of Gases/Vapours**

Pumps with a fitted explosion hazard rated motor (category 3 i/o) for 50 Hz and 60 Hz operation are suited for applications in which potentially explosive gas or vapour mixtures exhibit an ignition temperature over T3 (200 °C) in explosion hazard areas (outside of the pump) in accordance with Zone 2.

The ignition temperatures of gases or vapours, sometimes also termed auto-ignition temperature can be taken from the material safety data sheets.

The pump is not suited for operation with reactive, aggressive or corrosive gases, or gases with an oxygen share exceeding 21% by volume.

## Potential Ignition Sources

An assessment of the ignition hazard was performed in accordance with the European standard EN 13463-1 (EN 13463-1 Non-electrical equipment for potentially explosive atmospheres - Part 1: Basic method and requirements). And based on this assessment the ignition sources listed in the following which may occur during operation of the pump, were determined:

Potential ignition sources	Remarks
Hot surfaces	Inside and outside due to gas compression, vane friction etc.
Hot gases	Are produced within the pump and ejected at the exhaust
Mechanical sparks	Will not occur during normal operation - the surfaces within the pump are covered with oil, sufficient clearances outside the pump
Electric sparks	Outside the pump due to motor, accessories
Static electricity	Possible, provided conducting parts of the pump are not connected to ground
Chemical reactions	Possible with the process liquid or the process gas

# Installation

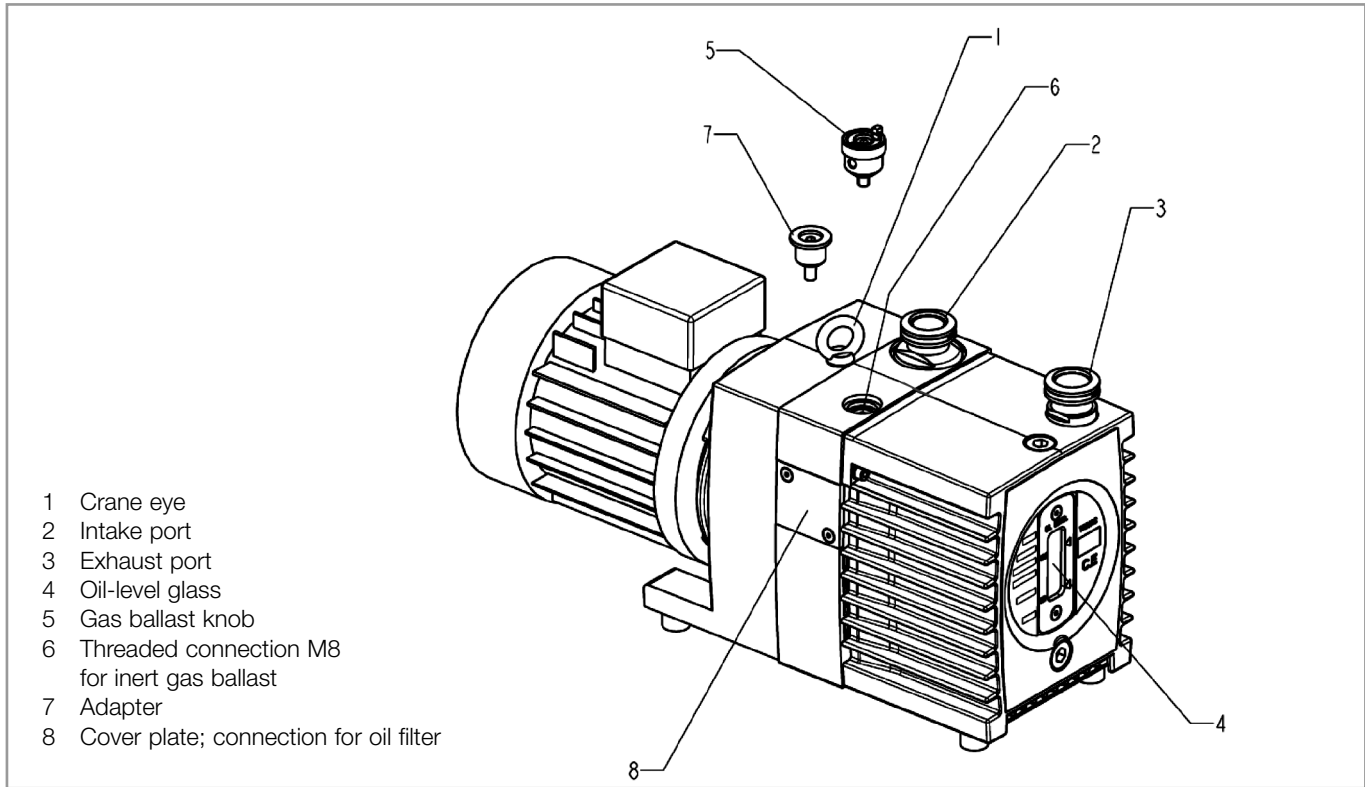

Fig. 3.1 Connections and controls

### 3.3 Connection to the System

Before connecting the TRIVAC NT, remove the shipping seals from the connection flanges (3.1/2) and (3.1/3).

---

**Note**

---

Retain the shipping seals in case you need to store the pump in the future.

The pump is shipped with intake and exhaust flanges for vertical connection of the connecting lines. It can be converted into horizontal connection. To do so, remove the flanges and mount the accessories for horizontal connection.

Connect the intake and exhaust lines with a centering ring and a clamping ring each. Use the centering ring with dirt trap for the intake port.

Connect the intake and exhaust line using anti-vibration bellows, without placing any strain on the pump.

The intake line must be clean. Deposits in the intake line may outgas and adversely affect the vacuum. The connecting flanges must be clean and undamaged.

The maximum throughput of the pump is equivalent to the pumping speed of the pump, see technical data.

The cross-section of the intake and exhaust lines should be at least the same size as the connection ports of the pump. If the intake line is too narrow, it reduces the pumping speed. If the exhaust line is too narrow, overpressures may occur in the pump; this might damage the shaft seals and cause oil leaks. The maximum pressure in the oil case must not exceed 1.5 bar (absolute).

When pumping vapours, it is advisable to install condensate traps on the intake and exhaust sides.

Install the exhaust line with a downward slope (lower than the pump) so as to prevent condensate from flowing back into the pump. If this is not possible, insert a condensate trap.

The exhaust gases from the vacuum pump must be safely led away and subjected to post-treatment as required. In order to reduce the emission of oil vapours we recommend the installation of an additional exhaust filter (Oerlikon Leybold Vacuum accessory).

Depending on the type of application or the kind of pumped media, the corresponding regulations and information sheets must be observed.

The pumps may be operated with an inert gas ballast via a connection which is provided for this purpose.

Inlet pressure for the gas ballast should be about 1000 mbar (absolute) and sufficient quantities of gas must be available (about  $\frac{1}{10}$  of the pumping speed).

Never operate the pump with a sealed exhaust line. There is the danger of injury.

Before starting any work on the pump, the personnel must be informed about possible dangers first. All safety regulations must be observed.

---

## Caution

---

## Inert gas ballast

---

## Warning



# Installation

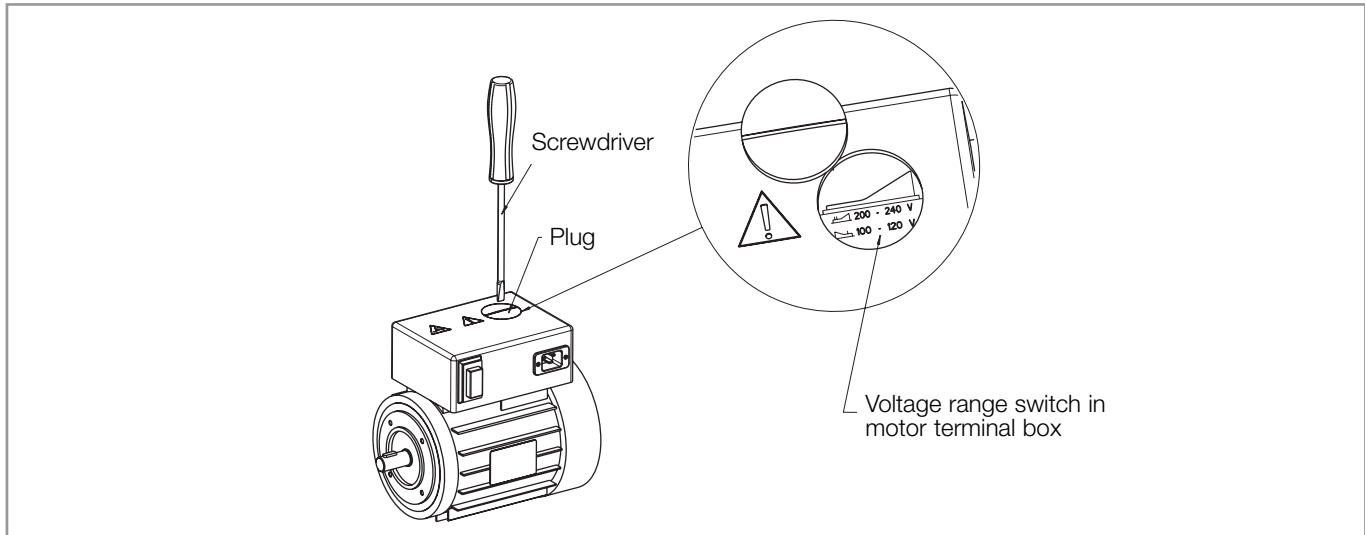

Fig. 3.2 Changing the voltage range at the 1 phase world motor

## 3.4 Electrical Connections

### Warning



Risk of suffering injury!

During all connection work, make sure that the mains cables have been reliably disconnected and do not carry a mains voltage. The electrical connections must only be provided by a trained electrician as specified, for example, by the regulations EN 50110-1.

In order to prevent the pump from running up unexpectedly after a mains power failure, the pump must be integrated in the control system in such a way that the pump can only be switched on again manually. This applies equally to emergency cut-out arrangements.

### Pump with Single-Phase AC Motor

The world motor is delivered for connection to 200 to 240 V. Change the voltage range if it is to be connected to 100 to 120 V. To do so, unscrew the plug at the motor terminal box, using a screwdriver. Change the switch setting. Screw the plug back in. We recommend to note the changed setting on the terminal box.

### Caution

The pump can be damaged if it is connected with a wrong voltage setting.

Pumps equipped with a single-phase AC motor may be connected directly to the mains via the mains cord and the mains plug.

Fusing must always be done in accordance with the national and local regulations for single phase mains (in Germany 16 amps, for example).

The direction of rotation need not be checked as it is fixed.

The motor is protected against overloading by a thermal overload switch with automatic resetting.

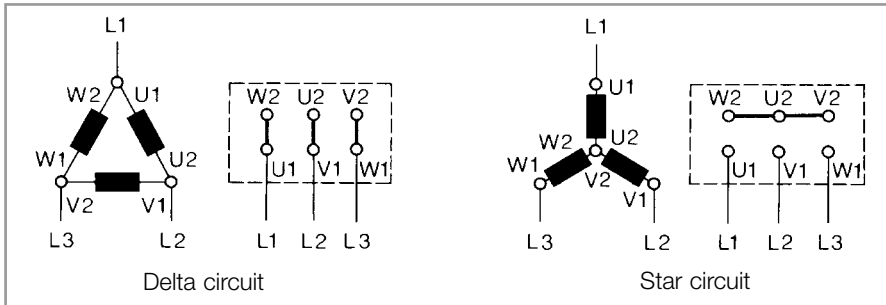

Fig. 3.3 Connection diagram for TRIVAC NT with 50/60 Hz 3-phase EUROPE / USA motor

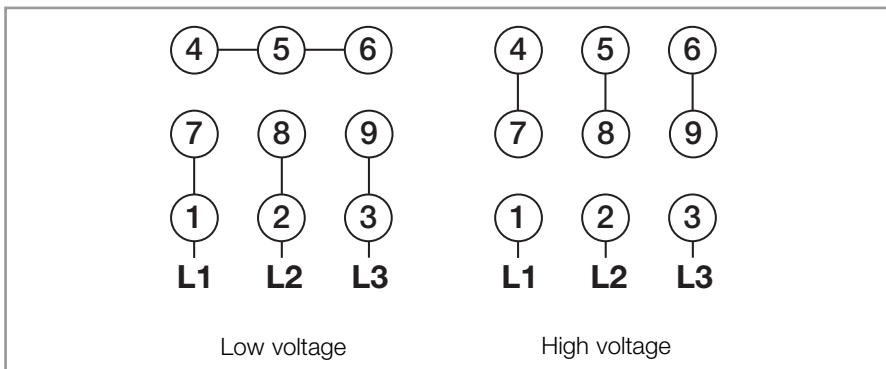

Fig. 3.4 Connection diagram for TRIVAC NT with 50/60 Hz 3-phase WORLD motor

If the thermal overload protector shuts off the pump, the motor will restart itself as soon as it cools. That's why the mains plug should be disconnected from the mains before starting with any work on the pump.

### Pump with Three-Phase AC Motor

TRIVAC NT pumps with a three-phase motor are supplied without accessories for electrical connection. They must be connected via the appropriate cable, and a suitable motor protection switch. Set the switch in accordance with the rating on the motor nameplate.

Fig. 3.3 shows the connection for pumps with:  
 230/400 V  $\pm$  10 %, 50 Hz  
 208-230 V  $\pm$  10 %, 60 Hz motors.

Fig. 3.4 shows the connection for pumps with:  
 200/240 / 380-415 V  $\pm$  10 %, 50 Hz  
 200/240 / 280-460 V  $\pm$  10 %, 60 Hz motors.

Please also observe the motor wiring diagram in the junction box and the information given on the nameplate of the motor.

After connecting the motor and after every time you alter the wiring, check the direction of rotation. To do so, briefly switch on the motor and check whether a suitable cover (e. g. a blank flange) is sucked on at the intake port. If not, interchange two phases of the connection. Observe the direction arrow on the coupling housing.

### Warning



### Caution

## 4 Operation

### 4.1 ATEX Directive and Flammable Gases Dilution

---

**Warning**



The TRIVAC NT 16 and 25 ATEX Category 3 pumps are designed according to the requirements of Directive 94/9/EEC Group II, Category 3.

These pumps are suited for operation under ATEX category 3 conditions corresponding to their respective part number and the special restrictions which apply for PFPE (for temperature class T3 only).

DOT pumps are not suited for operation in explosion hazard areas or for pumping explosive substances.

Never use a pump certified for Category 3 internal in an external potentially explosive atmosphere, as the pump is not designed with respect to potential ignition sources outside.

In the case of a potential external explosive atmosphere, use only pumps certified for the ignition category 3 inside and outside.

During normal operation there is no potential source of ignition inside and outside the pump but, according to the 94/9/EC directive, a rare malfunction may occur with potential sources of ignition.

In normal operation, even if the pump is designed for flammable gases, the operation procedure must ensure that the gases are not within their explosion limits.

When flammable gases are pumped, the following safety measures must be enforced:

- Prevent any atmospheric air from entering into the pump.
  - Use an inert gas to dilute the flammable gas being pumped; the concentration of flammable gas must not exceed 25% to 30% of the lower explosion limit.
-



## 4.2 Media Compatibility

Before pumping oxygen (or other highly reactive gases) at concentrations exceeding that of the atmosphere (> 21 % for oxygen), it is necessary to use a special pump. This special pump must be modified and degassed and a special lubricant (like PFPE) must be used.

When pumping toxic, chemical, radioactive and corrosive gases as well as pyrophorous substances, the operating company is under the obligation to comply with the national and international safety regulations and guidelines. Regarding the suitability of the TRIVAC NT pumps for special applications in which such gases, respectively substances shall be pumped, Oerlikon Leybold Vacuum should be consulted first.

The pumps are not suited for pumping liquids or very dusty media. Corresponding protection facilities need to be provided.

The pump is as standard not suited for pumping hazardous gases or vapours.

For inquiries, call our technical sales department.

## 4.3 Start Up

Check the oil level each time before switching on the pump.

When starting the pump up for the first time and each time changes are made to the electrical power supply connection, check the direction of rotation in the case of those pumps which are equipped with a three-phase motor (in accordance with Chapter 3.4).

During initial start up and after a longer period during which the pump has not been used, the pump may not immediately attain the specified ultimate pressure because the oil has to be degassed first. For this you should let the pump run for about 30 minutes with the intake line closed and the gas ballast valve (3.1/5) open.

Avoid exposing any part of the human body to the vacuum. There is the risk of suffering injury. Never operate the pump with an open intake port. Vacuum connections as well as oil feed and discharge openings must not be opened while the pump is operating.

The pressure in the oil box must not exceed 1.5 bar (absolute).

An exhaust line which is too small in diameter or which is blocked can result in the formation of overpressures within the pump. Possible consequences can be a damaged or even burst open pump. Thus the exhaust line must be checked from time to time to ensure that there are no obstructions.

---

### Warning



---

### Warning



## 4.4 Operation

TRIVAC NT pumps can pump condensable gases and vapours, provided that the gas ballast valve (3.1/5) is open and the pump has attained its operating temperature.

### 4.4.1 Pumping of Non-Condensable Gases and Vapours

If the process contains mainly permanent gases, the TRIVAC NT may be operated without gas ballast (position 0), provided that the saturation vapour pressure at operating temperature is not exceeded during compression.

If the composition of the gases to be pumped is not known and if condensation in the pump cannot be ruled out, run the pump with the gas ballast valve open in accordance with Section 4.4.2.

### 4.4.2 Pumping of Condensable Gases and Vapours

With the gas ballast valve open (position 2) and at operating temperature, TRIVAC NT pumps can pump pure water vapour up to the water vapour tolerance specified by the technical data. If the vapour pressure increases above the permissible level, the water vapour will condense in the oil of the pump.

When pumping vapours ensure that the gas ballast valve is open and that the pump has been warmed up for approximately 30 minutes with the intake line closed.

---

#### Caution

Vapour phases may only be pumped up to the permissible limit after the pump has attained its operating temperature.

During pumping, vapours may dissolve in the oil. This changes the oil properties and thus there is a risk of corrosion in the pump. Therefore, don't switch off the pump immediately after completion of the process. Instead, allow the pump to continue operating with the gas ballast valve open and the intake line closed until the oil is free of condensed vapours. We strongly recommend operating the TRIVAC NT in this mode for about 30 minutes after completion of the process.

In cyclic operation, the TRIVAC NT should not be switched off during the intervals between the individual working phases (power consumption is minimal when the pump is operating at ultimate pressure), but should continue to run with gas ballast valve open and intake port closed (if possible via a valve).

Once all vapours have been pumped off from a process (e.g. during drying), the gas ballast valve can be closed to improve the attainable ultimate pressure.

### 4.4.3 Operating Temperature

Proper operation of the TRIVAC NT is ensured in the ambient temperature range between 12 °C to 40 °C (55 °F to 104 °F).

At operating temperature, the surface temperature of the oil case may lie between 40 °C and over 70 °C (104 °F and 156 °F), depending on the load.

The surface temperature of the TRIVAC NT pumps may rise above 70 °C. There is the danger of receiving burns.

### 4.5 Shutdown

Under normal circumstances, all that you need do is to electrically switch off the TRIVAC NT.

No further actions will be required.

When pumping condensable media let the pump continue to operate with the gas ballast valve open and the intake line closed before switching off (see Section 4.4.2).

When pumping aggressive or corrosive media, let the pump continue to operate even during long non-working intervals (e.g. overnight) with the intake line closed and the gas ballast valve open. This avoids corrosion during idle periods.

If the TRIVAC NT is to be shutdown for an extended period after pumping aggressive or corrosive media or if the pump has to be stored, proceed as follows:

When having pumped harmful substances, take adequate safety precautions.

Drain the oil (see Section 5.4).

Add clean oil until the oil-level is at the „min“ mark and let the pump operate for some time.

Then drain the oil and add clean oil until the oil level is at the „max“ mark.

Seal the connection ports. Special conservation or anti-corrosion oils aren't necessary.

Please also take note of the information given in Section 2 (Storing).

---

#### Warning



---

#### Warning



# Operation

---

**Warning****Shutdown through Monitoring Components**

When the pump has been switched off due to overheating sensed by the motor coil protector or other monitoring components at the pump (e. g. thermal sensor), the pump must only be started manually after the pump has cooled down to the ambient temperature and after having removed the cause first.

---

**Warning****Controller/Mains Power Failure**

In order to prevent the pump from running up unexpectedly after a mains power failure, the pump must be integrated in the control system in such a way that the pump can only be switched on again manually. This applies equally to emergency cut-out arrangements.

## 5 Maintenance

Disconnect the electrical connections before disassembling the pump. Make absolutely sure that the pump cannot be accidentally started.

If the pump has pumped harmful substances, contrary to what has been stated in Section 4.2, ascertain the nature of hazard and take adequate safety measures.

Observe all safety regulations.

Due to the design concept, TRIVAC NT pumps require very little maintenance when operated under normal conditions.

All work must be carried out by suitably trained personnel. Maintenance or repairs carried out incorrectly will affect the life and performance of the pump and may cause problems when filing warranty claims.

Oerlikon Leybold Vacuum offers practical courses on the maintenance, repair, and testing of TRIVAC NT pumps. Further details are available on request.

If the TRIVAC NT is used in ambient air which is much contaminated, make sure that the air circulation and the gas ballast valve are not adversely affected.

Please take the spare parts numbers from the enclosed spare parts list.

In case of special designs and variants please always indicate the special, variant and serial number.

### 5.1 Oerlikon Leybold Vacuum Service

Whenever you send us in equipment, indicate whether the equipment is contaminated or is free of substances which could pose a health hazard. If it is contaminated, specify exactly which substances are involved. You must use the form we have prepared for this purpose.

A copy of the form has been reproduced at the end of these Operating Instructions: "Declaration of Contamination for Compressors, Vacuum Pumps and Components". Another suitable form is available from [www.oerlikon.com](http://www.oerlikon.com) → Oerlikon Leybold Vacuum → Documentation → Download Documents.

Attach the form to the equipment or enclose it with the equipment.

This statement detailing the type of contamination is required to satisfy legal requirements and for the protection of our employees.

We must return to the sender any equipment which is not accompanied by a contamination statement.

The pump must be packed in such a way, that it will not be damaged during shipping and so that any contaminants are not released from the package.

---

### Warning



### Contamination

### Form

---

### Warning



# Maintenance

## 5.2 Maintenance Plan (Recommendation)

No.	Rotary vane pump TRIVAC NT	Measurement/test quantity Operating/auxiliary materials	Interval						Remarks
			VE	VP	t	6m	a	n-a	
									Refer also to the Operating Instructions Section: individual components.
1	Operate the pump for at least 0.8 h with gas ballast.				x				Condensed water is thus removed from the oil.
2	Check the oil level, if required change the oil.	Mineral oil or special oils	x		x				Refill: Only after the pump has been switched off.
3	Check the quality of the oil, change the oil if required.	visually chemically mechanically	x		x		x	x	<b>Visually:</b> normally light and transparent, oil change is required when discolorations increase. <b>Chemically:</b> to DIN 51558, when the neutralisation number exceeds 2; then an oil change will be required. <b>Mechanically:</b> when dynamic viscosity at 25 °C exceeds 240 mPas; then an oil change will be required.
4	Clean the inlet screen in the intake port, change it as required.	Suitable cleaning agent and compressed air.				x			<ul style="list-style-type: none"> <li>■ Clean inlet screen with a cleaning agent and blow it out with compressed air under a suction hood.</li> <li>■ Replace the defective inlet screen.</li> </ul> Use a cleaning agent which complies with the national/international specifications. <b>Observe the safety regulations when using cleaning agents.</b>
5	Clean the internal demister, change it as required.	Suitable cleaning agent.						x	Already clean before the maintenance interval has elapsed when the noise level increases. <ul style="list-style-type: none"> <li>■ Clean internal demister with cleaning agent</li> <li>■ Replace the defective internal demister</li> <li>■ Dispose of the defective internal demister as special waste.</li> </ul> Cleaning agent according to national/international specifications. <b>Observe the safety regulations when using cleaning agents.</b>
6	Check the edges of the teeth on the coupling element for any damages, change the coupling element as required.							x	
7	Change the oil -  and  clean the oil level glass.	Mineral oil or special oils  Suitable cleaning agent and compressed air.						x	Oil change: <ul style="list-style-type: none"> <li>■ Annual or after 2000-3000 operating hours.</li> <li>■ Pump switched off</li> </ul> Pump cold or warm depending on pumped gases  Clean the oil level glass with a cleaning agent and blow it out with compressed air under a suction hood. <b>Use cleaning agents only corresponding to the national/international specifications.</b>
8	Check the fan of the pump and motor as well as the cooling fins on the motor for deposits and clean as required.	Brush and industrial vacuum cleaner.						x	Already clean before the maintenance interval has elapsed when the pump or the motor gets too warm. <b>Caution:</b> switch off the pump and ensure that it cannot run inadvertently (disconnect from the mains).

### Key to maintenance plan

VE = Maintenance before switching on  
the system  
VP = Maintenance before starting  
production  
t = Daily maintenance  
6m = Six monthly maintenance  
a = Annual maintenance  
n-a = Maintenance every n years

We recommend that you service the pump  
every two years covering the following:

- Cleaning
- Checking the individual components
- Exchange of all seals
- Functional check

This check should be run by the Oerlikon  
Leybold Vacuum Service.

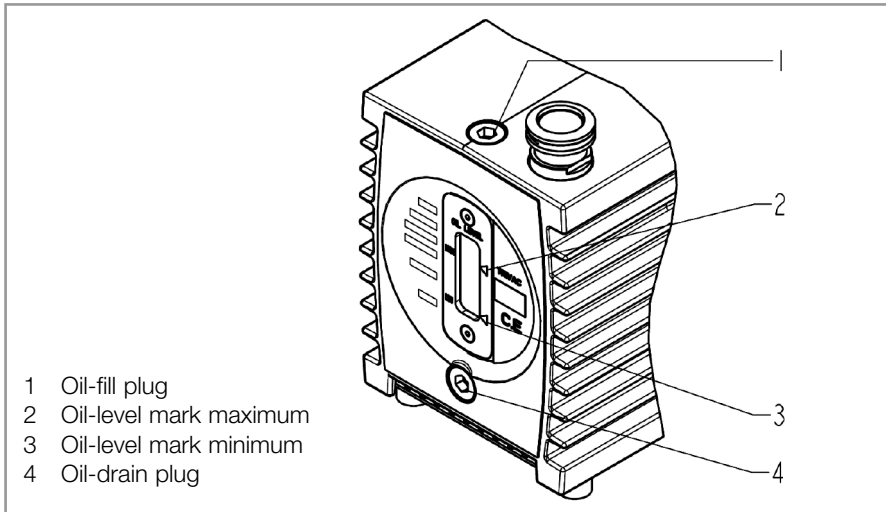

Fig. 5.1 Oil change

### 5.3 Checking the Oil

During operation of the TRIVAC NT the oil level must always remain between marks (5.1/2) and (5.1/3) on the oil-level glass. The amount of oil must be checked and topped up as required.

Fill in oil only after the pump has been switched off.

---

#### Caution

---

#### Checking the Condition of Mineral Oil

The ageing process for the oil will depend very much on the area of application for the pump.

##### a) Visual check

Normally the oil is clear and transparent. If the oil darkens, it should be changed.

##### b) Chemical check

The neutralisation number is determined according to DIN 51558. If it exceeds 2, the oil should be changed.

##### c) Viscosity check

If the viscosity at 25 °C exceeds a level of 240 mPas (20 % higher than the viscosity of fresh oil) an oil change is recommended.

If gases or liquids dissolved in the oil result in a deterioration of the ultimate pressure, the oil can be degassed by allowing the pump to run for approx. 30 min. with the intake port closed and the gas ballast valve open.

When wanting to check the oil, switch off the pump first and drain out from the warm pump the required amount of oil through the oil drain (5.1/4) into a beaker or similar.

Please note the safety information given in Section 5.

---

#### Warning



# Maintenance

## Checks at PFPE

PFPE are practically inert against any kind of chemical and oxidative influence. Against Lewis acids (like boron trifluoride  $\text{BF}_3$ , aluminium trichloride  $\text{AlCl}_3$ , for example) they are not entirely inert. Here a reaction at temperatures of approximately  $100\text{ }^\circ\text{C}$  or more can be expected.

PFPE are thermally highly stable. A thermal decomposition can occur only at temperatures over  $290\text{ }^\circ\text{C}$ .

---

### Warning



Perfluorinated polyethers will, when suffering thermal decomposition, release toxic and corrosive gases.

In the case of PFPE at least a visual check is recommended.

Normally the oil will be light and transparent. In the case of an increasing discoloration it is likely that the oil has taken up either liquid or solid process media, and an oil change is recommended.

---

## 5.4 Oil Change

### Warning



Before pumping oxygen (or other highly reactive gases) at concentrations exceeding the concentration in the atmosphere ( $> 21\%$  for oxygen) it will be necessary to use a special pump. Such a pump will have to be modified and degreased, and an inert special lubricant (like PFPE) must be used.

Hazardous substances may escape from the pump and the oil. Take adequate safety precautions. For example wear gloves, face protection or breathing protection.

Observe all safety regulations.

---

## Mineral oil

For proper operation of the pump, it is essential that the pump has an adequate supply of the correct and clean oil at all times.

The oil must be changed when it looks dirty or if it appears chemically or mechanically worn out, see Section 5.3.

The oil should be changed after 2000 - 3000 operating hours or after one year. At high intake pressures and intake temperatures and/or when pumping contaminated gases, the oil will have to be changed much more frequently.

Further oil changes should be made before and after long-term storage of the pump.

If the oil becomes contaminated too quickly, install a dust filter and/or oil filter (see Section 1.5).

Contact us for more information in this matter.



Change the oil while the pump is cold so as to avoid releasing adsorbed gases. If releasing adsorbed gases is no problem, change the oil after the pump has been switched off and while the pump is still warm.

---

## Caution

---

### PFPE

PFPE lubricants are chemically almost inert. Thus they do not suffer ageing like mineral oils, for example.

However, PFPE lubricants offer a reduced dispersing behaviour compared to that of mineral oils. For this reason, any contaminant particles entering into the pump may deposit themselves within the pump and cause damage. The ingress of process media can also cause impairments within the pump, for example through condensation and a reduction in the attainable ultimate pressure or by attacking components through aggressive media. In this case pumps with a filling of PFPE must always be operated in connection with a suitable oil filter facility.

When the oil filter facilities are changed early enough, it will only be required to exchange the PFPE rarely. In such cases we recommend to exchange the PFPE once a year to be on the safe side.

Shorter oil change intervals will be necessary in the case of

- inadequate oil filter facilities
- oil filter changes which are done too late
- when pumping contaminated gases
- when pumping extremely reactive substances.

How often a PFPE exchange will be necessary can only be decided on a case-by-case basis depending on the level and type of contamination.

**Required tool:** Allen key 8 mm.

Remove the oil-drain plug (5.1/4) and let the used oil drain into a suitable container. When the flow of oil slows down, screw the oil-drain plug back in, briefly switch on the pump (max. 10 s) and then switch it off again. Remove the oil-drain plug once more and drain out the remaining oil.

Screw the oil-drain plug back in (check the gasket and reinstall a new one if necessary).

Remove the oil-fill plug (5.1/1) and fill in with fresh oil.

Screw the oil-fill plug (5.1/1) back in.

If there is the danger that the operating agent may present a hazard in any way due to decomposition of the oil, or because of the media which have been pumped, you must determine the kind of hazard and ensure that all necessary safety precautions are taken.

---

## Warning

---



# Maintenance

Torque for the oil-fill plug and oil-drain plug: 10 Nm

Gasket: P/N: 239 55 165

We can only guarantee that the pump operates as specified by the technical data if the lubricants recommended by us are used.

## 5.5 Cleaning the Inlet Screen

A wire-mesh sieve is located in the intake port of the pump to act as a dirt trap for coarse particles. It should be kept clean to avoid a reduction of the pumping speed.

For this purpose, remove the inlet screen (1.2/2) from the intake port and rinse it in a suitable vessel with solvent. Then thoroughly dry it with compressed air. If the inlet screen is defective, replace it with a new one.

The cleaning intervals depend on the application. If the pump is exposed to large amounts of abrasive materials, a dust filter should be fitted into the intake line.

## 5.6 Checking the Coupling

Here the backlash between coupling cams and the flexible spider must be checked by a feeler gauge (see sketch 1).

When reaching the limit of **wear of max.** friction, the spider must be exchanged immediately, independent of the inspection intervals.

### The wear limit is at 3 mm!

In addition a visual inspection as to the presence of any damage needs to be done. If damaged, the coupling must be replaced.

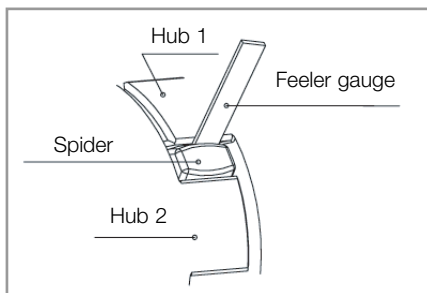

Sketch 1 Checking the wear limit

## 5.7 Replacing the Outer Shaft Seal

### Required tools:

Allen keys 3 mm, 5 mm, 8 mm, flat-nose pliers, plastic hammer, shaft seal driver, possibly puller for coupling.

The TRIVAC NT has two shaft seals; the outer one is subject to greater wear. Oil marks under the coupling housing are signs of a damaged outer shaft seal.

The outer shaft seal (5.2/8) can be replaced without removing or disassembling the pump module.

Shutdown the pump.

Drain the oil (see Section 5.2) or place the pump on its front side.

Unscrew the four not counter-sunk hexagon socket screws at the intermediate flange and detach the motor with the intermediate flange.

Remove the coupling element (5.2/1).

Remove the hex. socket screw (5.2/2) and the spring washer (5.2/3).

Pull off the coupling (5.2/4). Remove the key (5.2/5).

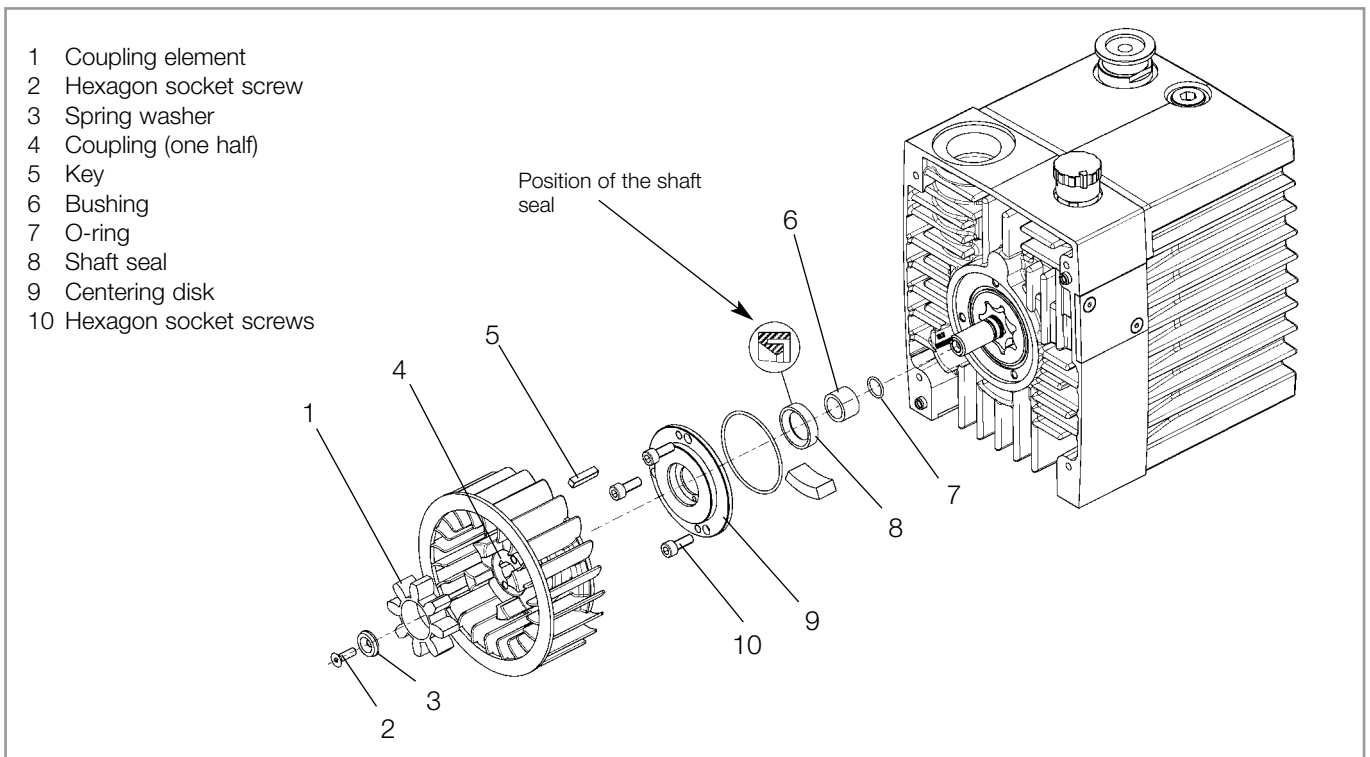

Fig. 5.2 Exchanging the outer shaft seal

Unscrew the hex. socket screws (5.2/10) and pull off the centering disk (5.2/9).

If the centering disk is stuck, screw the capscrews (5.2/10) into the jackscrew holes in the centering disk.

Carefully force the shaft seal (5.2/8) out of the centering disk.

Carefully pull off the bushing (5.2/6) from the shaft and remove the O-ring (5.2/7).

We recommend the use of a new shaft seal, an O-ring and bushing for reassembly.

Before insertion, moisten the new shaft seal slightly with a little vacuum pump oil.

Using a suitable plastic or aluminium cylinder (shaft seal driver) and a plastic hammer, force the shaft seal (5.2/8) carefully and without bending it into the centering disk (for position of shaft seal, see Fig. 5.2).

If you do not have a shaft seal driver, place the shaft seal on the centering disk and carefully force it in with light blows of the plastic hammer.

The shaft seal must not be bent.

Carefully push the O-ring (5.2/7) and the bushing (5.2/6) onto the shaft.

Push the centering disk (5.2/1) with the shaft seal onto the shaft and up against the end plate; fasten it with the hex. socket screws (5.2/10).

# Maintenance

Insert the key (5.2/5).

Check the coupling, replace if required. To check the coupling note the information provided in Section 5.6.

Mount the pump-half of the coupling (5.2/4) on the shaft.

Install the spring washer (5.2/3) and tighten the screw (5.2/2).

Insert the coupling element (5.2/1) into the coupling and mount the motor.

# Troubleshooting

## 6 Troubleshooting

Fault	Possible cause	Remedy	Repair*
Pump does not start.	Wiring is malfunctioning.	Check and repair wiring.	-
	Motor protection switch incorrectly set (three-phase motors only).	Set motor protection switch properly.	3.4
	Operating voltage does not match motor.	Replace the motor.	-
	Motor is malfunctioning.	Replace the motor.	-
	Oil temperature is below 12 °C.	Heat the pump and pump oil or use a different oil.	4.4.3/1.5
	Oil is too thick.	Change the oil.	5.4
	Exhaust filter/exhaust line is clogged.	Replace the filter or clean the exhaust line.	-
	Pump is seized up (sign: pump is jammed).	Repair the pump.	Service
Pump does not reach ultimate pressure.	Measuring technique or gauge is unsuitable.	Use correct measuring technique and gauge. Measure the pressure directly at the pump's intake port.	-
	External leak <sup>1)</sup> .	Repair the pump.	Service
	Anti-suckback valve is malfunctioning.	Repair the valve.	Service
	Exhaust valve is malfunctioning.	Repair the valve.	Service
	Oil is unsuitable.	Change the oil (degas it, if necessary).	5.4
	Vacuum lines are dirty.	Clean the vacuum lines.	-
	Pump is too small.	Check the process data, replace the pump, if necessary.	-
Pumping speed is too low.	Inlet screen in the intake port is clogged.	Clean the inlet screen. Precaution: install a dust filter in the intake line.	5.5
	Exhaust filter is clogged.	Install new filter element.	-
	Connecting lines are too narrow or too long.	Use adequately wide and short connecting lines.	3.3
After switching off the pump under vacuum, pressure in the system rises too fast.	System has a leak.	Check the system.	-
	Anti-suckback valve is malfunctioning.	Repair the valve.	Service

\* Repair: Refer to the stated section in these Operating Instructions.

1) Bubble test: The warm pump with degassed oil is running without gas ballast and the intake is blanked off. The exhaust line is led into a vessel with water. If an evenly spaced line of bubbles appears then the pump has an external leak.

# Troubleshooting

Fault	Possible cause	Remedy	Repair
Pump gets hotter than usually observed.	Cooling air supply is obstructed.	Set pump up correctly.	3.1
	Ambient temperature is too high.	Set pump up correctly.	3.1/4.4.3
	Process gas is too hot.	Change the process.	-
	Oil level is too low.	Add oil.	5.3
	Oil is unsuitable.	Change the oil.	5.4
	Oil cycle is obstructed.	Clean or repair the oil lines and channels.	Service
	Exhaust filter/exhaust line is obstructed.	Replace the exhaust filter, clean the exhaust line.	-
	Exhaust valve is malfunctioning.	Repair the valve.	Service
	Pump module is worn out.	Replace the pump module.	Service
Deviating mains voltage.	Check the motor voltage and check available mains voltage.	-	
Oil in the intake line or in the vacuum vessel.	Oil comes from the vacuum system.	Check the vacuum system.	-
	Anti-suckback valve is blocked.	Clean or repair the anti-suckback valve.	Service
	Sealing surfaces of the anti-suckback valve are damaged or dirty.	Clean or repair intake and anti-suckback valve	Service
	Oil level is too high.	Drain out excess oil.	5.3
Oil is turbid.	Condensation.	Degas the oil or change the oil and clean the pump. Precaution: open the gas ballast valve or fit separator.	4.4.2/5.4
Pump is excessively noisy.	Oil level is much too low (oil level is no longer visible).	Add oil.	5.3/5.4
	Silencing nozzle is clogged.	Clean the silencing nozzle or replace it.	Service
	Intake pressure is too high.	Lower the intake pressure.	-
	Internal demister is clogged.	Clean or replace demister.	Service
	Coupling element is worn.	Install new coupling element.	-
	Vanes or bearings are damaged.	Repair pump.	Service
Pump shuts down after a few minutes with very high motor temperature or with a very high current uptake (> 15 A).	Relay does not switch off the start-up capacitor	Let the motor cool down (for at least 10 minutes).	-
	(Voltage too low).	Ensure correct power supply voltage (218-242 V).	-

## 7 Wearing and Original Parts

<b>NT 16 / NT 25</b>	<b>Part No.</b>
Spare parts kit for shaft sealing ring replacement (includes all necessary gaskets and small parts)	EK110002700
Spare parts kit for gas ballast (gas ballast body and metal disk)	EK110002720

<b>NT 16</b>	<b>Part No.</b>
Small maintenance kit for simple maintenance (includes all necessary gaskets, no oil)	EK110002701
Large maintenance kit (includes all necessary wearing parts and spare parts for major maintenance, no oil)	EK110002702
Small parts kit	EK110002703
Replacement pump module	EK110002704

<b>NT 25</b>	<b>Part No.</b>
Small maintenance kit for simple maintenance (includes all necessary gaskets, no oil)	EK110002775
Large maintenance kit (includes all necessary wearing parts and spare parts for major maintenance, no oil)	EK110002776
Small parts kit	EK110002777
Replacement pump module	EK110002778

# Disposal

## Contamination

### Warning



## 8 Waste Disposal

The equipment may have been contaminated by the process or by environmental influences. In this case the equipment must be decontaminated in accordance with the relevant regulations. We offer this service at fixed prices. Further details are available on request.

Contaminated parts can be detrimental to health and environment. Before beginning with any work, first find out whether any parts are contaminated. Adhere to the relevant regulations and take the necessary precautions when handling contaminated parts.

Separate clean components according to their materials, and dispose of these accordingly. We offer this service. Further details are available on request.

When sending us any equipment, observe the regulations given in Section "5.1 Oerlikon Leybold Vacuum Service".

### Disposal of Waste Oil

Owners of waste oil are entirely self-responsible for proper disposal of this waste.

Waste oil from vacuum pumps must not be mixed with other substances or materials.

Waste oil from vacuum pumps (Oerlikon Leybold Vacuum oils which are based on mineral oils) which are subject to normal wear and which are contaminated due to the influence of oxygen in the air, high temperatures or mechanical wear must be disposed of through the locally available waste oil disposal system.

Waste oil from vacuum pumps which is contaminated with other substances must be marked and stored in such a way that the type of contamination is apparent. This waste must be disposed of as special waste.

European, national and regional regulations concerning waste disposal need to be observed. Waste must only be transported and disposed of by an approved waste disposal vendor.

Waste disposal key for **DOT**: + 55256 x

**PFPE** from vacuum pumps may be regenerated, if required, and provided the quantities are large enough. For this, please contact us for assistance.



## EC Declaration of Conformity

We, Oerlikon Leybold Vacuum GmbH, hereby declare that the products specified and listed below which we have placed on the market, comply with the applicable EC Council Directives.

This declaration becomes invalid if modifications are made to the product without agreement of Oerlikon Leybold Vacuum GmbH.

Compliance with the EMC Directives requires that the components are installed within a system or machine in a manner adapted to EMC requirements.

**Designation of the products:** Rotary vane vacuum pump

**Model:** TRIVAC NT 16, TRIVAC NT 25

**Part-No.:** 140220 to 140241, 140330 to 140341

**The product complies to the following European Council Directives:**

- EC-Machinery Directive (98/37/EC)
- EC-Directive related to electrical equipment designed for use within certain voltage limits (2006/95/EC)
- EC-Directive relating to electromagnetic compatibility (2004/108/EC)
- EC-Directive relating to explosive atmospheres (ATEX Directive – Category 3G)  
Equipment intended for use in potentially explosive atmospheres – Internal atmospheres only (94/9/EG)

**Related, harmonized standards:**

- EN 1012-2,  
Safety requirements for compressors and vacuum pumps  
Part 2: Vacuum pumps
- EN 60034-1,  
Rotating electrical machines  
Part 1: Rating and performance
- EN 60204-1,  
Safety of machinery - Electrical equipment of machines  
Part 1: General requirements
- EN 13463-1,  
Non electric apparatus for use in explosive atmospheres (Category 3G)  
Non electrical equipment for use in potentially explosive atmospheres

Valence, November 17<sup>th</sup>, 2008



---

Joseph Schott  
Plant Manager

Valence, November 17<sup>th</sup>, 2008



---

Jean-Luc Abraham  
Technical Director

**Oerlikon Leybold Vacuum France**  
640, rue Aristide Berges – BP107  
F-26501 BOURG-LES-VALENCE cédex  
Tel.: +33-(0)4.75.82.33.00  
Fax: +33-(0)4.75.8292.69

[www.oerlikon.com/leyboldvacuum](http://www.oerlikon.com/leyboldvacuum)

### Declaration of Contamination of Compressors, Vacuum Pumps and Components

The repair and / or servicing of compressors, vacuum pumps and components will be carried out only if a correctly completed declaration has been submitted. **Non-completion will result in delay.** The manufacturer can refuse to accept any equipment without a declaration.

**A separate declaration has to be completed for each single component.**

This declaration may be completed and signed only by authorised and qualified staff.

Customer/Dep./Institute: _____	<b>Reason for return</b> <input checked="" type="checkbox"/> applicable please mark
Address: _____	<input type="checkbox"/> <b>Repair</b> <input type="checkbox"/> chargeable <input type="checkbox"/> warranty
Person to contact: _____	<input type="checkbox"/> <b>Exchange</b> <input type="checkbox"/> chargeable <input type="checkbox"/> warranty
Phone: _____ Fax: _____	<input type="checkbox"/> exchange already arranged / received
End user: _____	<b>Return only:</b> <input type="checkbox"/> rent <input type="checkbox"/> loan <input type="checkbox"/> for credit
	<b>Calibration:</b> <input type="checkbox"/> DKD <input type="checkbox"/> Factory calibration
	<input type="checkbox"/> Quality test certificate DIN 55350-18-4.2.1

<b>A. Description of the Leybold product</b>	Failure description: _____
Material description: _____	_____
Catalog number: _____	Additional parts: _____
Serial number: _____	Application Tool: _____
Type of oil (Forevacuum pumps): _____	Application Process: _____

<b>B. Condition of the equipment</b>						
	No <sup>1)</sup>	Yes	No	<b>Contamination:</b>	No <sup>1)</sup>	Yes
1. Has the equipment been used <sup>1)</sup>	<input type="checkbox"/>	<input type="checkbox"/>	<input checked="" type="checkbox"/>	toxic	<input type="checkbox"/>	<input type="checkbox"/>
2. Drained (Product/service fluid)	<input checked="" type="checkbox"/>	<input type="checkbox"/>	<input type="checkbox"/>	corrosive	<input type="checkbox"/>	<input type="checkbox"/>
3. All openings sealed airtight	<input checked="" type="checkbox"/>	<input type="checkbox"/>	<input type="checkbox"/>	flammable	<input type="checkbox"/>	<input type="checkbox"/>
4. Purged	<input checked="" type="checkbox"/>	<input type="checkbox"/>	<input type="checkbox"/>	explosive <sup>2)</sup>	<input type="checkbox"/>	<input type="checkbox"/>
If yes which cleaning agent: _____				radioactive <sup>2)</sup>	<input type="checkbox"/>	<input type="checkbox"/>
and which method of cleaning: _____				microbiological <sup>2)</sup>	<input type="checkbox"/>	<input type="checkbox"/>
<sup>1)</sup> if answered with "No" go to <b>D.</b>				other harmful substances	<input type="checkbox"/>	<input type="checkbox"/>

<b>C. Description of processed substances (Please fill in absolutely)</b>	
1. What substances have come into contact with the equipment: Trade name and / or chemical term of service fluids and substances processed, properties of the substances; According to safety data sheet (e.g. toxic, inflammable, corrosive, radioactive)	
Tradename: _____	Chemical name: _____
a) _____	
b) _____	
c) _____	
d) _____	
2. Are these substances harmful?	No Yes
	<input type="checkbox"/> <input type="checkbox"/>
3. Dangerous decomposition products when heated?	No Yes
	<input type="checkbox"/> <input type="checkbox"/>
If yes, which? _____	

**<sup>2)</sup> Components contaminated by microbiological, explosive or radioactive products/substances will not be accepted without written evidence of decontamination.**

<b>D. Legally binding declaration</b>	
<b>I / we hereby declare that the information supplied on this form is accurate and sufficient to judge any contamination level.</b>	
Name of authorised person (block letters): _____	
Date _____	Signature of authorised person _____
	<div style="border: 1px dashed black; width: 150px; height: 40px; margin-left: auto;"></div> firm stamp



# Sales and Service

## Germany

**Oerlikon**  
**Leybold Vacuum GmbH**  
Bonner Strasse 498  
D-50968 Cologne  
Phone: +49-(0)221-347 1234  
Fax: +49-(0)221-347 1245  
sales.vacuum@oerlikon.com  
www.oerlikon.com

**Oerlikon**  
**Leybold Vacuum GmbH**  
**Sales Area North/Northeast**  
Branch Office Berlin  
Industriestrasse 10b  
D-12099 Berlin  
Phone: +49-(0)30-435 609 0  
Fax: +49-(0)30-435 609 10  
sales.vacuum.bn@oerlikon.com

**Oerlikon**  
**Leybold Vacuum GmbH**  
**Sales Area South/Southwest**  
Branch Office Munich  
Karl-Hammerschmidt-Strasse 34  
D-85609 Aschheim-Dornach  
Phone: +49-(0)89-357 33 9-10  
Fax: +49-(0)89-357 33 9-33  
sales.vacuum.mn@oerlikon.com  
service.vacuum.mn@oerlikon.com

**Oerlikon**  
**Leybold Vacuum GmbH**  
**Sales Area West & Benelux**  
Branch Office Cologne  
Bonner Strasse 498  
D-50968 Cologne  
Phone: +49-(0)221-347 1270  
Fax: +49-(0)221-347 1291  
sales.vacuum.kn@oerlikon.com

**Oerlikon**  
**Leybold Vacuum GmbH**  
**Service Competence Center**  
Emil-Hoffmann-Strasse 43  
D-50996 Cologne-Suerth  
Phone: +49-(0)221-347 1439  
Fax: +49-(0)221-347 1945  
service.vacuum.kn@oerlikon.com

**Oerlikon**  
**Leybold Vacuum GmbH**  
**Mobil Customer Service**  
Emil-Hoffmann-Strasse 43  
D-50996 Cologne-Suerth  
Phone: +49-(0)221-347 1765  
Fax: +49-(0)221-347 1944  
service.vacuum.kn@oerlikon.com

**Oerlikon**  
**Leybold Vacuum**  
**Dresden GmbH**  
**Service Competence Center**  
Zur Wetterwarte 50, Haus 304  
D-01109 Dresden  
Service:  
Phone: +49-(0)351-88 55 00  
Fax: +49-(0)351-88 55 041  
info.vacuum.dr@oerlikon.com

**Oerlikon**  
**Leybold Vacuum USA Inc.**  
5700 Mellon Road  
USA-Export, PA 15632  
Phone: +1-724-327-5700  
Fax: +1-724-325-3577  
info.vacuum.ex@oerlikon.com

## Europe

Belgium  
**Oerlikon**  
**Leybold Vacuum Nederland B.V.**  
**Belgisch bijkantoor**  
Leuvensesteenweg 542-9A  
B-1930 Zaventem  
Sales:  
Phone: +32-2-711 00 83  
Fax: +32-2-720 83 38  
sales.vacuum.zv@oerlikon.com  
Service:  
Phone: +32-2-711 00 82  
Fax: +32-2-720 83 38  
service.vacuum.zv@oerlikon.com

France  
**Oerlikon**  
**Leybold Vacuum France S.A.**  
7, Avenue du Québec  
Z.A. de Courtaboeuf 1 - B.P. 42  
F-91942 Courtaboeuf Cedex  
Sales and Service:  
Phone: +33-1-69 82 48 00  
Fax: +33-1-69 07 57 38  
info.vacuum.ctb@oerlikon.com  
sales.vacuum.ctb@oerlikon.com

**Oerlikon**  
**Leybold Vacuum France S.A.**  
**Valence Factory**  
640, Rue A. Bergès  
B.P. 107 640  
F-26501 Bourg-lès-Valence Cedex  
Service:  
Phone: +33-4-75 82 33 00  
Fax: +33-4-75 82 92 69  
marketing.vacuum.vc@oerlikon.com

Great Britain  
**Oerlikon**  
**Leybold Vacuum UK LTD.**  
Silverglade Business Park  
Leatherhead Road Unit 2  
KT9 2QL Chessington, Surrey  
(London)  
Sales:  
Phone: +44-13-7273 7300  
Fax: +44-13-7273 7301  
sales.vacuum.ln@oerlikon.com  
Service:  
Phone: +44-20-8971 7030  
Fax: +44-20-8971 7003  
service.vacuum.ln@oerlikon.com

Italy  
**Oerlikon**  
**Leybold Vacuum Italia S.r.l.**  
Via Trasimeno 8  
I-20128 Milano  
Sales:  
Phone: +39-02-27 22 31  
Fax: +39-02-27 20 96 41  
sales.vacuum.mi@oerlikon.com  
Service:  
Phone: +39-02-27 22 31  
Fax: +39-02-27 22 32 17  
service.vacuum.mi@oerlikon.com

Netherlands  
**Oerlikon**  
**Leybold Vacuum Nederland B.V.**  
Proostwetering 24N  
NL-3543 AE Utrecht  
Sales and Service:  
Phone: +31-(30) 242 6330  
Fax: +31-(30) 242 6331  
sales.vacuum.ut@oerlikon.com  
service.vacuum.ut@oerlikon.com

Spain  
**Oerlikon**  
**Leybold Vacuum Spain, S.A.**  
C/ Huelva 7  
E-08940 Cornellà de Llobregat  
(Barcelona)  
Sales:  
Phone: +34-93-666 43 11  
Fax: +34-93-666 43 70  
sales.vacuum.ba@oerlikon.com  
Service:  
Phone: +34-93-666 46 16  
Fax: +34-93-685 43 70  
service.vacuum.ba@oerlikon.com

Sweden  
**Oerlikon**  
**Leybold Vacuum Scandinavia AB**  
Box 9084  
SE-40092 Göteborg  
Sales and Service:  
Phone: +46-31-68 84 70  
Fax: +46-31-68 39 39  
info.vacuum.gt@oerlikon.com  
sales.vacuum.gt@oerlikon.com  
Visiting/delivery address:  
Datavägen 57B  
SE-43632 Askim

Switzerland  
**Oerlikon**  
**Leybold Vacuum Schweiz AG**  
Leutschenbachstrasse 55  
CH-8050 Zürich  
Sales:  
Phone: +41-44-308 40 50  
Fax: +41-44-302 43 73  
sales.vacuum.zh@oerlikon.com  
Service:  
Phone: +41-44-308 40 62  
Fax: +41-44-308 40 60  
service.vacuum.zh@oerlikon.com

## America

USA  
**Oerlikon**  
**Leybold Vacuum USA Inc.**  
5700 Mellon Road  
USA-Export, PA 15632  
Phone: +1-724-327-5700  
Fax: +1-724-325-3577  
info.vacuum.ex@oerlikon.com  
Sales:  
Eastern & Central time zones  
Phone: +1-724-327-5700  
Fax: +1-724-333-1217  
Pacific, Mountain, Alaskan &  
Hawaiian time zones  
Phone: +1-408-436-2828  
Fax: +1-408-436-2849  
Service:  
Phone: +1-724-327-5700  
Fax: +1-724-325-3577

Latin America  
**Oerlikon**  
**Leybold Vacuum USA Inc.**  
**Brazilian Office**  
Av. Dória 360 cj. 12 Campo Belo  
04635-070 São Paulo SP BRAZIL  
Sales:  
Phone: +55 11-3554 3117  
Fax: +55 11-3554 3117  
nelson.batistucci@oerlikon.com

**Oerlikon**  
**Leybold Vacuum GmbH**  
Bonner Strasse 498  
D-50968 Cologne  
Phone: +49-(0)221-347 0  
Fax: +49-(0)221-347 1250  
info.vacuum@oerlikon.com

## Asia

P.R. China  
**Oerlikon**  
**Leybold Vacuum (Tianjin)**  
**International Trade Co. Ltd.**  
Beichen Economic  
Development Area (BEDA),  
No.8 Western Shuangchen Road  
Tianjin 300400  
China  
Sales and Service:  
Phone: +86-22-2697 0808  
Fax: +86-22-2697 4061  
Fax: +86-22-2697 2017  
info.vacuum.tj@oerlikon.com  
sales.vacuum.tj@oerlikon.com  
service.vacuum.tj@oerlikon.com

**Oerlikon**  
**Leybold Vacuum**  
**(Tianjin) Co. Ltd.**  
Beichen Economic  
Development Area (BEDA),  
No.8 Western Shuangchen Road  
Tianjin 300400  
China  
Sales and Service:  
Phone: +86-22-2697 0808  
Fax: +86-22-2697 4061  
info.vacuum.tj@oerlikon.com  
sales.vacuum.tj@oerlikon.com  
service.vacuum.tj@oerlikon.com

**Oerlikon**  
**Leybold Vacuum (Tianjin)**  
**International Trade Co. Ltd.**  
Shanghai Branch:  
No.33  
76 Fu Te Dong San Road  
Waigaoqiao Free Trade Zone  
Shanghai 200131  
China  
Sales and Service:  
Phone: +86-21-5064-4666  
Fax: +86-21-5064-4668  
info.vacuum.sh@oerlikon.com  
sales.vacuum.sh@oerlikon.com  
service.vacuum.sh@oerlikon.com

**Oerlikon**  
**Leybold Vacuum (Tianjin)**  
**International Trade Co. Ltd.**  
Guangzhou Office and  
Service Center  
1st F, Main Building  
Science City Plaza,  
No.111 Science Revenue,  
Guangzhou Science City  
(GZSC) 510663, Guangzhou,  
China  
Sales:  
Phone: +86-20-223 23 980  
Fax: +86-20-223 23 990  
info.vacuum.gz@oerlikon.com  
sales.vacuum.gz@oerlikon.com  
service.vacuum.gz@oerlikon.com

**Oerlikon**  
**Leybold Vacuum (Tianjin)**  
**International Trade Co. Ltd.**  
Beijing Branch:  
1-908, Beijing Landmark Towers  
8 North Dongsanhuang Road  
Beijing 100004  
China  
Sales:  
Phone: +86-10-6590-7622  
Fax: +86-10-6590-7607  
sales.vacuum.bj@oerlikon.com  
service.vacuum.bj@oerlikon.com

India  
**Oerlikon**  
**Leybold Vacuum India Pvt Ltd.**  
EL 22, J-Block  
MIDC Bhosari  
Pune 411026  
India  
Sales and Service:  
Phone: +91-20-3061 6000  
Fax: +91-20-2712 1571  
sales.vacuum.pu@oerlikon.com  
service.vacuum.pu@oerlikon.com

Japan  
**Oerlikon**  
**Leybold Vacuum**  
**Japan Co., Ltd.**  
Headquarter  
23-3, Shin-Yokohama  
3-chome  
Tobu A.K. Bldg. 4th Floor  
Kohoku-ku  
Yokohama-shi 222-0033  
Sales:  
Phone: +81-45-471-3330  
Fax: +81-45-471-3323  
info.vacuum.yh@oerlikon.com  
sales.vacuum.yh@oerlikon.com

**Oerlikon**  
**Leybold Vacuum**  
**Japan Co., Ltd.**  
Osaka Sales Office  
3F, Shin-Osaka Terasaki  
No.3 Bldg.  
1-5-28 Nishi-Miyahara  
Yodogawa-ku, Osaka-shi  
Osaka 532-0004  
Phone: +81-6-6399-6271  
Fax: +81-6-6399-6273  
info.vacuum.os@oerlikon.com  
sales.vacuum.os@oerlikon.com

**Oerlikon**  
**Leybold Vacuum**  
**Japan Co., Ltd.**  
Tsukuba Technical Service Center  
Kogyo Danchi  
21, Kasuminosato,  
Ami-machi, Inashiki-gun  
Ibaraki-ken, 300-0315  
Service:  
Phone: +81-298 89 2841  
Fax: +81-298 89 2838  
info.vacuum.iik@oerlikon.com  
sales.vacuum.iik@oerlikon.com

South Korea  
**Oerlikon**  
**Leybold Vacuum Korea Ltd.**  
3F, Jellzone 2 Tower  
Jeongja-dong 159-4  
Bundang-gu Sungnam-si  
Gyeonggi-do  
Bundang 463-384, Korea  
Sales:  
Phone: +82-31 785 1367  
Fax: +82-31 785 1359  
sales.vacuum.bd@oerlikon.com

Service:  
623-7, Upsung-Dong  
Cheonan-Si  
Chungcheongnam-Do  
Cheong 330-290  
Phone: +82-41 589 3035  
Fax: +82-41 588 0166  
service.vacuum.cn@oerlikon.com

Singapore  
**Oerlikon**  
**Leybold Vacuum**  
**Singapore Pte Ltd.**  
1 Science Park Road  
Singapore Science Park 2  
#02-12, Capricorn Building  
Singapore 117528  
Sales and Service:  
Phone: +65-6303 7000  
Fax: +65-6773 0039  
sales.vacuum.sg@oerlikon.com  
service.vacuum.sg@oerlikon.com

Taiwan  
**Oerlikon**  
**Leybold Vacuum Taiwan Ltd.**  
No 416-1, Sec. 3  
Chungshin Road., Chutung  
Hsinchu County 310  
Taiwan, R.O.C.  
Sales and Service:  
Phone: +886-3-500 1688  
Fax: +886-3-583 3999  
sales.vacuum.hc@oerlikon.com  
service.vacuum.hc@oerlikon.com

**oerlikon**  
**leybold vacuum**  
www.oerlikon.com/  
leyboldvacuum