



OPERATING INSTRUCTIONS

EN

Translation of the original instructions

TPR 270, TPR 271

Pirani Gauge

PFEIFFER  **VACUUM**

Table of contents

1	About this manual	3
	1.1 Validity	3
	1.2 Conventions	3
2	Safety	4
	2.1 Safety precautions	4
	2.2 Proper use	5
	2.3 Improper use	5
3	Product description	6
	3.1 Product identification	6
	3.2 Function	6
	3.3 Range of application	7
	3.4 Accuracy	7
	3.5 Gas type dependency	7
4	Transport and storage	7
5	Installation	8
	5.1 Vacuum connection	8
	5.2 Electrical connection	9
6	Operation	11
	6.1 Removal of components for their maintenance	11
7	Maintenance	11
	7.1 Adjusting the gauge	11
	7.2 Cleaning	12
8	Malfunctions	13
	8.1 Rectifying malfunctions	13
9	Service	14
10	Accessories	15
11	Technical data and dimensions	16
	11.1 General	16
	11.2 Technical data	16
	11.3 Dimensions	17
	11.4 Conversion	17
	11.5 Gas correction factor	19
	Declaration of conformity	20

1 About this manual

1.1 Validity

- TPR 270, TPR 271
 - Pfeiffer Vacuum product number PT R26 770, PT R26 775, PT R26 780, PT R26 781

This operating manual is for customers of Pfeiffer Vacuum. It describes the functioning of the designated product and provides the most important information for safe use of the unit. The description follows applicable EU guidelines. All information provided in this operating manual refers to the current state of the product's development. The documentation remains valid as long as the customer does not make any changes to the product.

Up-to-date operating instructions can also be downloaded from www.pfeiffer-vacuum.com.

1.2 Conventions

Safety instructions

The safety instructions in Pfeiffer Vacuum operating instructions are the result of risk evaluations and hazard analyses and are oriented on international certification standards as specified by UL, CSA, ANSI Z-535, SEMI S1, ISO 3864 and DIN 4844. In this document, the following hazard levels and information are considered:

DANGER
Imminent danger Indicates an imminent hazardous situation that will result in death or serious injury.
WARNING
Possibly imminent danger Indicates an imminent hazardous situation that can result in death or serious injury.
CAUTION
Possibly imminent danger Indicates an imminent hazardous situation that can result in minor or moderate injury.
NOTICE
Command or note Command to perform an action or information about properties, the disregarding of which may result in damage to the product.

Pictographs



Warning of a displayed source of danger in connection with operation of the unit or equipment



Command to perform an action or task associated with a source of danger, the disregarding of which may result in serious accidents



Important information about the product or this document

Instructions in the text

→ Work instruction: here you have to do something.

Abbreviations

TPR 270: Pirani gauge

TPR 271: Pirani gauge with increased corrosion protection

2 Safety

2.1 Safety precautions



Duty to inform

Each person involved in the installation or operation of the unit must read and observe the safety-related parts of these operating instructions.

→ The operator is obligated to make operating personnel aware of dangers originating from the unit or the entire system.

The gauges TPR 270, TPR 271 have been tested and accepted in compliance with EN 61010/VDE 0411 "Safety Equipment for Electrical Components".

- Observe the safety and accident prevention regulations.
- Check regularly that all safety precautions are being complied with.
- The unit has been accredited with protection class IP 40. Take necessary measures when installing into ambient conditions, which afford other protection classes.
- Consider possible reactions between the materials and the process media.
- Consider possible reactions of the process media due to the heat generated by the product.
- Do not modify or alter the unit yourself.
- Note the shipping instructions, when returning the unit.
- Inform yourself about a possible contamination before starting work.
- Adhere to the relevant regulations and take the necessary precautions, when handling contaminated parts.
- Communicate the safety instructions to other users.

2.2 Proper use

- Only use the TPR 270, TPR 271 gauges for measuring total pressures in the $1 \cdot 10^{-4}$... 1000 hPa range.
- Only use the gauge **TPR 270** for air, inert gases and gas mixtures outside their explosion limits.

Because of its material, the TPR 271 gauge can also be used for corrosive gases and gas mixtures outside their explosion limits, if the materials with media contact specified in the technical data are not attacked by these gases and gas mixtures.

2.3 Improper use

Improper use will cause all claims for liability and warranties to be forfeited. Improper use is defined as usage for purposes deviating from those mentioned above, especially:

- operation in potentially explosive areas
- pumping of explosive media
- connection to pumps or units which are not suitable for this purpose according to their operating instructions
- connection to units which have exposed voltage-carrying parts
- operation of the devices in areas with ionizing radiation

3 Product description

The gauges TPR 270, TPR 271 are equipped with a temperature-compensated Pirani sensor and enables total pressure measurements in the range of $1 \cdot 10^{-4} \dots 1000 \text{ hPa}$. Are the gauges being operated with a controller, a calibration factor can be applied for correction of the non-linear characteristics in the pressure range $< 0.5 \text{ hPa}$ for different gases.

3.1 Product identification

To correctly identify the product when communicating with Pfeiffer Vacuum, always have the information from the rating plate available.

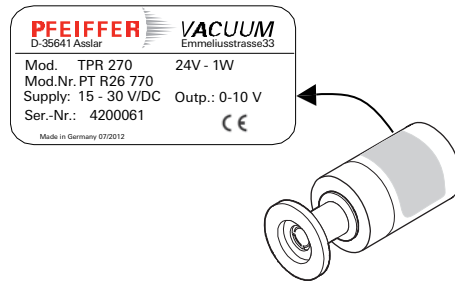

Fig. 1: Product identification on the rating plate (example)

Scope of delivery

The following positions are included in the delivery consignment:

- TPR 270, TPR 271
- Protective cover
- Operating instructions

3.2 Function

The sensors are based on the thermal conductivity of gases for vacuum pressure measurements (Pirani principle). A thin tungsten or platinum/rhodium wire is heated up cyclically to a certain temperature. The time required for heating is a measure for the pressure.

The gauge can be operated with an ActiveLine controller or with a customer related control device.

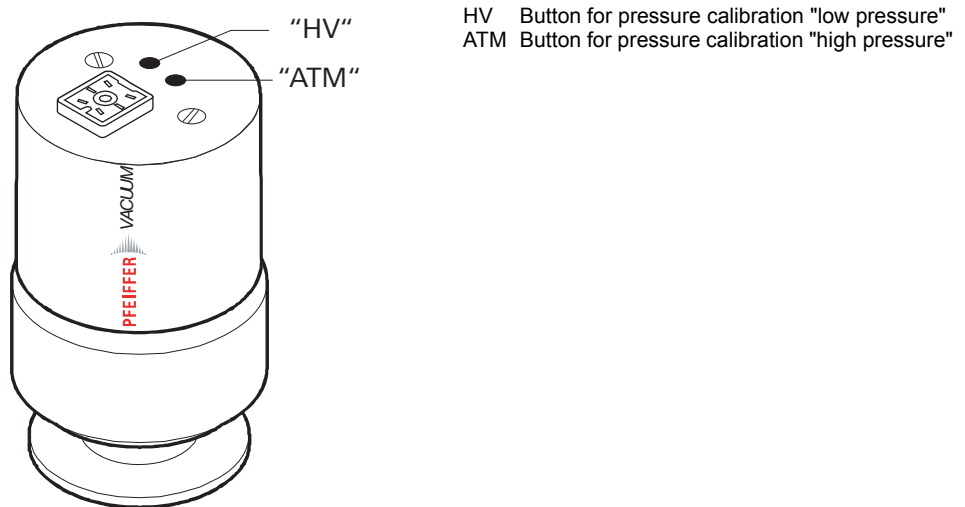

Fig. 2: TPR 270, TPR 271

3.3 Range of application

The gauges TPR 270, TPR 271 must be installed and operated in the following ambient conditions:

Installation location	weather protected (indoor)
Protection class	IP 40
Installation altitude	max. 2000 m
Ambient temperature	+5°C to +40°C
Relative humidity	5 ... 85 %, non-condensing
Atmospheric pressure	860 hPa - 1060 hPa

3.4 Accuracy

The gauge is factory-calibrated for air. Adjustment may be necessary because of the use in different climatic conditions, extreme temperatures, contamination or ageing. Measurement accuracy is reduced in the upper and lower range.

3.5 Gas type dependency

The measuring signal depends on the type of gas being measured. The relationship between measuring signal and pressure is accurate for N₂, O₂, dry air and CO . For other gases consult the list of correction factors in the operating instructions (*see p. 19, chap. 11.5*). When the gauge is operated with an ActiveLine controller, a calibration factor can be set to achieve the correct reading (please refer to the operating instructions of the appropriate controller).

4 Transport and storage

Units without external protection must not come into contact with electrostatically chargeable materials and must not be moved within electrical or magnetic fields.

- In rooms with moist or aggressive atmospheres, the unit must be airproof shrink-wrapped in a plastic bag together with a bag of desiccant.
- Keep the original protective covers.

5 Installation

5.1 Vacuum connection



NOTICE

Vacuum component

Dirt and damage impair the function of the vacuum component.

- When handling vacuum components, ensure that they are kept clean and are protected against damage.
- Ensure that the connection flange is clean, dry and free of grease.

CAUTION

Excess pressure in the vacuum system 1500 to 4000 hPa

Damage to health through emission of process media, because elastomer washers cannot withstand the pressure.

- Use sealing rings with an outer centering ring.

Mounting orientation

The installation position can be freely selected. The preferred position is a horizontal to vertical position so that condensate and particles do not penetrate the measurement chamber.

To facilitate adjustment after the gauge has been installed, a free space of about 40 mm in axial direction should be assured in front of the "ATM" and "HV" push buttons.

Connecting the gauge



CAUTION

Missing protective grounding!

The gauge must be electrically connected to the grounded vacuum chamber.

- For gauges with a KF flange, use a conductive metallic clamping ring.
- Carry out the flange connection according to the requirements of DIN EN 61010.



CAUTION

Excess pressure in the vacuum system > 1000 hPa

Danger of injuries by inadvertent opening of elements under stress due to parts flying around.

- Only use stressed elements, which can be opened and closed with appropriate tools (e.g. strap retainer-tension ring).

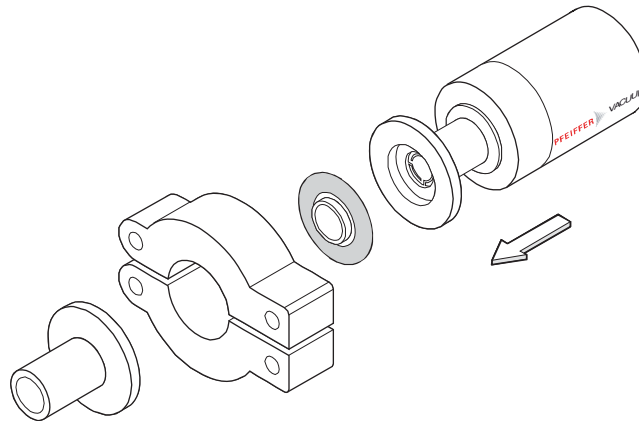

Fig. 3: Make the flange connection

- Remove the protective cover, which is required during maintenance work.
- Make the flange connection.

5.2 Electrical connection



NOTICE

Damage to the product

Only connect cables when de-energized.

- Never establish a connection using a live cable.

Controllers

The smallest presentable reading is $5 \cdot 10^{-4}$ hPa at operation with Pfeiffer Vacuum controllers.

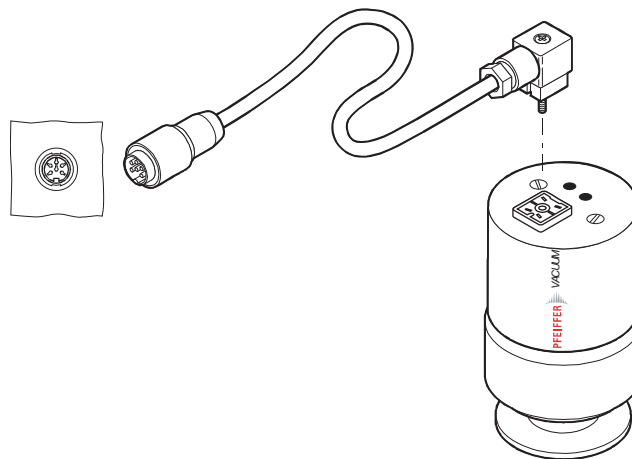

Fig. 4: Connect TPR 270, TPR 271

- Connect the gauge to the control unit using the connection cable.
- Secure the plug at the gauge with the existing screw.

Other use

The gauge can also be operated with other control devices. In this case a sensor cable (shielded) must be made by the user. For cable lengths up to 10 m (with 0.25 mm^2 conductor cross section), the measuring signal can be read directly between analog output (pin 2) and ground (pin 5). For longer sensor cable lengths, we recommend a differential measurement between analog output and analog ground (pin 3). As a result of the voltage drop along the supply cable grounding lead, the common mode signal is approx. 0.5 V at the max. permissible cable length.

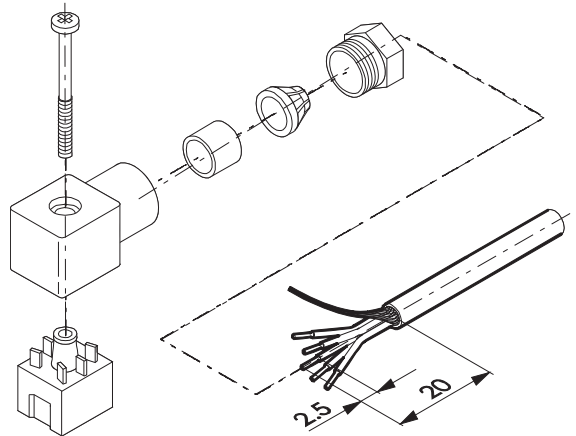
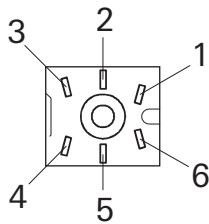

Fig. 5: Assemble connection cable

Pin assignment



NOTICE	
Damaging the gauge	
Incorrect connection, incorrect polarity or inadmissible supply voltages can damage the transmitter.	
→ Ground (pin 5) and shielding (pin 6) must always be grounded at the controller.	



Pin	Pin assignment
1	Identification (3.0 kΩ to GND)
2	Analog output 0 ... 10V, (measuring range TPR 270: 1.5 ... 8.5 V; TPR 271: 2.2 ... 8.5 V)
3	Analog ground
4	Supply (V DC), 15 ... 30V
5	Ground (GND)
6	Shielding

- Solder in cable according pin assignment.
- Assemble cable socket.
- Connect the other end of the gauge cable according to the pin assignment of the appropriate control device.
- Connect the gauge to the control unit using the connection cable.
- Switch on the control unit.

6 Operation

After switching on the power supply, the connected gauge is ready for operation. It is advisable to wait for a stabilization period of 5-10 minutes before measurement. Operate the gauge during the measurement continuously independent of the applied pressure.

6.1 Removal of components for their maintenance



WARNING

Contamination of gauge parts possible due to the media measured!

Poisoning hazard through contact with harmful substances.

- In the case of contamination, carry out appropriate safety precautions in order to prevent danger to health through dangerous substances.
- Decontaminate affected parts before carrying out maintenance work.



NOTICE

Vacuum component

Dirt and damage impair the function of the vacuum component.

- When handling vacuum components, ensure that they are kept clean and are protected against damage.
- Ensure that the connection flange is clean, dry and free of grease.



- Switch off the power supply on the control unit/power supply or disconnect the equipment from the mains supply.
- Loosen any connection cables.
- Detach the gauge from the vacuum apparatus.
- Close the flange opening by using the original protective cover.

7 Maintenance

The unit requires no maintenance. A damp cloth can be used to wipe away any external dirt.

7.1 Adjusting the gauge

The gauge is factory calibrated at 24 V supply voltage. Through the use in different climatic conditions, through extreme temperatures, deviating supply voltage, contamination or ageing a shifting of the characteristic curve can occur and readjustment might be necessary. The adjustment does not affect the pressure range between 10^{-2} and 10 hPa. Before adjustment, the gauge should be operated at the relevant pressure for approx. 5–10 minutes (warm-up time).

For correct zero point adjustment, the pressure in the vacuum chamber must be $p \leq 1 \cdot 10^{-5}$ hPa.

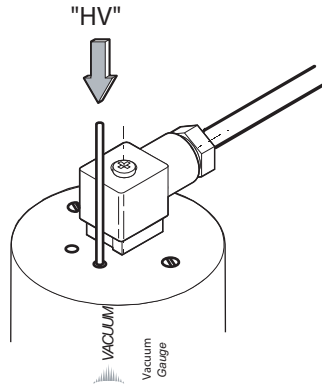

Fig. 6: Adjusting the gauge measuring range

- Evacuate the vacuum chamber to the pressure $p \leq 1 \cdot 10^{-5}$ hPa.
- Remove the rubber plugs from the "HV" / "ATM" buttons access holes.
- Push the "HV" button briefly with a small pin (screw driver, Allen key or the like).

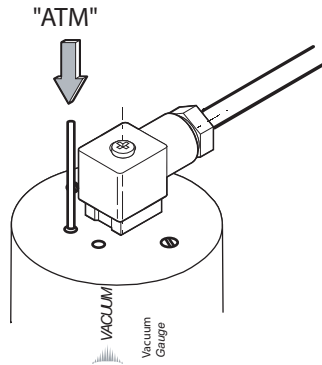

Fig. 7: Adjusting the gauge measuring range

- Vent vacuum chamber to atmospheric pressure with air or N₂; afterwards wait about 10 minutes.
- Push the "ATM" button briefly with a small pin (screw driver, Allen key or the like).
- Reinsert "HV"/"ATM" rubber plugs.

7.2 Cleaning



WARNING

Explosion hazard

The use of volatile or combustible cleaning agents in vacuum systems can lead to explosive vapour-air mixtures.

- After cleaning ventilate and let dry completely.



CAUTION

Use suitable cleaning agents!

Cleaning agents can be detrimental to health and the environment!

- Adhere to the relevant regulations when using cleaning agents.
- Never use propanone (e.g. acetone) or halogenated hydrocarbons for cleaning!



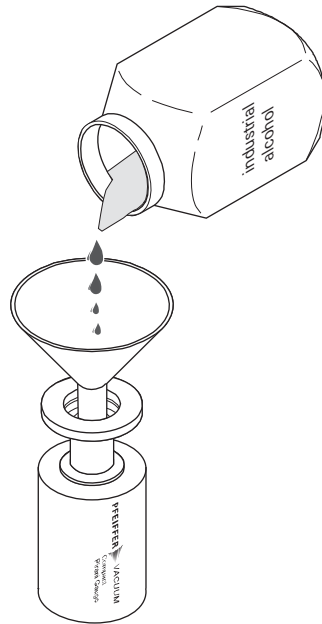

Fig. 8: Clean gauge

- Detach the gauge from the vacuum apparatus.
- Fill carefully with industrial alcohol; allow to soak for 5 minutes.
- Pour out the alcohol and dispose of according to the local regulations.
- Allow the measurement chamber to dry sufficiently (at least 10 minutes).
- Connect the gauge to the vacuum chamber.
- Evacuate the gauge.
- Bring gauge up to operating temperature (≥ 5 minutes).
- Adjust the gauge.

8 Malfunctions

8.1 Rectifying malfunctions

Problem	Possible causes	Remedy
Measuring signal continually < 0.5 V; Display controller: "ErLo" or "Sensor Error"	<ul style="list-style-type: none"> • No supply voltage • Gauge maladjusted • Gauge defective 	<ul style="list-style-type: none"> ⇒ Check connecting cable, power supply or controller ⇒ Adjust the gauge ⇒ Replace the gauge
Reading is too high at low pressures	<ul style="list-style-type: none"> • Strong outgassing of the sensor • Sensor contaminated 	<ul style="list-style-type: none"> ⇒ Clean the gauge ⇒ Adjust the gauge ⇒ Replace the gauge

9 Service

Malfunctions of the transmitter, caused by contamination or wear, as well as wear parts (e.g. heating filament) are not covered by warranty.

- A repair is uneconomical for the unit and therefore not intended in case of damage.
- Send unit and have it replaced with a new unit.

Sending of units (under warranty)

For a quick and smooth handling of the service process, Pfeiffer Vacuum recommends the following steps:

- Download the forms "Service Request" and Declaration of Contamination.¹⁾
- Fill out the "Service Request" form and send it by fax or e-mail to your local Pfeiffer Vacuum service contact.
- Include the confirmation on the "Service Request" from Pfeiffer Vacuum with your shipment.
- Fill out the Declaration of Contamination and include it in the shipment. This document is mandatory to protect our service engineers.
 - Fill out and send one declaration for each device.
- If possible, send unit in the original packaging.

In the absence or incompleteness of the "Declaration of Contamination" and/or the use of unsuitable transport packaging, Pfeiffer Vacuum reserves the right to make a decontamination and/or to send the product back at the shipper's expense.

Service orders

All service orders are carried out exclusively according to our repair conditions for vacuum units and components. Detailed information, addresses and forms at:

<http://www.pfeiffer-vacuum.com/service/repair-services/container.action>.

¹⁾ Forms under www.pfeiffer-vacuum.com

10 Accessories

Designation	TPR 270
Mating connector	B 4707 283 MA
Sensor cable, 3 m	PT 448 250 -T
Sensor cable, 6 m	PT 448 251 -T
Sensor cable, 10 m	PT 448 252 -T

11 Technical data and dimensions

11.1 General

Conversion table: pressure units

	mbar	bar	Pa	hPa	kPa	Torr mm Hg
mbar	1	$1 \cdot 10^{-3}$	100	1	0.1	0.75
bar	1000	1	$1 \cdot 10^5$	1000	100	750
Pa	0.01	$1 \cdot 10^{-5}$	1	0.01	$1 \cdot 10^{-3}$	$7.5 \cdot 10^{-3}$
hPa	1	$1 \cdot 10^{-3}$	100	1	0.1	0.75
kPa	10	0.01	1000	10	1	7.5
Torr mm Hg	1.33	$1.33 \cdot 10^{-3}$	133.32	1.33	0.133	1

$1 \text{ Pa} = 1 \text{ N/m}^2$

11.2 Technical data

Parameter	TPR 270	TPR 270	TPR 270	TPR 271
Connection for gauge	6-pole female cable connector, screw-fastened	6-pole female cable connector, screw-fastened	6-pole female cable connector, screw-fastened	6-pole female cable connector, screw-fastened
Nominal diameter	DN 16 ISO-KF	DN 16 CF-F	1/8" NPT	DN 16 ISO-KF
Protection category	IP40	IP40	IP40	IP40
Output signal: Pressure range	1.5 - 8.5 V	1.5 - 8.5 V	1.5-8.5 V	2.2-8.5 V
Bakeout temperature	80 °C	80 °C	80 °C	80 °C
Power consumption max.	At 24 V < 1 W	At 24 V < 1 W	At 24 V < 1 W	At 24 V < 1 W
Seal	Metal	Metal	Metal	Metal
Pressure max.	4000 hPa	4000 hPa	4000 hPa	4000 hPa
Feedthrough	Glass	Glass	Glass	Glass
Accuracy: % of measurement	$2 \cdot 10^{-3}$hPa: <Faktor 2, $2 \cdot 10^{-3}$ - 20 hPa: $\pm 10\%$, 20 - 1000 hPa: $\pm 30\%$	$2 \cdot 10^{-3}$hPa: <Faktor 2, $2 \cdot 10^{-3}$ - 20 hPa: $\pm 10\%$, 20 - 1000 hPa: $\pm 30\%$	$2 \cdot 10^{-3}$hPa: <Faktor 2, $2 \cdot 10^{-3}$ - 20 hPa: $\pm 10\%$, 20 - 1000 hPa: $\pm 30\%$	$1 \cdot 10^{-2}$hPa: <Faktor 2, $1 \cdot 10^{-2}$ - 10 hPa: $\pm 10\%$, 10 - 1000 hPa: $\pm 30\%$
Weight	105 g	135 g	95 g	105 g
Filament	Tungsten	Tungsten	Tungsten	Platinum/rhodium
Materials in contact with media	Tungsten, stainless steel 1.4307, nickel	Tungsten, stainless steel 1.4307, nickel	Tungsten, stainless steel 1.4307, nickel	Platinum/rhodium, stainless steel 1.4307, nickel
Measurement range max.	1000 hPa	1000 hPa	1000 hPa	1000 hPa
Measurement range min.	$1 \cdot 10^{-4}$ hPa	$1 \cdot 10^{-4}$ hPa	$1 \cdot 10^{-4}$ hPa	$5 \cdot 10^{-4}$ hPa
Sensor cable length	≤ 150 (5 x 0,25 mm ²); ≤ 200 (5 x 0,34 mm ²) m	≤ 150 (5 x 0,25 mm ²); ≤ 200 (5 x 0,34 mm ²) m	≤ 150 (5 x 0,25 mm ²); ≤ 200 (5 x 0,34 mm ²) m	≤ 150 (5 x 0,25 mm ²); ≤ 200 (5 x 0,34 mm ²) m
Method of measurement	Pulse-Pirani	Pulse-Pirani	Pulse-Pirani	Pulse-Pirani
Temperature: Operating	+5-+60 °C	+5-+60 °C	+5-+60 °C	+5-+60 °C
Temperature: Storage	-40-+70 °C	-40-+70 °C	-40-+70 °C	-40-+70 °C
Supply: Voltage	15-30 V DC	15-30 V DC	15-30 V DC	15-30 V DC
Repeatability: % of measurement	$2 \cdot 10^{-3}$ - 20 hPa $\pm 2\%$	$2 \cdot 10^{-3}$ - 20 hPa $\pm 2\%$	$2 \cdot 10^{-3}$ - 20 hPa $\pm 2\%$	$1 \cdot 10^{-2}$ - 10 hPa $\pm 2\%$

11.3 Dimensions

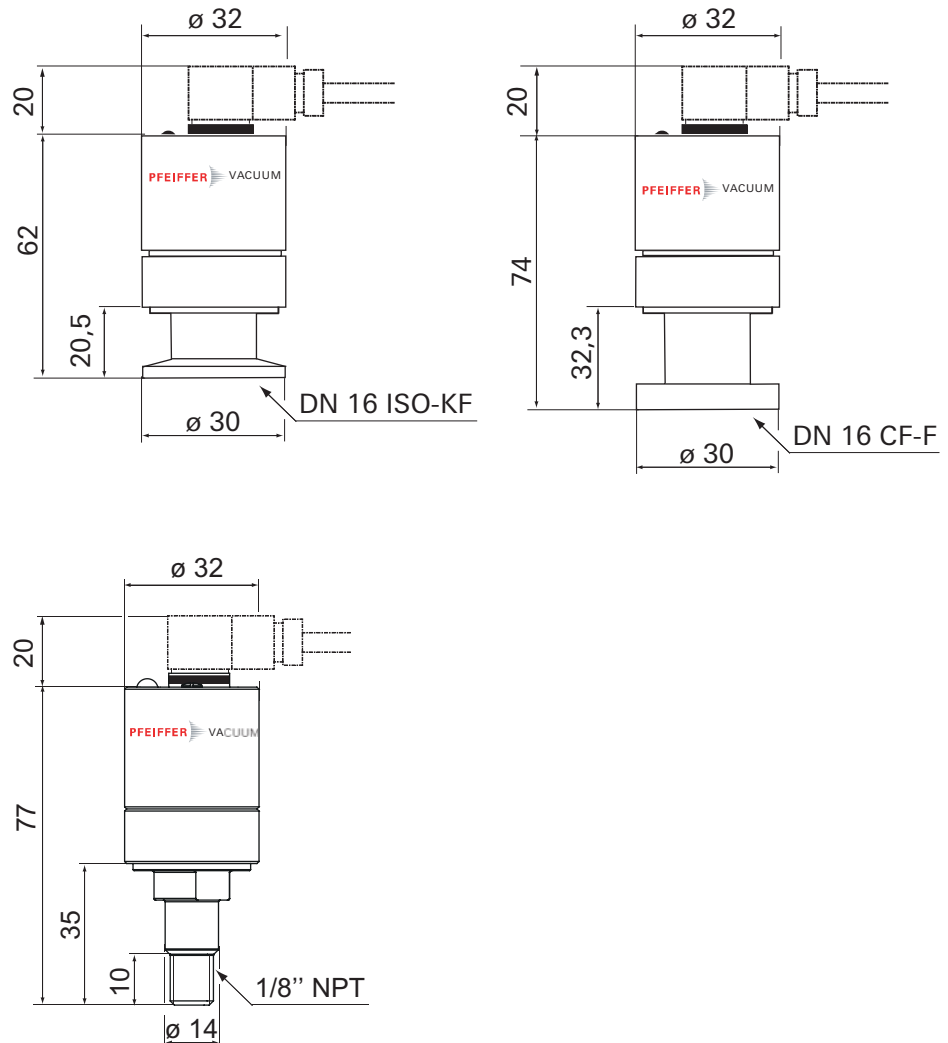

11.4 Conversion

Conversion formula

$$p=10^{(U-c)} \Leftrightarrow U=c+\log_{10}p$$

- p: Pressure
- U: Measuring signal
- c: Constant

U	p	c
[V]	[mbar, hPa]	5.5
[V]	[Torr]	5.625
[V]	[mTorr]	2.625
[V]	[micron]	2.625
[V]	[Pa]	3.5
[V]	[kPa]	6.5

Table 1: valid in the range: $1 \cdot 10^{-4}$ hPa < p < 1000 hPa

TPR 270

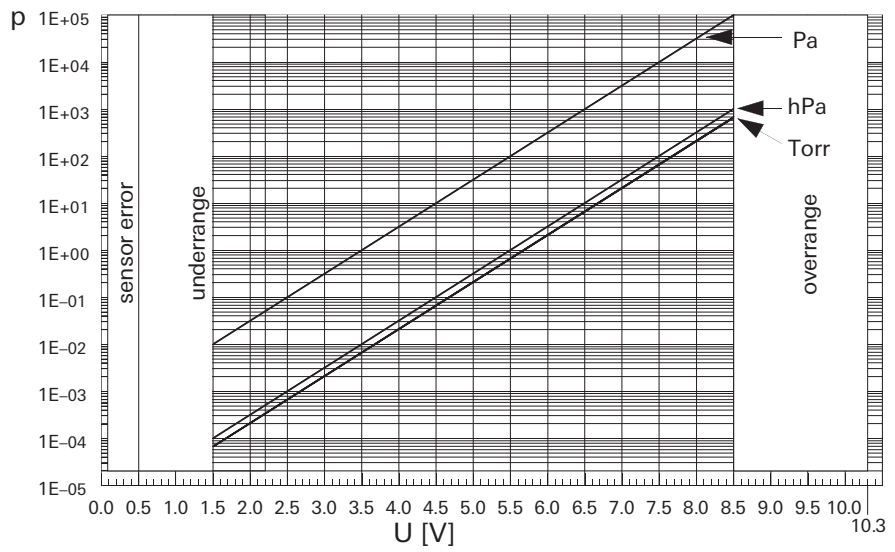

TPR 271

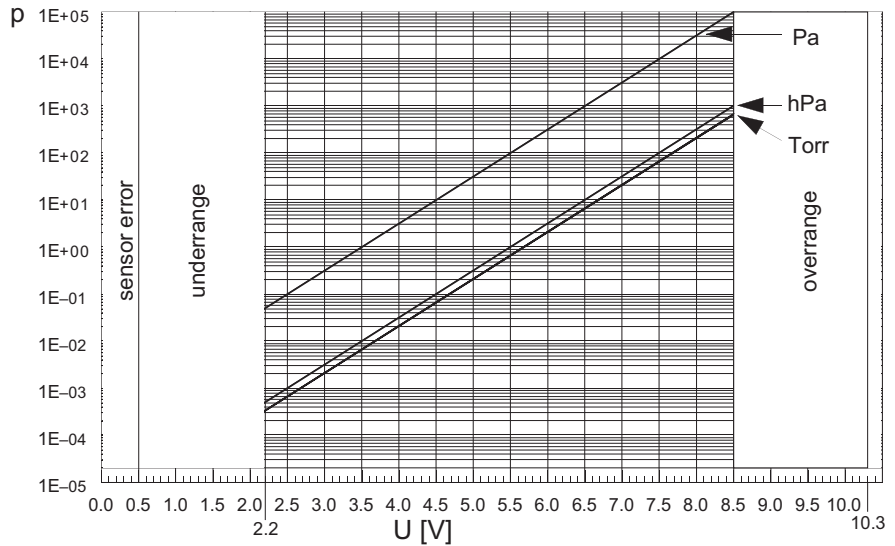

Conversion table

Measuring signal U [V]	Pressure p [hPa]
< 0.5	Sensor error
0.5 ... 1.5	Underrange
1.5	$1 \cdot 10^{-4}$
2.5	$1 \cdot 10^{-3}$
3.5	$1 \cdot 10^{-2}$
4.5	0.1
5.5	1.0
6.5	10
7.5	100
8.5	1000
8.5 ... 10.3	Overrange

11.5 Gas correction factor

In case of different gases, accurate determination is only possible with a partial pressure measurement instrument, e. g. a quadrupole mass spectrometer.

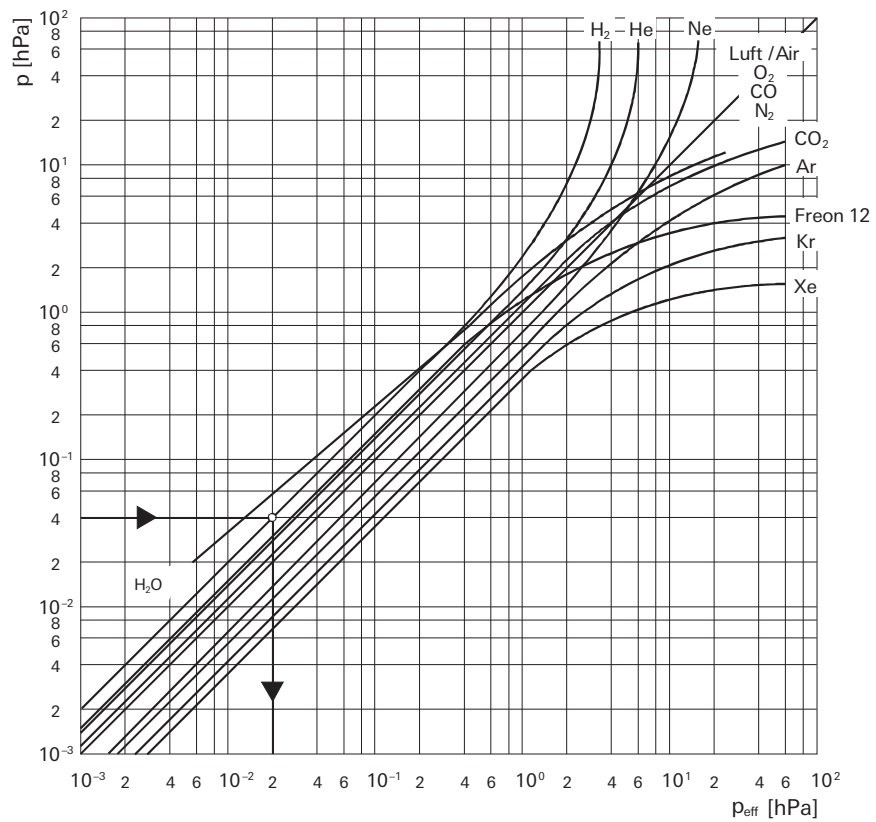

Fig. 9: Measurement curve TPR 270, TPR 271 (Pirani)

He	1.00	Correction factor K for the linear range: $p_{\text{eff}} = K \times \text{indicated pressure}$
Ne	1.40	
Ar	1.60	
Kr	2.40	
N ₂	1.00	
Luft	1.00	
H ₂	0.57	
CO	1.0	
CO ₂	0.89	

Table 2: Correction factor for the pressure range < 1 hPa



Declaration of conformity

We hereby declare that the product cited below satisfies all relevant provisions according to the following **EC directives**:

- **Electromagnetic Compatibility 2014/30/EU**
- **Restriction of the use of certain Hazardous Substances 2011/65/EU**

ActiveLine
TPR 270, TPR 271

Harmonised standards and national standards and specifications which have been applied:

EN 61326-1: 2013 Group 1 / Class B
EN 50581: 2012

Signature:

Pfeiffer Vacuum GmbH
Berliner Straße 43
35614 Asslar
Germany

(Dr. Ulrich von Hülsen)
Managing Director

2016-11-07

VACUUM SOLUTIONS FROM A SINGLE SOURCE

Pfeiffer Vacuum stands for innovative and custom vacuum solutions worldwide, technological perfection, competent advice and reliable service.

COMPLETE RANGE OF PRODUCTS

From a single component to complex systems:

We are the only supplier of vacuum technology that provides a complete product portfolio.

COMPETENCE IN THEORY AND PRACTICE

Benefit from our know-how and our portfolio of training opportunities!

We support you with your plant layout and provide first-class on-site service worldwide.

**Are you looking for a
perfect vacuum solution?
Please contact us:**

Pfeiffer Vacuum GmbH
Headquarters • Germany
T +49 6441 802-0
info@pfeiffer-vacuum.de

www.pfeiffer-vacuum.com

PFEIFFER  **VACUUM**