



# nEXT85 SERVICE TOOL KIT

Publication Number: B8G2-00-840

Issue: A

Original Instructions

## **Copyright notice**

©Edwards Limited 2017. All rights reserved.

## **Trademark credits**

Edwards and the Edwards logo are trademarks of Edwards Limited.

# Contents

Copyright notice.....	2
Trademark credits.....	2
List of Figures.....	4
List of Tables.....	5
<b>Safety and compliance</b> .....	<b>6</b>
Definition of Warnings and Cautions.....	6
Safety symbols.....	6
<b>General description</b> .....	<b>7</b>
Overview.....	7
<b>Pre-service</b> .....	<b>8</b>
Unpack and inspect.....	8
Additional tools and items required.....	9
Service kit.....	9
Preload check.....	9
Bearing preload familiarisation.....	10
<b>Service</b> .....	<b>11</b>
Disassembly.....	11
Oil cartridge removal.....	11
Oil feed nut removal.....	12
Bearing retaining nut removal.....	13
Bearing module removal.....	14
Reassembly.....	14
Bearing module insertion.....	14
Bearing retaining nut assembly.....	15
Oil feed nut assembly.....	16
Oil cartridge assembly.....	16
Bearing preload check.....	17
Service counter reset.....	18
Reset the service interval using a Turbo Instrument Controller (TIC).....	19
Reset the service interval using a PC serial command.....	20
Reset the service interval using a nST PC program.....	20
Reset the service interval using the turbo drive standby speed control buttons.....	21
Pump checks.....	22
Clearance check.....	22
Vacuum leak check.....	22
Operational checks.....	22

## List of Figures

Figure 1: Pin spanner adaptor.....	8
Figure 2: Bearing module extractor tool.....	8
Figure 3: Bearing preload measurement and setting tool.....	9
Figure 4: Locating the preload tool (NW40 variant shown).....	10
Figure 5: Oil cartridge removal.....	12
Figure 6: Oil feed nut removal.....	13
Figure 7: Bearing retaining nut removal.....	13
Figure 8: Bearing module removal.....	14
Figure 9: Bearing module insertion.....	15
Figure 10: Bearing retaining nut assembly.....	15
Figure 11: Oil feed nut assembly.....	16
Figure 12: Oil cartridge assembly.....	17
Figure 13: Preload tool (pass / fail indication).....	18
Figure 14: Motor controller status information.....	21
Figure 15: Clearance check.....	22

## List of Tables

Table 1: Checklist of components for the bearing exchange tool kit B8G200845.....	8
Table 2: Front panel symbols and their functions.....	19

# Safety and compliance

## Definition of Warnings and Cautions

Important safety information is highlighted as WARNING and CAUTION instructions; these instructions must be obeyed.

The use of WARNINGS and CAUTIONS is defined below.



### **WARNING:**

Warnings are given where failure to observe the instruction could result in injury or death to people. The actual symbol shown varies according to the hazard.



### **CAUTION:**

Cautions are given where failure to observe the instruction could result in damage to the equipment, associated equipment or process.

## Safety symbols

The safety symbols on the products denote areas where care and attention is required.

The following safety symbols may be used on the nEXT85 or throughout the product documentation.

	<p style="text-align: center;">Warning/Caution</p> <p style="text-align: center;">An appropriate safety instruction should be followed or caution to a potential hazard exists.</p>
	<p style="text-align: center;">Warning - Dangerous Voltage</p> <p style="text-align: center;">Indicates hazards arising from dangerous voltages.</p>

# General description

## Overview

This manual provides step by step instructions for the removal and insertion of the bearing module on the nEXT85 pump.

Remove the bearing module as specified in this manual.

# Pre-service

## Unpack and inspect

Remove all packaging and check that all items listed in [Table 1](#) on page 8 have been received. If any of these items are missing, notify the supplier in writing within three days.

**Table 1** Checklist of components for the bearing exchange tool kit B8G200845

Quantity	Description	Reference	Check
1	Pin spanner adaptor	<a href="#">Figure 1</a> on page 8	<input type="checkbox"/>
1	Bearing module extractor tool	<a href="#">Figure 2</a> on page 8	<input type="checkbox"/>
1	Bearing preload measurement and setting tool	<a href="#">Figure 3</a> on page 9	<input type="checkbox"/>

**Figure 1** Pin spanner adaptor

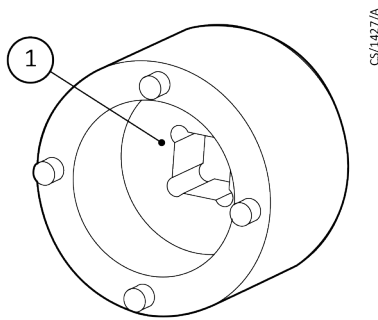

1. 1/4" square drive

**Figure 2** Bearing module extractor tool

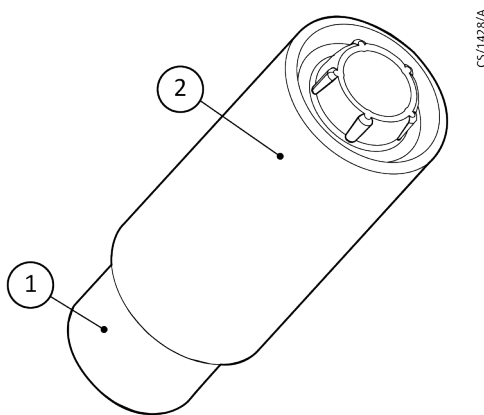

1. Bearing anti-rotating tube
2. Bearing extractor sleeve

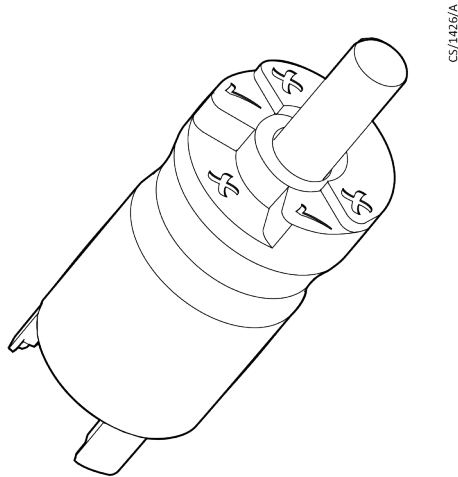

**Figure 3** Bearing preload measurement and setting tool

## Additional tools and items required

Additional tools are required to perform a bearing module and oil cartridge replacement.

These items are not part of the bearing exchange tool kit B8G200845 and will need to be acquired separately.

- T15 Torx screwdriver
- Torque driver (torque range required 2 to 6 Nm)
- ¼" square drive
- 2.5 mm AF hex key or T-bar
- T10 Torx drive bit
- 4 mm hex bit
- Lint-free cloth
- Latex gloves (recommended)

## Service kit

Before commencing with the bearing module service, confirm that you have purchased the correct bearing and oil cartridge service kit B8G200811 or oil cartridge service kit B8G200828.

## Preload check



### **WARNING:**

**Allow the pump rotor to stop and then disconnect the motor controller before you remove the pump from your vacuum system for maintenance or fault finding procedures.**

*Service* on page 11 describes how to perform an oil cartridge and bearing module replacement.

Part of this process involves checking the bearing preload condition after the service has been completed. Preload is the process wherein a permanent thrust load is applied to the main bearing. Thrust is applied by the misalignment between the inner static and the outer rotating passive magnetic bearing located at the inlet of the pump.

In order to become familiar with how to recognise bearing preload after a service, it is recommended that the instructions in [Bearing preload familiarisation](#) on page 10 are followed.

## Bearing preload familiarisation



### CAUTION:

Ensure all tools are clean and free of dirt and grease to avoid contamination of the rotor.

This procedure should be performed with the pump placed in the vertical position.

1. Place the preload tool onto the inlet of the turbomolecular pump. The force probe must be located into the centre of the pump inlet with the adjuster legs engaged onto the magnetic bearing adjuster nut [Figure 4](#) on page 10. Supporting the preload tool body in position while performing the preload check is recommended.
2. Apply pressure by pushing the test plunger until a change in preload can be detected. Releasing the test plunger will return the preload back to its original position. Pressing and releasing the test plunger slowly while performing this check is recommended.



### Note:

*Detection of the bearing preload can be recognised by a distinct sound. This may be accompanied by a sensory feel through the tool and pump body. If a change in preload cannot be detected, it may be possible to carry on with the service but with caution.*



### CAUTION:

If the pump has suffered any damage (i.e. the rotor does not spin freely or quietly), it is recommended that the service is not carried out and that the local service centre is contacted for advice.

**Figure 4** Locating the preload tool (NW40 variant shown)

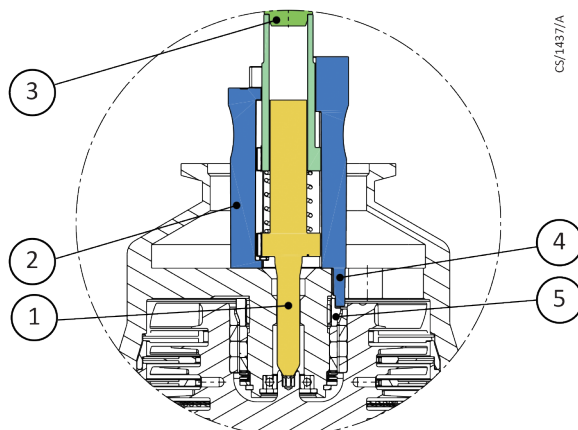

- |                             |                                  |
|-----------------------------|----------------------------------|
| 1. Preload tool force probe | 4. Preload tool adjuster legs    |
| 2. Preload tool body        | 5. Magnetic bearing adjuster nut |
| 3. Preload test plunger     |                                  |

## Service

It is highly recommended that the bearing module service should be performed in a clean environment, free from contamination (metallic debris, dust, human skin and hair).

To ensure this:

- Clean the immediate working area and wipe clean the base of the pump with a lint-free cloth before starting work.
- Ensure all hand tools are scrupulously clean and free from damage or burrs (demagnetising hand tools is recommended).
- Always wear gloves when handling the bearing unit and surrounding parts.
- A laminar flow bench or clean room is helpful, but not essential.



### CAUTION:

**It is recommended that the pump is in a stable horizontal position when performing this service. Ensure the vacuum ports are protected to prevent any damage.**



### Note:

*For the purpose of removal and reassembly, all screws and components with screw fixings use right-handed threads.*

## Disassembly

### Oil cartridge removal

Refer to [Figure 5](#) on page 12.

1. Unscrew and remove the 4 x M4 button head screws holding the oil cartridge.
2. Remove the oil cartridge from the pump body.



### Note:

*If replacing the oil cartridge only, go straight to [Oil cartridge assembly](#) on page 16 after following this instruction.*

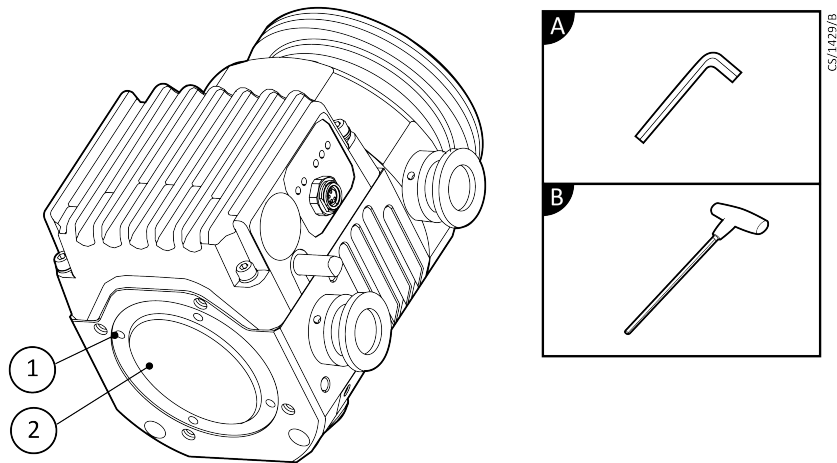
**Figure 5** Oil cartridge removal

1. 4 x M4 button head screws

2. Oil cartridge base cap

Tools (A or B)

A. 2.5 mm AF hex key

B. T-bar

### Oil feed nut removal

Refer to [Figure 6](#) on page 13.

1. Engage the T10 Torx with driver into the end of the oil feed nut.
2. Engage the T15 Torx screwdriver through the end of the shaft via the pump inlet.
3. While keeping the T15 Torx screwdriver stationary, undo and remove the oil feed nut.
4. Place the oil feed nut in a dry clean place.

**Figure 6** Oil feed nut removal

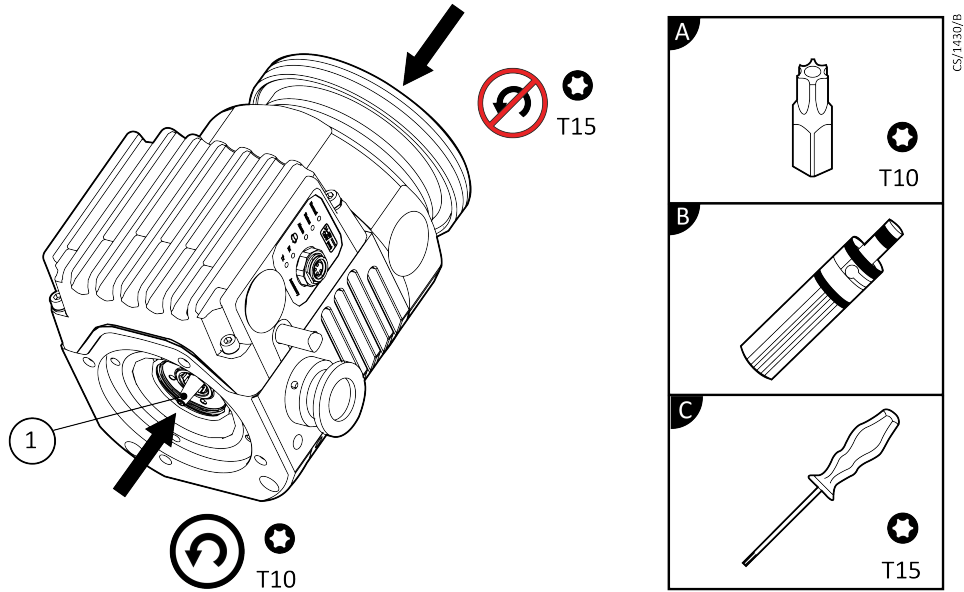

1. Oil feed nut

**Tools**

- A. T10 Torx drive bit
- B. Torque driver
- C. T15 Torx screwdriver

**Bearing retaining nut removal**

Refer to [Figure 7](#) on page 13.

1. Using the combination of tools, engage the pins of the pin spanner adaptor into the pump bearing retaining nut.
2. While holding the pump body, undo and remove the bearing retaining nut.
3. Place the retaining nut in a dry clean place.

**Figure 7** Bearing retaining nut removal

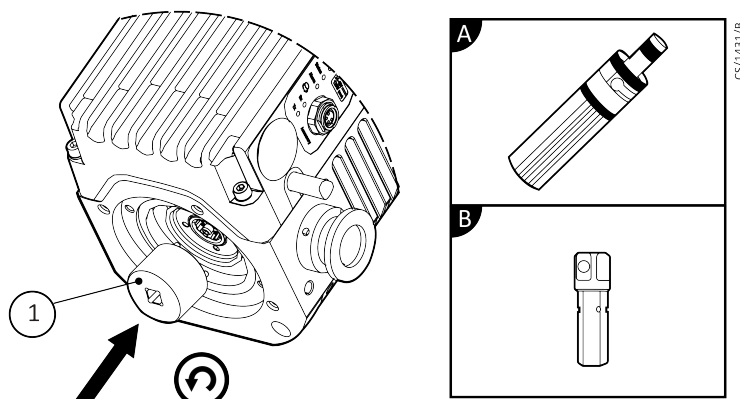

1. Pin spanner adaptor

## Tools

- A. Torque driver
- B. ¼" square drive

## Bearing module removal

Refer to [Figure 8](#) on page 14.

1. Screw the bearing extractor sleeve onto the bearing module.



### Note:

*The bearing anti-rotating tube may be used to prevent the bearing from rotating while the extractor sleeve is fitted. Slide the tube inside the sleeve and apply a small force onto the bearing while rotating the extractor sleeve.*

2. Firmly hold the pump body and remove the bearing module by pulling the extractor sleeve squarely away from the pump body.
3. Once extracted, remove the bearing module from the bearing extractor sleeve.
4. As a precaution, clean any contamination that might be present from the extractor thread using a dry lint-free cloth.

**Figure 8** Bearing module removal

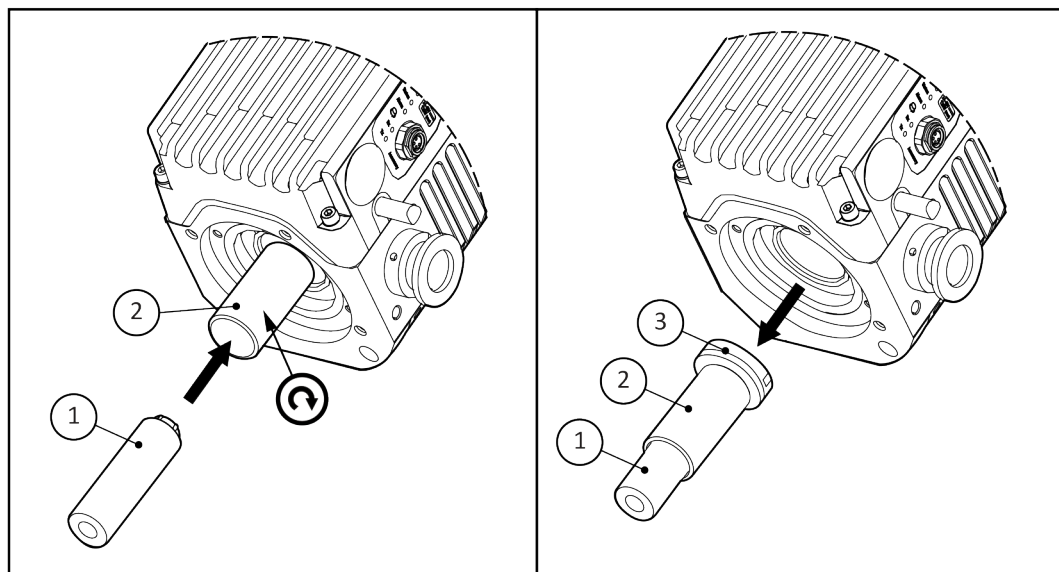

CS/1432/8

1. Bearing anti-rotating tube
2. Bearing extractor sleeve

3. Bearing module

## Reassembly

### Bearing module insertion

Refer to [Figure 9](#) on page 15.

1. Remove the new bearing module from its packaging.
2. Screw the bearing extractor sleeve onto the new bearing module.
3. Carefully insert the bearing module into the bearing cavity of the pump in reverse order of removal. Ensure that the bearing is pushed fully home.



**Note:**

The bearing anti-rotating tube may be used to prevent the bearing from rotating while the extractor sleeve is removed.

**Figure 9** Bearing module insertion

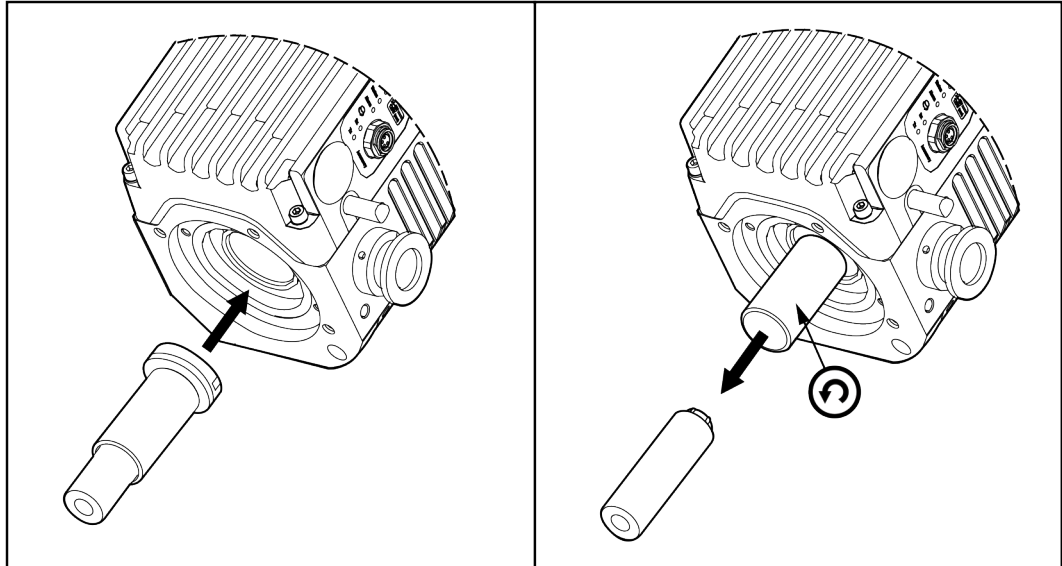

CS/1433/A

**Bearing retaining nut assembly**

Refer to [Figure 10](#) on page 15.

1. Using the combination of tools, engage the bearing retaining nut onto the pins of the pin spanner adaptor.
2. In reverse order of removal, fit the bearing retaining nut into position, taking care not to cross thread the nut. Torque the bearing retaining nut to 6 Nm.

**Figure 10** Bearing retaining nut assembly

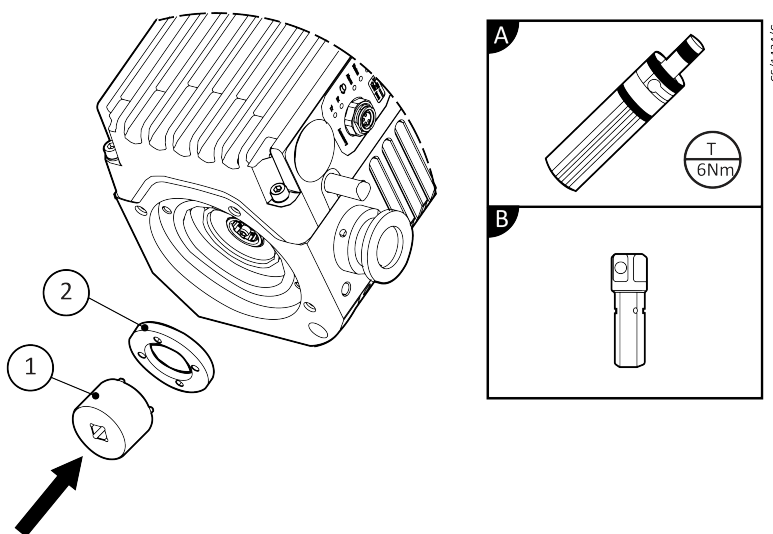

CS/1434/C

1. Pin spanner adaptor

2. Bearing retaining nut

## Tools

- A. Torque driver
- B. ¼" square drive

## Oil feed nut assembly

Refer to [Figure 11](#) on page 16.

1. Screw the oil feed nut onto the end of the shaft. This can be performed by hand.
2. Engage the T10 Torx bit with torque driver combination into the end of the oil feed nut.
3. Engage the T15 Torx screwdriver through the end of the shaft via the pump inlet.
4. While keeping the T15 Torx screwdriver stationary, torque the oil feed nut to 2 Nm.

**Figure 11** Oil feed nut assembly

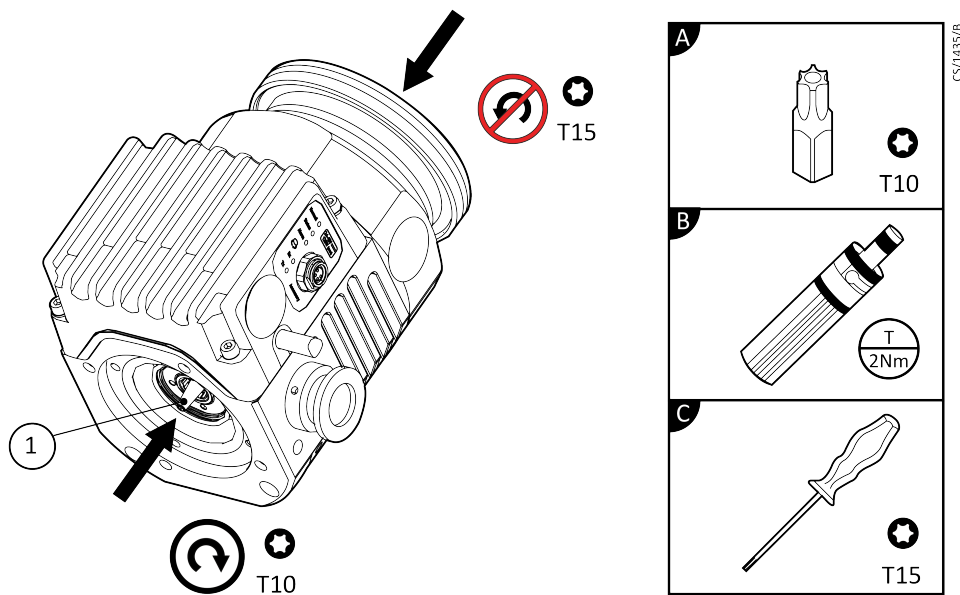

1. Oil feed nut

## Tools

- A. T10 Torx bit
- B. Torque driver
- C. T15 Torx screwdriver

## Oil cartridge assembly

Refer to [Figure 12](#) on page 17.

1. Carefully remove the new oil cartridge from its packaging.
2. Fit the oil cartridge into position while ensuring the fixing screw holes and threads are aligned.
3. Fasten the oil cartridge using the 4 x M4 button head screws previously removed. Evenly tighten each screw to 2 Nm.



**Note:**

If replacing the oil cartridge only, go straight to [Service counter reset](#) on page 18 after following this instruction.

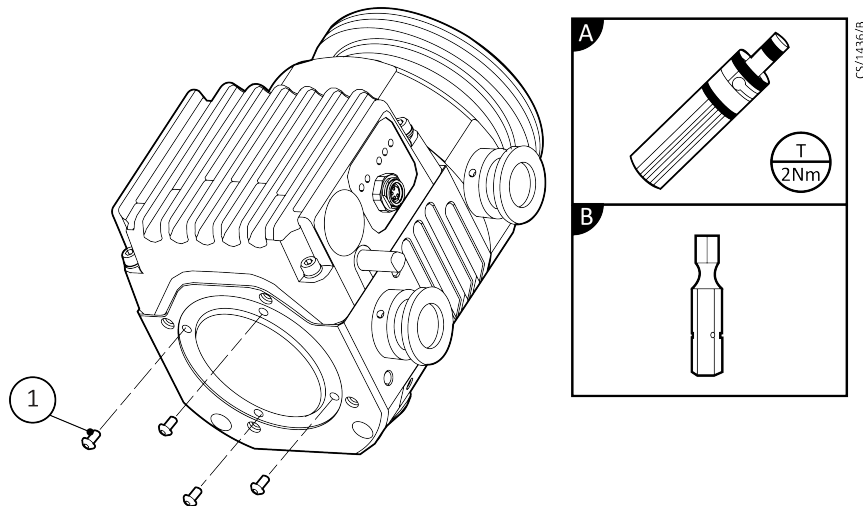
**Figure 12** Oil cartridge assembly

1. 4 x M4 button head screws

**Tools**

- A. Torque driver
- B. 4 mm hex bit

**Bearing preload check**

The bearing preload tool checks that the bearing preload force is correctly set. If necessary, the tool can be used to correct the bearing preload force if adjustment is required.

**CAUTION:**

**Bearing preload checking is required to check and if necessary set the bearing preload using the bearing preload tool. Failure to do so may shorten the service life of the pump.**

1. Fit and use the preload tool in accordance with pre-service [Preload check](#) on page 9. While performing this check, the position of the test indicator must be noted when a change in preload transition occurs. Refer to [Figure 13](#) on page 18.
2. If the test indicator falls within the pass limit, then no further action is required. Proceed to [Service counter reset](#) on page 18.
3. Adjustment of the bearing preload force will be required if the test indicator falls above or below the pass limit when a change in preload transition occurs. Using the preload tool body, rotate the magnetic bearing adjuster nut (viewed from top) clockwise if the test indicator is above the pass limit and anti-clockwise if the test indicator is below the pass limit.

It is advisable to monitor the preload force using the preload tool test plunger between 1 mm rotational increments. Continue this process until the test indicator

falls within the pass limit. When confident that the preload force has been correctly set, proceed to [Service counter reset](#) on page 18.

4. If no preload is detected, slowly turn the preload tool body clockwise until preload is established in accordance with [Preload check](#) on page 9. When the preload has been verified, measure the preload force by following the corresponding instructions above.

**Figure 13** Preload tool (pass / fail indication)

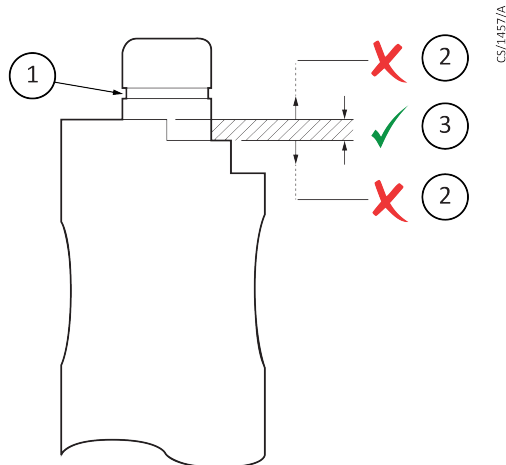

- |                              |         |
|------------------------------|---------|
| 1. Pass/ Fail test indicator | 3. Pass |
| 2. Fail                      |         |



**Note:**

*To check if the bearing is set to the correct preload force, the test indicator must be within the pass limits when the preload transition occurs.*

## Service counter reset

After completing an oil cartridge change or an oil cartridge and bearing module change, it is important to reset the service interval in order to schedule the next service and reset the status LED.

Depending on the set up and equipment availability, a choice of 4 options are available to perform a service counter reset.





Choose one of the following options:

1. Turbo instrument controller
2. PC serial command
3. nST PC program
4. nEXT turbo controller

**WARNING:**

Following a service counter reset the pump may enter a short setup / test routine. During this period some movement of the rotor may occur. To ensure safety of the user, in line with the product instruction manual, install the pump in the vacuum system before connecting the motor controller to the power supply. This will ensure that the pump cannot operate and injure people.

**Table 2** Front panel symbols and their functions

Symbol	Name	Function
	UP	Move up through a menu. Cycle selected numerical values up. Cycle a selected list item upwards.
	DOWN	Move down through a menu. Cycle selected numerical values down. Cycle a selected list item downwards.
	SELECT	Enter the highlighted sub menu. Edit the highlighted list or numerical item. Move to the next digit of a numerical value. Jump to the setup screen for the highlighted gauge or pump.
	MENU	Switch between the default view screen and the main menu. Exit the current sub menu or setup screen. Abort edit of a selected list item. Move to the previous digit of a numerical value.
	CYCLE	Turn a highlighted gauge or pump on or off.

### Reset the service interval using a Turbo Instrument Controller (TIC)

1. Starting from the top level view screen, press the **MENU** button to enter the MAIN menu.
2. Using the **DOWN** button, scroll down to the "Turbo Status" option then press the **SELECT** button to enter the TURBO STATUS menu.
3. Using the **DOWN** button, scroll down to the "Service menu - enter" option then press the **SELECT** button to enter the nEXT SERVICE menu.
4. Using the **DOWN** button, scroll down to the "Reset Service Due . . ." option then press the **SELECT** button to enter the nEXT SERVICE RESET menu.

5. Using the **DOWN** button, scroll down to the "Reset oil due" option then press the **SELECT** button to reset the oil service schedule. \*
6. To confirm that the service reset has been successful, press the **MENU** button to return to the nEXT SERVICE menu. Check that "run" and "until" hours have been reset. Check that the status LED has been reset and is no longer flashing.
7. Once the service counter reset has been completed, a power cycle must be performed to complete the process.

### Reset the service interval using a PC serial command

1. To reset the oil cartridge service interval following an oil cartridge change, send the following command over the serial communications link:

Command	!	C	8	8	6	sp	1	cr
---------	---	---	---	---	---	----	---	----

The reply received will be as follows:

Command	*	C	8	8	6	sp	1	cr
---------	---	---	---	---	---	----	---	----

To reset the bearing service interval following a bearing change, send the following command over the serial communications link:

Command	!	C	8	8	5	sp	1	cr
---------	---	---	---	---	---	----	---	----

The reply received will be as follows:

Command	*	C	8	8	5	sp	1	cr
---------	---	---	---	---	---	----	---	----

2. To confirm that the service reset has been successful, check that status LED has been reset and is no longer flashing.
3. Once the service counter reset has been completed, a power cycle must be performed to complete the process.

### Reset the service interval using a nST PC program

The nST PC program is PC-based software that can be used with the nEXT85 pump either via the serial interface or via the USB service port.

It can be used to control, monitor, configure and data log the nEXT85 pump and also to view service status, reset service intervals and upgrade the software embedded in the motor controller.

This software is available for download from the Edwards upgrades website:

[www.upgrades.edwardsvacuum.com](http://www.upgrades.edwardsvacuum.com)

Currently, nST software requires a free license in order to be used. To obtain a free license follow the on screen instructions, fill out the user data form and then send the automatically generated email to Edwards.

For first time users, referring to the nST Support Toolkit instruction manual D396-49-880 is recommended. The manual will give guidance on how to:

- Install the nST software application
- Register and activate the product

---

\* If the bearing module has also been replaced, then repeat the operation above by selecting the "Reset bearing due" option.

- Communicate with the nEXT85
- Perform a service reset

**Note:**

The oil cartridge and bearing service counter can be reset individually depending if one or both parts have been replaced.

To confirm that the service reset has been successful, check that status LED has been reset and is no longer flashing. Once the service counter reset has been completed, a power cycle must be performed to complete the process.

## Reset the service interval using the turbo drive standby speed control buttons

The service interval may be reset using the nEXT85 drive standby speed control buttons.

1. To proceed, ensure the drive is powered. Using a suitable implement such as the end of a ballpoint pen, press both the increase and decrease standby speed buttons simultaneously for more than 5 seconds.

**Note:**

This method will reset both the oil cartridge and bearing module service interval.

2. To confirm that the service reset has been successful, check that status LED has been reset and is no longer flashing. Once the service counter reset has been completed, a power cycle must be performed to complete the process.

**Figure 14** Motor controller status information

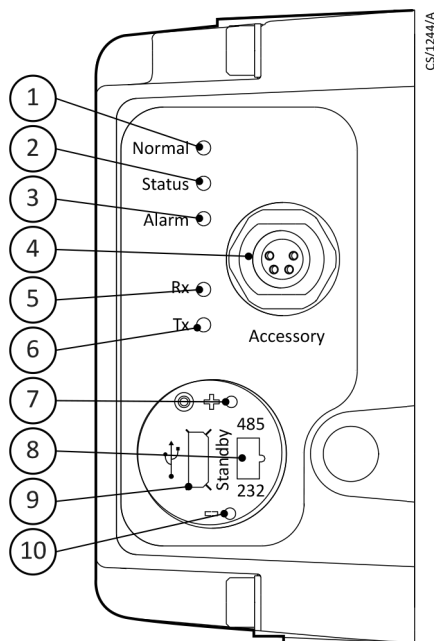

- |                        |                                   |
|------------------------|-----------------------------------|
| 1. Normal LED          | 6. Serial transmit LED            |
| 2. Status LED          | 7. Standby speed increase button  |
| 3. Alarm LED           | 8. RS232/RS485 slide switch       |
| 4. Accessory connector | 9. USB connector                  |
| 5. Serial receive LED  | 10. Standby speed decrease button |

## Pump checks



### **WARNING:**

**Ensure the pump is electrically isolated before performing any manual checks.**

Before running the pump, carrying out a number of checks is recommended. These checks are designed to ensure that the pump is in the best possible health with the limited test equipment that may be available.

### Clearance check

The first check ensures that the rotating and static parts are still in clearance. This can only be performed before installation.

Using the end of a pen for example, carefully rotate the rotor. While the rotor is spinning listen out for any clashing between the rotating and static parts. Ensure the rotor spins freely. If the rotor does not spin freely, contact your supplier.

**Figure 15** Clearance check

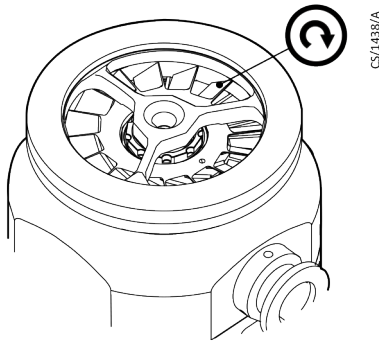

### Vacuum leak check

For a helium leak detector, leak checking the pump on the system against the specified system leak rate is highly recommended.

### Operational checks

Refer to the Operation section of the nEXT85 pump instructional manual B8G0-00-880.







This page has been intentionally left blank.

This page has been intentionally left blank.

## Return the equipment or components for service

Before you send your equipment to us for service or for any other reason, you must send us a completed Declaration of Contamination of Vacuum Equipment and Components - Form HS2. The HS2 form tells us if any substances found in the equipment are hazardous, which is important for the safety of our employees and all other people involved in the service of your equipment. The hazard information also lets us select the correct procedures to service your equipment.

We provide instructions for completing the form in the Declaration of Contamination of Vacuum equipment and Components - Procedure HS1.

If you are returning a vacuum pump, note the following:

- If a pump is configured to suit the application, make a record of the configuration before returning the pump. All replacement pumps will be supplied with default factory settings.
- Do not return a pump with accessories fitted. Remove all accessories and retain them for future use.
- The instruction in the returns procedure to drain all fluids does not apply to the lubricant in pump oil reservoirs.

Download the latest documents from [www.edwardsvacuum.com/HSForms/](http://www.edwardsvacuum.com/HSForms/), follow the procedure in HS1, fill in the electronic HS2 form, print it, sign it, and return the signed copy to Edwards.

**Note:** *If we do not receive a completed HS2 form, we will not accept the return of the equipment.*

