



Pascal 2005, I version, 3-Phase motor, 342–460 V, 50 Hz | 342–520 V, 60 Hz, CE/UL/CSA



Similar Image

**Pascal 2005, I version, 3-Phase motor, 342–460 V,
50 Hz | 342–520 V, 60 Hz, CE/UL/CSA**

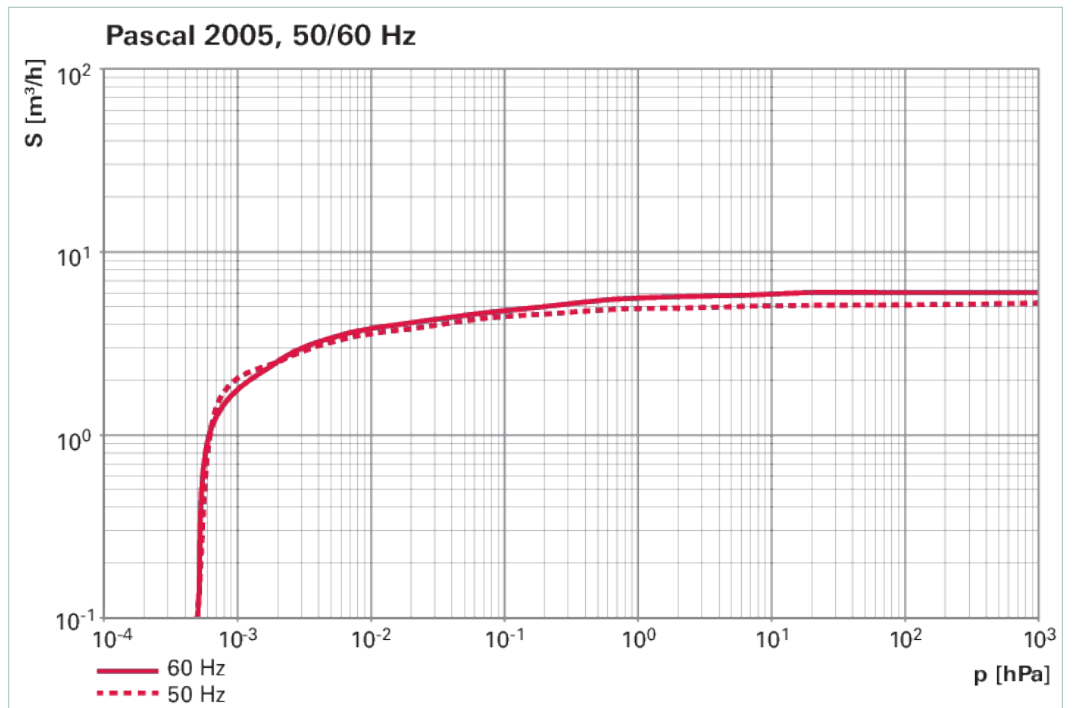
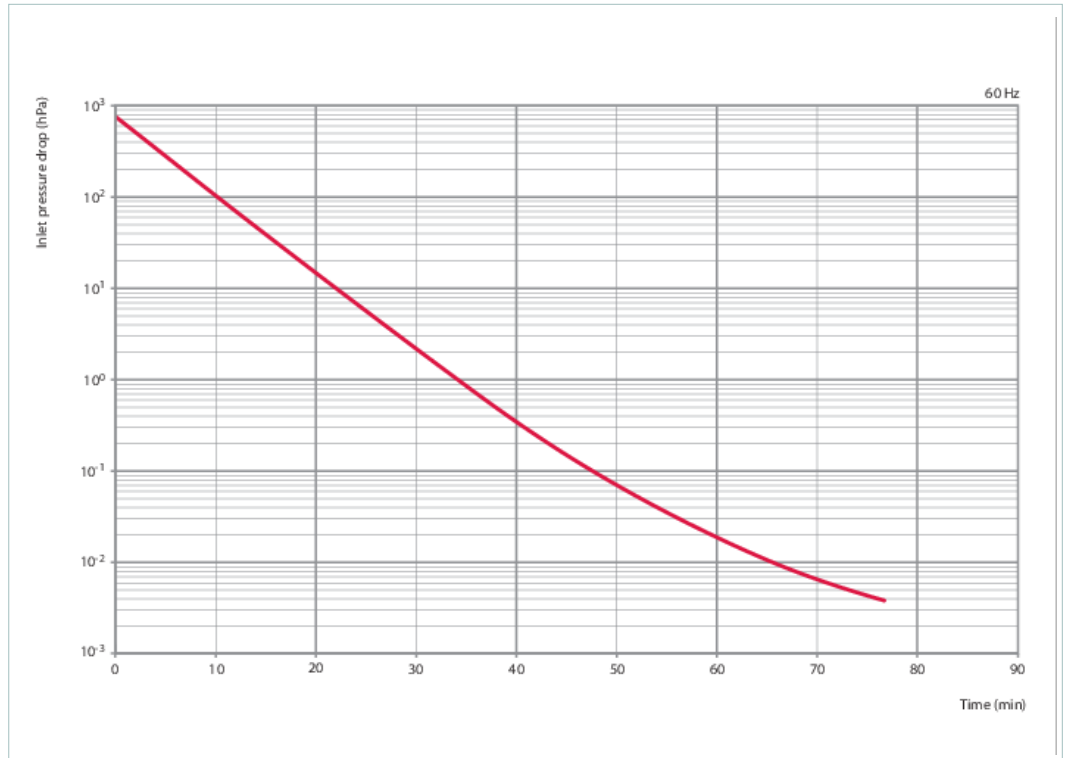

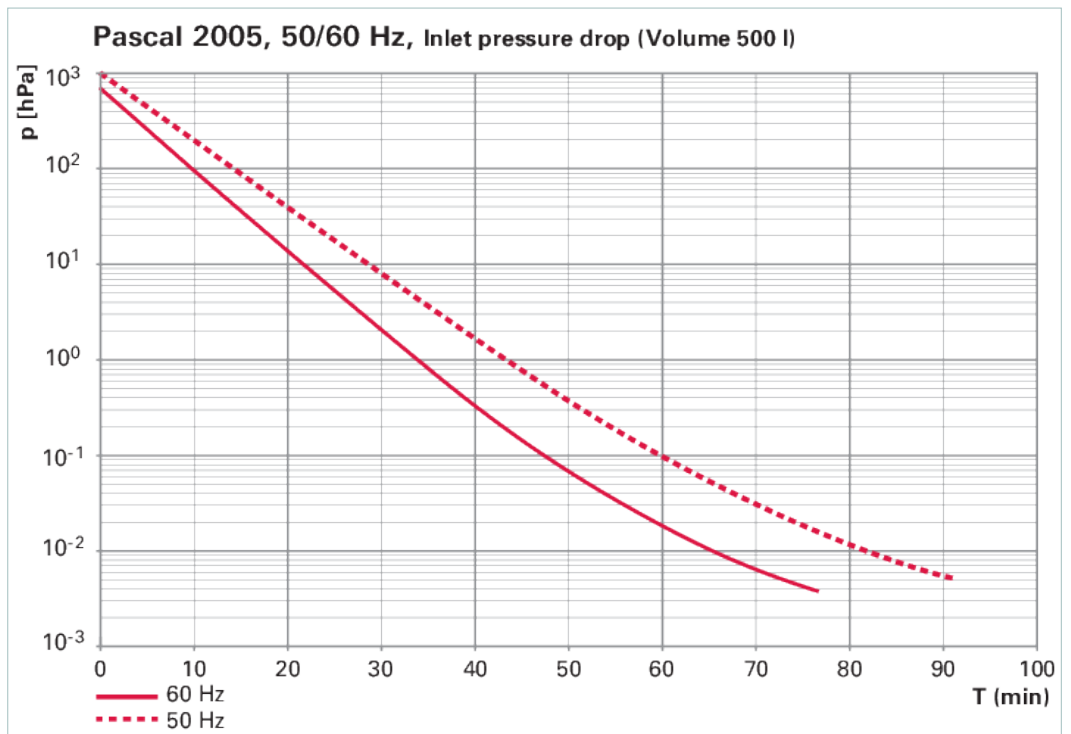

Dimensions

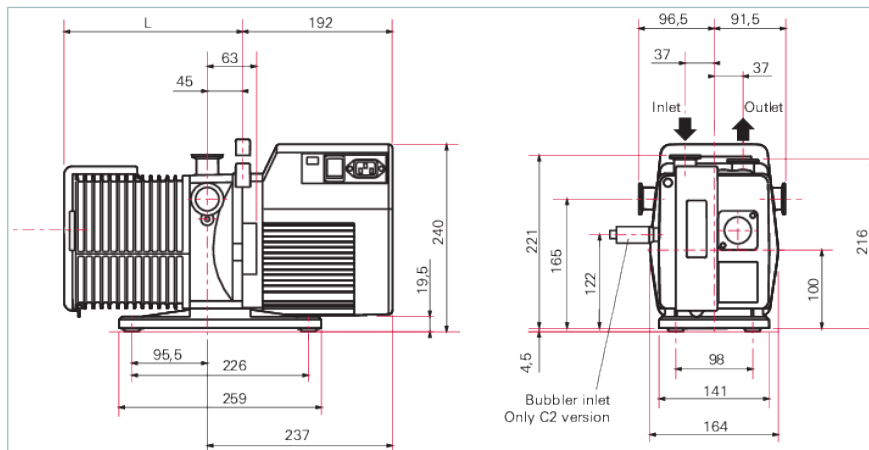

L 228 mm

Technical Data	
Pascal 2005, I version, 3-Phase motor, 342–460 V, 50 Hz 342–520 V, 60 Hz, CE/UL/CSA	
Connection flange (in)	DN 25 ISO-KF
Connection flange (out)	DN 25 ISO-KF
Pumping speed at 50 Hz	5 m ³ /h 2.94 cfm 83.33 l/min
Pumping speed at 60 Hz	6 m ³ /h 3.53 cfm 100 l/min
Final pressure	5 · 10 ⁻⁴ hPa 3.75 · 10 ⁻⁴ Torr 5 · 10 ⁻⁴ mbar
Final pressure with gas ballast	1 · 10 ⁻² hPa 7.5 · 10 ⁻³ Torr 1 · 10 ⁻² mbar
Final pressure without gas ballast	5 · 10 ⁻⁴ hPa 3.75 · 10 ⁻⁴ Torr 5 · 10 ⁻⁴ mbar
Motor type	3-ph motor
Mains connection: voltage 50 Hz	342 – 460 V
Mains connection: voltage 60 Hz	342 – 520 V
Mains cable	Yes, EU mains cable
Operating fluid	Mineral oil
Rated power 50 Hz	0.55 kW
Rated power 60 Hz	0.66 kW

Technical Data	Pascal 2005, I version, 3-Phase motor, 342–460 V, 50 Hz 342–520 V, 60 Hz, CE/UL/CSA
Protection degree	IP43
Weight	25 kg 55.12 lb
Order number	
Pascal 2005 I	205AETHEM

Accessories	
Connections Connection kits for mounting of pumps	
Connection kit for mounting pumps, DN 25 ISO-KF	120SWS025-1000
ISO-KF, welded bellows sealed	
HV angle valve, DN 25 ISO-KF, manually operated, 304/FKM, "A"-dim. 50 mm	ESV-S03100
Monitoring Oil/Operating fluid level monitoring	
Oil level switch OLS 4	104376
Monitoring Pressure Sensors	
OmniControl 200 with TPR 270	PT 440 950 -T
Protection Catalyzer traps	
URB 025, catalytic trap, 230 V	PT U10 760
URB 025, catalytic trap, 115 V	PT U10 761
Protection Cold traps	
Cold Trap, LN2, angled, DN 25 ISO-KF, 4" body, stainless steel / FPM	FTNA-4-1002-NWB
Protection Condensate separators	
KAS 25 L, condensate separator for pumping speeds up to 35 m ³ /h	PK Z10 033
Protection Dust separators/Inlet particle filters	
SAS 25, dust separator, DN 25 ISO-KF	PK Z60 508
Protection Oil mist eliminators	
Oil mist separator OME 25 S	104200
OME 25 M, oil mist separator for pumping speeds up to 12 m ³ /h	PK Z40 157
Protection Oil return units from oil mist eliminators	
Oil return unit ODK1 from oil mist separator	104360
Oil return unit ODK 2 from OME 25, solenoid valve 230 V 50/60 Hz, Pascal 2005–2021	104361
Oil return unit ODK 2 from OME 25, Pascal 2005–2021, solenoid valve 115 V, 60 Hz	104362
Oil return unit ODK 2 from OME 25, Pascal 2002–2021	104364
Oil return unit ODK 2 from OME 25, Pascal 2005–2021, solenoid valve 24 V DC	104365
Protection Sorption traps	
Sorption trap ST 25 S	104107
Valves Gas ballast valves, magnetic	
Automatic gas ballast AGB 4, 230 V, 50/60 Hz	104086
Automatic gas ballast AGB 4, 115 V	104087
Automatic gas ballast AGB 4, 24 VDC	104089
Automatic gas ballast AGB 4, 200 V, 50/60 Hz	104366
Valves Isolation valves	
AVC 025 PA, angle valve, electro-pneumatic, with PI, with PV, PV 24 V DC	PF A48 204
Consumables	
A120, hydrocarbon oil, 2 L	068099
A111, mineral oil, 2 L	064655
A102, hydrocarbon oil, 2 L	010996
A119, hydrocarbon oil, 1 L	103855
A121, hydrocarbon oil, 1 L	102724

VACUUM SOLUTIONS FROM A SINGLE SOURCE

Pfeiffer Vacuum stands for innovative and custom vacuum solutions worldwide, technological perfection, competent advice and reliable service.

COMPLETE RANGE OF PRODUCTS

From a single component to complex systems:

We are the only supplier of vacuum technology that provides a complete product portfolio.

COMPETENCE IN THEORY AND PRACTICE

Benefit from our know-how and our portfolio of training opportunities!

We support you with your plant layout and provide first-class on-site service worldwide.

Are you looking for a
perfect vacuum solution?
Please contact us:

Pfeiffer Vacuum GmbH
Headquarters · Germany
T +49 6441 802-0
info@pfeiffer-vacuum.de

www.pfeiffer-vacuum.com

All data subject to change without prior notice.

PFEIFFER  **VACUUM**