

# Instruction Manual

## Outlet Mist Filters and Catchpots

Description	Item Number
MF30 outlet mist filter	A46233000
MF100 outlet mist filter	A46203000
MF100AE outlet mist filter	A46211000
MF300 outlet mist filter	A46204000
MF300AE outlet mist filter	A46206000
CP100 outlet catchpot	A46103000
CP300 outlet catchpot	A46104000



## Copyright notice

©Edwards Limited 2021. All rights reserved.

## Trademark credits

Edwards and the Edwards logo are trademarks of Edwards Limited, Innovation Drive, Burgess Hill, West Sussex RH15 9TW.

## Disclaimer

The content of this manual may change from time to time without notice. We accept no liability for any errors that may appear in this manual nor do we make any expressed or implied warranties regarding the content. As far as practical we have ensured that the products have been de-signed and constructed to be safe and without risks when properly installed and used in accordance with their operating instructions.

We accept no liability for loss of profit, loss of market or any other indirect or consequential loss whatsoever.

Product warranty and limit of liability are dealt with in our standard terms and conditions of sale or negotiated contract under which this document is supplied.

You must use this product as described in this manual. Read the manual before you install, operate, or maintain the product.

# Contents

Section	Page
1	Introduction ..... 1
1.1	Scope and definitions ..... 1
1.2	Description ..... 1
1.2.1	MF30 mist filter ..... 1
1.2.2	MF100, MF100AE, MF300 and MF300AE mist filters ..... 3
1.2.3	CP100 and CP300 catchpots ..... 3
2	Technical Data ..... 5
2.1	Mist filters ..... 5
2.2	Catchpots ..... 6
3	Installation ..... 11
3.1	Unpack and inspect ..... 11
3.2	Install the MF30 mist filter ..... 11
3.3	Install the MF100 or MF100AE mist filter ..... 13
3.4	Install the MF300 or MF300AE mist filter ..... 15
3.5	Install the CP100 or CP300 catchpot ..... 15
4	Operation ..... 17
5	Maintenance ..... 19
5.1	Change the MF30 filter element ..... 19
5.2	Change the MF100, MF100AE, MF300 or MF300AE filter element ..... 20
5.3	Clean the CP100 or CP300 catchpot ..... 20
5.4	Replace the MF100AE or MF300AE sight-glass ..... 20
6	Storage and Disposal ..... 21
6.1	Storage ..... 21
6.2	Disposal ..... 21
7	Service, Spares and Accessories ..... 23
7.1	Introduction ..... 23
7.2	Service ..... 23
7.2.1	Return the equipment or components for service ..... 23
7.3	Spares ..... 24
7.4	Accessories ..... 24

# Illustrations

<b>Figure</b>	<b>Page</b>
1 MF30 oil mist filter .....	2
2 MF100 and MF100AE oil mist filters and CP100 catchpot .....	4
3 Dimensions (mm): MF30 oil mist filter .....	7
4 Dimensions (mm): MF100 and MF100AE oil mist filters and CP100 catchpot .....	8
5 Dimensions (mm): MF300 and MF300AE oil mist filters and CP300 catchpot .....	9
6 Installation of an MF30 oil mist filter onto an E2M28 pump .....	12
7 Installation of an MF100 oil mist filter or a CP100 catchpot onto an EM40 or an EM80 pump .....	14
8 Installation of an MF300 oil mist filter or a CP300 catchpot onto an EM175 or an EM275 pump .....	16

# Tables

<b>Table</b>	<b>Page</b>
1 Checklist of items .....	11

# 1 Introduction

## 1.1 Scope and definitions

This manual provides installation, operation and maintenance instructions for the following Edwards accessories:

- MF30, MF100, MF100AE, MF300 and MF300AE outlet mist filters
- CP100 and CP300 outlet catchpots

You must use these accessories as specified in this manual.

Read this manual before you install and operate the accessory. Important safety information is highlighted as WARNING and CAUTION instructions; you must obey these instructions. The use of WARNINGS and CAUTIONS is defined below.



### WARNING

Warnings are given where failure to observe the instruction could result in injury or death to people.

### CAUTION

Cautions are given where failure to observe the instruction could result in damage to the equipment, associated equipment and process.

The units used throughout this manual conform to the SI international system of units of measurement.

## 1.2 Description

Outlet mist filters separate and trap the oil mist which is discharged with the exhaust gases from oil-sealed rotary vacuum pumps when gas-ballast is used or when very high gas throughputs are pumped. The mist filter traps oil mist with an efficiency of better than 99.9%. The MF100AE mist filter is designed specifically for use with aggressive processes, for example with corrosive and toxic gases and vapours.

An oil return accessory kit is available for MF100 and MF300 mist filters to continuously return the trapped oil to the pump reservoir. You may use this accessory kit when the exhaust gases will not contaminate the pump oil. Refer to [Section 7](#).

Outlet catchpots fit into the pipeline between the pump-outlet and an external exhaust-extraction system. The catchpot traps any condensed liquids in the exhaust-extraction pipeline that could otherwise drain into the pump and contaminate it.

### 1.2.1 MF30 mist filter

Refer to [Figure 1](#) which shows the MF30 mist filter. Numbers in brackets in the following description refer to items shown on this figure.

The MF30 mist filter has a cast aluminium body (5). The filter element (12) is made from epoxy impregnated glass-fibre, stainless steel and nickel-plated mild steel.

The exhaust gases from the pump enter the inlet (13) of the filter and then pass down through the centre of the filter element. (The path of the exhaust gases through the filter is shown by the arrows in [Figure 1](#)).

The filter element separates and traps the oil mist and the trapped oil drains into the base of the mist filter. The oil-free exhaust gases are then discharged through the mist filter outlet (4).

The body of the mist filter has a sight-glass (8) so that you can see the level of oil trapped in the mist filter. The body also has a drain-plug (9) so that you can drain the trapped oil from the filter.

Figure 1 - MF30 oil mist filter

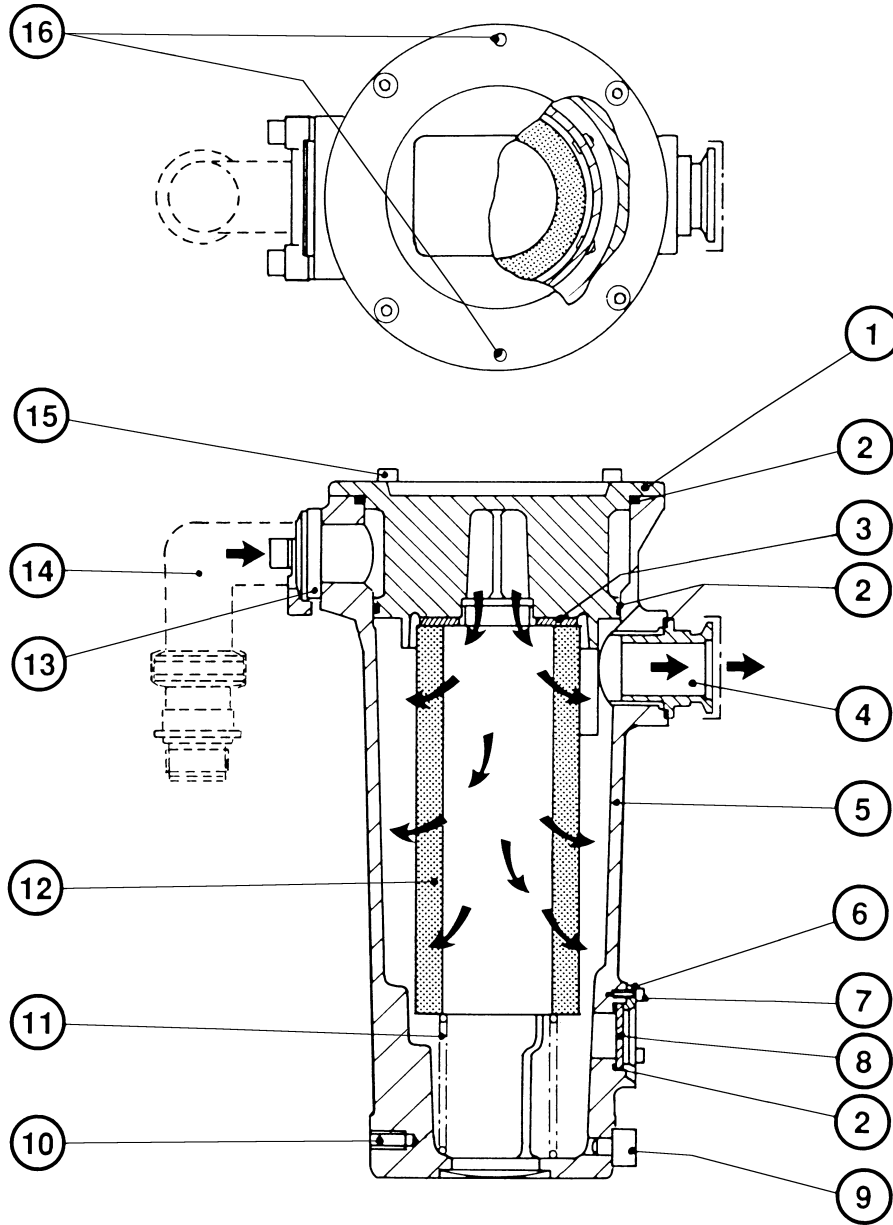

AG/0359/A

- |  |  |
|--|--|
| 1. Top-cover                                       | 9. Drain-plug and 'O' ring   |
| 2. 'O' ring  | 10. Support bolt hole  |
| 3. Gasket  | 11. Spring   |
| 4. Outlet fitted with<br>NW25 x 1 inch BSP adaptor | 12. Filter element   |
| 5. Body  | 13. Inlet fitted with 'C' clamp, blank flange,<br>screws and washers |
| 6. Sight-glass bezel                               | 14. Fitting-kit components   |
| 7. M3 x 8 screw and washer                         | 15. M5 screw and washer  |
| 8. Sight-glass                                     | 16. M5 'break' screw positions                                       |

### 1.2.2 MF100, MF100AE, MF300 and MF300AE mist filters

Refer to [Figure 2](#) which shows the MF100 and MF100AE mist filters. Numbers in brackets in the following description refer to items shown on this figure. The MF300 and MF300AE are larger but have a similar construction.

The filters have fine-pore filter elements (11) and a stainless steel wire-mesh filter element (3) inside the steel body (5). The MF100 and MF100AE have two fine-pore filter elements and the MF300 has four fine-pore filter elements.

The MF100AE is designed for use with corrosive and toxic gases and vapours. It is leak tested to  $1 \times 10^{-4}$  mbar.l.s<sup>-1</sup> ( $1 \times 10^{-2}$  Pa.l.s<sup>-1</sup>) and the filter elements, sight-glasses and seals are resistant to chemical attack.

The exhaust gases from the pump enter the inlet (17) of the filter and pass down through the filter elements (11) which separate and trap the oil mist. (The path of the exhaust gases through the filter is shown by the arrows in [Figure 2](#)).

The exhaust gases then pass through the stainless steel wire mesh element (3) which traps any large droplets of oil carried by the filtered gas. The oil-free exhaust gases are then discharged through the outlet (1). The trapped oil drains into the base of the body of the mist filter.

The mist filter has a sight-glass (10) so that you can see the level of oil trapped in the mist filter. The sight-glass indicates the maximum level at which the filter operates efficiently.

The sight-glass in the MF100 and MF300 mist filters is glued in position inside the body of the mist filter. The sight-glass in the MF100AE and MF300AE mist filters is secured in position by a bezel and 'O' rings. If necessary, you can replace the sight-glass in the MF100AE and MF300AE mist filters.

The body has a drain-valve (9) so that you can drain the trapped oil from the filter.

The spring-loaded pressure-relief valve (2) prevents a dangerous pressure build-up inside the pump and the body if the filter becomes blocked.

### 1.2.3 CP100 and CP300 catchpots

The body of the catchpot is identical to the body of the corresponding size mist filter (refer to [Figure 2](#)), but the catchpot does not have internal filter elements.

The catchpot has a sight-glass (12) which is glued in position inside the body of the catchpot. The sight-glass allows you to see the level of condensed liquid trapped in the catchpot. When the fluid level reaches the sight-glass (12), you must drain the oil from the catchpot through the drain valve (9).

Figure 2 - MF100 and MF100AE oil mist filters and CP100 catchpot (MF100 and MF100AE shown)

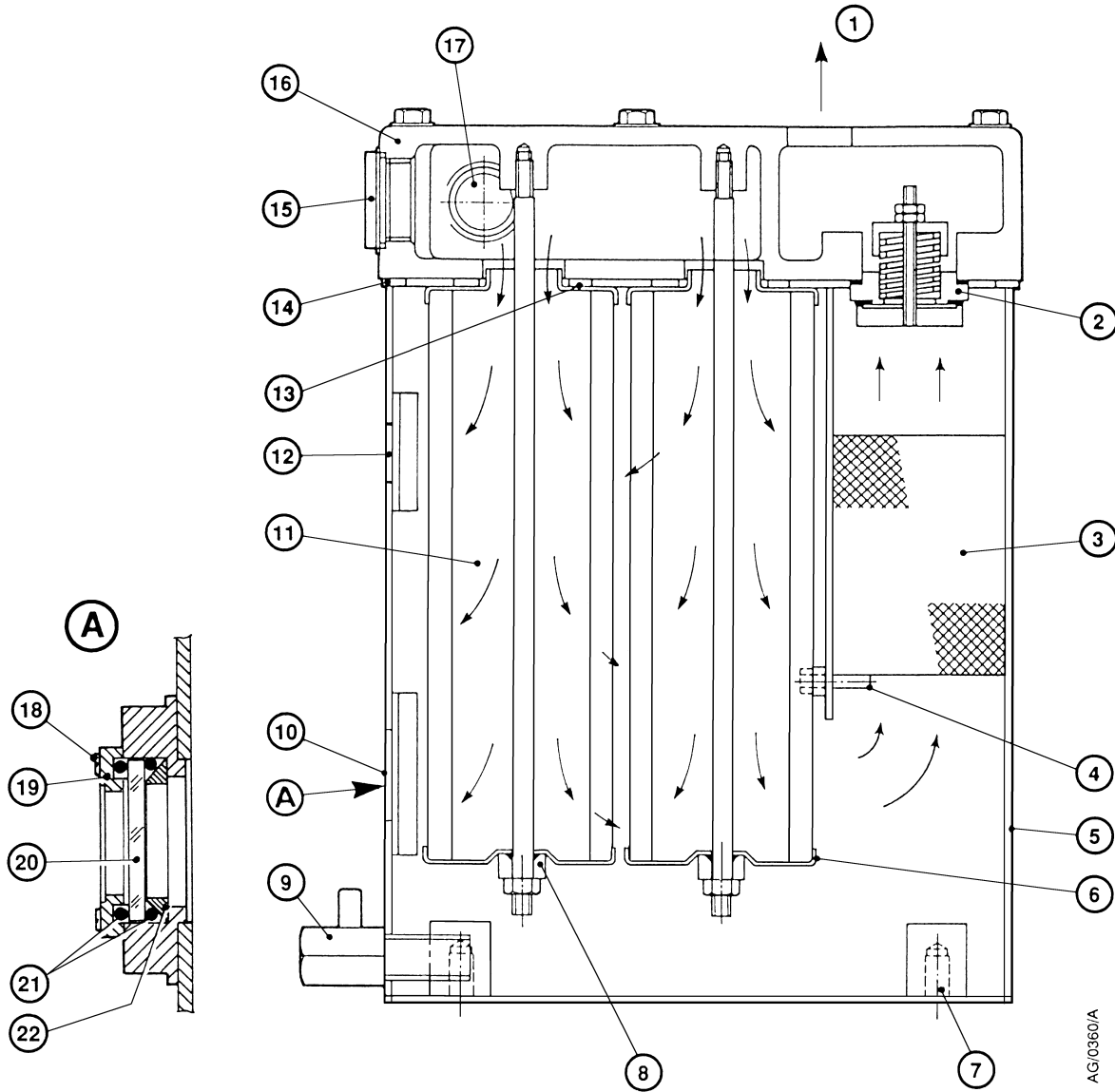

AG/0360/A

- |                                     |  |
|-------------------------------------|--|
| 1. Outlet                           | 12. Sight-glass (catchpots only)         |
| 2. Relief valve                     | 13. Gasket                               |
| 3. Wire mesh element                | 14. Top cover gasket                     |
| 4. Screw                            | 15. 1 inch BSP plug                      |
| 5. Body                             | 16. Top-cover                            |
| 6. Retaining plate                  | 17. Inlet                                |
| 7. Mounting-stud holes              | 18. Pan-head screw (4 off, MF100AE only) |
| 8. Nut                              | 19. Bezel (MF100AE only)                 |
| 9. Drain-valve                      | 20. Sight-glass (MF100AE only)           |
| 10. Sight-glass (mist filters only) | 21. 'O' rings (MF100AE only)             |
| 11. Element (mist filters only)     | 22. Compression ring (MF100AE only)      |



## 2 Technical Data

### 2.1 Mist filters

#### Dimensions

MF30	see Figure 3
MF100/MF100AE	see Figure 4
MF300/MF300AE	see Figure 5

#### Mass

MF30	1.3 kg
MF100/MF100AE	12 kg
MF300/MF300AE	28 kg

#### Filter material

MF30/MF100/MF300	Epoxy impregnated glass-fibre
MF100AE/MF300AE	Stainless steel mesh

#### Number of filter elements

MF30	1
MF100/MF100AE	2
MF300/MF300AE	4

#### Inlet and outlet ports

	Inlet	Outlet
MF30	NW25	NW25
MF100/MF100AE	NW25	1 inch BSP
MF300/MF300AE	ISO40	ISO40

#### Ambient temperature range (operation)

0 to 40 °C

#### Ambient temperature range (storage)

0 to 40 °C

#### Rated flow

MF30	30 m <sup>3</sup> h <sup>-1</sup>
MF80	80 m <sup>3</sup> h <sup>-1</sup>
MF300	275 m <sup>3</sup> h <sup>-1</sup>

#### Relief pressure

0.35 bar, 3.5 x 10<sup>4</sup> Pa

#### For use with Edwards rotary pumps

MF30	E2M28
MF100/MF100AE	E1M40, E1M80, E2M40, E2M80 and Superpumps
MF300/MF300AE	E1M175, E1M275, E2M175, E2M275

#### Leak-tightness (MF100AE/MF300AE)

1 x 10<sup>-4</sup> mbar.l.s<sup>-1</sup>, 1 x 10<sup>-2</sup> Pa.l.s<sup>-1</sup>

## 2.2 Catchpots

### Dimensions

CP100 see Figure 4

CP300 see Figure 5

### Mass

CP100 12.0 kg

CP300 28.0 kg

### Capacity

CP100 6.5 l

CP300 23.0 l

### Inlet and outlet port size

	<b>Inlet</b>	<b>Outlet</b>
CP100	NW25	1 inch BSP
CP300	NW40	NW40

### For use with Edwards rotary pumps

CP100 E1M40, E1M80, E2M40, E2M80 and Superpumps

CP300 E1M175, E1M275, E2M175, E2M275

Figure 3 - Dimensions (mm): MF30 oil mist filter

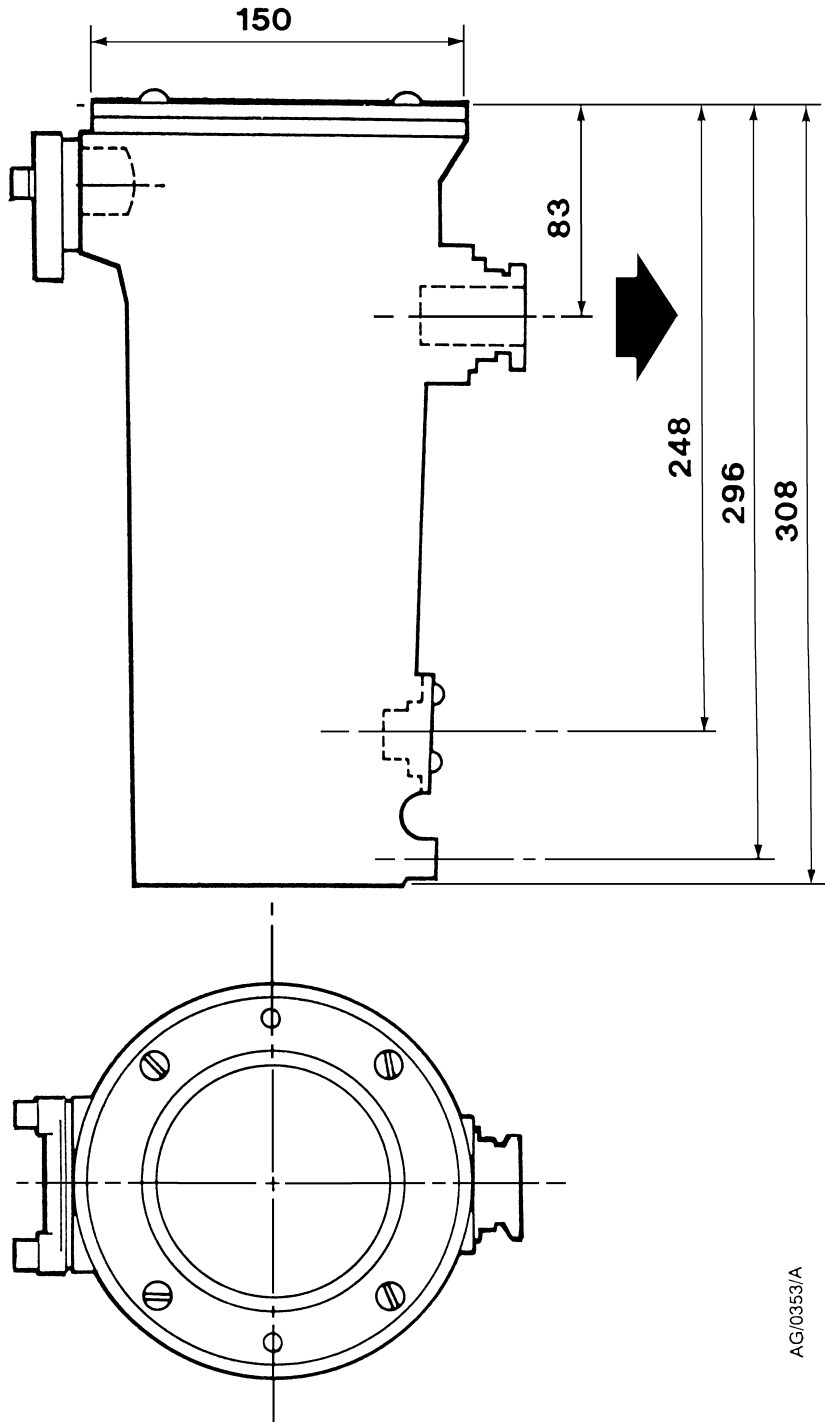

AG/0353/A

Figure 4 - Dimensions (mm): MF100 and MF100AE oil mist filters and CP100 catchpot (MF100 shown)

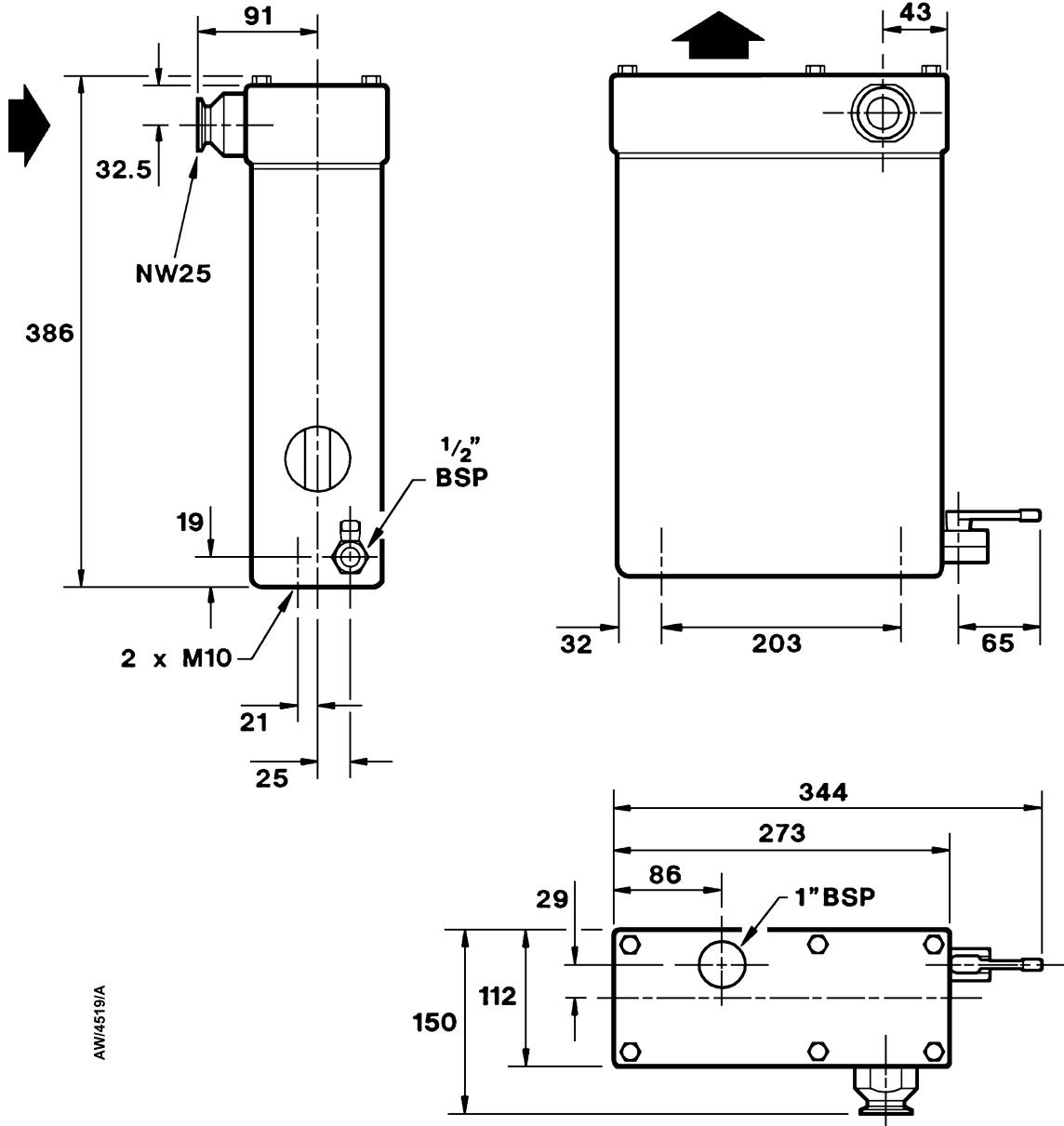

AW/4519/A

- 1. Fixing hole: 2 x M10

Figure 5 - Dimensions (mm): MF300 and MF300AE oil mist filters and CP300 catchpot (MF300 shown)

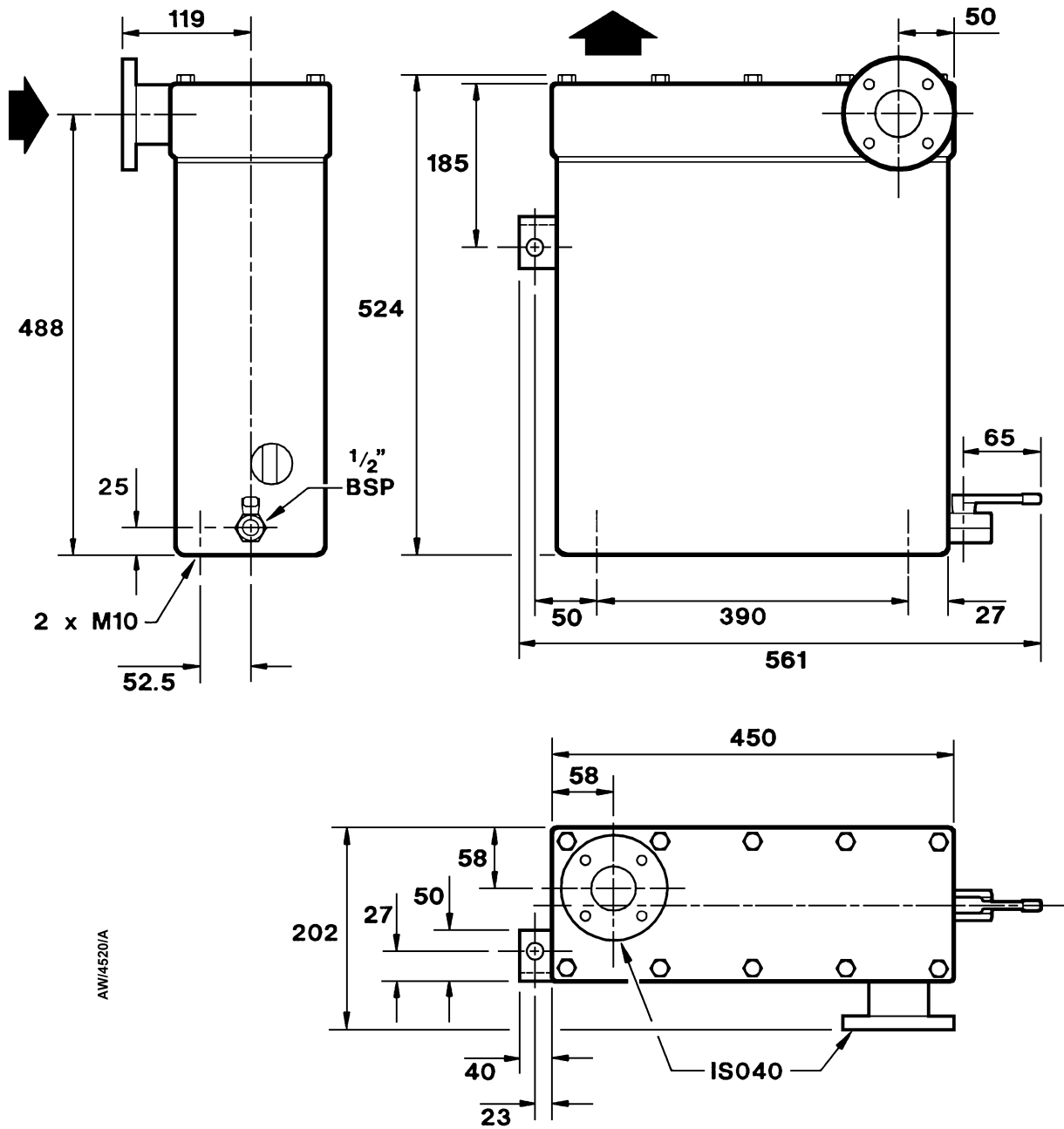

AWI4520/A

This page has been intentionally left blank.

## 3 Installation



### WARNING

You must remove the protective cover from the outlet of the filter or catchpot. A dangerous build-up of pressure can occur if the outlet is blocked.

### 3.1 Unpack and inspect

Remove all packing materials and inspect your accessory.

If your accessory is damaged, notify your supplier and the carrier in writing within three days; state the Item Number of the accessory together with your order number and your supplier's invoice number. Do not use the accessory if it is damaged.

Check that your package contains the items shown in [Table 1](#). If any of the items is missing, notify your supplier in writing within three days.

Table 1 - Checklist of items

Qty	Description	Check ( )
1	Oil Mist Filter or Catchpot	
1	Fitting pack	
1	'O' ring	

If the accessory is not to be used immediately, return it to its protective packaging. Store the accessory in clean dry conditions, away from direct sources of heat and sunlight.

### 3.2 Install the MF30 mist filter

Refer to [Figure 6](#) for items in brackets. You must install the MF30 filter vertically with the exhaust flow in the direction of the arrows on the top-cover (1).

1. Clean the area around the pump-outlet.
2. Unscrew and remove the outlet connector from the pump.
3. Fit the NW25 x  $\frac{3}{4}$  inch BSP adaptor (4) supplied in the fitting kit in place of the outlet connector. Reuse the original 'O' ring from the outlet connector if it is in good condition. If necessary, fit a new 'O' ring.
4. Undo the 'C' clamp (2) on the mist filter and remove the blanking plate and Co-Seal.
5. Use the 'C' clamp and Co-Seal (2) to connect the elbow (3) to the MF30 filter.
6. Use the clamping ring and centring-ring (4) to fit the elbow (3) to the pump-outlet adaptor (5).
7. To support the filter, fit the M8 bolt and locknut (7) from the fitting kit into the threaded hole near the base of the MF 30 filter (8). Adjust the bolt until it touches the side of the pump and then tighten the locknut.
8. If necessary, fit an exhaust pipeline to the outlet of the filter (9).

Figure 6 - Installation of an MF30 oil mist filter onto an E2M28 pump

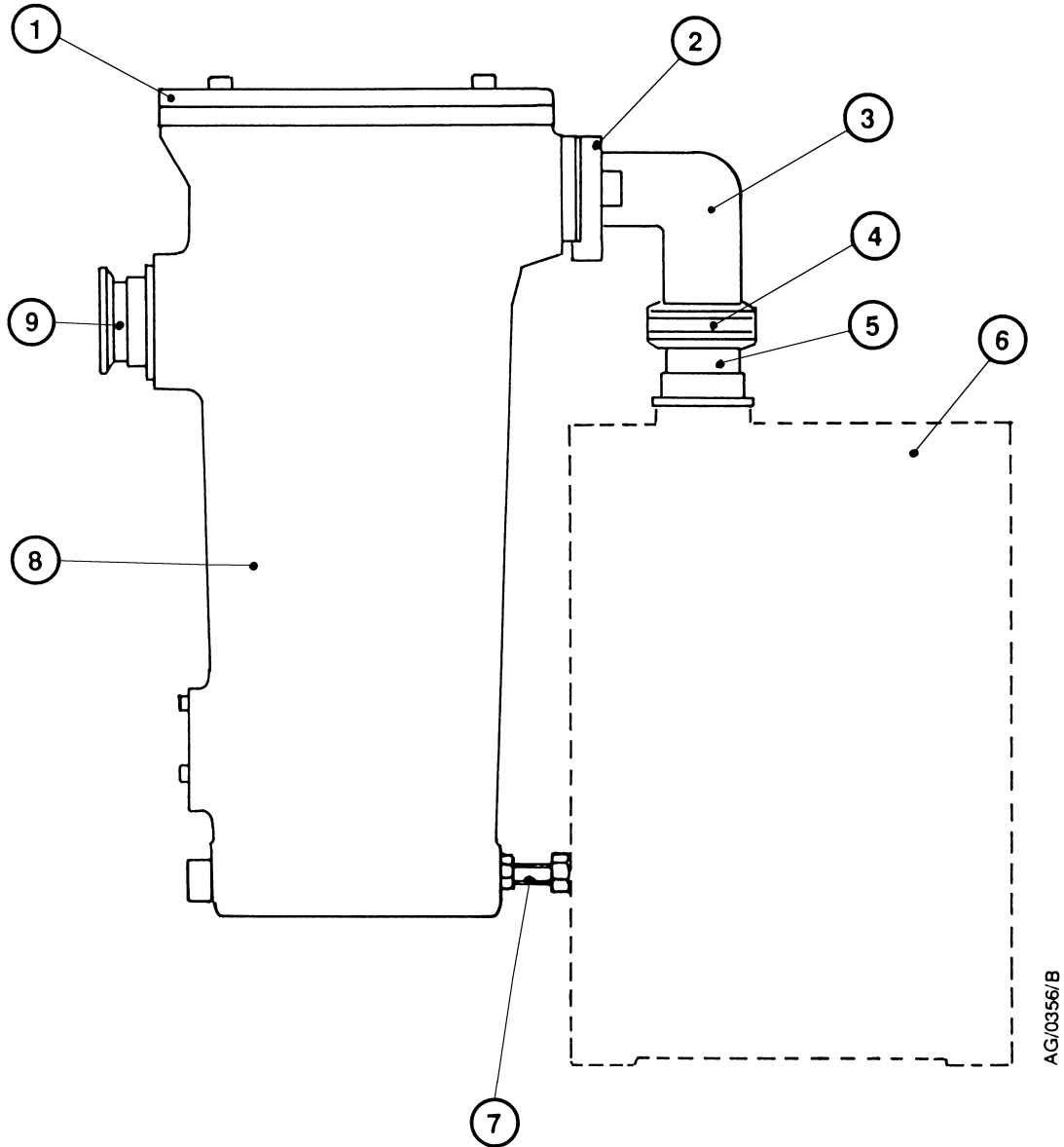

- |                                    |                              |
|------------------------------------|------------------------------|
| 1. Top-cover and gasket            | 6. E2M28 pump (shown dotted) |
| 2. NW25 'C' clamp and Co-Seal      | 7. M8 bolt and locknut       |
| 3. NW25 elbow                      | 8. MF30 filter               |
| 4. Clamping ring and centring-ring | 9. Filter outlet             |
| 5. Pump-outlet adaptor             |                              |



### 3.3 Install the MF100 or MF100AE mist filter

Refer to [Figure 7](#) and use the following procedure to install the filter:

1. Clean the area around the pump-outlet.
2. Fit the support bracket (1) to the pump runner with the spacers (2) and the screws and washers (9, 11) supplied.
3. Screw the two studs (14 or 15) into the threaded holes in the filter base. Use the shorter pair of studs (14) for an EM40 pump; use the longer pair of studs (15) for an EM80 pump. Fit one nut on each stud, about 30 mm from the free end of the stud.
4. Fit the NW25 elbow (4) to the pump-outlet with the two screws, centring-ring and 'O' ring supplied with the pump.
5. Place a washer (12) at the end of each stud (14, 15) and lower the filter so that the studs pass through the holes in the support bracket (1). Adjust the nuts so that the filter is level and the filter flange is aligned with the elbow (4).
6. Secure the studs to the support bracket with two washers and nuts and connect the filter-inlet to the elbow with the centring-ring (5), the 'O' ring (6) and the clamp (3) supplied in the fitting kit.
7. Tighten all the screws and nuts securely. Check that the drain-valve ([Figure 2](#), item 9) is fitted and closed.
8. If necessary, fit an exhaust pipeline to the outlet of the filter.

Figure 7 - Installation of an MF100 oil mist filter or a CP100 catchpot onto an EM40 or an EM80 pump

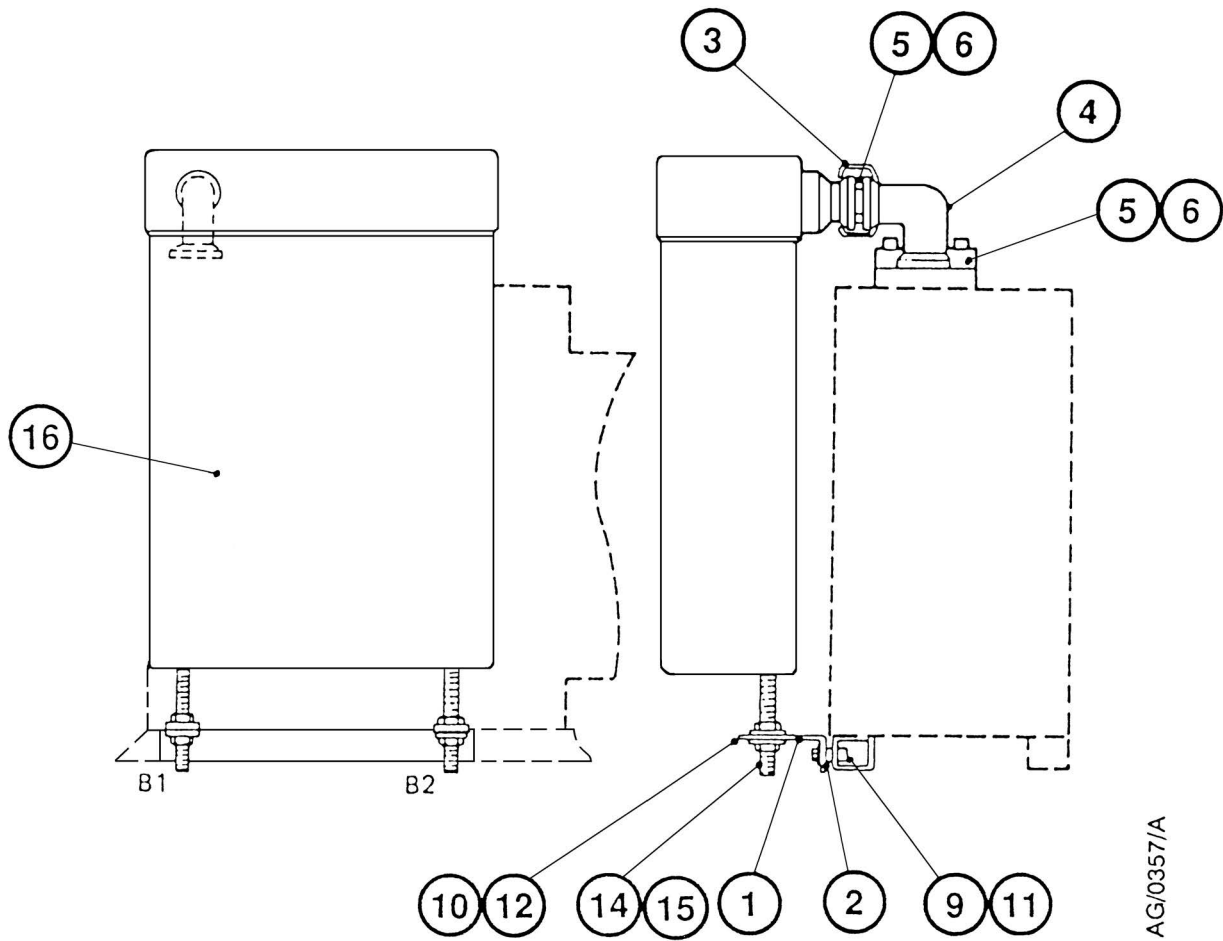

AG/0357/A

- |                       |                                    |
|-----------------------|------------------------------------|
| 1. Support bracket    | 9. M8 x 35 screw                   |
| 2. Spacer             | 10. M10 nut                        |
| 3. NW25 clamp         | 11. M8 washer                      |
| 4. NW25 elbow         | 12. M10 washer                     |
| 5. NW25 centring-ring | 13. Not used                       |
| 6. 'O' ring           | 14. M10 x 110 stud                 |
| 7. Not used           | 15. M10 x 140 stud                 |
| 8. Not used           | 16. MF100 filter or CP100 catchpot |

### 3.4 Install the MF300 or MF300AE mist filter

Refer to [Figure 8](#) for items in brackets. All of the items you require to install the filter are included in the fitting pack.

1. Clean the area around the pump-outlet.
2. Fit the lower support bracket (2) to the pump runner with the two screws and washers (8, 10) supplied.
3. Screw the two studs (9) into the threaded holes in the filter base. Fit one nut on each stud, about 30 mm from the free end of the stud.
4. Fit the NW40 elbow (3) to the pump-outlet with the flange seal pack (6), 'C' clamp (4), screws (7) and washers (13) supplied in the fitting pack.
5. Place a washer (10) at the end of each stud (9) and lower the filter so that the studs pass through the holes in the lower support bracket (2). Adjust the nuts so that the filter is level and the filter flange is aligned with the elbow (3).
6. Secure the studs to the support bracket with two washers and nuts and fit the upper support bracket (1) to the pump and the filter.
7. Connect the filter-inlet to the elbow with the flange seal pack (6), 'C' clamp (4), screws (15), washers (13) and nuts (14) supplied in the fitting kit.
8. Tighten all the screws and nuts securely. Check that the drain-valve ([Figure 2](#), item 9) is fitted and closed.
9. If necessary, fit an exhaust pipeline to the outlet of the filter.

### 3.5 Install the CP100 or CP300 catchpot

The procedure is identical to that for the MF100 or MF300 filter, as described in [Sections 3.3](#) and [3.4](#).

Figure 8 - Installation of an MF300 oil mist filter or a CP300 catchpot onto an EM175 or an EM275 pump

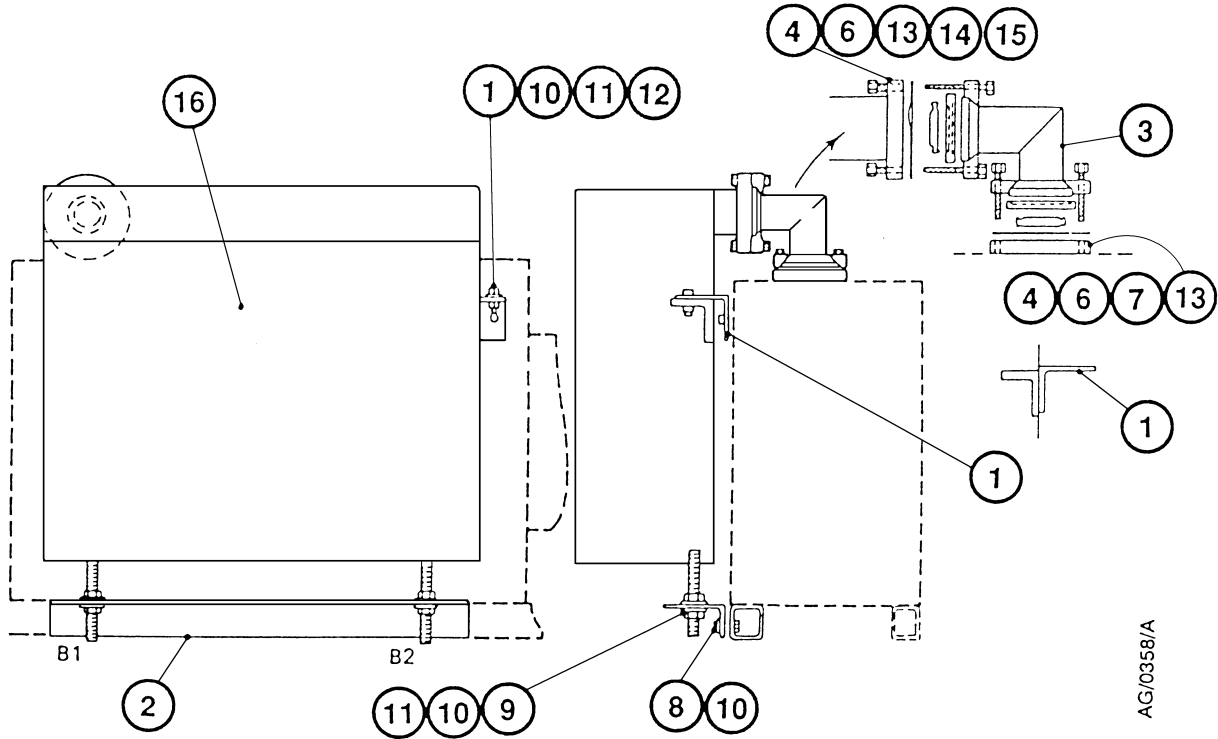

AG/0358/A

- |                             |                                    |
|-----------------------------|------------------------------------|
| 1. Upper support bracket    | 9. M10 x 90 stud                   |
| 2. Lower support bracket    | 10. M10 washer                     |
| 3. NW40 elbow               | 11. M10 nut                        |
| 4. NW40 'C' clamp           | 12. M10 x 30 screw                 |
| 5. Not used                 | 13. M8 washer                      |
| 6. Size 40 flange seal pack | 14. M8 nut                         |
| 7. M8 x 35 screw            | 15. M8 x 40 screw                  |
| 8. M10 x 40 screw           | 16. MF300 filter or CP300 catchpot |

## 4 Operation



### WARNING

If the oil is contaminated, the filter may become clogged. If the filter is clogged, the relief valve will open and oil mist will be discharged directly to the exhaust of the mist filter. You must replace the filter element if it becomes clogged.

- Check the oil-level in the filter or catchpot regularly.
- The sight-glass may become opaque if it is contaminated by certain process chemicals in the pump oil; we recommend that you drain the oil regularly to prevent this. You **must** drain the oil before the level reaches the maximum mark on the sight-glass. The rate of oil collection will depend on your process application.
- Check the oil-level in the pump when you check the filter or catchpot. Oil trapped in the filter or catchpot has been lost by the pump.
- If you need to drain the filter very frequently, a continuous oil return kit is available for the MF100 and MF300 mist filters; see [Section 7](#).

This page has been intentionally left blank.

## 5 Maintenance



### WARNING

Avoid contact with components contaminated with dangerous substances which have been pumped through your vacuum system. Wear protective clothing when you come into contact with contaminated filters and filter elements.



### WARNING

Isolate the pump from the electrical supply before you start maintenance.

### 5.1 Change the MF30 filter element

Refer to [Figure 1](#) for items in brackets.

1. Place a suitable container under the filter drain-plug (9). Remove the drain-plug and drain any trapped oil, then refit the drain-plug.
2. Use a 4mm hexagon key to remove the 4 retaining screws (15) from the top-cover (1).
3. Fit two of the screws into the 'break' screw positions (16) in the top-cover. Hold the top-cover down (it is under internal spring pressure) and gently turn the screws clockwise to prise the top-cover (1) away from the filter-body (5).
4. Remove the top-cover and inspect the 'O' rings (2). If necessary, replace the 'O' rings.
5. Lift out the element (12) and the top-gasket (3) and dispose of them safely. A new top-gasket is supplied with the new element.
6. Wash the interior with a suitable cleaning solution. Replace any 'O' rings, seals or gaskets which are damaged.
7. Insert the new element and gasket and centralise the element on the spring (11).
8. Reposition the top-cover so that the element top-collar locates into the recess in the cover and the baffle plate is next to the outlet-port (4).
9. Press the assembly down and secure it with the four screws and washers. Tighten the screws evenly to ensure a leak-tight joint.

## 5.2 Change the MF100, MF100AE, MF300 or MF300AE filter element

Refer to [Figure 2](#) for items in brackets.

1. Place a suitable container under the filter drain-valve (9). Open the drain-valve and drain any trapped oil, then close the drain-valve.
2. Disconnect the filter-inlet and outlet connections.
3. Remove the screws from the top-cover (16) and remove the top-cover and the filter element(s) (11) from the filter-body (5).
4. Remove the nuts (8) and the retaining plate (6) from the studs which hold the filter element(s) to the top-cover. Remove the filter element(s) and dispose of them safely.
5. Wash the interior and the stainless steel mesh filter element (3) with a suitable cleaning solution. Replace any 'O' rings, seals or gaskets which are damaged.
6. Fit the replacement filter element(s) onto the studs and refit the retaining plate and nuts. Tighten the nuts sufficiently to provide an effective seal. Do not overtighten the nuts.
7. Refit the top-cover and filter(s) onto the filter-body and secure the assembly with the screws. Reconnect the filter-inlet and outlet connections.

## 5.3 Clean the CP100 or CP300 catchpot

Refer to [Figure 2](#) for items in brackets.

1. Place a suitable container under the catchpot drain-valve (9). Open the drain-valve and drain any trapped oil, then close the drain-valve.
2. Disconnect the catchpot-inlet and outlet connections.
3. Undo the retaining screws, remove the top-cover (16) from the catchpot and examine the interior of the catchpot.
4. If necessary, wash the interior with a suitable cleaning solution. Replace any 'O' rings, seals or gaskets which are damaged.
5. Refit the top-cover onto the catchpot and secure it with the screws. Reconnect the inlet and outlet connections to the catchpot.

## 5.4 Replace the MF100AE or MF300AE sight-glass

If necessary, you can replace the sight-glass in the MF100AE and MF300AE oil mist filters; refer to [Figure 2](#) and use the following procedure:

1. Drain the oil from the filter: refer to Step 1 of [Section 5.2](#).
2. Undo and remove the four pan-head screws (18) which secure the sight-glass bezel (19) to the mist filter.
3. Remove the bezel, the outer 'O' ring (21) and the sight-glass (20).
4. Locate the new sight-glass in place.
5. Refit the outer 'O' ring (21, removed in Step 2).
6. Refit the bezel (19) and secure with the four pan-head screws (18).



## 6 Storage and Disposal

### 6.1 Storage

Store the accessory as described below.

1. Refit protective covers over the inlet and outlet ports.
2. Place the accessory in its protective packaging.
3. Store the accessory in a cool dry place until required.
4. When required for use, prepare and install the accessory as described in [Section 3](#).

### 6.2 Disposal

Dispose of the accessory and any components removed from it safely in accordance with local and national safety and environmental requirements.

Particular care must be taken with components and oil which have been contaminated with dangerous substances.

This page has been intentionally left blank.

## 7 Service, Spares and Accessories

### 7.1 Introduction

Edwards products, spares and accessories are available from Edwards companies in Belgium, Brazil, Canada, France, Germany, Hong Kong, Italy, Japan, Korea, Switzerland, United Kingdom, U.S.A. and a world-wide network of distributors. The majority of these centres employ Service Engineers who have undergone comprehensive Edwards training courses.

Order spare parts and accessories from your nearest Edwards company or distributor. When you order, please state for each part required:

- Model and Item Number of your equipment
- Serial number (if any)
- Item Number and description of part

### 7.2 Service

Edwards products are supported by a world-wide network of Edwards Service Centres. Each Service Centre offers a wide range of options including: equipment decontamination; service exchange; repair; rebuild and testing to factory specifications. Equipment which has been serviced, repaired or rebuilt is returned with a full warranty.

Your local Service Centre can also provide Edwards engineers to support on-site maintenance, service or repair of your equipment.

For more information about service options, contact your nearest Service Centre or other Edwards company.

#### 7.2.1 Return the equipment or components for service

Before you send your equipment to us for service or for any other reason, you must send us a completed Declaration of Contamination of Vacuum Equipment and Components - Form HS2. The HS2 form tells us if any substances found in the equipment are hazardous, which is important for the safety of our employees and all other people involved in the service of your equipment. The hazard information also lets us select the correct procedures to service your equipment.

We provide instructions for completing the form in the Declaration of Contamination of Vacuum equipment and Components - Procedure HS1.

Download the latest documents from [www.edwardsvacuum.com/HSForms/](http://www.edwardsvacuum.com/HSForms/), follow the procedure in HS1, fill in the electronic HS2 form, print it, sign it, and return the signed copy to Edwards.

*If we do not receive a completed HS2 form, your equipment cannot be serviced.*

### 7.3 Spares

Description	Item Number
MF30 mist filter element	A22304057
MF100 mist filter element (2 required)	A22304020
MF100 mist filter spares kit (element and seals)	A46203800
MF100AE mist filter element (2 required)	A22304052
MF300 mist filter element (4 required)	A22304021
MF300 mist filter spares kit (element and seals)	A46204800
MF300AE mist filter element (4 required)	A22304003

### 7.4 Accessories

Description	Item Number
Oil return pack for MF100 mist filter	A50004000
Oil return pack for MF300 mist filter	A50005000

