

Rotary Vane Pumps



UNO/DUO 250 A

Index

	Page
1. Safety Precautions	3
1.1. For Your Orientation.....	3
1.2. Pictogram Definitions.....	3
2. Understanding The Pumps.....	4
2.1. Main Features.....	4
2.2. Differences Between The Pump Types.....	4
3. Installation	5
3.1. Preparations For Installation.....	5
3.2. Pump Assembly And Location	5
3.3. Connecting The Vacuum Side.....	5
3.4. Connecting The Exhaust Side	5
3.5. Connecting To The Mains Power Supply.....	6
3.6. Special Models.....	9
4. Operations	10
4.1. Filling Up And Checking The Operating Fluid	10
4.1.2. Operating Fluid F5	10
4.2. Switching The Pump ON And OFF.....	11
4.3. Operating The Pump With Gas Ballast Valve.....	11
4.3.1. Standard Model.....	11
4.3.2 Corrosive Gas Model	11
4.4. Pumping Off Dry Gases	12
4.5. Pumping Off Vapours.....	12
5. What To Do In Case Of Breakdown.....	12
6. Maintenance	13
6.1. Changing The Operating Fluid.....	13
6.2. Cleaning The Oil Filter	13
6.3. Re-Setting The Silencer	14
6.4. Cleaning The Gas Ballast Valve.....	15
6.5. Cleaning The Silencer	15
6.6. Shutting Down For Longer Periods	17
7. Service	18
8. Technical Data	19
8.1. Dimensions.....	20
9. Accessories.....	20
10. Spare Parts	20
Declaration Of Contamination	21
Declaration Of Conformity	(last page)

Please note:

Current operating instructions are also available via www.pfeiffer-vacuum.net.

Modifications reserved

1. Safety Precautions

- ☞ Read and follow all the instructions in this manual.
- ☞ Inform yourself regarding:
 - ☞ Hazards which can be caused by the pump;
 - ☞ Hazards which can arise in your system;
 - ☞ Hazards which can be caused by the medium being pumped.
- ☞ Avoid exposing any part of your body to vacuum.
- ☞ Observe all safety and accident prevention regulations.
- ☞ Check regularly that all safety requirements are being complied with.
- ☞ Do not carry out any unauthorised conversions or modifications on the pump.
- ☞ When returning the pump to us please note the shipping instructions in Section 7.

1.1. For Your Orientation

Instructions in the text

- ➔ Operating instructions: Here, you have to do something

Symbols Used

The following symbols are used throughout in the illustrations:

- Ⓟ Vacuum-flange
- Ⓛ Exhaust flange
- Ⓞ Gas ballast
- ⚡ Power connection

Position-Numbers

Identical pump and accessory parts have the same position numbers in all illustrations.

1.2. Pictogram Definitions



Danger of personal injury.



Danger of injury from moving parts.



Danger of poisoning.



Danger of an electric shock.



Danger of burns from touching hot parts.



Danger of damage to the pump or system.



Important note.

2. Understanding Pumps

2.1. Main Features

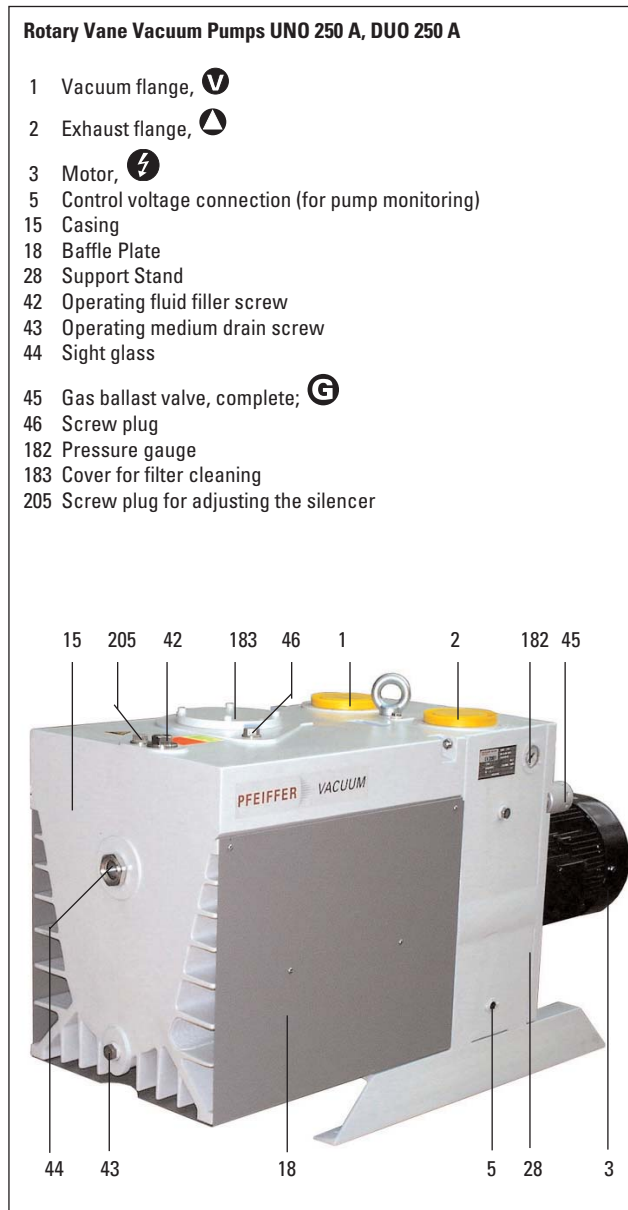

The UNO 250 A is a single stage and the DUO 250 A is a two stage rotary vane pump.

Special features:

- Pressurised oil lubrication
- Hydraulically controlled high vacuum safety valve
- Optional: Oil filter systems, Condensate separator, Operational monitoring systems.

Proper Use

- Rotary Vane Pumps UNO/DUO 250 A may only be used to generate vacuum.
- Do not use the pump as a compressor.
- Do not pump corrosive or explosive gases (a special version for these operations is available on request).
- Do not operate the pumps where explosive processes are involved. This is only permitted with the "explosive" version of the pump.
- Using accessories not named in this manual is not permitted without authorisation from Pfeiffer Vacuum.

Improper Use

The following are regarded as improper:

- Uses not covered above, and, in particular:
 - Connection to pumps and units which is not permitted according to their operating instructions.
 - Connection to units which contain touchable and voltage carrying parts.

Improper use will cause any rights regarding liability and guarantees to be forfeited

2.2. Differences Between The Pump Types

Type	Stage	Nominal flow rate at 50 Hz	Attainable Final Pressure (Total, without Gasballast)
UNO 250 A	one stage	267 m ³ /h	< 5.0 • 10 ⁻² mbar
DUO 250 A	two-stage	267 m ³ /h	< 3.0 • 10 ⁻³ mbar

Special Models

Helium tight model:

- Operating Fluid P3
- Leak rate < 1 • 10⁻⁵ mbar l/s
- Additional radial shaft seal (total of 3) with sealing oil chamber (oiler)
- Option: Special gas ballast valve for inert gas inlet (N₂) to prevent atmospheric air entering the system.

Korrosivgasausführung:

- Operating fluid F5
- Leak rate < 1 • 10⁻⁵ mbar l/s
- Additional radial shaft seal (total of 3) with sealing oil chamber (oiler)
- Vanes and sight glasses made from special materials.
- Option: Special gas ballast valve for inert gas inlet (N₂) to prevent atmospheric air entering the system.

3. Installation

3.1. Preparations For Installation



Do not carry out any unauthorised conversions or modifications on the pump.



Fill up with operating fluid before operating the first time (included in a separate pack in the delivery consignment). When transporting use only the eyebolts provided for the purpose.

3.2. Pump Assembly And Location

- ➔ Where stationary installation is involved, anchor the pump on site.
- ➔ Sight glass 44 on the front side must be visible and gas ballast valve  readily accessible.



When filled with operating fluid, do not tilt the pump otherwise operating fluid could escape via the exhaust opening.

- ➔ When installing the pump in a closed housing, ensure there is sufficient air circulation.

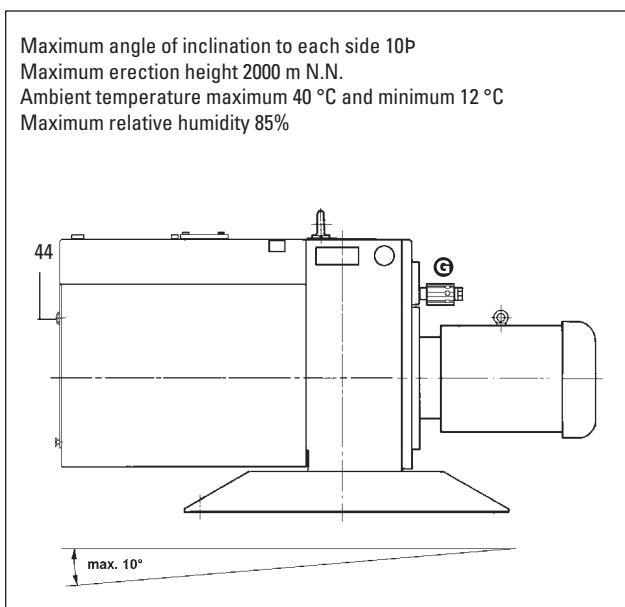

3.3. Connecting The Vacuum Side

- ➔ Keep the connection between the vacuum chamber and pump as short as possible.
- ➔ Remove all scaling and loose particles from welded lines prior to assembly.
- To protect the pump, separators, filters and cooling traps etc. (see Section 9. Accessories) can be fitted upstream of the pump. However, the conductance value of the accessory causes a reduction in volume flow rate.



Where rotary vane vacuum pumps are anchored, no forces from the piping system should be allowed to act on the pump. Suspend, decouple or support all piping concerned with the pump.

3.4. Connecting The Exhaust Side



Pressure can rise to dangerous levels in exhaust lines.

Lay exhaust lines without built-in shutoff devices. If a shut-off device is installed for internal operating reasons or if there is a risk of excess pressure developing in the lines, official accident prevention regulations must be complied with. The exhaust line diameter should not be less than 63 DN. The line from the pump must be laid with a downward gradient so that condensate is prevented from flowing back into the pump. Otherwise a trap must be installed.

Auspuffleitung nicht kleiner als DN 100 von der Pumpe aus fallend verlegen, damit kein Kondensat in die Pumpe zurückläuft. Andernfalls Abscheider einbauen. Der Auspuffdruck darf 1,5 bar nicht überschreiten.



Expelled gases and vapours can represent a hazard to health and/or the environment. For this reason the relevant regulations must always be complied with when working with toxic substances. Only officially approved filters may be used for the separation of such substances. This also applies when handling toxic or chemically unstable gases and to gases susceptible to polymerisation or to the formation of peroxide (see 9. Accessories).

3.5. Connecting To The Mains Power Supply



Power connections must comply with local regulations. Voltage and frequency information given on the rating plate must correspond to the mains voltage and frequency values. When the electrical connections have been completed, carry out the earthed conductor test.

The pump must be disconnected from the power before opening the terminal box. When switching on for the first time, check the direction of rotation:

Checking The Direction Of Rotation



Check the direction of rotation of the pump before filling up with operating medium.

- ➔ Remove blank flange on the exhaust flange,
 - do not take off sieve strainer from vacuum flange 1 and exhaust flange 2.
- ➔ Switch on pump for a short time (max. 3 seconds). Motor/motor fan must turn clockwise (see arrow P on motor fan cover).
- ➔ If direction of rotation is incorrect: Interchange two phases on the connecting cable.

Checking The Direction Of Rotation



Power section with motor to be protected

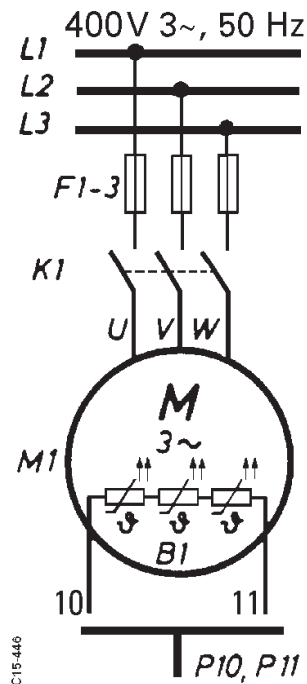

Three phase motors with PTC

Pumps fitted with these motors are used primarily in systems or in closed rooms. The motors of these pumps are fitted with three PTCs which are built into the stator windings. The connection of a tripping unit will protect the pump against overloading (see connection example).

Tripping unit:

PTC tripping unit with two switchover contacts at the output manufactured by Ziehl, type MSR 220 F (see Section 9, „Accessories“), AEG type TMA 4R or Siemens type 3 UN8 004.

Connection example for water cooled canned motors with Tripping unit (typ MSR 220 F, order no.: P 4768 051 FQ)

- U_S Control Voltage
- S1 Pressure key „OFF“
- S2 Pressure key „ON“
- S3 Control switch (reset key)
- K1 Motor contactor
- F1 ... F4 Fuses
- T1... T3 Temperature sensors
- H1 Signal lamp
- M Motor, 3-phase

¹⁾ Only for units with two relays outputs
²⁾ Only for type MSR
³⁾ Only for order no. P 4768 051 FQ

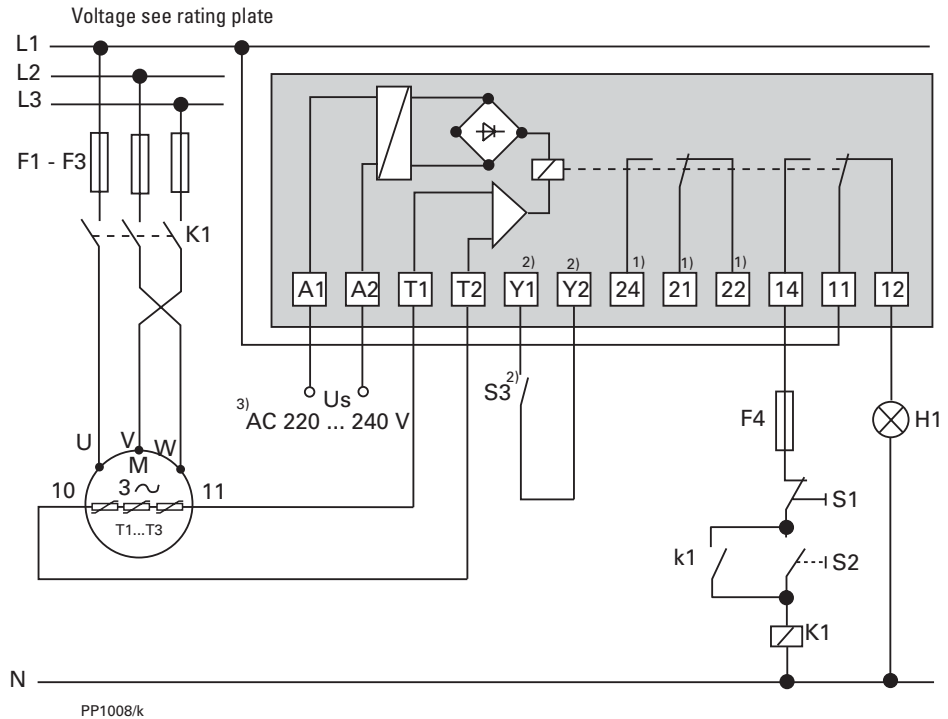

Tripping Units Type MSR save the switch-off occurring on thermal overload and it is necessary to manually reset via the integrated key or via the externally connected key S3 to switch back on. Switching on via the mains is automatically recognised as a reset.

The Three Phase Current Motor Circuit

The three phase motor winding consists of three identical coils.

Delta Connection

The three coils are connected in series with the connection point connected to the mains. The voltage of each coil is the same as the mains voltage whereas the mains current is the cube root of the coil current. Delta connections are denoted by the symbol Δ .

The voltage between the mains supply lines is called mains voltage. The mains current is the current which flows in the supply lines.

Star Connection

The ends of the three coils are connected at the star center. The terminal voltage is the cube root of the coil voltage; the mains and the coil current are the same. Star connections are denoted by the symbol Y .

A star connection three phase motor for 400 V mains voltage has a coil voltage of 230 V.

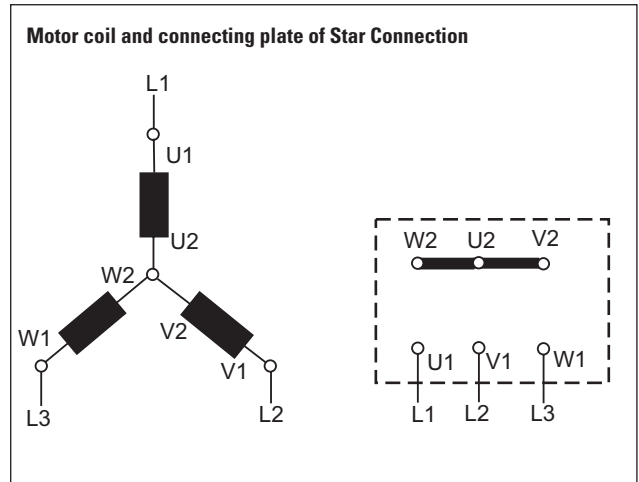
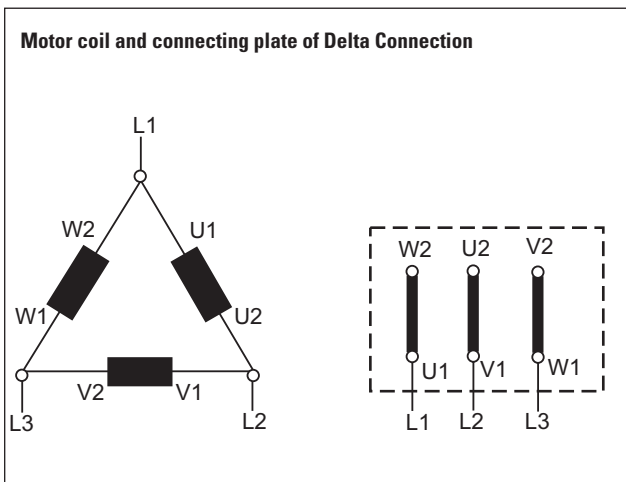



Important: The instructions in 4.1.2. must be observed when working with synthetic operating medium F5.

Helium tight and corrosive gas models UNO/DUO 250 A

- 45 Gas ballast valve
- 118 Radial shaft seal
- 122 Armature
- 126 O-ring
- 128 O-ring
- 132 Support washer
- 133 Radial shaft seal
- 134 Double supporting ring
- 135 Spacer
- 136 Oiler
- 138 O-ring
- 168 O-ring
- 169 Locking screw for connecting the gas ballast valve (when no valve is fitted)

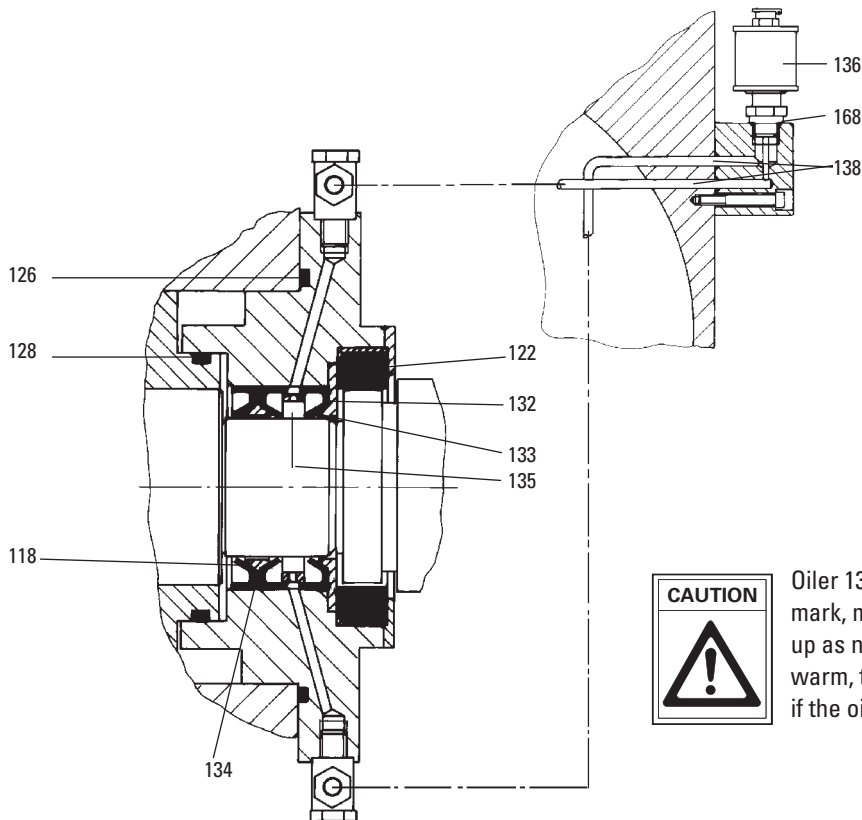

Oiler 136 should always be filled to the half way mark, maximum, (when the pump is cold); top up as necessary. When the pump becomes warm, the lubricant expands and can spill over if the oiler is too full.

3.6. Special Models

Helium Tight Models





- Helium tight models are distinguished by their high level tightness to the atmosphere.
- Helium tight models are operated, as standard, with operating medium P3.
- The rotor shaft is sealed with an additional radial shaft seal. The cavity between the radial shaft seals 133 is filled with operating medium and is supplied by the oiler 136.
- If the gas ballast valve 45 is not available, the opening should be closed with the locking screw 169 or a special gas ballast valve with dosing device and hose connection for flushing gas is available (on request).

Corrosive Gas Models

- Corrosive gas models are manufactured with special materials.
- The rotor shaft of both versions is sealed with an additional radial shaft seal. The cavity between the radial shaft seals 118 and 133 is filled with operating medium and is supplied by the oiler 136.
- If the gas ballast valve 45 is not available, the opening should be closed with the locking screw 169 or a special gas ballast valve with dosing device and hose connection for flushing gas is available (on request).
- Corrosive gas models are operated, as standard, with synthetic operating medium F5.

4. Operations

Rotary Vane Vacuum Pumps UNO/DUO 250 A

- 1 Vacuum flange, 
- 2 Exhaust flange, 
- 3 Motor, 
- 5 Socket for control voltage
- 15 Casing
- 28 Support stand
- 42 Operating fluid filler screw
- 43 Operating medium drain screw
- 44 Sight glass
- 45 Gas ballast valve, complete; 
- 182 Pressure gauge
- 183 Cover for filter cleaning

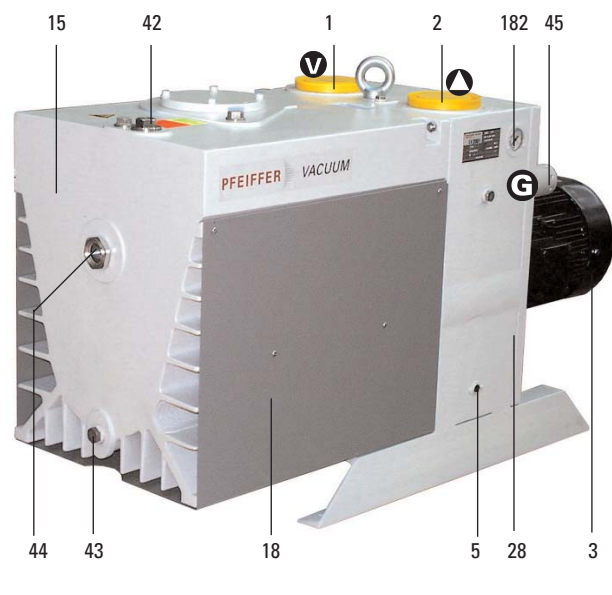

- ➔ Check operating fluid level only when the pump is warm and running and vacuum connection 1 and gas ballast valve  are closed.
- ➔ The level of operating fluid must always be between the top and the middle of the sight glass 44.
- ➔ Topping up operating fluid is possible when the pump is running and in final vacuum operations.
- ➔ In non-stop operations check operating fluid daily, otherwise whenever the pump is switched on.

Sight glass 44

Operating fluid level for the first filling and during operation

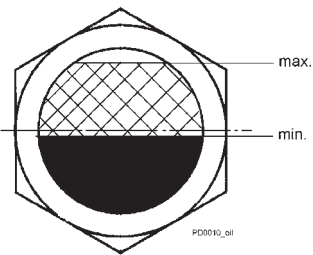

4.1.2. Operating Fluid F5

Only the synthetic operating fluid F5 may be used for corrosive gas model pumps. The use of other operating fluid must be cleared by the manufacturer.



When working with synthetic operating media, the manufacturer's directions must be observed.

If "F5" is heated above 250°C, toxic vapours which can harm the airways are given off.

Do not allow "F5" to come into contact with tobacco products (danger of poisoning when ignited). The precautions necessary in the handling of chemicals must be observed.

4.1. Filling Up And Checking The Operating Fluid



Standard version pumps are tested with operating fluid P3. Guarantees relating to attainment of final pressures and trouble free functioning apply only providing this operating fluid is used.

The delivery consignment contains sufficient operating fluid for one filling (valid only for P3).

Pumps for special applications (e.g. for pumping corrosive gases) can be operated with special operating fluids such as F5 and other Pfeiffer Vacuum operating fluids. The use of such operating fluids requires prior authorisation from the manufacturer.

P3 must be disposed of in accordance with local waste disposal regulations.

- ➔ Remove operating fluid filler screw 42.
- ➔ Fill up with operating fluid included in the consignment (only for P3); refer to rating plate for correct quantity.
- ➔ Replace operating fluid filler screw 42; be careful with the O-ring.



Operating fluids containing toxic or aggressive substances require special treatment. The instructions for handling such media must be observed.



Never fill into pumps which contain mineral oil residues.



If there is a noticeable loss of operating fluid, the radial shaft seals should be checked. If operating fluid is leaking out underneath the casing 15 from the opening between the support stand 28 and motor 3, the radial shaft seal must be replaced. Please contact your local Pfeiffer-Service (see Section 7.).

4.2. Switching The Pump ON And OFF



When operating the pump gets hot.

The pump can be switched ON and OFF in any pressure range. On switching off, the built-in high vacuum safety valve to the vacuum plant closes automatically and vents the pump. Minimum start-up temperature, in compliance with German Industrial Standard DIN 28 426: + 12 °C. On switching OFF (intake pressure < 750 mbar) the built-in high vacuum safety valve to the vacuum chamber closes automatically and the pump is vented.

When the pump is at operating temperature, the pressure gauge 182 indicates a operating fluid pressure between 0.8 and 2.5 bar. At a cold start (approx. 12°C), the pressure in the pressure gauge may rise up to max. 6 bar. When the pump temperature rises, the pressure drops to normal. With operating medium F5, the pressure of the pump at working temperature is set between 3 and 5 bar. When cold starting, pressure rises upto 15 bar.

In continuous operation the level of operating fluid must be checked daily at the sight glass 44 and the pressure at pressure gauge 182.

4.3. Operating The Pump With Gas Ballast

If condensable vapors are pumped off, the pump must always be operated with gas ballast. If the condensation exceeds the water vapor capacity of the pump, a condenser should be connected upstream. If no condenser is connected, the condensate produced due to the difference in temperature between the pump housing and pump body must be drained at drain plug 43. The condensate produced inside the pump can be observed at sight glass 44 as a rising operating fluid level.

4.3.1. Standard Model

Gas ballast valve 45 is fitted with a sliding sleeve which, when pushed towards the pump, opens the valve and when pushed away from the pump, shuts the valve. Intermediate settings are not possible.

Gas ballast valve standard model

- 28 Support stand
- 45 Gas ballast valve with sliding sleeve
- 182 Pressure gauge

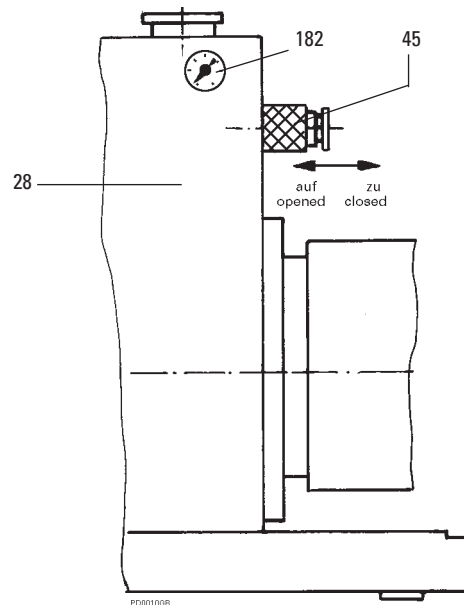

4.3.2 Corrosive Gas Model

Gas ballast valve 45 is fitted with a dosing device and a flushing gas connection. It has a sliding sleeve which opens the valve when pushed towards the pump and shuts the valve when pushed away from the pump. The dosing device is closed when the groove in the dosing screw is in the horizontal position; in the vertical position the dosing device is fully open. A flow meter enables any intermediate gas volume setting between fully open and fully closed to be made.



Flushing gas must be connected when operating corrosive gas version pumps. The gas ballast valve must be open. Flushing gas pressure may not exceed 1.5 bar. Our specialists would be pleased to give advice regarding the type and volume of flushing gas required.

Gasballast valve helium tight and corrosive gas models

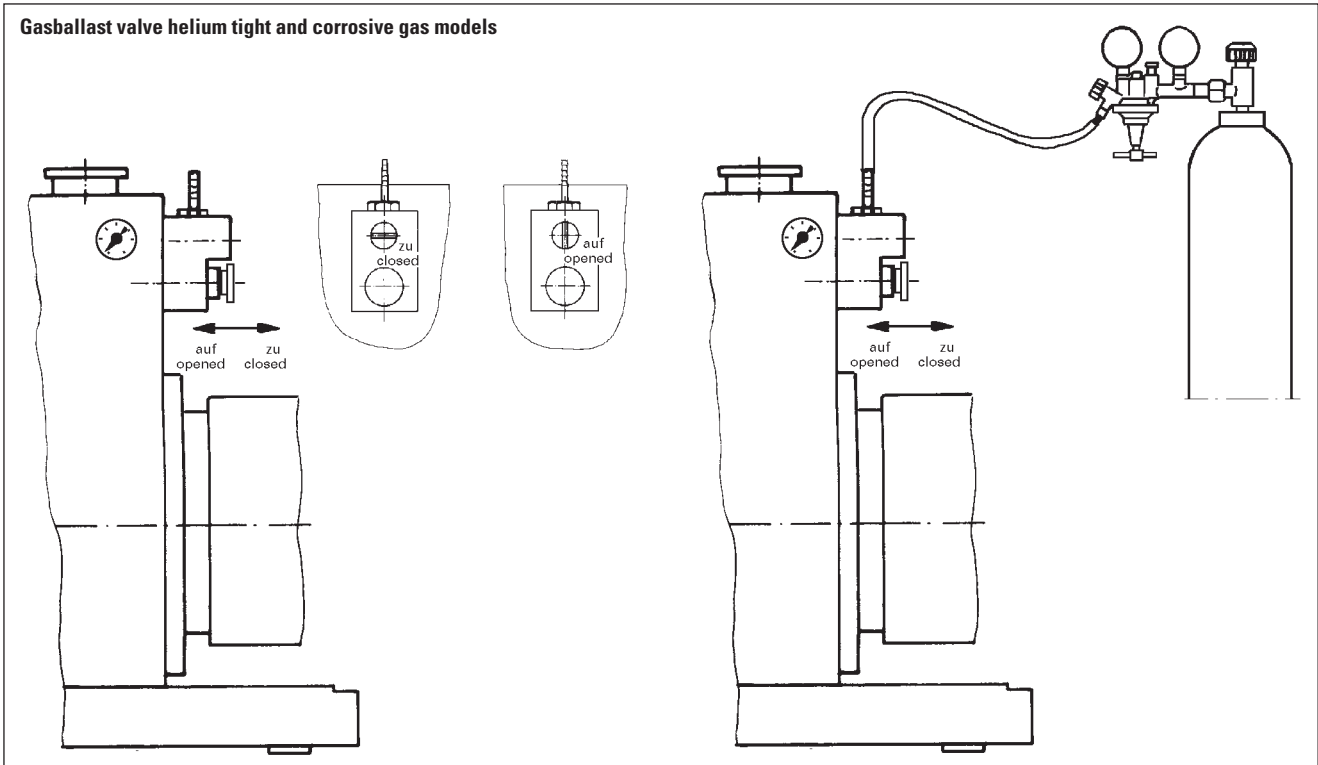

4.4. Pumping Off Dry Gases

No special measures are necessary. The gas ballast valve may remain closed.

4.5. Pumping Off Vapours



To prevent their condensation in the pump, vapours should only be pumped off with the pump at operating temperature and the gas ballast valve 45 open. Observe pump water vapour tolerance levels (see Section 8.0 Technical Data). When the process has been completed, allow the pump to continue running for approx. 30 minutes for operating medium cleaning purposes.

5. What To Do In Case Of Breakdown?

Problem	Possible Causes	Remedy
Pump doesn't attain final pressure	Pump dirty Operating fluid dirty Leak in system	Operate pump for a longer period with open gasballast valve or change operating fluid Repair leak
Unusual operating noises	Damaged pump stages Damaged coupling piece	Request repair by Pfeiffer Vacuum Service Request repair by Pfeiffer Vacuum Service
Oil leaking from the foot of the pump	Radial shaft seal defective	Request repair by Pfeiffer Vacuum Service
Pump doesn't start	Ambient temperature < 12 °C Dirty pump stages Damaged pump stages	Warm up pump Request cleaning by Pfeiffer Vacuum Service Request repair by Pfeiffer Vacuum Service
Further repairs can only be carried out by trained specialists in accordance with Service Instructions.		

6. Maintenance

When carrying out servicing work, take the following precautions:



Always ensure the pump cannot be switched on when carrying out any work on the pump. If necessary, remove the pump from the system to carry out inspection work.

- ➔ Only dismantle the pump as far as is necessary in order to repair defects.
- ➔ Dispose of used operating fluid in compliance with local regulations.
- ➔ When working with synthetic operating media, toxic substances and substances contaminated with corrosive gases, the relevant instructions governing their use must be observed.
- ➔ Only use benzene or similar agents for cleaning pump parts. Do not use soluble cleaning agents.

6.1. Changing The Operating Fluid

The rate of deterioration of the operating fluid depends on the pump applications.

- ➔ The level of deterioration of organic operating fluids (for example P3) can be read off from the colour scale in accordance with DIN 51578 on the supplementary sheet PK 800 219 BN/B, on request.
 - The colour scale enables precise colour determination.
- ➔ Fill a specimen in a test tube or some similar vessel and test by holding against the light.
- ➔ Where the discolouration is dark yellow to red brown (equivalent to 4 ... 5 on the scale) change operating fluid.



Where organic operating fluids, for example P3, are involved, the operating fluid should be changed every 8000 h; at least once a year!

Replacing The Operating Fluid

- ➔ Switch off the pump.
- ➔ Unscrew operating fluid drain screw 43 and drain operating fluid.



The operating fluid temperature can be as high as 80 °C. During maintenance and repair work, process related toxic gases and vapours can escape from the operating fluid which may become contaminated with harmful substances (radioactive, chemical etc.).

Disposal of used operating fluid is subject to the relevant regulations.

- ➔ Screw in operating fluid drain screw 43.
- ➔ Allow pump to run for about 10 seconds with open vacuum flange.

- ➔ Drain off remaining operating fluid.
- ➔ In the case of serious contamination, the operating fluid will have to be changed several times.
- ➔ Screw in operating fluid drain screw 43 with O-ring.

6.2. Cleaning The Oil Filter



Also clean the oil filter 181 every time you change the pump fluid.

- ➔ Unscrew screws 184 and remove the cover 183, take care with the o-ring.
- ➔ Unscrew screws 185 and lift the oil filter 181 out of the pump on flange 186.
- ➔ Dismantle the oil filter as shown below and clean the star-shaped filtering sieve 187 in benzene (naphtha) or similar cleaning agent.
- ➔ Reassemble in reverse order.

Filling in operating fluid

- ➔ Check the drain plug 43 for tight seat.
- ➔ Remove operating fluid filler screw 42.
- ➔ Fill up the new operating fluid; refer to rating plate for correct quantity (UNO 250 A --> 30 l, DUO 250 A --> 23 l).
- ➔ Replace operating fluid filler screw 42; be careful with the O-ring.
- ➔ Check operating fluid level at the sight glass as per section 4.1..



Operating fluid can contain substances from the medium pumped. Operating fluid must be disposed of in accordance with the local respective regulations.

Please request safety instruction data sheets for operating fluids from Pfeiffer Vacuum.

Dismantling and cleaning the oil filter

- | | |
|---|---|
| 1 Vacuum flange,  | 185 Screw |
| 2 Exhaust flange,  | 186 Flange |
| 42 Operating fluid filler screw | 187 Star-shaped filtering sieve |
| 43 Operating fluid drain screw | 188 Spacer sleeve |
| 44 Sight glass | 189 Washer |
| 45 Gas ballast valve, complete;  | 190 Screw |
| 181 Ölfilter, komplett | 191 O-ring |
| 183 Cover for filter cleaning | 205 Screw plug for adjusting the silencer |
| 184 Screw (4 pieces) | |

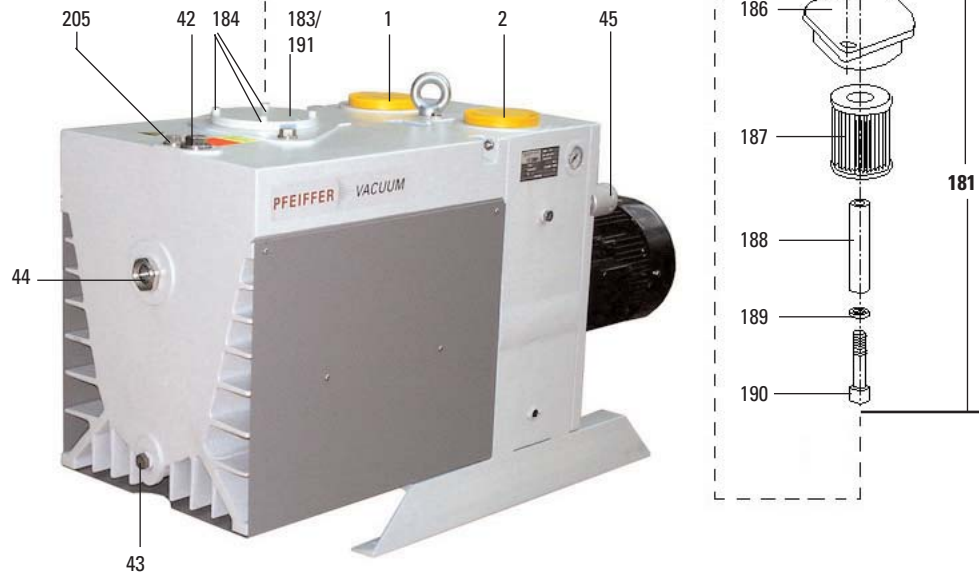

6.3. Re-Setting The Silencer

If the silencer 13 is not functioning, a knocking noise becomes audible at end vacuum. This does not cause damage to the pump but it may be disturbing in quiet rooms. Setting can be carried out while the pump is running and the intake socket and gas ballast valve are closed, using a normal screwdriver:

- ➔ The pump must have reached its operating temperature.
- ➔ Remove locking screw 46 (UNO 120A) or operating fluid filler screw 42 (DUO 250 A).
- ➔ Using a screwdriver, open the valve spindle 47 approx. 3 turns (flushing) for some seconds and then close it again completely (clockwise).
- ➔ Slowly open the valve spindle 47 (1/2 to a complete turn) until the knocking noise is no longer audible.
- ➔ Replace locking screw 46 or operating fluid filler screw 42 paying attention to the O-ring.

Adjusting the silencer

- | | |
|----|--|
| 42 | Screw plug of the silencer (DUO 250 A) |
| 46 | Screw plug of the silencer (UNO 250 A) |

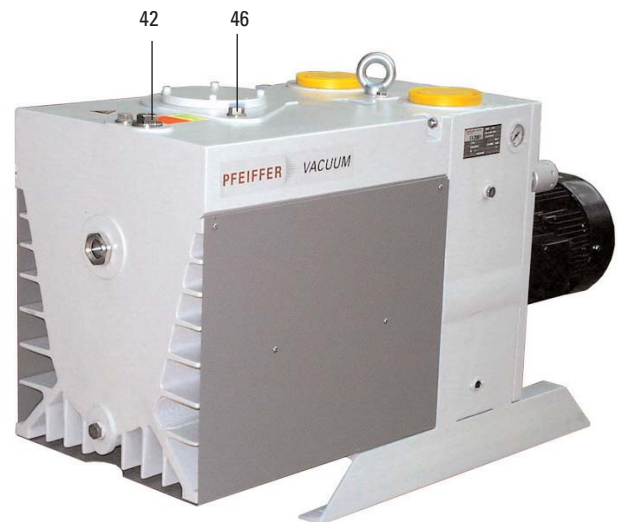

6.4. Cleaning The Gas Ballast Valve

Gas ballast valve 45 can only get dirty if the ambient air sucked in is dusty.

Dismantling and assembling the Standard Model

- ➔ Unscrew valve housing 68 at hexagon nut, take care with the O-ring 31; if necessary proceed as follows:
 - Remove circlip 59 and pull off sleeve 61, insert round steel bar into boring and unscrew valve housing 68 taking care with the O-ring 31.
- ➔ Clean all parts.
- ➔ Check both o-rings 60 for wear and replace if necessary.
- ➔ Lightly lubricate o-rings with operating fluid.
- ➔ Re-assemble the parts in reverse order.

Dismantling and assembling the Helium Tight and Corrosive Gas Models

- ➔ Unscrew valve housing 68 at hexagon nut, take care with the O-ring 31; if necessary proceed as follows:
 - Remove circlip 59 and pull off sleeve 61, insert round steel bar into boring and remove valve housing 68 taking care with the O-ring 31.
- ➔ Remove circlip 67 and dosing insert 66 from dosing valve body 64.
- ➔ Clean all parts.
- ➔ Check O-rings 65 and 69 for wear and replace if necessary.
- ➔ Lightly oil O-rings with operating fluid.
- ➔ Re-assemble the parts in reverse order.

6.5. Cleaning The Silencer

Dismantling and assembling

- ➔ Remove the silencer 47 ... 50 and 129 in axial direction and clean it.
- ➔ Check o-rings 48 and 49, valve spindle 47 and valve seat in 13 for wear, replace if necessary.
- ➔ Reassemble in reverse order.
Carefully push o-ring 48 into the groove in part 47 and lightly lubricate with operating fluid. The o-ring 49 must be fitted around part 129.

Gas ballast devices and silencer

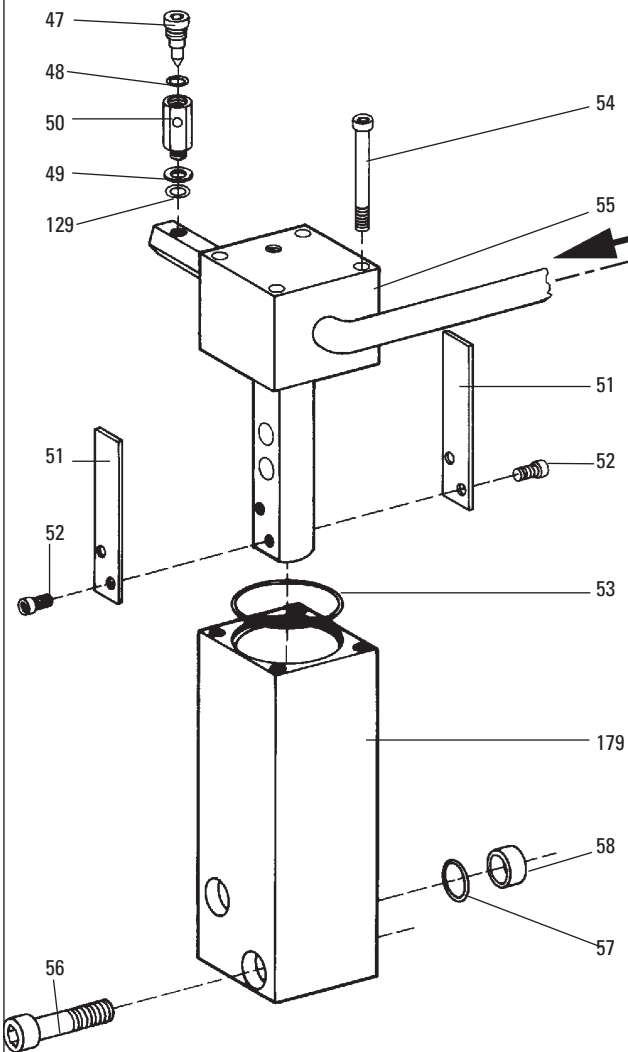

Gas ballast inlet valve 45 for standard models

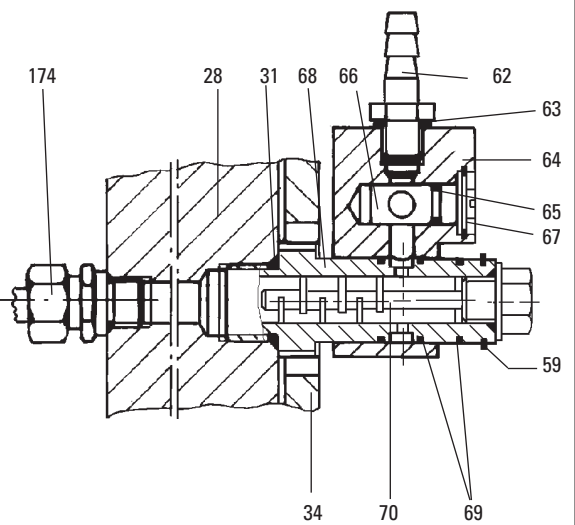
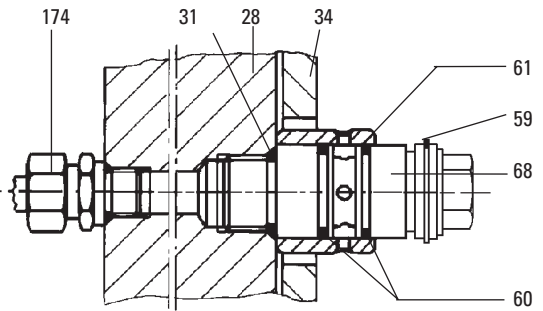

Gas ballast inlet valve 45 for helium-tight and corrosive gas models

- 13 Silencer
- 14 Non-return valve
- 28 Support stand
- 31 O-ring
- 34 Cover
- 47 Valve spindle
- 48 O-ring
- 49 O-ring
- 50 Valve housing
- 51 Plate spring
- 52 Screw

- 53 O-ring
- 54 Screw
- 55 Insert
- 56 Screw
- 57 O-ring
- 58 Centering sleeve
- 59 Circlip
- 60 O-ring
- 61 Sleeve
- 62 Flushing gas connection
- 63 O-ring
- 64 Dosing valve unit

- 65 O-ring
- 66 Dosing insert
- 67 Circlip
- 68 Valve housing
- 69 O-ring
- 70 Rohr
- 129 Centering ring
- 174 Screw connection
- 179 Housing non-return valve

6.6. Shutting Down For Longer Periods

Should the pump have to be shut down for an longer period, the complete pumping system must be adequately protected against corrosion.

- ➔ Switch off pump.
- ➔ Unscrew operating fluid drain screw 43 and drain operating fluid as per Section 6.1.
- ➔ Screw in operating fluid drain screw 43; keep an eye on the position of the O-ring.
- ➔ Allow pump to run for about 10 seconds with open vacuum flange. .
- ➔ Drain off remaining operating fluid.
- ➔ Fill up pump with fresh operating fluid:
Filling: UNO 250 A --> 21 l
DUO 250 A --> 18 l

If this amount of operating fluid is filled in, the level is extremely high but this is necessary to protect all parts of the pump against corrosion.



Before operating, the operating fluid must be reduced to its normal level.

7. Service

Do Make Use Of Our Service Facilities

In the event that repairs are necessary to your pumping station, a number of options are available to you to ensure any system down time is kept to a minimum:

- Have the pump repaired on the spot by our Pfeiffer Vacuum Service Engineers;
- Return the individual components to the manufacturer for repairs;
- Replace individual components with a new value exchange units.

Local Pfeiffer Vacuum representatives can provide full details.

Before Returning:

- ➔ When returning the pump please use original factory packing.
- ➔ Dismantle all accessories.
- ➔ Drain operating fluid.
- ➔ If the pump is free of harmful substances, please attach a clearly visible notice: "Free of contamination" (to the unit being returned, the delivery note and accompanying paperwork).

Harmful substances" are substances and preparations as defined in current legislation. Pfeiffer Vacuum will carry out the decontamination and invoice this work to you if you have not attached this note. This also applies where the operator does not have the facilities to carry out the decontamination work. Units which are contaminated microbiologically, explosively or radioactively cannot be accepted as a matter of principle.

Fill Out The Contamination Declaration

- ➔ In every case the "Contamination Declaration" must be completed diligently and truthfully.
- ➔ A copy of the completed declaration must accompany the unit; any additional copies must be sent to your local Pfeiffer Vacuum Service Center.

Please get in touch with your local Pfeiffer Vacuum representatives if there are any questions regarding contamination.



Decontaminate units before returning or possible disposal. Do not return any units which are microbiologically, explosively or radioactively contaminated.

Returning Contaminated Units

If contaminated units have to be returned for maintenance/repair, the following instructions concerning shipping must be followed without fail:

- ➔ Neutralise the pump by flushing with nitrogen or dry air.
- ➔ Seal all openings to the air.
- ➔ Seal pump or unit in suitable protective foil.
- ➔ Ship units only in appropriate transport containers.



Repair orders are carried out according to our general conditions of sale and supply.

- ➔ If repairs are necessary, please send the unit together with a short damage description to your nearest Pfeiffer Vacuum Service Center.

8. Technical Data

Single stage Two stage	Unit	UNO 250 A	DUO 250 A
Connection nominal diameter Inlet Outlet	ISO-F ISO-F	DN 100 DN 100	DN 100 DN 100
Rated volume flow rate at 50 Hz 60 Hz	m ³ /h m ³ /h	267 320	267 320
Volume flow rate 50 Hz 60 Hz	m ³ /h m ³ /h	250 300	250 300
Final pressure total without gas ballast total with gas ballast	mbar mbar	$< 5.0 \cdot 10^{-2}$ < 1	$< 3.0 \cdot 10^{-3}$ $< 6.0 \cdot 10^{-3}$
Auspuffdruck min Auspuffdruck max	mbar mbar	> 250 < 1500	> 250 < 1500
Water vapour compatibility 50 Hz 60 Hz	mbar mbar	33 33	25 25
Water vapour acceptable capacity 50 Hz 60 Hz	g/h g/h	5820 6980	4530 5440
Noise development without gas ballast	dB(A)	62	62
Operating fluid, amount Max. admissible operating temperature ¹⁾	l °C	30 90	23 90
Nominal rotation speed of pump at 50 Hz at 60 Hz	1/min 1/min	975 1175	975 1175
Nominal motor power for three phase motor with temperature sensor at 50 Hz at 60 Hz	kW kW	7,5 7,5	7,5 7,5
Weight pump with three-phase motor.	kg	375	410
¹⁾ The maximum admissible operating temperature of 90 °C is valid for an ambient temperature of 25 °C and operating fluid P3, without gas ballast. Operating temperatures in the range of 110 ... 115 °C could be caused by increased ambient temperature to max. 40 °C (for operating fluid P3).			

8.1. Dimensions

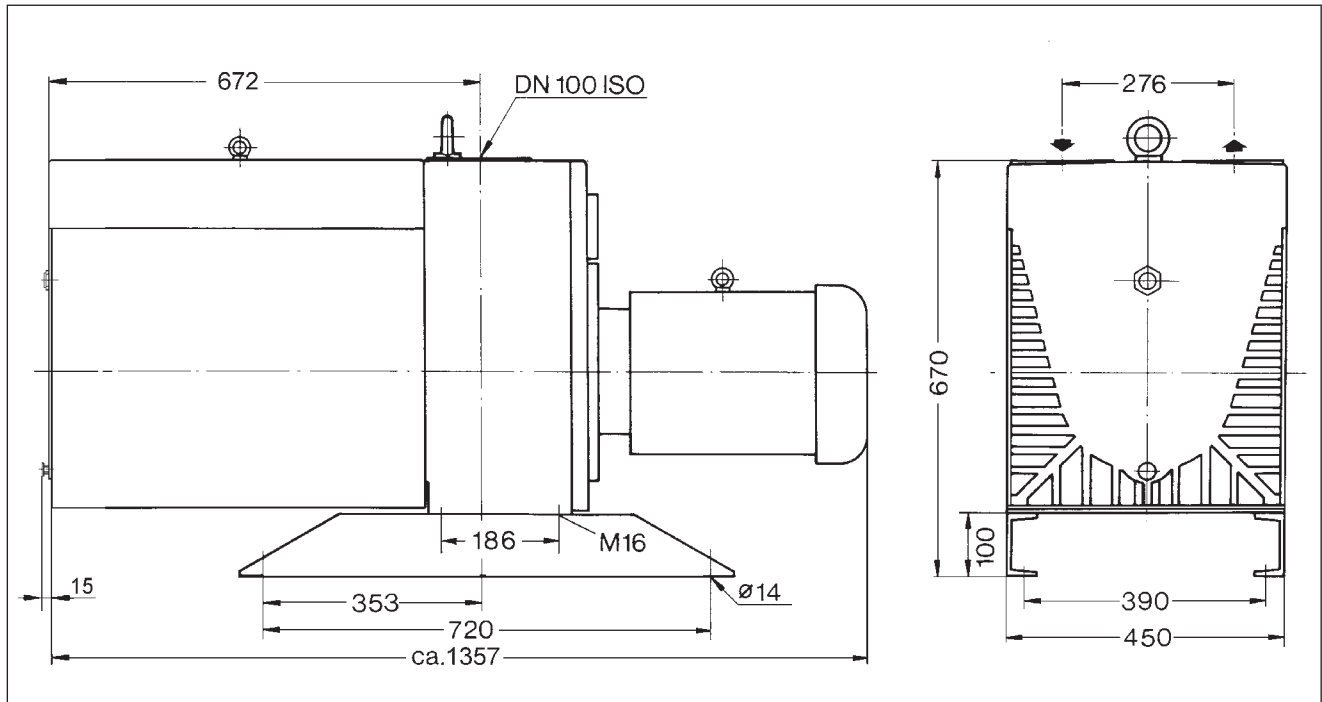

9. Accessories

A comprehensive range of accessories can be found in the Pfeiffer Vacuum catalogue, to:

- extend the application range of the pumps and
- protect the pump from wear, when used under extreme operating conditions.

The tripping device to protect against overloading the pump can be ordered under the order number P 4768 051 FQ.

10. Spare parts

Pos.	Description	Quantity	Size	Number	Comment	Order Quantity
	Set of seals, Standard-version	1		PK 216 099-T		
	Set of seals, C- und H-version	1		PK 216 199-T		
1	Sight glass, standard-version	1	R 15"	PK 213 140		
1	Sight glass, C- and H-version	1	R 15"	PK 214 131 AX		
2	Gas ballast valve, standard-version	1		PK 216 136 -U		
2	Gas ballast valve, C- and H-version	1		PK 216 142 -U		
5	Socket with PCB	1		PK 215 306 -X		
29	Sieve insert	2	DN 100 ISO	PK 300 044 -X		
	Tripping unit			P 4768 051 FQ		

When ordering accessories and spare parts please be sure to state the full part number. When ordering spare parts please state additionally the unit type and unit number (see rating plate). Please use this list as an order form (by taking a copy).

Declaration of Contamination of Vacuum Equipment and Components

The repair and/or service of vacuum components will only be carried out if a correctly completed declaration has been submitted. Non-completion will result in delay.

The manufacturer could refuse to accept any equipment without a declaration.

This declaration can only be completed and signed by authorised and qualified staff:

1. Description of component:

- Equipment type/model: _____
- Code No.: _____
- Serial No.: _____
- Invoice No.: _____
- Delivery Date: _____

2. Reason for return:

3. Equipment condition

- Has the equipment been used?
yes no
- What type of pump oil was used?

- Is the equipment free from potentially harmful substances?
yes (go to section 5)
no (go to section 4)

4. Process related contamination of equipment

- toxic yes no
- corrosive yes no
- microbiological hazard*) yes no
- explosive*) yes no
- radioactive*) yes no
- other harmful substances yes no

*) We will not accept delivery of any equipment that has been radioactively or microbiologically contaminated without written evidence of decontamination!

Please list all substances, gases and by-products which may have come into contact with the equipment:

Tradename Product name Manufacturer	Chemical name (or Symbol)	Danger class	Precautions associated with substance	Action if spillage or human contact
1.				
2.				
3.				
4.				
5.				

5. Legally Binding Declaration

I hereby declare that the information supplied on this form is complete and accurate. The despatch of equipment will be in accordance with the appropriate regulations covering Packaging, Transportation and Labelling of Dangerous Substances.

Name of Organisation: _____

Address: _____ Post code: _____

Tel.: _____

Fax: _____ Telex: _____

Name: _____

Job title: _____

Date: _____ Company stamp: _____

Legally binding signature: _____



Konformitätserklärung
Declaration of Conformity



im Sinne folgender EU-Richtlinien:
pursuant to the following EU directives:

- **Maschinen/Machinery 98/37/EG (Anhang/Annex IIA)**
- **Elektromagnetische Verträglichkeit/Electromagnetic Compatibility 89/336/EWG**
- **Niederspannung/Low Voltage 73/23/EWG**

Hiermit erklären wir, daß das unten aufgeführte Produkt den Bestimmungen der EU-Maschinenrichtlinie 98/37/EG, der EU-Richtlinie über Elektromagnetische Verträglichkeit 89/336/EWG und der EU-Niederspannungsrichtlinie 73/23/EWG entspricht.

We hereby certify, that the product specified below is in accordance with the provision of EU Machinery Directive 98/37/EEC, EU Electromagnetic Compatibility Directive 89/336/EEC and EU Low Voltage Directive 73/23/EEC.

Produkt/Product:

UNO/DUO 250 A

Angewendete Richtlinien, harmonisierte Normen und angewendete nationale Normen:

Guidelines, harmonised standards, national standards which have been applied:

DIN EN ISO 12100-1; DIN EN ISO 12100-2;
60335-1, -41; EN 61 010-1
EN 294; EN 60 204
EN 50 081-1; EN 1012-2
EN 50 082-2

Unterschrift/Signature:



Pfeiffer Vacuum GmbH
Berliner Str. 43
35614 Asslar
Germany

(W. Dondorf)
Geschäftsführer
Managing Director

Vacuum is nothing, but everything to us!



Turbo Pumps



Rotary Vane Vacuum Pumps



Roots Pumps



Dry Vacuum Pumps



Leak Test Units



Valves



Flanges, Feedthroughs



Vacuum Measurement



Gas Analysis



System Technology



Service

PFEIFFER  **VACUUM**

Pfeiffer Vacuum Technology AG · Headquarters/Germany

Tel. +49-(0) 64 41-8 02-0 · Fax +49-(0) 64 41-8 02-2 02 · info@pfeiffer-vacuum.de · www.pfeiffer-vacuum.net