

# Instruction Manual

## IPX Dry Vacuum Pumps

<i>Description</i>	<i>Electrical Supply</i>	<i>Item Number</i>
<i>IPX100 Dry Vacuum Pump</i>	<i>200/208 V, 50/60 Hz</i>	<i>A409-02-977</i>
<i>IPX100 Dry Vacuum Pump</i>	<i>400 V, 50/60 Hz</i>	<i>A409-02-973</i>
<i>IPX100A Dry Vacuum Pump</i>	<i>200/208 V, 50/60 Hz</i>	<i>A409-04-977</i>
<i>IPX100A Dry Vacuum Pump</i>	<i>400 V, 50/60 Hz</i>	<i>A409-04-973</i>
<i>IPX180A Dry Vacuum Pump</i>	<i>200/208 V, 50/60 Hz</i>	<i>A409-24-977</i>
<i>IPX180A Dry Vacuum Pump</i>	<i>400 V, 50/60 Hz</i>	<i>A409-24-973</i>
<i>IPX500A Dry Vacuum Pump</i>	<i>200/208 V, 50/60 Hz</i>	<i>A409-14-977</i>
<i>IPX500A Dry Vacuum Pump</i>	<i>400 V, 50/60 Hz</i>	<i>A409-14-973</i>



Replace this page with DofC

# CONTENTS

Section	Title	Page
1	INTRODUCTION	1
1.1	Scope and definitions	1
1.2	Description	1
1.3	Pump protection sensors	2
1.4	LEDs	3
1.5	Connections	3
1.6	Control and monitoring	3
1.7	IPX pump labels	3
2	TECHNICAL DATA	9
2.1	General	9
2.2	Performance	9
2.3	Electrical data	10
2.4	Cooling-water supply	10
2.5	Materials in contact with process gases	11
3	INSTALLATION	15
3.1	Safety	15
3.2	Unpack and inspect	15
3.3	Locate the IPX pump	15
3.4	Connect the inlet to your process system	16
3.5	Connect the inlet to your process system (extra notes for IPX180A and IPX500A)	16
3.6	Connect the outlet to your exhaust extraction system	17
3.7	Leak test the system	17
3.8	Connect the cooling-water supply	18
3.9	Connect the cooling-water (extra notes for IPX A pumps)	18
3.10	Connect to your emergency stop circuit	19
3.11	Connect the IPX pump to the electrical supply	19
3.12	Connect to your control equipment	20
4	OPERATION	23
4.1	Start-up	23
4.2	Manual shut-down	23
4.3	Idle mode	23
4.4	Status and fault indications	23
4.5	Oil sightglass	24
4.6	Automatic shut-down	24
4.7	Water filter inspection	24
4.8	Restart after automatic shut- down	25
4.9	Removing the pump from the vacuum system	25

## CONTENTS (continued)

Section	Title	Page
5	MAINTENANCE	27
5.1	Safety	27
5.2	Maintenance plan	27
5.3	Inspect the pipelines and connections	28
5.4	Cleaning the pump	28
5.5	Service the IPX pump	28
5.6	Fault finding	29
6	STORAGE AND DISPOSAL	31
6.1	Storage	31
6.2	Disposal	31
7	SERVICE, SPARES AND ACCESSORIES	33
7.1	Introduction	33
7.2	Service	33
	INDEX	35
	RETURN OF BOC EDWARDS EQUIPMENT	

## ILLUSTRATIONS

Figure	Title	Page
1	Recommended applications	2
2	The IPX pump	4
3	The IPX A variant	5
4	Labels on the IPX pump	6
5	Labels on the IPX A pump	7
6	Speed curve (mbar-cmh)	12
7	Speed curve (Torr - cfm)	12
8	IPX installation dimensions	13
9	IPX A installation dimensions	14
10	Water-out port	19
11	Schematic diagram of emergency stop facility	20
12	Remove the filter inlet fitting	24
13	Remove the filter	24
14	Flush the filter	24
15	Refit the filter	25
16	Refit the filter inlet fitting	25

## TABLES

Table	Title	Page
1	LEDs	3
2	Connections	3
3	Control and monitoring	3
4	Pump labelling information	8
5	General	9
6	Performance	9
7	Electrical data	10
8	Cooling water supply	10
9	Materials in contact with process gases	11
10	Interface connector signals	21
11	Maintenance plan	28
12	Fault finding	29
13	Accessory kits	33

This page intentionally blank.

# 1 INTRODUCTION

## 1.1 Scope and definitions

This manual provides installation, operation and maintenance instructions for the BOC Edwards IPX range of Dry Vacuum pumps (these are abbreviated to 'IPX pump' for the remainder of this manual). Where relevant, specific references are made to individual pump types. You must use the IPX pump as specified in this manual.

Read this manual before you install, operate and maintain the IPX pump. Important safety information is highlighted as **WARNING** and **CAUTION** instructions; you must obey these instructions. The use of **WARNINGS** and **CAUTIONS** is defined below.

	<b>WARNING</b> Warnings are given where failure to observe the instruction could result in injury or death to people.
--	--

<b>CAUTION</b> Cautions are given where failure to observe the instruction could result in damage to the equipment, associated equipment and process.
--

Throughout this manual, page, figure and table numbers are sequential.

The units used throughout this manual conform to the SI international system of units of measurement; US equivalent units of measurement are also given.

The following IEC warning labels appear on the pump:



Warning - refer to accompanying documentation.



Warning - risk of electric shock.



Warning - hot surfaces.

## 1.2 Description

	<b>WARNING</b> BOC Edwards take no responsibility for damage or injury caused by improper use of the equipment.
--	--

The IPX pump is designed for clean duty chambers using air, nitrogen or inert gases. Refer to Figure 1 for recommended applications. Please note that inappropriate use of the IPX pump may invalidate the warranty. If in doubt about the suitability of IPX for an application not shown in Figure 1, please contact BOC Edwards.

The pump operates at pressures between atmospheric and ultimate vacuum, with no lubricating or sealing fluid in the pumping chamber. This ensures a clean pumping system without back-migration of oil or fluid into the system evacuated.

**IPX Dry Vacuum Pumps**

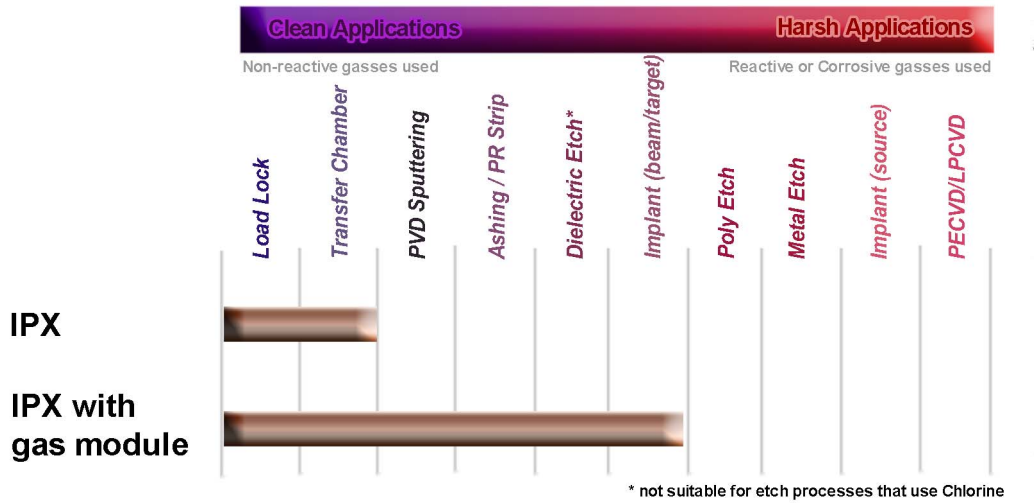

Figure 1 - Recommended applications

The stator of the pump and the enclosed motor are water-cooled; the IPX pump is therefore suitable for applications in clean environments where fan cooling is unacceptable. Cooling water must be provided commensurate with environmental conditions (humidity and temperature) such that the dewpoint is not reached. It is anticipated that in typical cleanroom conditions the ambient temperature and humidity will be such that cooling water in the temperature range 15 to 35°C should not cause operational problems. If in doubt about operating conditions please contact BOC Edwards.

Refer to Figures 2 and 3. The pump has an electrical supply (EMC) filter (5) and an inverter drive (10), which provides the electrical supply to the pump-motor. LEDs on the inverter drive identify the status of the IPX pump: see Section 1.4. Motor speed depends on the pressure at the pump inlet. When you first start up the pump with the inlet pressure at or close to atmospheric pressure, the motor accelerates to a speed which is limited by the power which can be supplied by the inverter drive. As the pressure at the inlet is reduced, the motor speed increases, until it eventually reaches its preset maximum speed. If the pressure at the inlet increases, the motor will slow down again.

The IPX pump is supported by four vibration isolators (6).

Pump protection sensors automatically shut down the pump when a fault condition arises: refer to Section 1.3.

**1.3 Pump protection sensors**

The IPX pump has two pump protection sensors, as follows:

- A thermal snap-switch monitors the temperature of the body of the IPX pump. In the event that the body temperature exceeds the preset limits, the snap switch will operate to switch off the electrical supply to the pump-motor and provide an alarm status output.
- A thermistor is connected to the pump-motor; the electrical resistance of the thermistor corresponds to the temperature of the windings in the pump-motor. In the event that the motor temperature exceeds the preset limits, the thermistor resistance is used to switch off the electrical supply to the pump-motor and provide an alarm status output.

When the IPX pump is automatically shut down by a pump protection sensor, the Alarm LED goes on (see Section 1.4).



## IPX Dry Vacuum Pumps

*Note: When a pump protection sensor operates, only the electrical supply to the pump-motor is switched off; the IPX is not isolated from the electrical supply.*

### 1.4 LEDs

Refer to Table 1, Figures 2 and 3.

### 1.5 Connections

Refer to Table 2, Figures 2 and 3.

### 1.6 Control and monitoring

The IPX pump cannot be manually operated; it must be controlled and monitored by your own control equipment, which you must connect to the IPX pump through the interface connector (Figures 2 and 3, item 12). The signals on the interface connector are of two types: control inputs and status outputs. (Table 3).

Refer to Section 3.12 for full definitions of the signals on the interface connector.

### 1.7 IPX pump labels

Refer to Table 4, Figures 4 and 5.

LEDs	Reference data
Power LED (14)	This green LED is on whenever the external electrical supply to the IPX pump is switched on.
Run LED (15)	This green LED is on when the IPX pump has started and is operating.
Idle LED (16)	This green LED is on when the pump is in idle mode.
Alarm LED (17)	This red LED goes on when the IPX pump has been automatically shut down because a pump protection sensor operated (see Section 1.3), or because the inverter drive has failed.

Table 1 - LEDs

Connection items	Reference data
Cooling-water inlet and outlet (8, 2)	Use these to connect your cooling-water supply and return pipelines to the IPX pump: refer to Section 3.8.
Electrical supply cable (4)	Use this to connect your external electrical supply to the IPX pump: refer to Section 3.11.
Interface connector (12)	Use this to connect your control equipment to the IPX pump, to allow you to control the operation of the pump: refer to Section 3.12.
Earth (ground) stud (19)	Use this to earth (ground) the IPX pump: refer to Section 3.11.

Table 2 - Connections

Control items	Reference data
Control input	Use your control equipment to set or reset the pump start/stop control input signal to start and stop the IPX pump.
Status outputs	Your control equipment can monitor the Pump Running, Pump Warning and Pump Alarm status outputs; these outputs identify the status of the IPX pump.

Table 3 - Control and monitoring

**IPX Dry Vacuum Pumps**

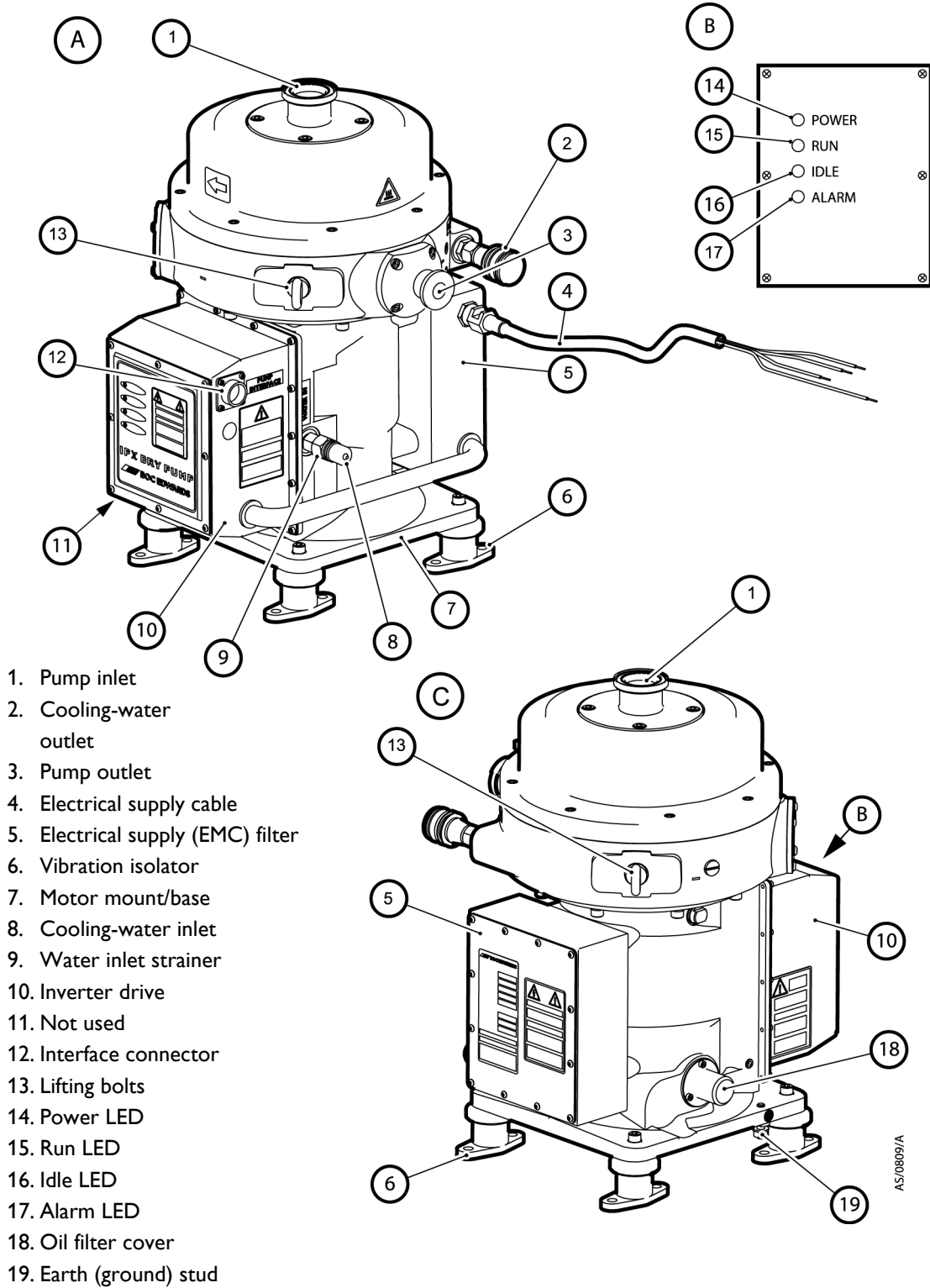
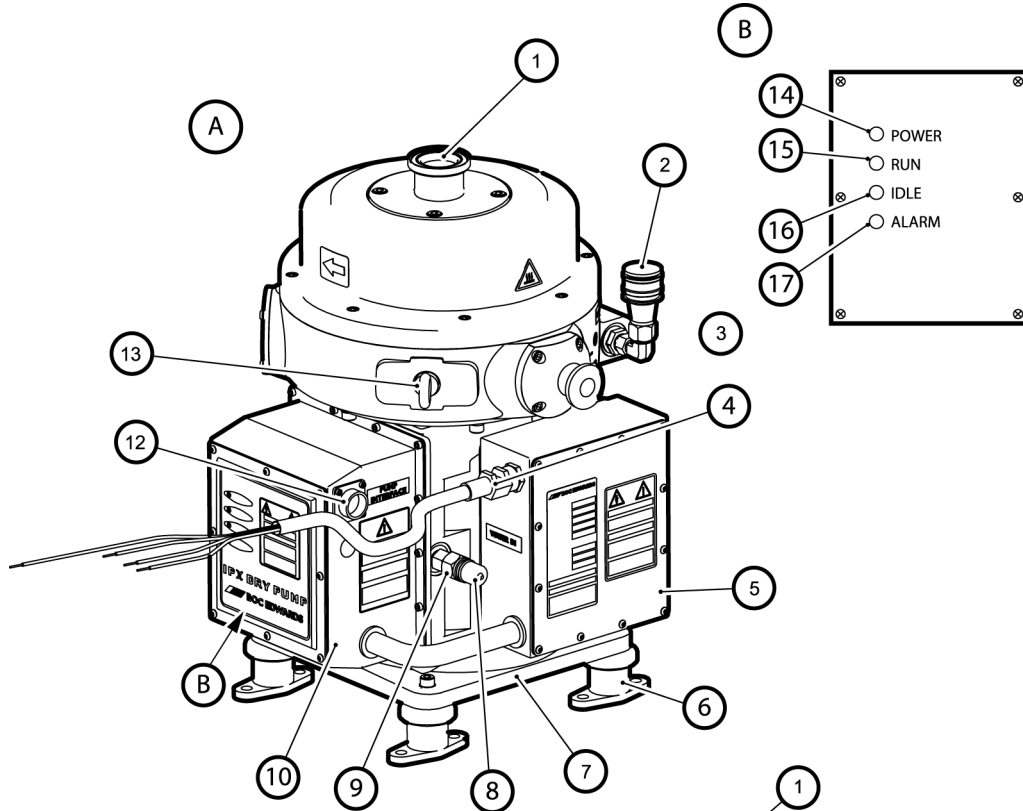

Figure 2 - The IPX pump

**IPX Dry Vacuum Pumps**



1. Pump inlet (varies for different pump types, see Section 2.1)
2. Cooling-water outlet
3. Pump outlet
4. Electrical supply cable
5. Electrical supply (EMC) filter
6. Vibration isolator
7. Motor mount/base
8. Cooling-water inlet
9. Water inlet strainer
10. Inverter drive
11. Not used
12. Interface connector
13. Lifting bolts
14. Power LED
15. Run LED
16. Idle LED
17. Alarm LED
18. Oil filter cover
19. Earth (ground) stud

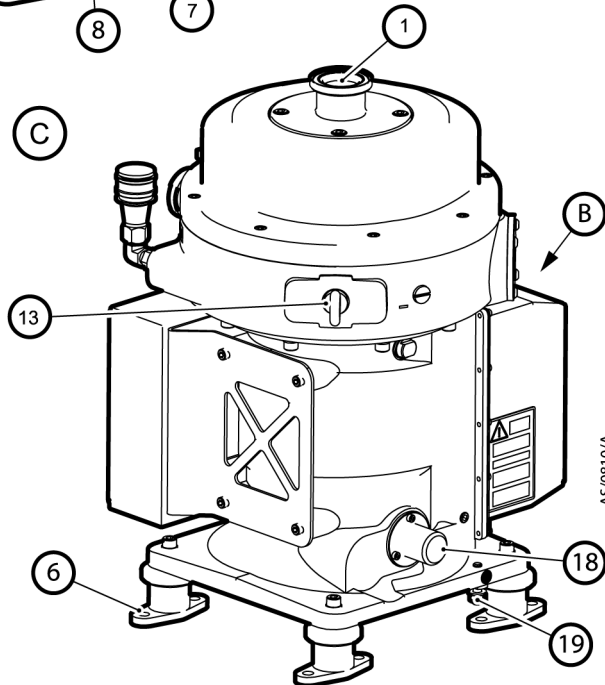

Figure 3 - The IPX A variant

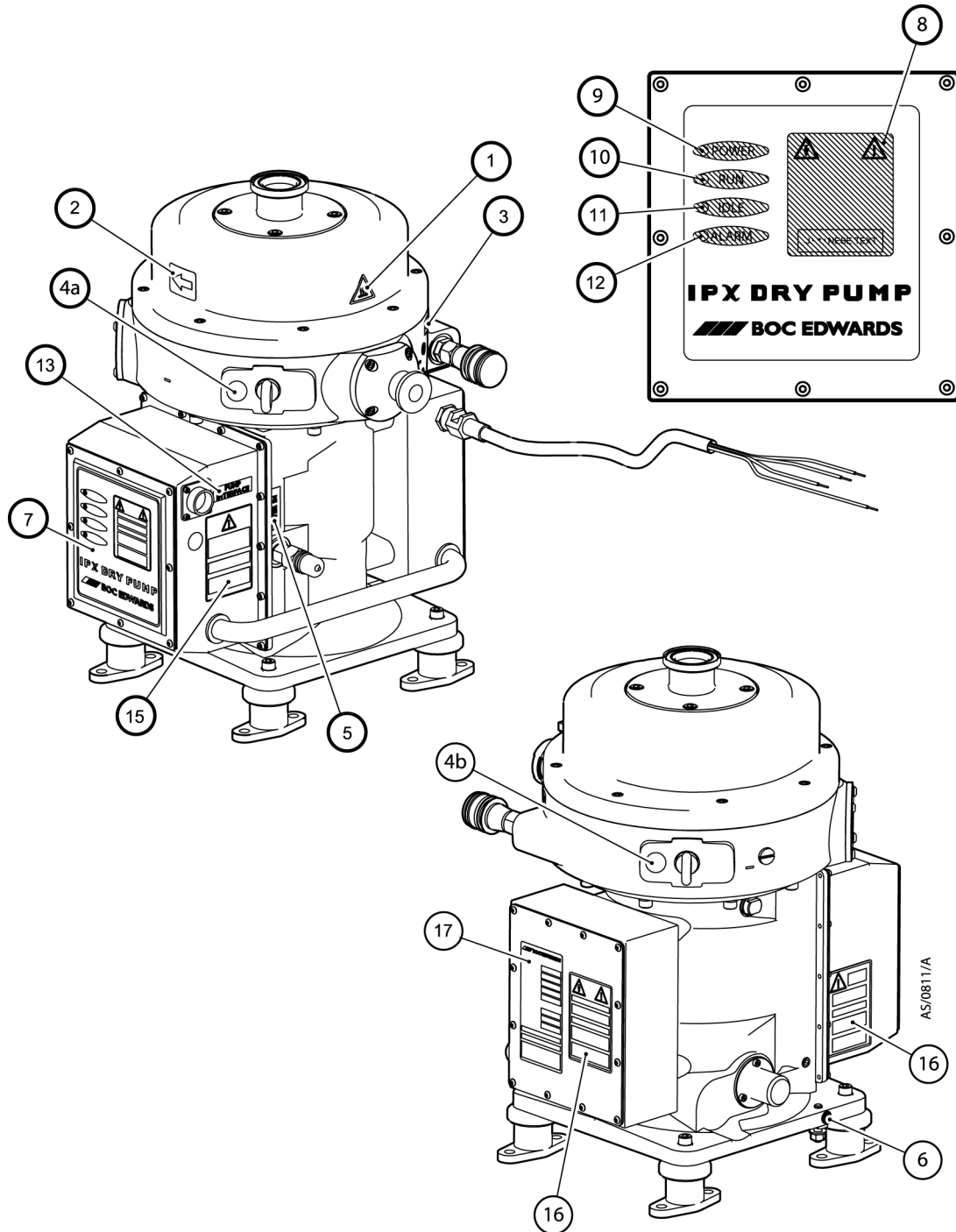

Figure 4 - Labels on the IPX pump

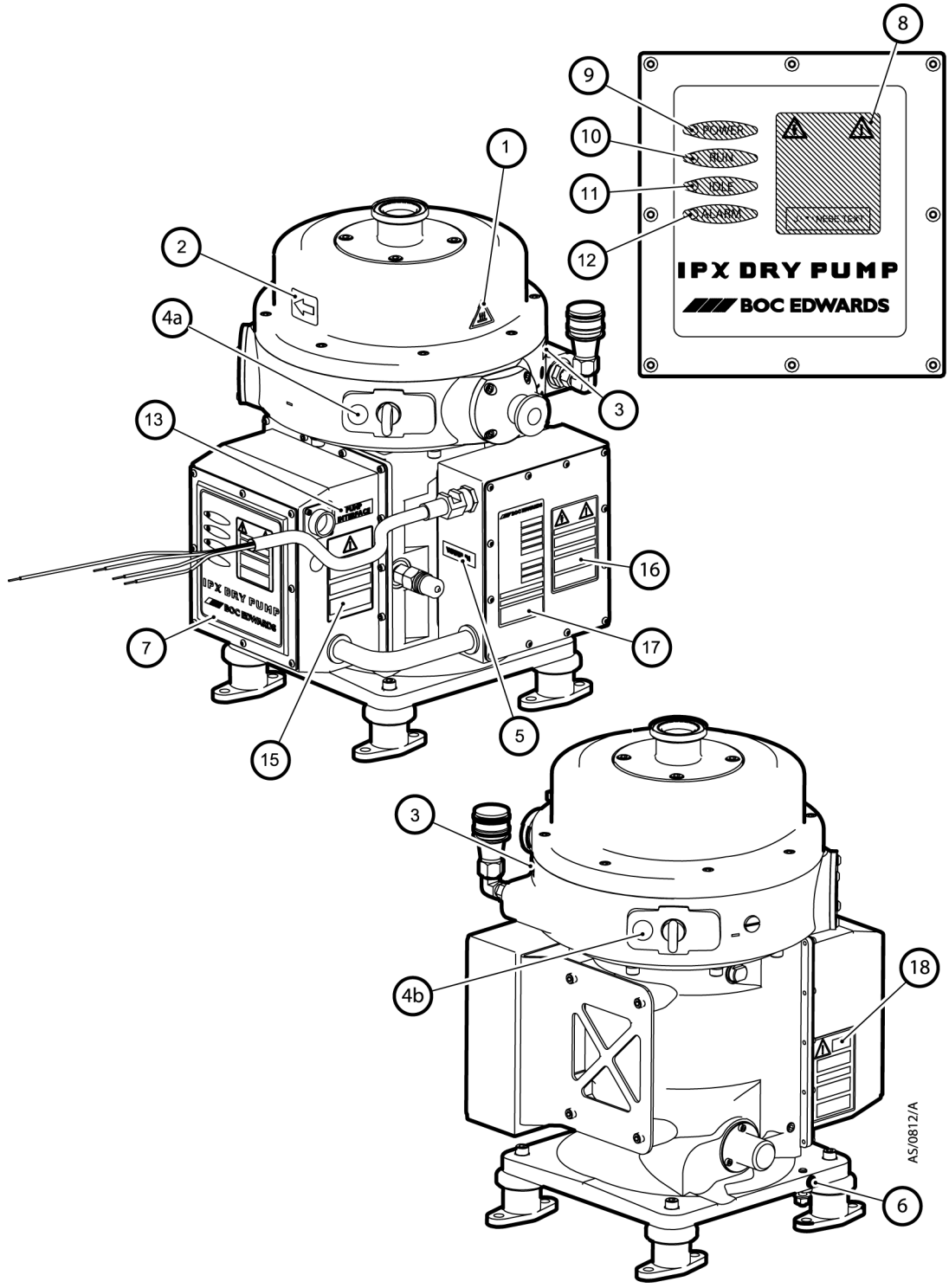

Figure 5 - Labels on the IPX A pump

**IPX Dry Vacuum Pumps**

Number	Label name	Description
1	Warning: risk of high temperature	During normal operating conditions temperatures will range between 40°C to 60°C. During limiting operating conditions temperatures may exceed 70°C.
2	Direction of rotation	The arrow shows the correct spin direction of the rotor.
3	Water out	The cooling-water return pipeline connects to the pump at this location.
4a and 4b	Lifting point	The pump must be lifted using the eyebolts on the pump and suitable lifting equipment.
5	Water in	The cooling-water supply pipeline connects to the pump at this location.
6	Protective conductor terminal	This equipment must have a second protective earth. See Section 3.11.
7	Drive cover label	Details information about numbers 8 - 12 below.
8	Warning: risk of electric shock	Do not remove cover until 4 minutes after disconnection of power.
9	Power	The power LED. See Table 1 for details.
10	Run	The run LED. See Table 1 for details.
11	Idle	The idle LED. See Table 1 for details.
12	Alarm	The alarm LED. See Table 1 for details.
13	Pump interface	The pump must be controlled through this 16 way Amp CPC, as instructed in Section 3.12.
14	Not used	
15	Thermal shock warning	If pump has overheated or cooling water has failed, connecting cooling water to a hot pump will cause severe damage to the pump. Always allow the pump to cool for at least 20 minutes before connecting cooling water. The cooling water connection contains a trapped filter. In the event of a blocked flow remove and clean. See Table 12.
16	Second protective earth	This equipment must have a second protective earth. See Section 3.11.
17	Pump details	This provides specific information about the pump including: pump type, code number, serial number, pump weight, year of manufacture and name and address of the manufacturer. It also details electrical supply requirements.
18	Warning: risk of electric shock	Do not remove cover until 4 minutes after disconnection of power.

Table 4 - Pump labelling information

## 2 TECHNICAL DATA

### 2.1 General

	IPX100/100A	IPX180A	IPX500A
Dimensions	See Figures 8 and 9		
Mass	55 kg; 121.25 lbs	59 kg; 130.00 lbs	60 kg; 132.27 lbs
Inlet	NW40	ISO63	ISO160
Inlet fittings	Use NW40 swing clamp and NW40 strainer fitted with the pump	One ISO63 centring ring. 4 Claw clamps	One ISO160 centring ring. 8 Claw clamps
Outlet	NW25		
Ambient operating temperature range	5 to 40°C, 41 to 104°F		
Maximum ambient operating humidity	90% RH @ 20°C -50%RH @40°C		
Noise level	<59dB(A)		
Maximum operating tilt angle	5°		
Handling	The pump must not be laid on its side or inverted Topple angle 15°		
Maximum exhaust pressure	<1200 mbar absolute <900 Torr absolute		

Table 5 - General

### 2.2 Performance

	IPX100/100A	IPX180A	IPX500A
Warm-up time (to nominal performance)	30 minutes		
Peak pumping speed	100 m <sup>3</sup> hr <sup>-1</sup> 58.9 cfm	175 m <sup>3</sup> hr <sup>-1</sup> 103.0 cfm	500 m <sup>3</sup> hr <sup>-1</sup> 294.3 cfm
Ultimate vacuum*	<5 x 10 <sup>-3</sup> mbar, <0.5 Pa, <3.7 x 10 <sup>-3</sup> Torr	<1 x 10 <sup>-4</sup> mbar, <1 x 10 <sup>-2</sup> Pa, <7.5 x 10 <sup>-5</sup> Torr	<1 x 10 <sup>-6</sup> mbar, <1 x 10 <sup>-4</sup> Pa, <7.5 x 10 <sup>-7</sup> Torr
Idle vacuum	750 mbar, 7.5 x 10 <sup>4</sup> Pa, 560 Torr		
Maximum leak rate	1 x 10 <sup>-5</sup> mbar ls <sup>-1</sup> , 1 x 10 <sup>-3</sup> Pa ls <sup>-1</sup> , 2.1 x 10 <sup>-8</sup> atm ft <sup>3</sup> min <sup>-1</sup>		

Table 6 - Performance

\* The time taken to reach ultimate vacuum is dependent upon vacuum system cleanliness and foreline conductance.

2.3 Electrical data

Electrical items	Reference data
Electrical supply	200/208V, 50/60Hz, 400V, 50/60Hz 3-phase
Voltage tolerance	±10%
Electrical power	
Full load	3.3 kW
At ultimate vacuum (no load)	2.2 kW
At idle	0.6 kW
Fuse/isolator rating*	20 A current limiting Class CC rated to 600V
Installation (over-voltage) category	Class II
Pollution degree	1
Minimum earth (ground) cable rating	32 A
Electrical supply plug (fitted to 200/208V variants only)	Hubbell Twist-Lock Insulgrip, Part No. 2421
Interface connector	
Parallel pump interface	AMP 16-way CPC (male)
Nominal pin rating	24 V d.c., 0.25 A
Shut-down thermal snap-switch	
Opening temperature	55°C, 131°F
Closing temperature	44°C, 111°F

Table 7 - Electrical data

\* The mains disconnect device AIC (Amperes Interrupting Capacity) must be rated to at least 10 000 A. See clause 13 of SEMI S2 - 0200 and SEMI S8 for further details.

2.4 Cooling-water supply

Cooling-water items	Reference data
Maximum supply pressure	7.89 bar absolute, 7.89 x 10 <sup>5</sup> Pa, 100 psig
Minimum required pressure differential across supply and return	2.07 bar, 2.07 x 10 <sup>5</sup> Pa, 30 psig
Maximum supply temperature	35°C
Minimum supply temperature	15°C
Maximum particle size in supply	0.03 mm <sup>2</sup> , 4.6 x 10 <sup>-5</sup> inch <sup>2</sup>
Typical heat removed from IPX pump	2 kW, 6824 btu h <sup>-1</sup>
Minimum water flow rate	2 l min <sup>-1</sup> , 31.7 US gallons h <sup>-1</sup>
Connectors	
Inlet	3/8 inch BSP quick-release (male)
Outlet	3/8 inch BSP quick-release (female)
Model type	Hanson 72 Series Stainless Steel Couplings

Table 8 - Cooling water supply



2.5 Materials in contact with process gases

Material items	Reference data
Pump-body	Aluminium LM25
Pump rotor	Hard anodised aluminium, PTFE impregnated
Internal shaft seals	PTFE coated stainless steel
'O' rings	Viton fluoroelastomer
Bump stop	Stainless steel
Pump shaft	Carbon steel

Table 9 - Materials in contact with process gases

**IPX Dry Vacuum Pumps**

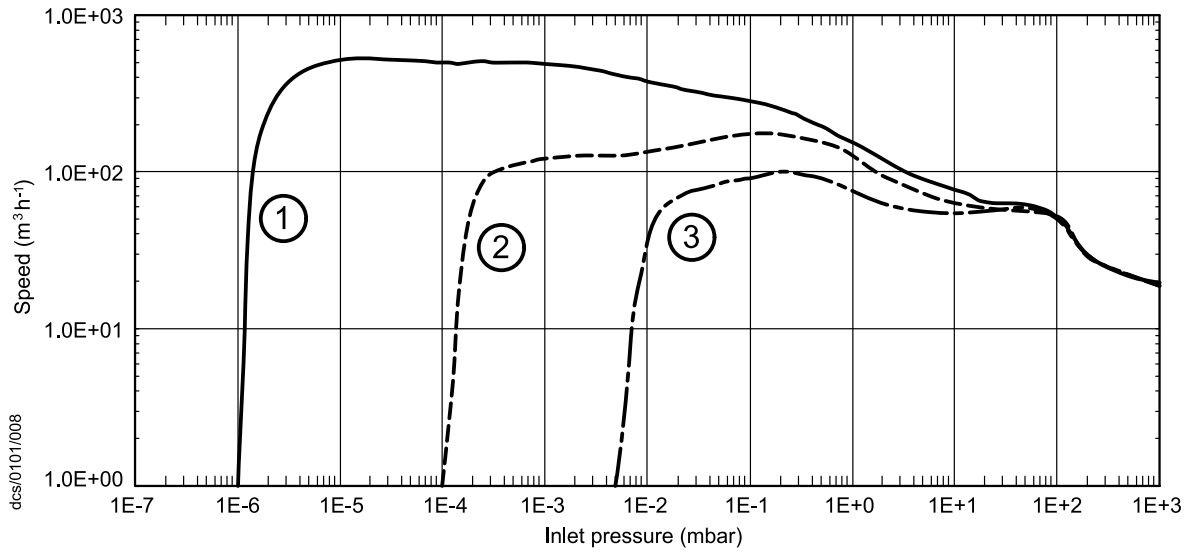

1. IPX500A
2. IPX180A
3. IPX100; IPX100A

Figure 6 - Speed curve (mbar-cmh)

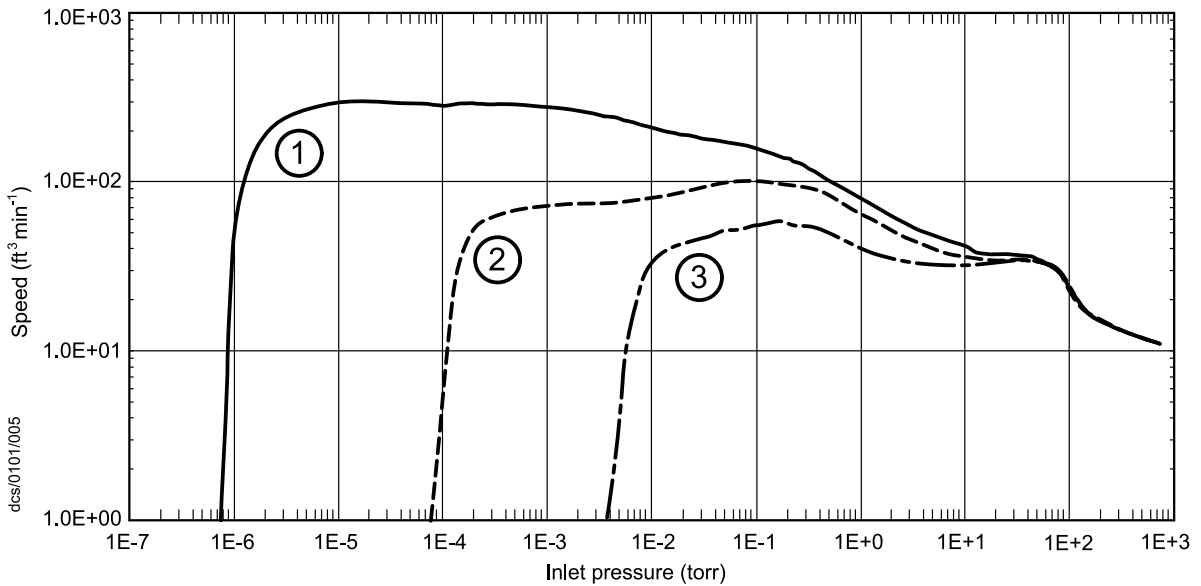

1. IPX500A
2. IPX180A
3. IPX100; IPX100A

Figure 7 - Speed curve (Torr - cfm)

**IPX Dry Vacuum Pumps**

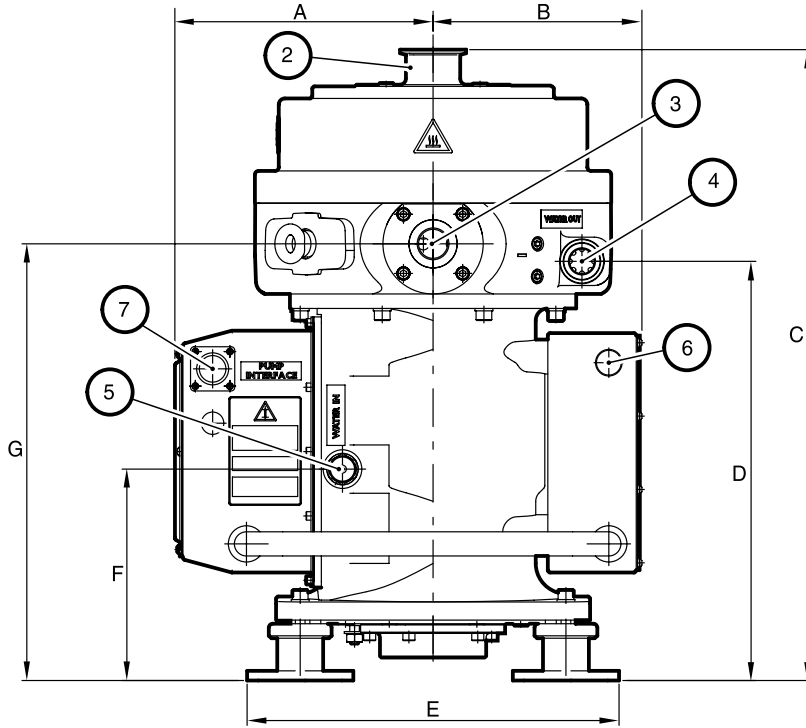

	mm	inches
A	214	8.4
B	173	6.8
C (IPX100)	522	20.6
D	347	13.7
E	308	12.1
F	175	6.9
G	361.5	14.2
H	200	7.9
I	347.5	13.7
J	110	4.3
K	142	5.6
L	284	11.2
M	64	2.5
N	220	8.7
O	123	4.8
P	21	0.8

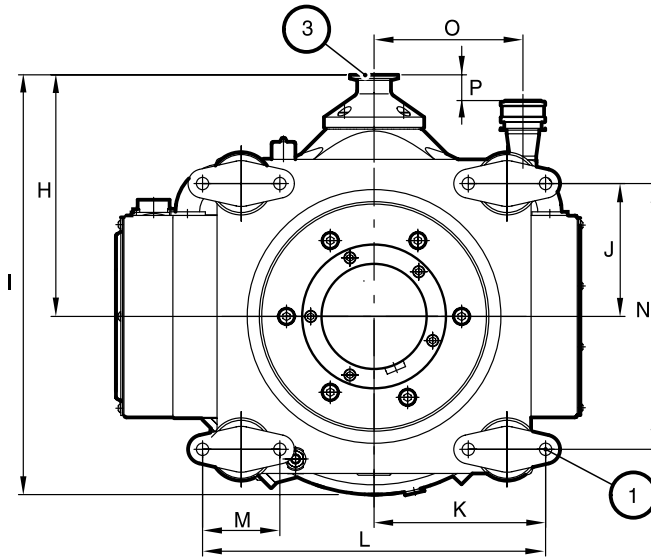

dcs/0115/006

- 1. Fixing hole: Ø10.2mm, 0.4 inches
- 2. Pump inlet
- 3. Pump outlet
- 4. Cooling-water outlet
- 5. Cooling-water inlet
- 6. Electrical supply
- 7. Pump interface

Figure 8 - IPX installation dimensions

**IPX Dry Vacuum Pumps**

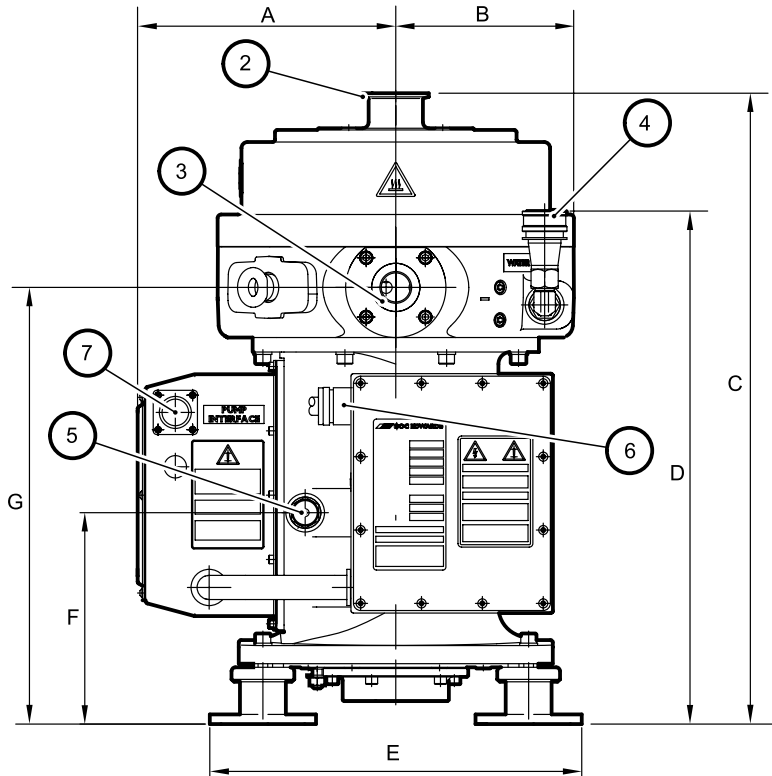

	mm	inches
A	214	8.4
B	147	5.8
C (IPX100A/180A)	522	20.6
C (IPX500A)	531	20.9
D	425	16.7
E	308	12.1
F	175	6.9
G	361.5	14.2
H	200	7.9
I	347.5	13.7
J	110	4.3
K	142	5.6
L	284	11.2
M	64	2.5
N	220	8.7
O	123	4.8
P	37.5	1.5

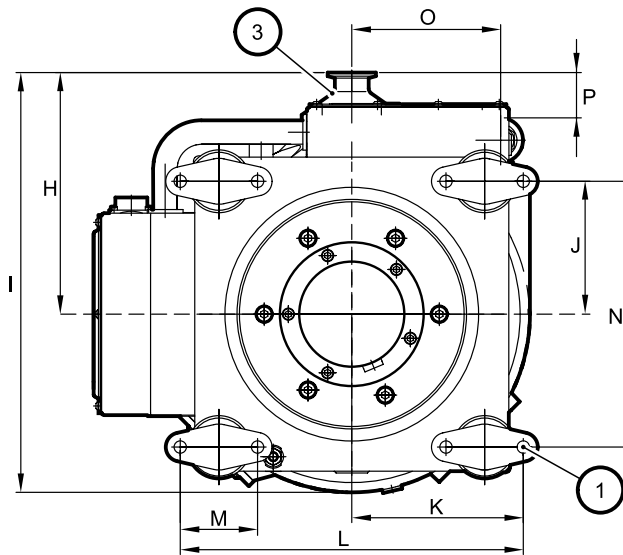

dcsl/0115/007

- |  |                         |
|--|-------------------------|
| 1. Fixing hole: $\varnothing 10.2$ mm, 0.4 inches              | 4. Cooling-water outlet |
| 2. Pump inlet (geometry varies with pump type see Section 2.1) | 5. Cooling-water inlet  |
| 3. Pump outlet   | 6. Electrical supply    |
|  | 7. Pump interface       |

Figure 9 - IPX A installation dimensions

### 3 INSTALLATION

#### 3.1 Safety

	<p style="text-align: center; margin: 0;"><b>WARNING</b></p> <p>Obey the safety instructions given below and take note of appropriate precautions. If you do not, you can cause injury to people and damage to equipment.</p>
---	---

- Ensure that the IPX pump is suitable for your application. The IPX pump is designed for clean duty chambers using air, nitrogen or inert gases. Contact BOC Edwards or your supplier if you want to use the IPX pump on any other application.
- Ensure that you comply with all local and national safety requirements during installation.
- Ensure that the installation technician is familiar with the safety procedures which relate to the products pumped. Wear the appropriate safety-clothing when you come into contact with contaminated components. Dismantle and clean contaminated foreline components inside a fume-cupboard. The IPX pump should NOT be dismantled under any circumstances.
- Vent and purge the process system before you start installation work.
- Disconnect the other components in the process system from the electrical supply so that they cannot be operated accidentally.

#### 3.2 Unpack and inspect

	<p style="text-align: center; margin: 0;"><b>WARNING</b></p> <p>Use suitable lifting equipment to move the pump. Refer to Section 2 for the pump mass.</p>
---	--

*Note:* A 'tip and tell' indicator is fitted to the IPX pump packaging to indicate any damage or mishandling during shipment. If the indicator shows that the IPX pump has been tilted or mishandled during shipment, ensure that you inspect the IPX pump carefully for damage.

1. Use suitable lifting equipment attached to the lifting bolts (Figures 2 and 3, item 13) to move the IPX pump into a convenient position, then remove any protective packaging and covers.
2. Inspect the pump. If the pump is damaged notify your supplier and the carrier in writing within three days; state the Item Number of the IPX pump together with your order number and your supplier's invoice number. Retain all packing materials for inspection. Do not use the pump if it is damaged.
3. If the IPX pump is not to be used immediately, replace the packing materials. Store the IPX pump in suitable conditions as described in Section 6.

#### 3.3 Locate the IPX pump

	<p style="text-align: center; margin: 0;"><b>WARNING</b></p> <p>Use suitable lifting equipment to move the pump. Refer to Section 2 for the pump mass.</p>
---	--

	<p><b>WARNING</b></p> <p>Secure the IPX pump in its operating location. If you do not and the pump fails during operation, movement of the pump may damage equipment and injure people.</p>
---	---

1. Use suitable lifting equipment attached to the lifting bolts (Figures 2 and 3, item 13) to move the IPX pump into its required operating position. When installed, the IPX pump must be level: refer to Section 2.1.
2. Fit suitable M8 bolts, nuts and washers through the fixing holes (Figures 8 and 9, item 1) to secure the IPX pump to the floor, or to a frame; the floor or the frame must be able to withstand a reaction torque of at least 1000 Nm (738 lb ft), applied rotationally about the vertical axis of the pump for at least 10 ms.

**3.4 Connect the inlet to your process system**

	<p><b>WARNING</b></p> <p>Install the pump in the vacuum system before you connect the pump to the electrical supply. If you do not, the pump may operate during installation and cause injury to people and damage to the surrounding equipment.</p>
---	--

For IPX100 pumps, remove the blanking cap from the inlet (Figures 2 and 3, item 1), then use a suitable clamp and seal to connect the inlet to your process system.

	<p><b>WARNING</b></p> <p>Do not remove the Inlet screen from the pump. Do not operate the pump with the Inlet exposed.</p>
---	--

When you connect the pump to the process system:

<p><b>CAUTION</b></p> <p>The vacuum system and foreline assembly <b>must not</b> be supported by the IPX Pump.</p> <p>The foreline assembly should be supported by the vacuum system and connected to the IPX pump inlet by a flexible connection to reduce vibration and stress in the system pipelines.</p>
---

- Use a flexible connection in the pipeline from the process system to the pump to reduce vibration and stress in the system pipelines.
- You must be able to isolate the pump from the atmosphere and from your process system if you have pumped or produced dangerous substances.
- To get the best pumping speed, ensure that the pipeline which connects the process system to the pump is as short as possible and has an internal diameter not less than the pump inlet.
- Do not allow debris to get into the pump during installation. Ensure that debris (such as weld slag) cannot get into the pump during operation.
- If necessary, contact BOC Edwards or your supplier for advice on inlet isolation valves or other components suitable for your application and system design.

**3.5 Connect the inlet to your process system (extra notes for IPX180A and IPX500A)**

The IPX180A and IPX500A pumps are supplied with a clear plastic protective cap on the inlet flange. The cap prevents debris entering the pump during transit and protects the inlet flange from scratches.

The plastic cap **must** be removed prior to installation and operation of the pump.

Connect the inlet flange to a foreline or inlet reducing adapter, using an Edwards centring 'O' ring and claw clamps (Refer to Section 2.1 for details of fittings).

A centring 'O' ring must be used to seal the inlet flange and retain the inlet screen.

	<b>WARNING</b>
	The IPX500A pump is capable of generating significant vacuum forces. To ensure safe operation, secure the IPX pump in its operating location as referred to in Section 3.3.

**3.6 Connect the outlet to your exhaust extraction system**

	<b>WARNING</b>
	Pipe the exhaust to a suitable treatment plant to prevent the discharge of dangerous gases or vapours to the surrounding atmosphere.

	<b>WARNING</b>
	Do not incorporate check-valves or one-way valves in the exhaust pipeline. If you do, the IPX pump will not operate correctly and may be damaged.

<b>CAUTION</b>
Install an outlet catchpot to prevent the drainage of condensate back into the pump. If you do not, condensate which drains back into the pump may damage it or cause it to seize.

*Note: If your exhaust extraction system is unrestricted, and so cannot be sealed for leak test purposes, you must leak test the system (refer to Section 3.7) before you connect the pump outlet.*

Remove the blanking cap from the outlet (Figures 2 and 3, item 3), then use a suitable clamp and seal to connect the outlet to your exhaust pipeline. Take note of the following when you connect to the exhaust pipeline:

- If your exhaust pipeline incorporates any shut-off valves, you must be able to prevent operation of the pump when any of the valves are closed (that is, the pipeline is restricted or blocked). If the IPX pump operates when the pipeline is restricted or blocked, the pump will not operate correctly and may be severely damaged.
- Incorporate flexible bellows in the exhaust pipeline to reduce the transmission of vibration and to prevent the loading of coupling-joints. If you use flexible bellows, you must ensure that you use bellows which have a maximum pressure rating which is greater than the highest pressure that can be generated in your system, and which can withstand the maximum temperatures that can be generated by your process conditions.
- The exhaust pipeline must be a minimum diameter of NW25 throughout.

**3.7 Leak test the system**

	<b>WARNING</b>
	Leak test the system and seal any leaks found to prevent the leakage of dangerous substances out of the system and leakage of air into the system.

*Note: If your exhaust extraction system is unrestricted, and so cannot be sealed for leak test purposes, you must leak test the system before you connect to the pump outlet.*

Leak test the system, then seal any leaks found. Substances which leak from the system may be dangerous to people, and there may be a danger of explosion if air leaks into the system.

As supplied, the leak rate of the IPX pump is tested to be less than  $1 \times 10^{-5}$  mbar  $\text{ls}^{-1}$  ( $1 \times 10^{-3}$  Pa  $\text{ls}^{-1}$ ,  $2.1 \times 10^{-8}$  atm.ft<sup>3</sup> min<sup>-1</sup>). The required leak rate for your system will depend on your safety and process requirements.

### 3.8 Connect the cooling-water supply

Take note of the following when you connect the cooling-water supply and return pipelines:

- Route and secure cables, hoses and pipe-work neatly during installation to avoid possible risk of trips.
- Wipe up any water spilt during installation to avoid possible risk of slips.
- If you need to connect more than one IPX pump to the water supply, you must connect them in parallel and not in series.
- We recommend that you incorporate a suitable ball-type flow indicator in your water return pipeline, to provide a visual indication of cooling water flow through the IPX pump.
- We recommend that you incorporate a suitable filter in the water supply pipeline, if the water supply contains particulates. (For the cooling-water supply specification refer to Section 2.4).
- To prevent damage to the pump in the event of cooling-water supply failure or a blockage in the pump, we recommend that you incorporate a suitable flow-switch in the cooling-water return pipelines. You can connect the outputs of the flow-switch to your control equipment to shut down the pump if the cooling-water flow through the pump gets too low.
- To conserve resources we recommend that the water return is cooled and re-circulated.

Connect the cooling-water supply as follows:

1. Fit a suitable female quick-release connector (not supplied) to your cooling-water supply pipeline (refer to Section 2.4).
2. Fit a suitable male quick-release connector (not supplied) to your cooling-water return pipeline (refer to Section 2.4).
3. Refer to Figures 2 and 3. Remove the yellow blanking-caps from the cooling-water inlet (8) and outlet (2).
4. Fit the male quick-release connector on your cooling-water return pipeline to the cooling-water outlet (2).
5. Fit the female quick-release connector on your cooling-water supply pipeline to the cooling-water inlet (8).
6. Do not turn on the cooling-water supply yet.

### 3.9 Connect the cooling-water (extra notes for IPX A pumps)

The IPX A has an adjustable water out port. This can be orientated to suit the user. Guidelines to do this are detailed below:

1. Using an 11/16" (18 mm) spanner, loosen the nut on the male elbow joint by applying a ¼ turn clockwise (as shown in Figure 10).
2. Re-position the quick connect socket to accommodate the connection of the system cooling-water pipes. (The socket can rotate within an arc of 180°).
3. Tighten the nut on the male elbow joint by turning it anti-clockwise.
4. Fit the male quick-release connector on your cooling-water return pipeline to the water outlet port on the pump.
5. Do not turn on the cooling water supply yet.



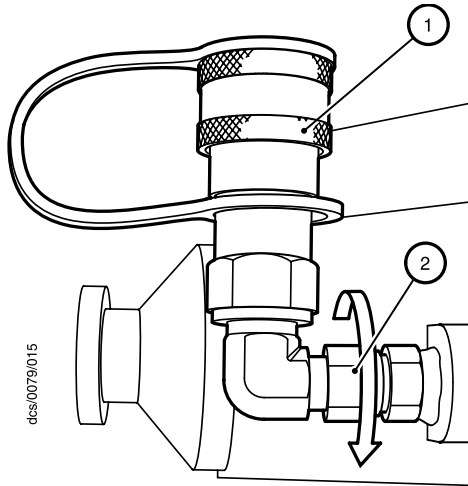

1. Quick connect socket
2. Male elbow joint nut

Figure 10 - Water-out port

**3.10 Connect to your emergency stop circuit**

Refer to Figure 11. The pump must be connected to an emergency stop facility. The operation of the emergency stop function should immediately disconnect power from the pump when the emergency stop control is operated. Returning the emergency stop control to its normal operating position should not result in power being re-applied to the pump; a separate start or reset control should be used for this.

The emergency stop control must be compliant with [IEC 60947-5-1]. (This should be a red self latching mushroom push button on a yellow background.)

**3.11 Connect the IPX pump to the electrical supply**

	<p><b>WARNING</b></p> <p>Connect the electrical supply to the IPX pump through a suitable fuse/ isolator rated as specified in Section 2.3.</p>
---	---

	<p><b>WARNING</b></p> <p>Do not operate the IPX pump unless it is correctly earthed (grounded).</p>
---	---

*Note: If you connect the electrical supply to the IPX pump through ELCB relays, they must be suitable for the protection of equipment with a d.c. component in the fault current, and suitable for short-duration switch-on surges, and for high leakage currents (for example, type B, according to prEN50178).*

Refer to Figures 2 and 3. The IPX pump is supplied with an integral supply cable (4); an electrical supply plug is fitted to the end of the cable for 200/208V variants only. Use the following procedure to connect the IPX pump to the electrical supply:

1. Use a suitable earth (ground) cable to connect the earth (ground) stud (19) on the IPX pump to a suitable earth (ground) point: refer to Section 2.3 for the cable rating.
2. If an electrical supply plug is not fitted:
  - Connect the four core electrical supply cable to earth and three phases by direct connection to a suitable control box with a means of isolation, and by means of a suitably IP rated four pin connector.

	<p><b>WARNING</b></p> <p>Ensure that the electrical supply and connectors are rated for the voltage of the pump as marked on the rating label attached to the electrical supply (EMC) filter (5).</p>
---	---

- Fit a suitable four-core electrical supply cable to a suitable electrical supply connector mating-half (not, supplied: refer to Section 2.3 for the plug type fitted to the IPX pump):

	<p><b>WARNING</b></p> <p>The electrical supply plug provided must not be used as the means to isolate power from the pump. Ensure the pump is isolated from the mains supply for 1 minute and ensure the power LED (Figures 2 and 3, item 14) is off before disconnecting the supply plug.</p>
---	--

- Connect the earth (ground) wire in your electrical supply cable to the earth (ground) socket in your connector mating-half.
  - Connect the three phase wires in your electrical supply cable to the phase sockets in your connector mating-half.
- Fit your connector mating-half to the electrical supply plug on the end of the electrical supply cable (4).

**3.12 Connect to your control equipment**

<p><b>CAUTION</b></p> <p>Do not connect voltages greater than 24 V to the IPX interface control. If you do, the interface control will not comply with the low voltage safety directive.</p>
--

Use a suitable mating-half (as specified in Section 2.3; not supplied) to connect your control equipment to the interface connector (Figures 2 and 3, item 12): use the pins in the connector as shown in Table 10.

dcs/0079/008

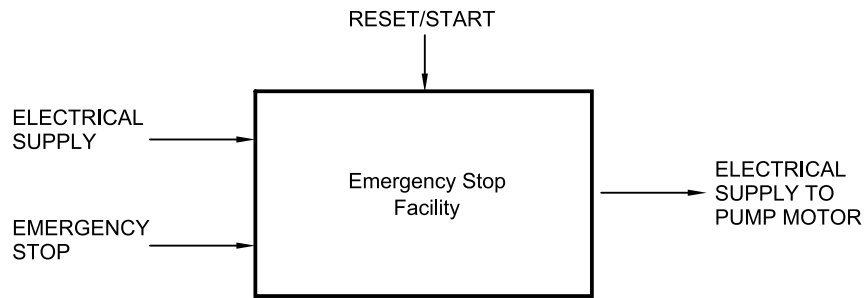

Figure 11 - Schematic diagram of emergency stop facility

**IPX Dry Vacuum Pumps**

Pin number	Signal name	Signal type	Use
1	Pump start/stop	Control input	Pump control common 0 V d.c.
2			Pump control signal 0V d.c. = off, 24V d.c. = on
3	Pump running	Status output	Open when the Run LED is off.
4			Closed when the Run LED is on.
5	-		Not used
6	-		Not used
7	-	Pins linked internally	Not used
8	-		
9	Pump alarm	Status output	Open when the pump Alarm LED is on.
10			Closed when the pump Alarm LED is off.
11	-	Pins linked internally	Not used
12	-		
13	-	Pins linked internally	Not used
14	-		
15	Pump idle on/off	Control input	Pump control 0 V d.c.
16			Pump control signal 0V d.c. = off, 8-24V d.c. = on

Table 10 - Interface connector signals

This page intentionally blank.

## 4 OPERATION

	<p><b>WARNING</b></p> <p>Do not operate the pump when the exhaust pipeline is restricted or blocked. If you do, the IPX pump can generate pressures up to 11 bar (<math>1.1 \times 10^6</math> Pa) and be damaged.</p>
---	--

*Note: If the electrical supply to the IPX pump fails for only a few seconds, the pump will continue to operate normally provided the run signal on the interface is maintained.*

### 4.1 Start-up

1. Switch on the cooling-water supply and check that there are no leaks. If there are any leaks, switch off the cooling-water supply, seal the leaks, then switch on the cooling-water supply and check for leaks again.
2. Refer to Figures 2 and 3. Switch on the electrical supply to the IPX pump, then press the Reset button (11), and check that the Power LED (14) goes on; if the Power LED does not go on, refer to Section 5.6.
3. Check that the exhaust-extraction system is not restricted, and that any valves in the exhaust-extraction system are open.
4. Use your control equipment to set the pump start/stop signal to the interface connector (see Section 3.12) and check that the Run LED (15) goes on, and that the pump running status output closes. If the Run LED does not go on, or if the pump running status output remains open, refer to Section 5.6.

### 4.2 Manual shut-down

*Note: The pump can take up to three minutes to completely stop.*

Use the following procedure to shut down the pump.

1. Use your control equipment to reset the pump start/stop signal to the interface connector (see Section 3.12). The Run LED (Figures 2 and 3, item 15) will then go off, and the pump running status output signal will open.
2. If required (that is, if you will not use the IPX pump in the immediate future), switch off the electrical supply and the cooling-water supply.

### 4.3 Idle mode

The IPX pump has the option of running in a reduced frequency condition, enabling an energy saving during periods of non-use. Use your control equipment to set the pump idle signal to the interface connector (refer to Section 3.12). The idle mode will activate only when both an idle signal and a run signal are maintained. Once activated, the Idle LED (16) will start to flash and the pump will slow down to one third of its full running speed (refer to Table 6 for idle vacuum performance). The Idle LED (16) will remain on, and the pump will remain in the idle mode until the idle signal is removed. Once returned to normal running mode, the pump will take about 1.5 minutes to reach full running speed, and a further 3 minutes to recover a maximum vacuum performance.

### 4.4 Status and fault indications

Refer to Figures 2 and 3. During normal operation, only the Power and Run LEDs (14, 15) should be on, and the pump running, pump warning and pump alarm status outputs should be closed. If the Alarm LED (17) goes on, or if the pump alarm status output signal is open, refer to Section 5.6. To reset the pump from alarm mode, remove the mains power to the pump for 4 minutes. Re-apply the power only when the cause of the alarm has been resolved, refer to Section 5.6.

**4.5 Oil sightglass**

Refer to Figure 2, item 20. The top sight glass is a visual indication of the oil supply to the bearings in the pump. If there is no oil in the top of the sight glass once the pump has warmed up (5 minutes after start up), then contact BOC Edwards service personnel to inspect the pump.

**4.6 Automatic shut-down**

The IPX pump will automatically shut down if a pump protection sensor operates (see Section 1.3), or if the inverter drive fails. When the IPX pump automatically shuts down, the Alarm LED (Figures 2 and 3, item 17) goes on, and the pump alarm status output signal opens.

If the pump has shut down due to an over-temperature condition, it is advisable to check the cooling-water flow rate. If the water flow rate is not at the specification detailed in Section 2.4, the filter may have become blocked and should therefore be cleaned out. Guidelines for this are outlined in Section 4.7.

**4.7 Water filter inspection**

The IPX pump is fitted with a cooling-water filter (fitted inside the pump, see Figures 2 and 3 item 9). Only inspect the water filter if the pump has shut down due to an over temperature condition. To inspect for blockages and clean use the following method:

1. Refer to Figures 2 and 3. Place a suitable container under the cooling-water inlet and outlet (8,2). Disconnect your cooling-water supply and return pipelines. Allow the cooling-water to drain from the pump, by depressing the nipple on the inlet port (8).
2. Undo the cooling-water inlet fitting using a 19 mm (3/4") and a 22 mm (7/8") spanner (refer to Figure 11).

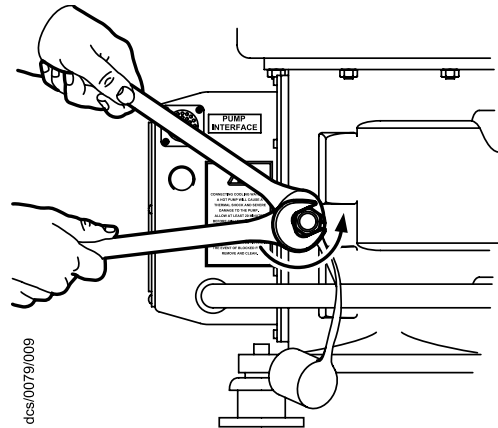

Figure 12 - Remove the filter inlet fitting

3. Carefully lever the filter out using a small flat headed screw driver (refer to Figure 12).

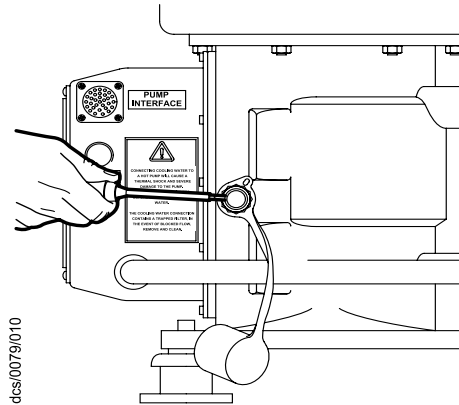

Figure 13 - Remove the filter

4. Flush the filter with water to remove all debris (refer to Figure 13).

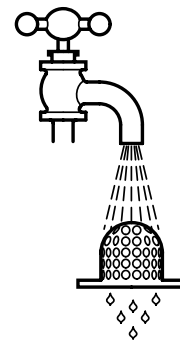

Figure 14 - Flush the filter

**IPX Dry Vacuum Pumps**

5. Refit the filter with the dome side facing inward.  
Tap the filter into place using a soft mallet.

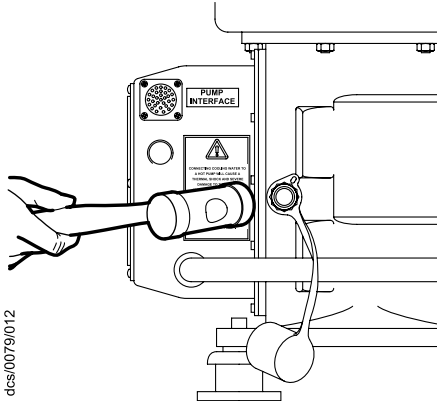

Figure 15 - Refit the filter

6. Seal the inlet thread using suitable thread sealant. Use sparingly to avoid further blockages.
7. Tighten the water fitting back onto the pump using 22 mm (7/8") and 19 mm (3/4") spanners.

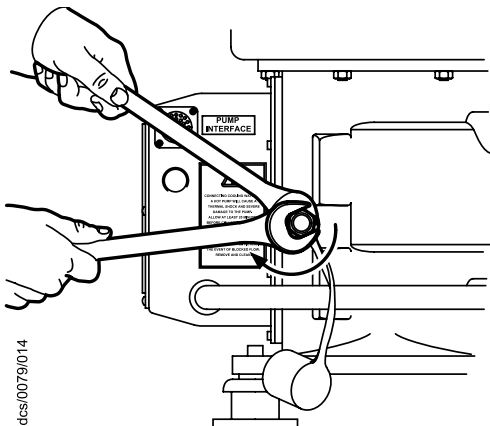

Figure 16 - Refit the filter inlet fitting

8. Reconnect the cooling-water supply and return pipelines. Check that there are no water leaks on the pump. (If there is a leak, recheck the thread sealant on the fittings).
9. Wipe up any spilt water so as to avoid possible risk of slips.

**4.8 Restart after automatic shut- down**

	<p><b>WARNING</b></p> <p>If the IPX pump automatically shuts down because the cooling-water supply is disconnected or has been switched off, wait for at least 20 minutes before you reconnect and switch on the cooling-water supply. If you do not, you could seriously damage the pump.</p>
--	--

*Note:* The pump can take up to five minutes to completely stop. Wait three minutes after the pump has been shut down before you try to restart it.

If the IPX pump automatically shuts down, you must identify and rectify the cause of the shut-down before you restart the IPX pump (refer to Section 5.6).

After automatic shutdown, restart the IPX pump as described in Section 4.1.

**4.9 Removing the pump from the vacuum system**

When the IPX pump is disconnected from the vacuum system, avoid contact with, or inhalation of any gases or particulates which may be present in the pump.

This page intentionally blank.



## 5 MAINTENANCE

	<p><b>WARNING</b></p> <p>The IPX pump is not suitable for on-site maintenance, servicing or repair.</p> <p>The IPX pump should not be dismantled under any circumstances.</p>
---	---

- There are no user serviceable parts in the IPX pump mechanism, electric motor or electrical controls. Attempting to remove the pump rotor, separate the motor from the pump or remove electrical covers can cause injury to people or damage to equipment.
- It is recommended that all maintenance and service operations are done by qualified BOC Edwards Service Personnel, excepting:- Connection and inspection of pipelines and connections to foreline and exhaust. Routine external cleaning. Connection and disconnection to electrical power.

### 5.1 Safety

	<p><b>WARNING</b></p> <p>Obey the safety instructions given below and take note of appropriate precautions. If you do not you can cause injury to people and damage to equipment.</p>
---	---

- Allow the IPX pump to cool to a safe temperature before you start maintenance work.
- Wipe up any spilt water during maintenance so as to avoid possible risk of slips.
- Isolate the IPX pump and other components in the process system from the electrical supply so that they cannot be operated accidentally.
- Do not reuse 'O' rings if they are damaged.
- Protect sealing-faces from damage.

- Do not touch or inhale the thermal breakdown products of fluorinated materials which may be present if the IPX pump has overheated to 260°C (500°F) and above. These breakdown products are very dangerous. The pump may have overheated if it was misused, if it malfunctioned, or if it was in a fire. BOC Edwards Material Safety Data Sheets for the fluorinated materials used in the IPX pump are available on request: contact your supplier or BOC Edwards. MSDS: Mechanical Pump Oil - Fomblin Y/ LVAC Series P120-01-015, 'O' rings - Viton P120-04-015.
- If you disconnect the inlet from the process system, leak-test the system after maintenance work is complete and seal any leaks found to prevent leakage of dangerous substances out of the system and leakage of air into the system: refer to Section 3.7.
- The inverter drive contains capacitors which store electrical energy after the pump has been shut down. Wait at least four minutes after the pump has been shut down before you start any work on the electrical system of the IPX pump.
- The inverter drive (see Figures 2 and 3, item 10) cover should not be removed as it contains sensitive electronic components. None of the components in the inverter drive are user serviceable.
- The electrical supply (EMC) filter cover (see Figures 2 and 3, item 5) may only be removed by a suitably trained and supervised electrical technician to replace a damaged mains supply cable. There are no other user serviceable parts.

### 5.2 Maintenance plan

The plan shown in Table 11 details the maintenance operations we recommend to maintain the IPX pump in normal operation. Instructions for each operation are given in the section shown.

**5.3 Inspect the pipelines and connections**

1. Inspect all cooling-water pipelines and connections; check that they are not corroded or damaged. Replace any of the pipelines and connections that are corroded or damaged. Check that all cooling-water connections are secure. Tighten any connections that are loose.
2. Inspect all electrical cables; check that they are not damaged and have not overheated. Replace any cables that are damaged or have overheated. Check that all electrical connections are secure. Tighten any connections that are loose.
3. Inspect all process and exhaust pipelines; check that they are not corroded or damaged. Replace any pipelines that are corroded or damaged. Check that all process and exhaust connections are secure. Tighten any connections that are loose.

**5.4 Cleaning the pump**

	<p style="text-align: center;"><b>WARNING</b></p> <p>Do not use cleaning materials based on strong alkalis, aggressive or chlorinated solvents.</p> <p>Do not use cleaning materials containing abrasives.</p>
---	--

Inspect the pump monthly and, if necessary, wipe the outside clean with a soft lint free cloth and a proprietary cleaning material based on demineralised water and, isopropanol or mild detergents.

**5.5 Service the IPX pump**

We recommend that the IPX pump is given a major service every five years. Major service is outside the scope of this manual and must be done by qualified BOC Edwards Service personnel: contact your supplier or BOC Edwards to arrange a major service.

For removal of the pump for maintenance refer to Section 6.

Operation	Frequency	Refer to Section
Inspect the pipelines and connections	Monthly	5.3
Cleaning the pump	Monthly	5.4
Service the IPX pump	5 yearly (clean process applications only)	5.5

Table 11 - Maintenance plan



This page intentionally blank.

## 6 STORAGE AND DISPOSAL

### 6.1 Storage

Store the pump as follows:

1. Ensure that the IPX pump has been shut down as described in Section 4.2, then disconnect the pump from the electrical supply.
2. Refer to Figures 2 and 3. Place a suitable container under the cooling-water inlet and outlet (8,2), then disconnect your cooling-water supply and return pipelines. Allow the cooling-water to drain from the pump, by depressing the nipple on the inlet port (8).
3. Disconnect the pump inlet (1) and outlet (3), from your process and exhaust pipelines.
4. Fit blanking-caps to the pump inlet (1) and pump outlet (3), and to the cooling-water inlet and outlet (8,2).
5. Store the pump in clean dry conditions until required.
6. When required for use, prepare and install the pump as described in Section 3 of this manual.

### 6.2 Disposal

Dispose of the IPX pump and any components safely in accordance with all local and national safety and environmental requirements.

The majority of the IPX packaging is made from recycled and/or recyclable materials. Contact BOC Edwards for further details.

Take particular care with the following:

- Fluoroelastomers which may have decomposed as the result of being subjected to high temperatures.

- Components that have been contaminated with dangerous process substances. Contaminated components must be disposed of, any remaining materials mentioned in Section 2.5, with the exception of 'O' rings, may be recycled.

This page intentionally blank.

## 7 SERVICE, SPARES AND ACCESSORIES

### 7.1 Introduction

BOC Edwards products, spares and accessories are available from BOC Edwards companies in Belgium, Brazil, Canada, France, Germany, Hong Kong, Italy, Japan, Korea, United Kingdom, USA and a worldwide network of distributors. The majority of these employ service engineers who have undergone comprehensive BOC Edwards training courses.

Order spare parts and accessories from your nearest BOC Edwards company or distributor. When you order, please state for each part required:

- Model and item number of your equipment.
- Serial number (if any).
- Item number and description of the part.

The following accessory kits are available for use with the IPX pump:

Kit Type	Item Number	Use
IPX Water Connection Accessory Kit	A409-01-800	This kit enables easy connection of the IPX pump to your house cooling-water supply and contains mating water connections for the pump.
IPX Electrical Interface Accessory Kit	A409-01-801	This kit enables easy connection of the IPX pump to your control equipment and contains mating plug, clamp and contacts for the parallel interface.

Table 13 - Accessory kits

### 7.2 Service

BOC Edwards products are supported by a worldwide network of BOC Edwards Service Centres. Each Service Centre offers a wide range of options including: equipment decontamination; service exchange; repair; rebuild and testing to factory specifications. Equipment which has been serviced, repaired or rebuilt is returned with a full warranty.

Your local Service Centre can also provide BOC Edwards engineers to support on-site maintenance, service or repair of your equipment.

For more information about service options, contact your nearest Service Centre or other BOC Edwards company.

This page intentionally blank.



### IPX Dry Vacuum Pumps

<b>A</b>				<b>T</b>	
Accessories	.....	33		Technical data	..... 9
Automatic shut-down	.....	24			
<b>C</b>				<b>U</b>	
Connections	.....	3		Unpack and inspect	..... 15
Control and monitoring	.....	3			
Cooling-water supply	.....	10		<b>W</b>	
<b>D</b>				Water filter inspection	..... 24
Disposal	.....	31			
<b>E</b>					
Electrical data	.....	10			
Emergency stop	.....	19			
<b>F</b>					
Fault finding	.....	29			
<b>I</b>					
Idle mode	.....	23			
Installation	.....	15			
Introduction	.....	1			
IPX pump labels	.....	3			
<b>L</b>					
Leak test the system	.....	17			
LEDs and reset button	.....	3			
<b>M</b>					
Maintenance	.....	27			
Maintenance plan	.....	27			
Manual shut-down	.....	23			
<b>O</b>					
Oil sightglass	.....	24			
OPERATION	.....	23			
<b>P</b>					
Performance	.....	9			
Pump protection sensors	.....	2			
<b>R</b>					
Restart after automatic shut- down	.....	25			
<b>S</b>					
Safety	.....	15			
Service	.....	33			
Spares	.....	33			
Start-up	.....	23			
Storage	.....	31			

This page intentionally blank.