

Instruction Manual

QMB Mechanical Booster Pumps

Description

Item Number

<i>QMB250F Mechanical Booster Pump, 50 Hz</i>	<i>A301-85-905</i>
<i>QMB250F Mechanical Booster Pump, 60 Hz</i>	<i>A301-86-905</i>
<i>QMB500F Mechanical Booster Pump, 50 Hz</i>	<i>A302-85-905</i>
<i>QMB500F Mechanical Booster Pump, 60 Hz</i>	<i>A302-86-905</i>
<i>QMB1200F Mechanical Booster Pump, 50 Hz</i>	<i>A305-85-905</i>
<i>QMB1200F Mechanical Booster Pump, 60 Hz</i>	<i>A305-86-905</i>

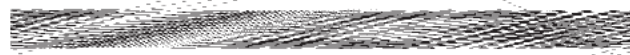

CONTENTS

Section	Title	Page
1	INTRODUCTION	1
1.1	Scope and definitions	1
1.2	Description	1
1.2.1	General	1
1.2.2	Construction	2
1.2.3	Principle of operation	2
1.2.4	Hydrokinetic fluid-coupling	2
1.3	Labels	4
2	TECHNICAL DATA	5
2.1	General	5
2.2	Electrical data	5
3	INSTALLATION	11
3.1	Safety	11
3.2	Unpack and inspect	12
3.3	Locate the pump	12
3.4	Fill the pump with oil	12
3.4.1	Coupling-cover	12
3.4.2	Shaft-seal reservoir	13
3.4.3	Gear-cover (QMB1200F only)	14
3.5	Cooling-water connections	14
3.6	Connect to your emergency stop system	14
3.7	Electrical connections	16
3.7.1	High and low-voltage operation	16
3.7.2	Motor connections	16
3.7.3	Motor-protection thermistors	17
3.8	Check the pump rotation	17
3.9	Connect the pump-inlet and outlet	20
3.10	External evacuation of coupling-cover (optional)	20
4	OPERATION	21
4.1	Operational safety	21
4.2	Start-up	21
4.3	Shut-down	22
5	MAINTENANCE	23
5.1	Safety	23
5.2	Maintenance plan	24
5.3	Check the oil-levels	24
5.4	Inspect the pump connections	25
5.5	Lubricate the rear-bearing (QMB250F and QMB500F only)	25
5.6	Change the pump oil	26

Section	Title	Page
6	STORAGE AND DISPOSAL	28
6.1	Storage	28
6.2	Disposal	28
7	SERVICE, SPARES AND ACCESSORIES	29
7.1	Introduction	29
7.2	Service	29
7.3	Spares	29
7.4	Accessories	30
7.4.1	QMB Booster Frames	30
7.4.2	QMB Booster Frame Connection Kits	30
7.4.3	QMB Booster Frame Acoustic Enclosures	30
7.4.4	QMB to QMKII Connection Kits	31

RETURN OF BOC EDWARDS EQUIPMENT

Illustrations

Figure	Title	Page
1	QMB Mechanical Booster Pumps (part cut-away)	3
2	Labels on the QMB pump	4
3	QMB250F dimensions	7
4	QMB500F dimensions	8
5	QMB1200F dimensions	8
6	Typical pumping speed for QDP40 and QMB250F pumping combinations	9
7	Typical pumping speed for QDP80 and QMB250F pumping combinations	9
8	Typical pumping speed for QDP80 and QMB500F pumping combinations	10
9	Typical pumping speed for QDP80 and QMB1200F pumping combinations	10
10	Sight-glasses	13
11	Schematic diagram of the emergency stop system	15
12	QMB250/500F low-voltage configuration	18
13	QMB250/500F high-voltage configuration	18
14	QMB1200F low-voltage configuration	19
15	QMB1200F high-voltage configuration	19
16	Lubricate the rear bearing (QMB250F and QMB500F only)	27

Tables

Table	Title	Page
1	Full load current ratings	5
2	Technical data	6
3	Maintenance plan	24

Associated publications

Publication title	Publication Number
Vacuum pump and vacuum system safety	P300-20-000
QMB Booster Connection Kits	A528-31-880
QMB Booster Frames	A528-37-880
QMB Booster Frame Connection Kits	A528-65-880
QMB Booster Frame Acoustic Enclosure	A528-70-880

(This page deliberately left blank)

1 INTRODUCTION

1.1 Scope and definitions

This manual provides installation, operation and maintenance instructions for the BOC Edwards QMB250F, QMB500F and QMB1200F Mechanical Booster Pumps. You must use the pumps as specified in this manual.

Read this manual before you install and operate the pump. Important safety information is highlighted as WARNING and CAUTION instructions; you must obey these instructions. The use of WARNINGS and CAUTIONS is defined below.

WARNING

Warnings are given where failure to observe the instruction could result in injury or death to people.

CAUTION

Cautions are given where failure to observe the instruction could result in damage to the equipment, associated equipment and process.

The units used throughout this manual conform to the SI international system of units of measurement.

1.2 Description

1.2.1 General

BOC Edwards QMB Mechanical Booster Pumps are compact and have high pumping speeds. Low system pressures can be achieved by using two or more mechanical booster pumps in series. You must use the QMB Mechanical Booster Pump with a suitable backing pump. The maximum continuous inlet pressure is 20 mbar for the QMB250F and QMB500F Mechanical Booster Pumps and 1 mbar for the QMB1200F Mechanical Booster Pumps.

The QMB250F and QMB500F pumps are air-cooled and the QMB1200F pump is water-cooled. All the QMB pumps have enclosed, water-cooled motors and are therefore suitable for applications in clean environments where fan cooling is unacceptable.

The pump coupling-cover is connected to the pump outlet and forms an integral part of the vacuum system. The connecting pipelines have a filter which removes debris and so prevents contamination of the lubricating oil and bearings. For an even cleaner system, the coupling-cover and bearings can be evacuated by connection to the pump-inlet or to an external vacuum pump.

Three motor-protection thermistors (one on each winding) are fitted to the motor of the QMB pump. These thermistors are solid-state devices which have an electrical resistance of 100 to 500 Ω at normal pump-motor operational temperature. When the pump-motor is too hot, the electrical resistance rises quickly to 3000 Ω .

The thermistors are connected in series and you can connect the thermistors to control equipment to automatically shut down the system if a pump-motor is too hot.

1.2.2 Construction

The QMB pumps are positive displacement Roots vacuum pumps. The pump mechanism is driven by a three-phase electric motor through a hydrokinetic fluid-coupling. The motor is enclosed and is cooled by integral cooling-water coils.

The pump shafts and rotors are made of high-grade, corrosion-resistant, cast-iron. The internal and external shaft-seals are made of polytetrafluoroethylene (PTFE) or fluoroelastomer.

The pump-bearings, gears and seals are lubricated by oil fed from reservoirs in the coupling-cover. A series of seals stops the oil from reaching the vacuum side of the pump. The coupling-cover is evacuated. You can inspect the oil-levels through sight-glasses which are fitted to the coupling-cover. Oil-filler, oil-drain and external evacuation connections are provided on the cover.

The QMB250F and QMB500F pumps have rear bearings which are lubricated by perfluoropolyether (PFPE) grease. The QMB1200F pump gears are lubricated by oil in the gear-cover. The gear-cover of the QMB1200F has oil-filler and oil-drain plugs and an oil-level sight-glass. The QMB pumps are suitable for use only with PFPE oils.

1.2.3 Principle of operation

The QMB Mechanical Booster Pump is shown in Figure 1. The motor-shaft drives one of the rotors through the fluid-coupling. The 1:1 gears inside the coupling-cover drive the second rotor in the opposite direction inside the stator housing. A small, accurately gauged, clearance is maintained between the rotors and between each rotor and the stator wall. This clearance allows the pump to operate at high speed without mechanical wear and without the need for lubrication inside the swept volume.

1.2.4 Hydrokinetic fluid-coupling

The hydrokinetic fluid-coupling connects the electric-motor shaft to the rotor. This system is configured so that when the gas-load is high the rotational speed of the rotors is reduced. As the gas-load decreases, the rotors accelerate to full speed. This allows continuous operation of the pump over the vacuum range without the risk of overloading the motor and removes the need for bypass-valves and associated pipelines.

1. Cooling-water bracket (QMB250F/QMB500F pumps)
2. Cooling-water bracket (QMB1200F pump)
3. Shaft-seal reservoir vented oil filler-plug
4. Coupling-cover oil filler-plug
5. Inlet-flange
6. End-cover (QMB250F/QMB500F)
7. External evacuation port
8. Rotors
9. Stator housing

10. Coupling-cover oil drain-plug
(under the pump)
11. Direction of rotation sight-glass
12. Oil-level sight-glasses
13. Electrical supply cable entry
14. Motor terminal-box cover
15. Gear-cover (QMB1200F)
16. Oil filler-plug (QMB1200F)
17. Oil drain-plug (under the gear-cover,
QMB1200F)
18. Oil-level sight-glass (QMB1200F)

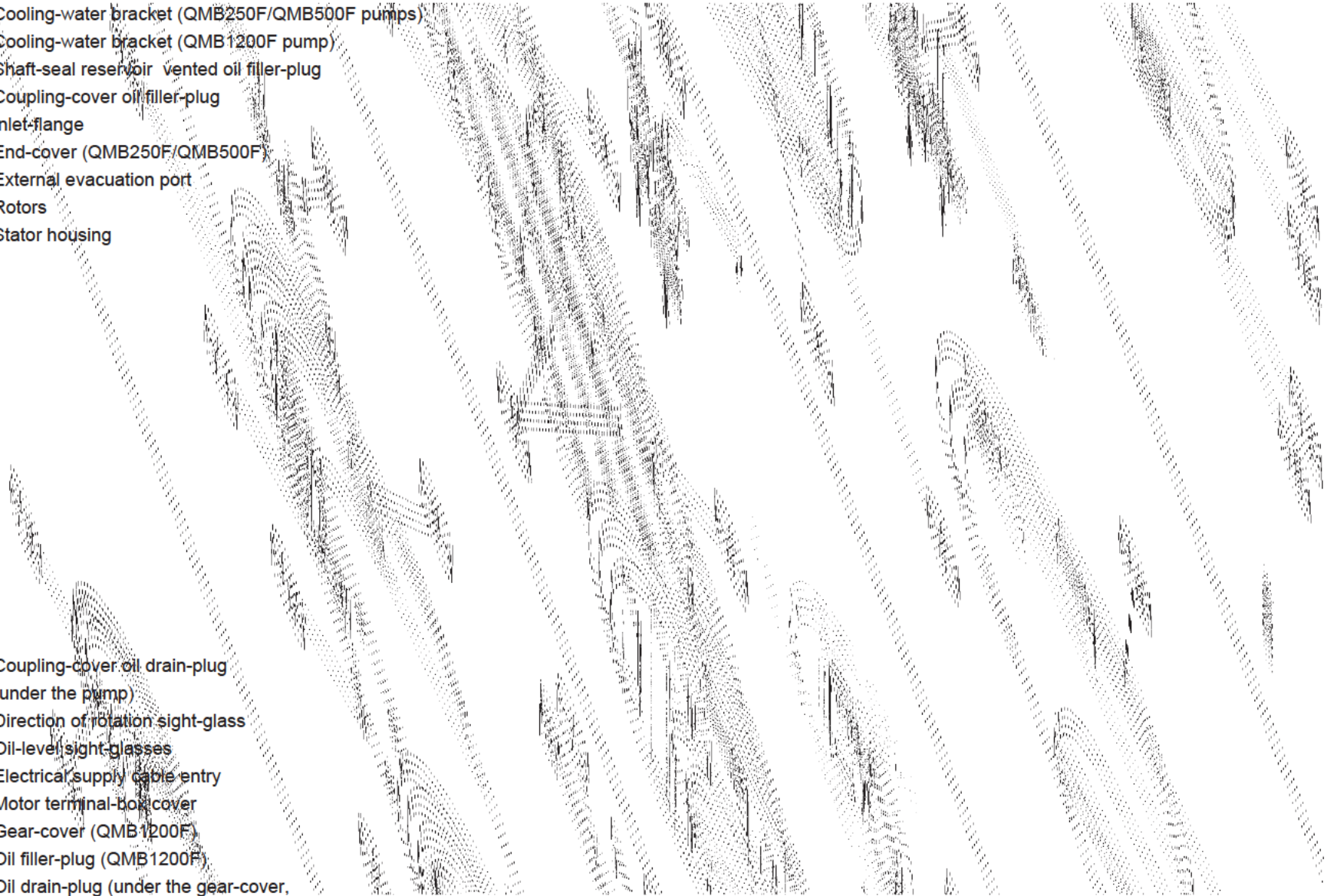

Figure 1 - QMB Mechanical booster pump (part cut-away)

1.3 Labels

Labels are fitted to the QMB pump in order to:

- Identify components.
- Define required installation/operation/maintenance procedures.
- Identify safety hazards.

Refer to Figure 2 which shows the positions of the labels fitted to the QMB pump.

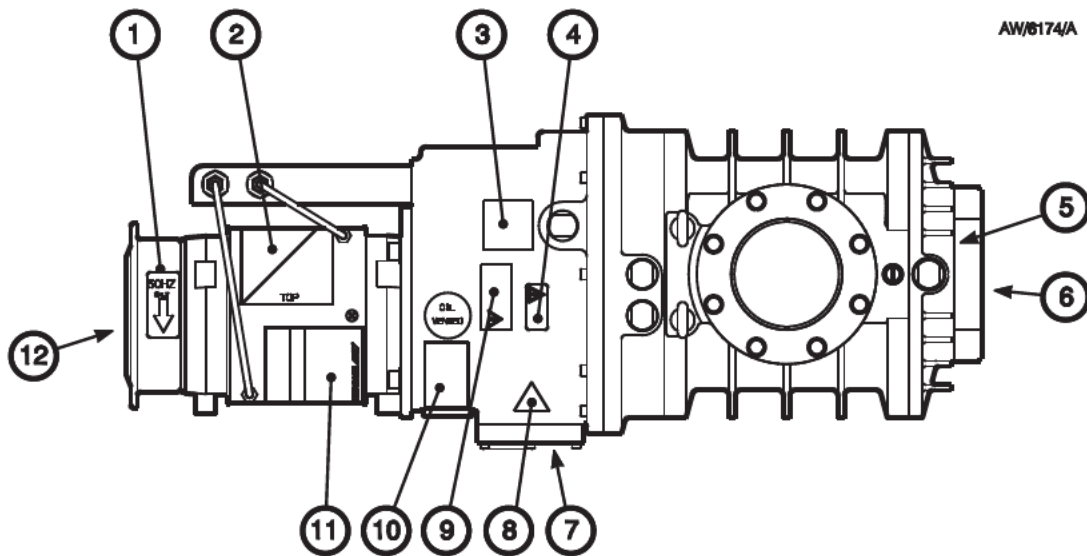

1. Direction of rotation arrow/frequency label
2. 'Do not step on/motor damage' label
3. Coupling cover filler plug/Oil level lower sight glass
4. 'Use only Fomblin Y16/6 or Krytox 1514 oil' label
5. 'Regrease bearing in accordance with instruction manual' label
6. QMB information/'Warning - Risk of high temperature' label
7. Caution symbol
8. 'Warning - Risk of high temperature' label
9. 'Caution - Do not not overfill with oil' label
10. 'Use vented plug only/Shaft seal reservoir' label
11. QMB motor rating information label
12. 'Warning - Risk of electric shock' label

Figure 2 - Labels on the QMB pump

2 TECHNICAL DATA

2.1 General

Overall dimensions	See Figures 3 to 5
Performance	
Backed by QDP dry pump	See Figures 6 to 9
Backed by 1 or 2-stage rotary pump	See Table 2
Mass	See Table 2
Continuous inlet pressure	
QMB250F and QMB500F	0 to 20 mbar, 0 to 2×10^3 Pa
QMB1200F	0 to 1 mbar, 0 to 100 Pa
Maximum outlet pressure (see Section 1.2.4)	1000 mbar, 1×10^5 Pa
Ambient operating temperature range	5 to 40 °C
Maximum operating humidity	90% RH
Protection degree (as defined by IEC 529)	IP44
Oil capacity	See Table 2
Recommended oil type	Fomblin YVAC 16/6 or Krytox 1514
Recommended grease (for QMB250F and QMB500F rear bearing)	Fomblin RT15

Note: A BOC Edwards Material Safety Data Sheet for the above oil is available on request.

2.2 Electrical data

Note: The motor is supplied configured for low-voltage operation (200-208 V at 50 Hz or 200-230 V at 60 Hz). To change the motor to high-voltage operation (380-415 V at 50 Hz or 460 V at 60 Hz) refer to Section 3.7.1.

Number of phases	3
Supply voltage	200-208 V/380-415 V at 50 Hz 200-230 V/460 V at 60 Hz
Voltage tolerance	±10%, except 208 and 415 V at 50 Hz which are +6% and -10%
Full load current rating	See Table 1

Supply voltage and frequency		200-208 V 50 Hz	200-208 V 60 Hz	230 V 60 Hz	380-415 V 50 Hz	460 V 60 Hz
QMB250F and QMB500F	Full load (A)	8.7	8.8	7.8	5.0	4.4
	Rating (kW)	2.2	2.2	2.2	2.2	2.2
QMB1200F	Full load (A)	16	16	14.2	8	8
	Rating (kW)	4	4	4	4	4

Table 1 - Full load current ratings

Motor protection thermistors

Type	Positive temperature coefficient
Reference temperature	160 °C
Compliant with	IEC 34-11 (BS4999 part 111)
Recommended control-unit	To comply with IEC 34-11 (BS4999 part 111)
Relay contact rating	Suitable for use with your contactor

Parameter	QMB250F	QMB500F	QMB1200F
Mass (kg)	65	78	157
Minimum cooling-water flow (l.h ⁻¹)	75	75	75
Oil capacity (l)			
Coupling-cover	1.5	1.5	2.4
Shaft-seal reservoir	0.125	0.125	0.125
Gear-case	-	-	1.25
Rotational speed (r.min ⁻¹)			
50 Hz supply	0 to 2900	0 to 2900	0 to 2900
60 Hz supply	0 to 3500	0 to 3500	0 to 3500
Ultimate pressure without gas-ballast, permanent gases	8 x 10 ⁻⁴ mbar 8 x 10 ⁻² Pa	8 x 10 ⁻⁴ mbar 8 x 10 ⁻² Pa	8 x 10 ⁻⁴ mbar 8 x 10 ⁻² Pa
Pressure differential across pump determined by the hydrokinetic drive	0 to 180 mbar 0 to 1.8 x 10 ⁴ Pa	0 to 110 mbar 0 to 1.1 x 10 ⁴ Pa	0 to 90 mbar 0 to 9 x 10 ³ Pa
Recommended backing-pump	QDP40 or QDP80	QDP40 or QDP80	QDP80 or DP180
Vacuum connections			
Inlet connection	ISO63 bolted	ISO100 bolted	ISO160 bolted
Outlet connection	ISO40 bolted	ISO63 bolted	ISO100 bolted
Cooling-water connections			
Inlet connection (BSP)	Hansen quick connect 3/8 inch male		
Outlet connection (BSP)	Hansen quick connect 3/8 inchfemale		
Noise data			
Continuous A-weighted sound pressure level (dB(A))	66	66	70

Table 2 - Technical data

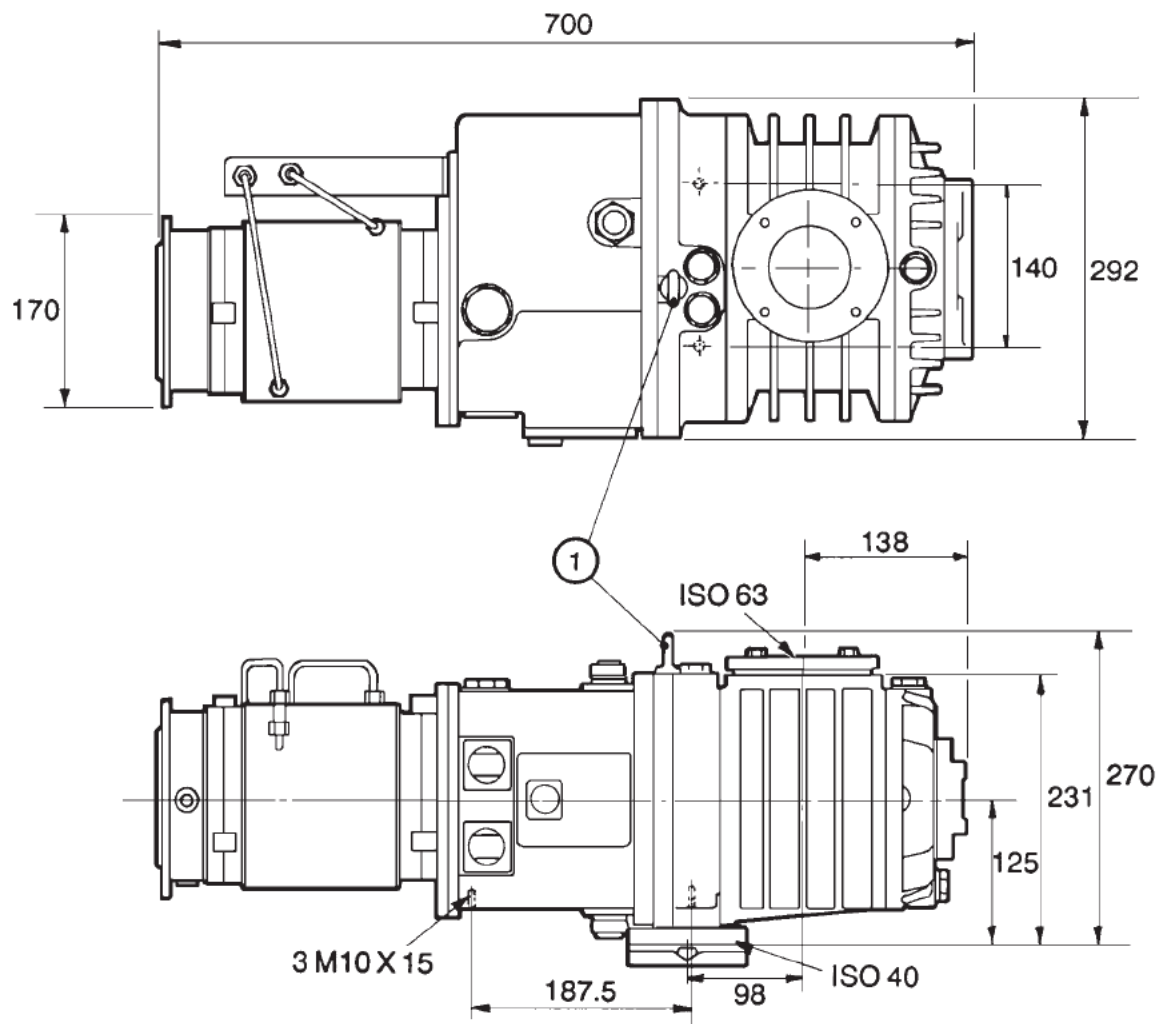

1. Lifting point

Figure 3 - QMB250F dimensions

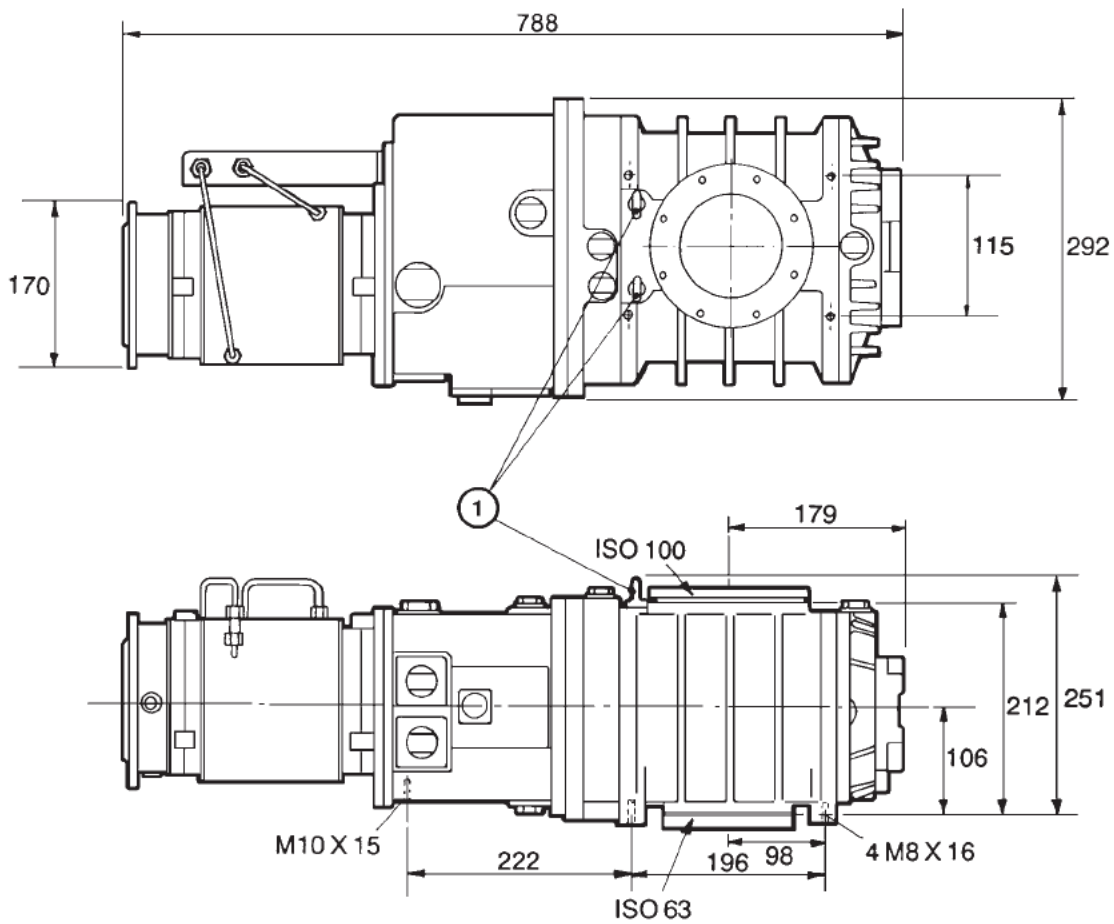

1. Lifting point

Figure 4 - QMB500F dimensions

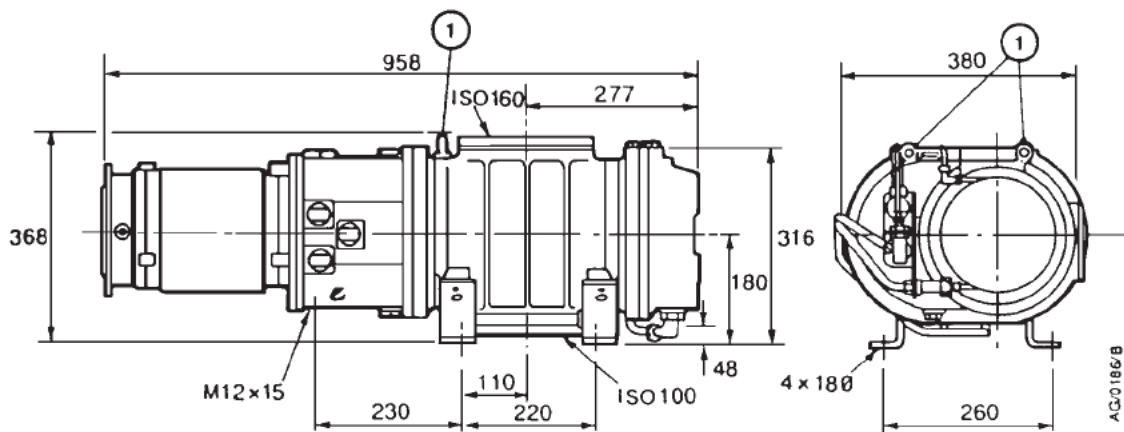

1. Lifting point

Figure 5 - QMB1200F dimensions

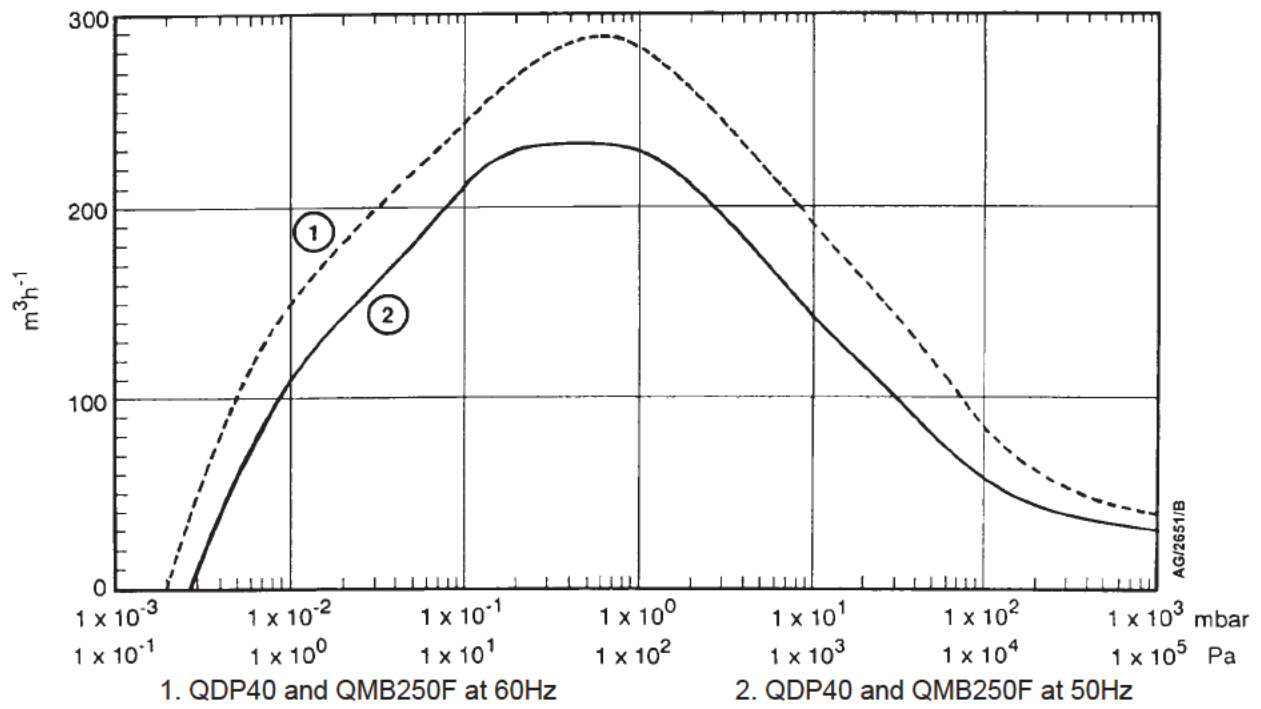

Figure 6 - Typical pumping speed for QDP40 and QMB250F pumping combinations

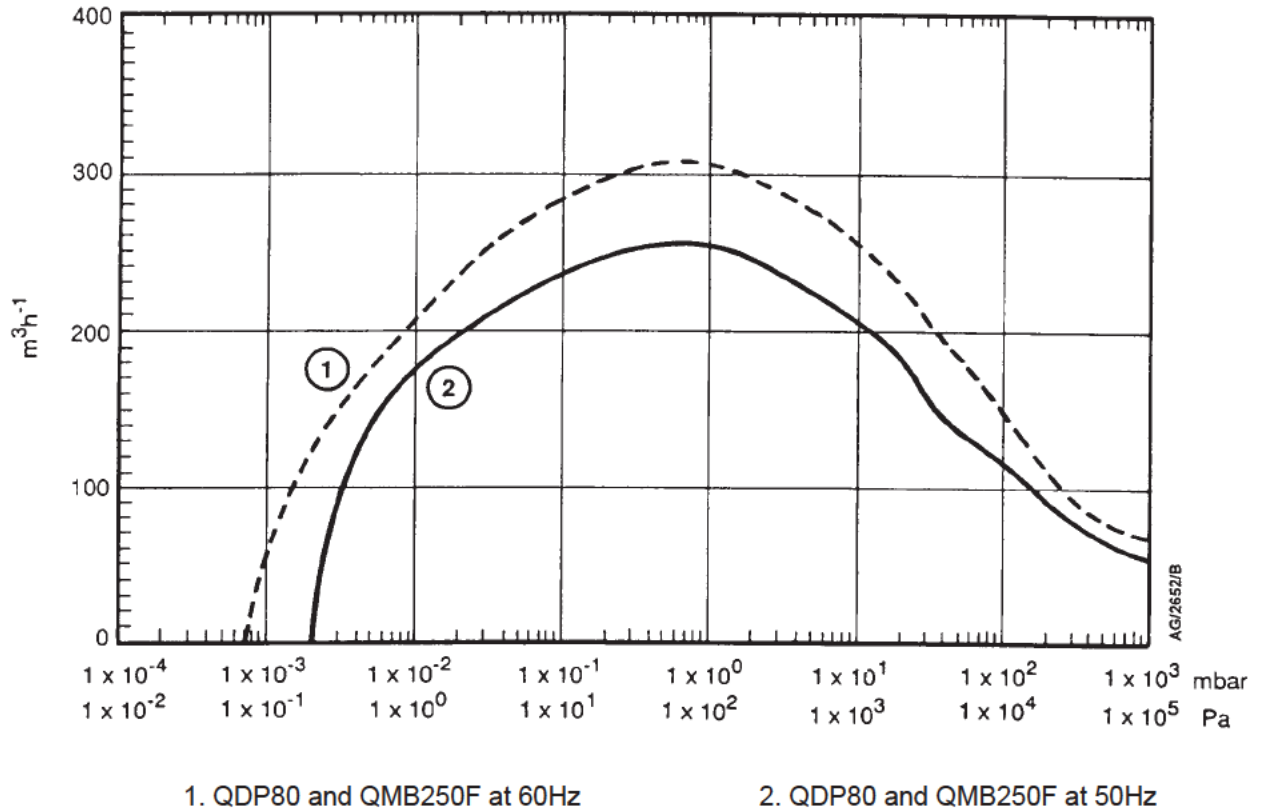
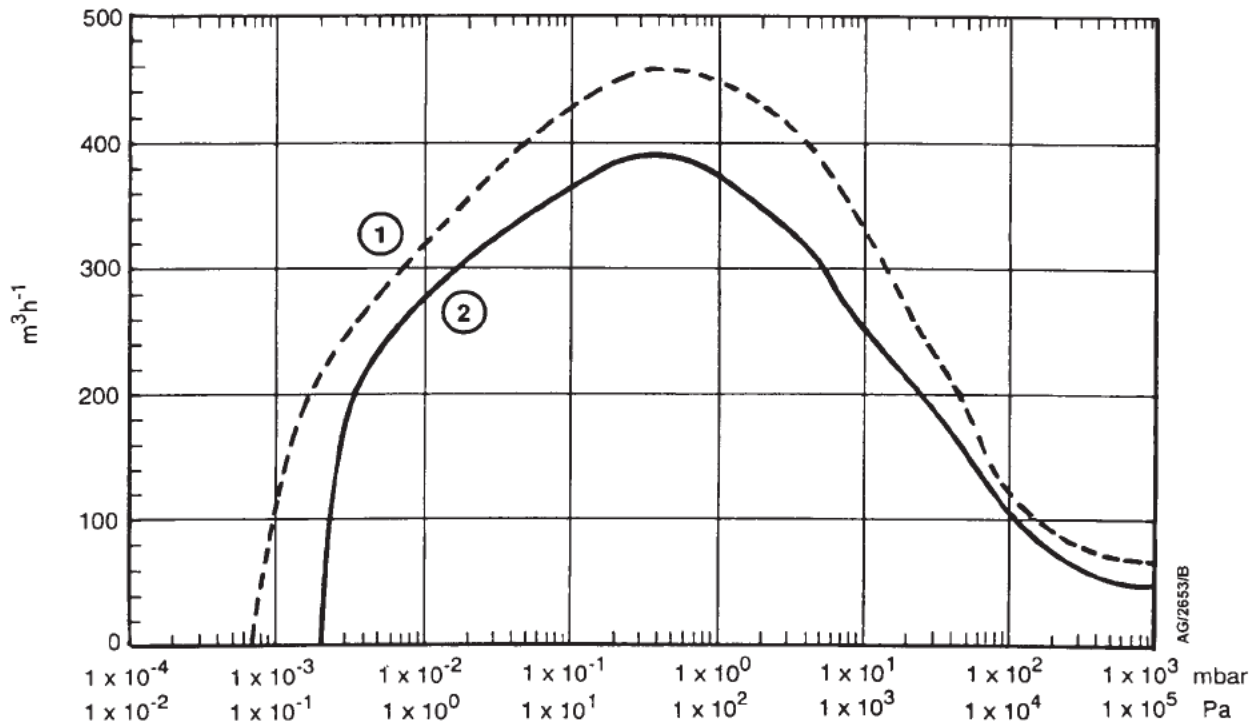

Figure 7 - Typical pumping speed for QDP80 and QMB250F pumping combinations



1. QDP80 and QMB500F at 60Hz

2. QDP80 and QMB500F at 50Hz

Figure 8 - Typical pumping speed for QDP80 and QMB500F pumping combinations

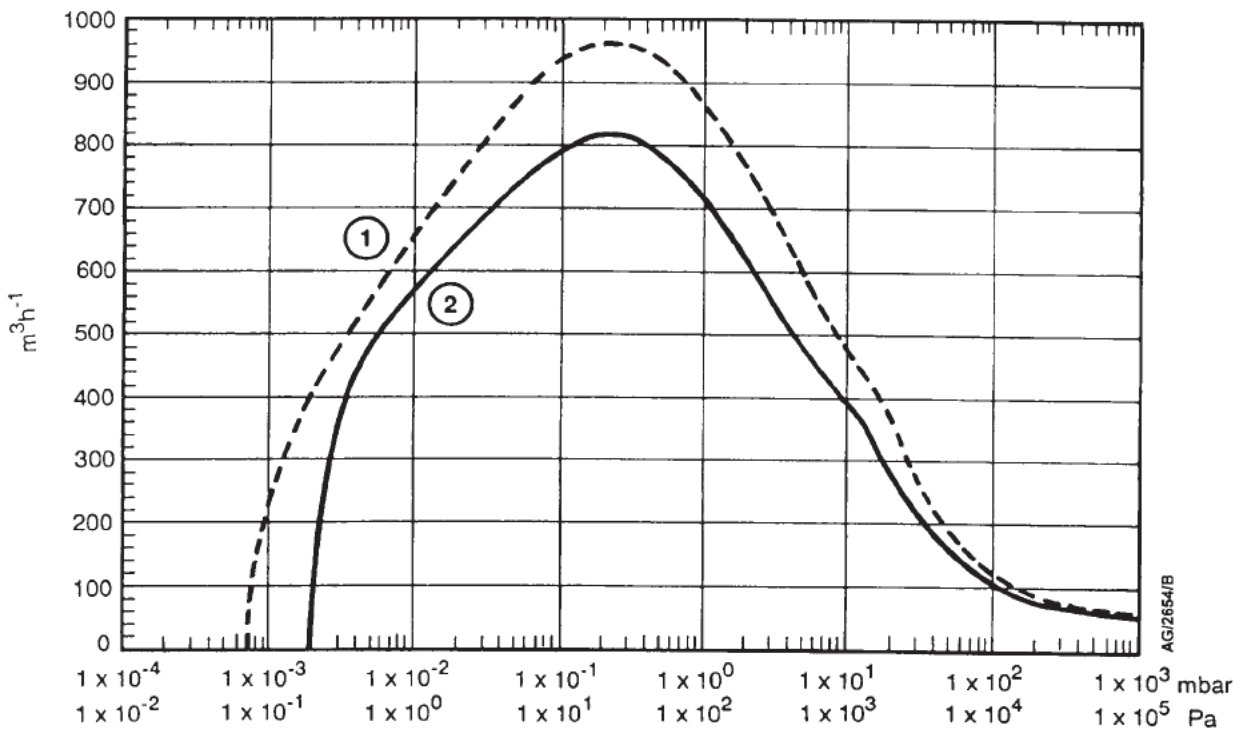

1. QDP80 and QMB1200F at 60Hz

2. QDP80 and QMB1200F at 50Hz

Figure 9 - Typical pumping speed for QDP80 and QMB1200F pumping combinations

3 INSTALLATION

3.1 Safety

WARNING

Obey the safety instructions given below and take note of appropriate precautions. If you do not, you can cause injury to people and damage to equipment.

- A suitably trained and supervised technician must install the pump.
- Ensure that the installation technician is familiar with the safety procedures which relate to the products handled by the pumping system. Wear the appropriate safety-clothing when you come into contact with contaminated components. Dismantle and clean contaminated components inside a fume-cupboard.
- If the QMB pump is to replace an existing pump, vent and purge the process system with nitrogen for 15 minutes before you start installation work.
- Check that all the required components are available and of the correct type before you start work.
- Disconnect the other components in the pumping system from the electrical supply so that they cannot be operated accidentally.
- Do not reuse any 'O' ring or 'O' ring assembly, and do not allow debris to get into the QMB pump during installation.
- Leak-test the system after installation work is complete to prevent leakage of hazardous substances out of the system and leakage of air into the system. Seal any leaks found to prevent leakage of dangerous substances out of the system, and leakage of air into the system.
- Do not remove the temporary cover or the blanking-plate from the QMB pump-inlet and pump-outlet until you are ready to connect the QMB pump to your vacuum system. Do not operate the QMB pump unless the inlet blanking-plate is fitted, or the QMB pump is connected to your vacuum system.
- Do not operate the QMB pump without a suitable backing pump: refer to Section 2.
- Wipe up any water or oil spilt during installation, so that people cannot slip over any spillages.
- Safely route and secure cables, hoses and pipes during installation, so that people cannot trip over them.
- Obey all local and national rules and safety regulations when you install the QMB pump.
- Consult BOC Edwards publication P300-20-000 (Vacuum Pump and Vacuum System Safety) before you pump hazardous materials. This publication is available on request: contact your supplier or BOC Edwards.

3.2 Unpack and inspect

WARNING

Use suitable lifting equipment to move the pump. Refer to Section 2 for the mass of the pump.

1. Place the pallet in a convenient position with a fork-lift truck or a pallet truck.
2. Remove all packing materials.
3. Use suitable lifting-gear to remove the pump from its pallet. Do not try to lift the pump by hand. Refer to Section 2 for the mass of the pump.
4. Remove all protective covers and inspect the pump. If the pump is damaged, notify your supplier and the carrier in writing within three days; state the Item Number of the pump together with your order number and your supplier's invoice number. Retain all packing materials for inspection. Do not use the pump if it is damaged.
5. If the pump is not to be used immediately, replace the protective covers. Store the pump in suitable conditions as described in Section 6.1.

3.3 Locate the pump

WARNING

Use suitable lifting equipment to move the pump. Refer to Section 2 for the mass of the pump.

Attach suitable lifting equipment to the lifting points on the pump (see Figures 3 to 5) to move the pump into its operating position. The pump must be mounted on a firm, level surface.

3.4 Fill the pump with oil

CAUTION

Ensure that the oil-levels in the pump are correct. If an oil-level is incorrect, pump performance may be affected and the pump may be damaged.

3.4.1 Coupling-cover

We recommend that the coupling-cover oil-level is maintained at the recommended oil-level shown in Figure 10, item 5; if the oil-level is above or below the recommended oil-level, the performance of the pump may be affected. Do not allow the coupling-cover oil-level to fall below the bottom of the reflector plate (Figure 10, item 4) or the pump may be damaged.

1. Remove the coupling-cover oil filler-plug (Figure 1, item 4).
2. Refer to Figure 10. Fill the coupling-cover with PFPE oil until the oil-level reaches the recommended oil-level (5) at the top of the reflector plate (4) in the coupling-cover sight-glass (3).
3. Refit the coupling-cover oil filler-plug.

3.4.2 Shaft-seal reservoir

WARNING

Ensure that the correct vented filler-plug is replaced in the shaft-seal reservoir. If you use a non-vented plug, the reservoir will be pressurised and the oil sight-glass may fracture.

We recommend that you fill the shaft-seal reservoir so that the oil-level is at the recommended oil-level, shown in Figure 10, item 2. You can operate the pump as long as the oil-level is above the bottom of the reflector plate. Do not allow the shaft-seal oil-level to fall below the bottom of the reflector plate or the pump may be damaged. You must use the same oil you used to fill the coupling-cover.

(Continued on page 14)

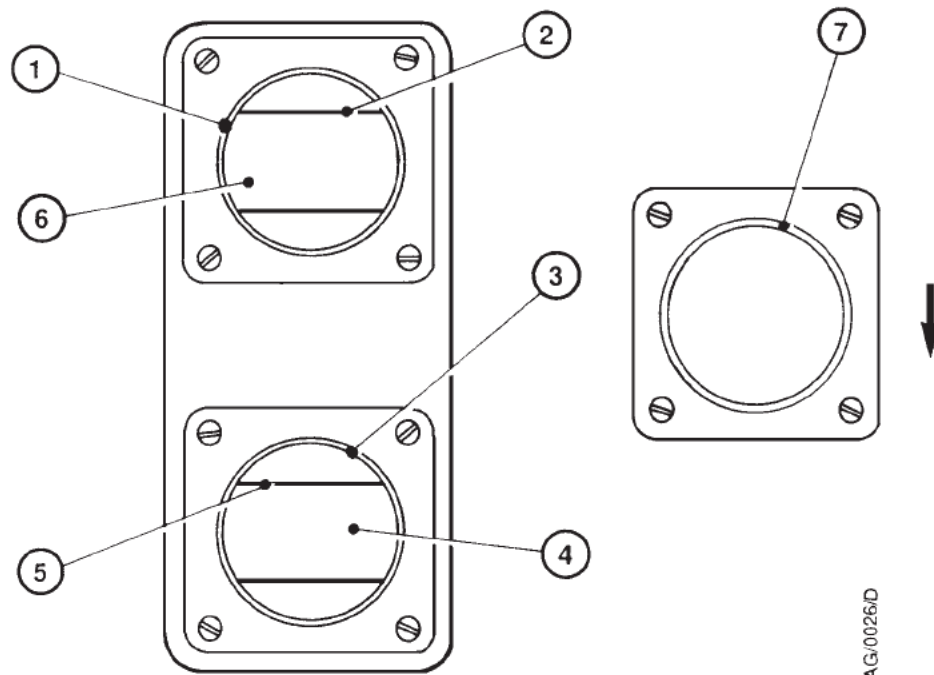

AG/0026/D

- | | |
|---|--|
| 1. Shaft-seal reservoir sight-glass | 5. Coupling-cover recommended oil-level |
| 2. Shaft-seal reservoir recommended oil-level | 6. Shaft-seal reflector plate |
| 3. Coupling-cover sight-glass | 7. Direction of rotation sight-glass (the arrow shows the correct direction of rotation) |
| 4. Coupling-cover reflector plate | |

Figure 10 - Sight-glasses

1. Remove the shaft-seal reservoir vented oil filler-plug (Figure 1, item 3).
2. Refer to Figure 10. Fill the shaft-seal reservoir with PFPE oil until the oil-level is at the recommended oil-level (2) at the top of the reflector plate (6).
3. Refit the vented oil filler-plug.

3.4.3 Gear-cover (QMB1200F only)

Use the following procedure to fill the gear-cover on the QMB1200F pump. You must fill the gear-cover with the same oil you used to fill the coupling-cover and shaft-seal reservoir.

1. Refer to Figure 1. Remove the oil filler-plug (16) on the top of the gear-cover; take care not to accidentally remove the plug from the external evacuation port (7).
2. Fill the gear-cover with oil until the oil-level is at the middle of the reflector plate in the gear-cover oil-level sight-glass (18).
3. Refit the oil filler-plug.

3.5 Cooling-water connections

WARNING

Do not turn on the cooling-water supply before you have finished all electrical installation. If you do, condensation may form inside the motor terminal-box and there may be a risk of electric shock.

Connect the cooling-water supply and return pipelines to the quick connectors on the cooling-water brackets on the pump (see Figure 1).

Refer to Section 2 for the minimum cooling-water flow rate required. Do not turn on the cooling-water supply yet.

3.6 Connect to your emergency stop system

The QMB pump must be connected to an emergency stop facility. The operation of the emergency stop function should immediately disconnect power from the QMB pump when the emergency stop control is operated. Returning the emergency stop control to its normal position should not result in power being re-applied to the QMB pump; a separate start or reset control should be used for this.

The excess temperature detected by the motor protection thermistors should also be connected to an emergency stop facility to cause the QMB pump to stop immediately, in the same way as the emergency stop function.

Refer to Figure 11 and to Section 3.7 for more information about the electrical connections.

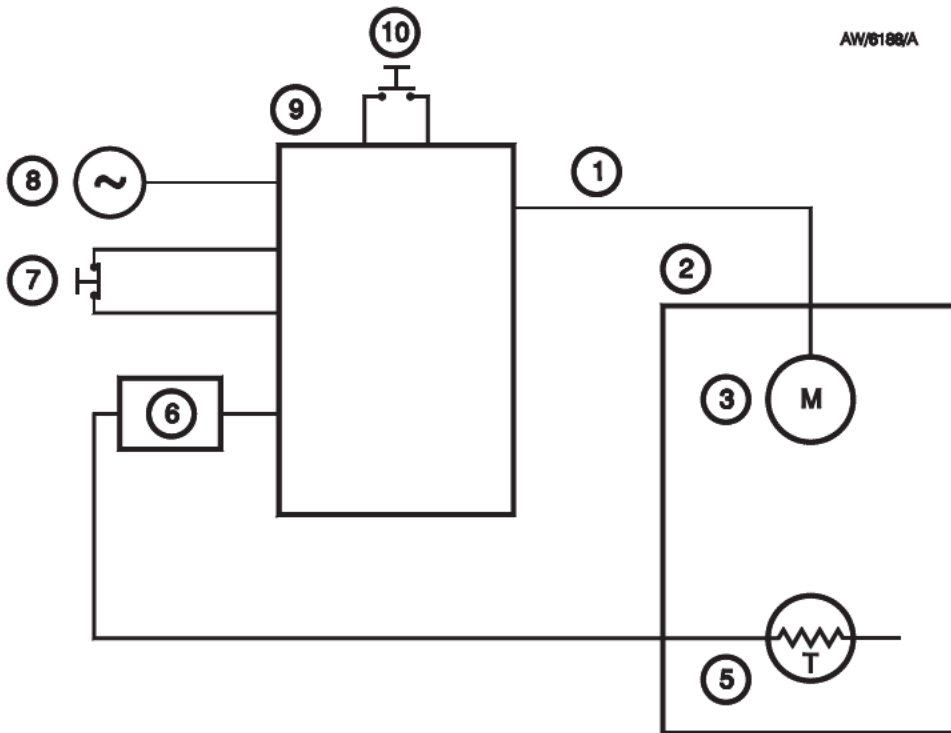

1. Electrical supply to QMB pump-motor
2. QMB pump
3. QMB pump-motor
4. Not used
5. Motor-protection thermistors
6. Thermistor interface
7. Emergency stop control
8. External electrical supply
9. Emergency stop system
10. Reset/start controls

Figure 11 - Schematic diagram of the emergency stop system

3.7 Electrical connections

WARNING

Use suitable cable-glands so that the seals of the electrical supply and thermistor cable entries into the motor terminal-box meet the requirements of IP44 (or higher), as defined by IEC 529. If you do not, condensation may form inside the terminal-box and there may be a risk of electric shock.

3.7.1 High and low-voltage operation

The universal motors are supplied configured for 'low-voltage' operation (200-208 V at 50 Hz or 200-230 V at 60 Hz). Figures 12 and 14 show the low voltage configurations for the QMB250/500F and QMB1200F pumps.

To change the QMB250/500F pump-motor to 'high-voltage' operation (380-415 V at 50 Hz or 460 V at 60 Hz), remove the pump-motor terminal-box cover, then remove the three links from the U, V and W terminals. Link the U1, V1 and W1 terminals as shown in Figure 13.

To change the QMB1200F pump-motor to 'high-voltage' operation (380-415 V at 50 Hz or 460 V at 60 Hz), remove the pump-motor terminal-box cover, then remove the wires from the U1, V1 and W1 terminals. Reconnect the wires to the terminals as shown in Figure 15.

3.7.2 Motor connections

CAUTION

The motor must be correctly configured and you must make the correct electrical connections for your electrical supply. If you do not, you can damage the motor.

Connect the motor to the electrical supply as described below. Connect the supply through a contactor which has overload-protection, or use a controller which incorporates a contactor. You must use a contactor which has a manual reset control. If you do not, the pump could automatically restart after an electrical overload or an electrical supply failure.

1. Remove the motor terminal-box cover.
2. Check your electrical supply voltage and frequency. If necessary, configure the motor to operate with your supply voltage (see Section 3.7.1).
3. Remove the plug from the cable entry-hole you will use for the electrical supply cable. Choose the most suitable entry-hole for your application.
4. Fit a suitable 20 mm cable-gland to the hole. If your cable is too large to pass through a 20 mm cable-gland, fit a 20 mm to 25 mm female thread-adaptor to the cable entry-hole, and fit a 25 mm cable-gland to the adaptor. The cable-gland (and adaptor, if fitted) must provide a protective seal to IP44 (or higher), as defined by IEC 529.

5. Pass the supply cable through the cable-gland and connect the wires of the electrical supply cable to the appropriate terminals (see Figures 12 to 15).
6. Tighten the cable-gland.

3.7.3 Motor-protection thermistors

Connect the output of the motor-protection thermistors to your control equipment to switch off the pump if the motor is too hot. Refer to Section 2 for the specification of a suitable control-unit. To connect the thermistors output:

1. Remove the plug from the other cable entry-hole.
2. Fit a suitable 20 mm cable-gland to the entry-hole. The cable-gland must be a protective seal to IP44 (or higher) as defined by IEC 529.
3. Pass the thermistor cable through the cable-gland.
4. Refer to Figures 12 to 15. Connect the two wires of the thermistor cable to the thermistor terminals (T1 and T2). Connect the other ends of the wires to your control equipment.
5. Tighten the cable-gland, then refit the motor terminal-box cover.

3.8 Check the pump rotation

WARNING

Blank the inlet or connect the pump to the vacuum system before you check the direction of pump rotation. If you do not, there is danger of objects being trapped in the rotating rotors.

It is possible for the three-phase electrical supply to the motor to be phased incorrectly. If the supply is phased incorrectly, the rotors will rotate slowly in the reverse direction or remain stationary. Look through the direction of rotation sight-glass in the coupling-cover (Figure 1, item 11) to check the direction of rotation of the motor-coupling. An enlarged view of the sight-glass is shown in Figure 10. The correct direction of rotation is indicated by an arrow. Check the direction of rotation as described below.

1. Check that the pump is connected to the vacuum system or that the inlet is blanked off.
2. Connect the backing-pump and switch the backing-pump on.
3. Watch the motor-coupling in the sight-glass (Figure 10, item 7) and switch on the QMB pump for two or three seconds.
4. Check that the direction of rotation of the coupling is the same as that indicated by the rotation arrow on the motor and shown in Figure 10.
5. If the direction of rotation of the coupling is incorrect, switch off the backing-pump and isolate the QMB pump from the electrical supply. Reverse any two of the phase-wires in the motor terminal-box.
6. Repeat the check to ensure that the direction of rotation is now correct.

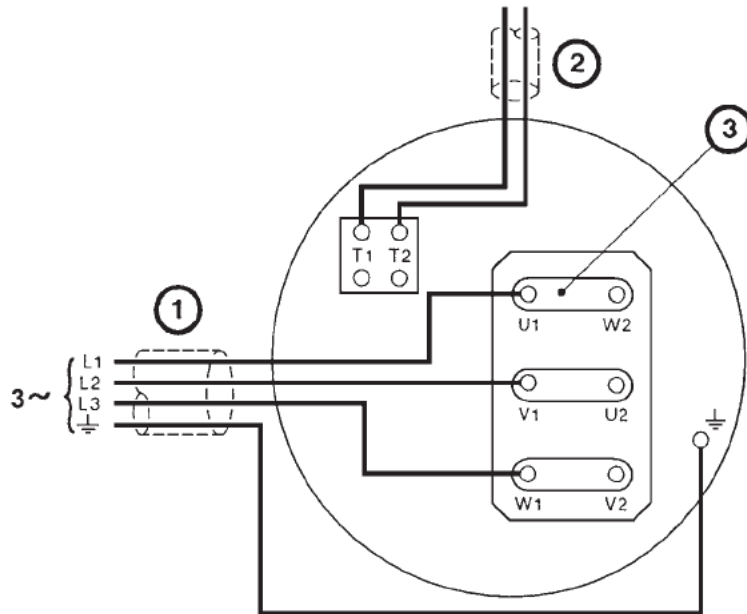

AW/1897/A

1. Electrical supply cable
2. Thermistors cable
3. Links

Figure 12 - QMB250/500F low-voltage configuration

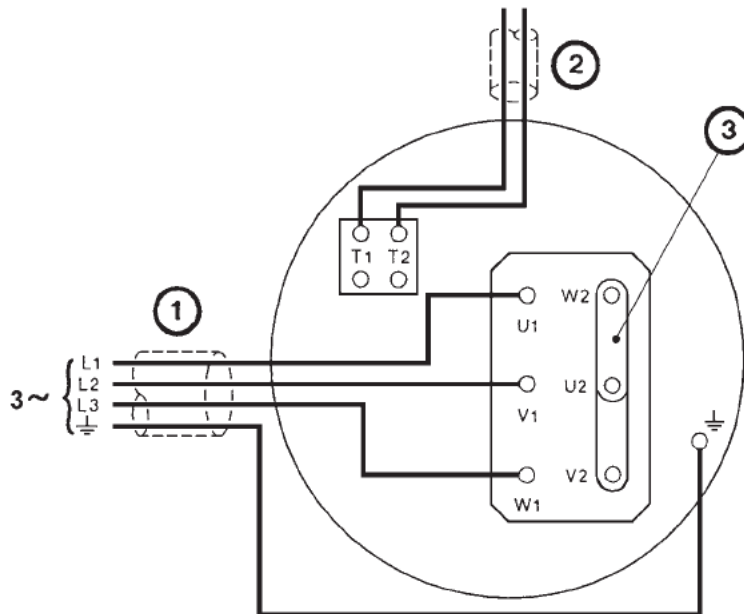

AW/1898/A

1. Electrical supply cable
2. Thermistors cable
3. Links

Figure 13 - QMB250/500F high-voltage configuration

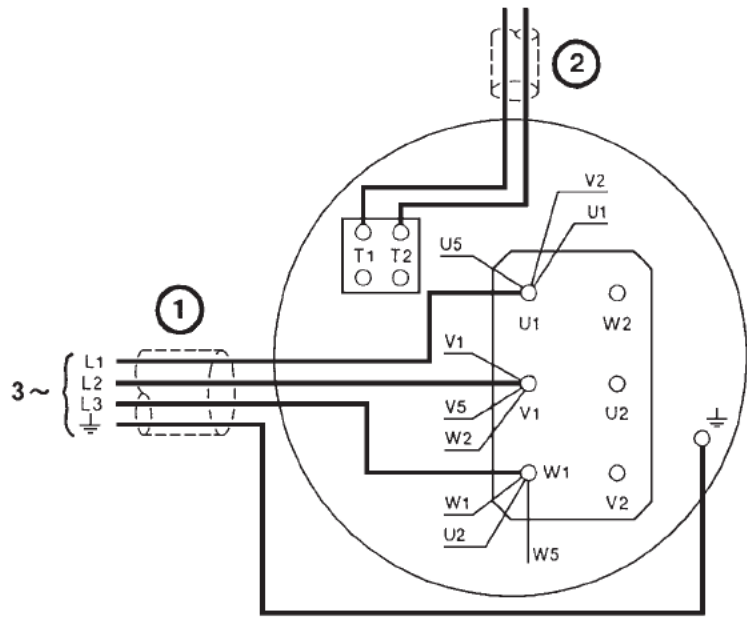

AW/1895/A

- 1. Electrical supply cable
- 2. Thermistors cable

Figure 14 - QMB1200F low-voltage configuration

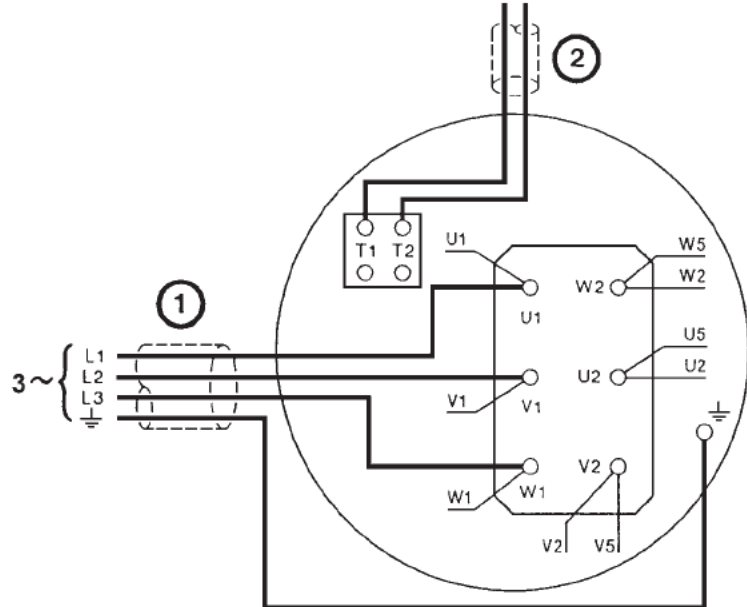

AW/1900/A

- 1. Electrical supply cable
- 2. Thermistors cable

Figure 15 - QMB1200F high-voltage configuration

3.9 Connect the pump-inlet and outlet

Consider the following points when you connect your pump:

- You must use a suitable backing pump: refer to Section 2.
- For optimum pumping speeds, ensure that the pipeline connected to the pump-inlet is as short as possible and has a bore size not less than the inlet-port diameter.
- On very dusty applications, use a low-impedance inlet-filter to minimise abrasion in the pump. A range of inlet-filters is available; if necessary, contact your supplier or BOC Edwards for advice.
- Adequately support vacuum pipelines to stop the transmission of stress to the pipeline joints.
- If necessary, incorporate flexible pipelines in your system pipelines to reduce the transmission of vibration and to prevent loading of coupling-joints. If you use flexible pipelines, you must ensure that you use flexible pipelines which have a maximum pressure rating which is greater than the highest pressure that can be generated in your system.
- You must be able to isolate the pump-inlet and exhaust from the atmosphere and from your vacuum system if you have used corrosive chemicals in the pump.
- You can incorporate a suitable control system so that the QMB pump is only switched on if the inlet pressure is below the maximum inlet pressure.

Before you connect the QMB pump to your vacuum system, remove the blanking-plates fitted to the pump-inlet and outlet. Retain the nuts, bolts and washers for future use. Retain the blanking-plates for future use as temporary covers, for uncontaminated pumps only.

Ensure that debris does not get into the pump when you install it. If the pump is to replace a pump in an existing system, purge the existing pump with nitrogen for 15 minutes before you disconnect it.

Use standard ISO flanges to connect the pump-inlet and outlet. Use a BOC Edwards trapped 'O' ring to seal the pump-inlet connection and use a BOC Edwards trapped 'O' ring or (on the QMB250F only) a BOC Edwards Co-Seal to seal the pump-outlet connection.

3.10 External evacuation of coupling-cover (optional)

You can use an external pump to evacuate the coupling-cover. A description of the connections required is beyond the scope of this manual. Contact your supplier or your nearest BOC Edwards company for advice if you wish to use this facility.

4 OPERATION

4.1 Operational safety

WARNING

Do not touch any part of the pump when it is switched on. Surfaces of the pump are very hot, especially at high inlet pressures, and can cause injury to people and damage to equipment.

If you operate the QMB250F or QMB500F pump in an area with poor ventilation, the temperature of the coupling-cover can reach 100 °C and above. Take all necessary precautions to avoid accidental contact with the coupling-cover; if necessary, use a pump enclosure or fit a guard to the pump.

If you operate the QMB1200F pump with the inlet pressure higher than 1 mbar (100 Pa) for a long period, the stator and the coupling-cover will reach very high temperatures. Take all necessary precautions to avoid accidental contact with the stator and the coupling-cover; if necessary, use a pump enclosure or fit a guard to the pump.

4.2 Start-up

Start-up the pump as described in the procedure below. This procedure assumes that the pump and the vacuum system are at atmospheric pressure.

1. Check that the pump oil-levels are correct (see Section 3.4).
2. Switch on the cooling-water supply and check that there is an adequate flow of cooling-water.
3. Close all valves to atmospheric pressure and ensure that all other openings are closed.
4. Switch on the backing pump and open the backing valve (if fitted).
5. When the inlet pressure is below the maximum inlet pressure for the pump, switch on the pump.
6. Slowly open the pump-inlet isolation-valve (if fitted).
7. Allow the pump to operate for approximately fifteen minutes to achieve normal operating temperature.
8. Inspect the cooling-water connections and pipes and check that there are no leaks. If there are any leaks, shut down the pumping system (refer to Section 4.3) and seal the leaks.

4.3 Shut-down

1. Close the pump-inlet isolation-valve (if fitted).
2. Switch off the mechanical booster pump.
3. Open the backing-pump air-admittance valve (if fitted) and switch off the backing-pump.
4. Turn off the cooling-water supply.

5 MAINTENANCE

5.1 Safety

WARNING

Obey the safety instructions given below and take note of appropriate precautions. If you do not, you can cause injury to people and damage to equipment.

- A suitably trained and supervised technician must maintain the pump.
- Ensure that the maintenance technician is familiar with the safety procedures which relate to the products pumped. Wear the appropriate safety-clothing when you come into contact with contaminated components. Dismantle and clean contaminated components inside a fume-cupboard.
- Allow the pump to cool to a safe temperature before you start maintenance work
- Vent and purge the pumping system with nitrogen before you start any maintenance work.
- Check that all the required parts are available and of the correct type before you start work.
- Isolate the pump and other components from the electrical supply so that they cannot be operated accidentally.
- Recheck the pump rotation direction if the electrical supply has been disconnected.
- Do not reuse any 'O' ring or 'O' ring assembly, and do not allow debris to get into the QMB pump during maintenance.
- Dispose of components safely (see Section 6.2).
- Take care to protect sealing-faces from damage.
- Do not touch or inhale the thermal breakdown products of fluorinated materials which may be present if the pump has been overheated to 260 °C and above. These breakdown products are very dangerous. Fluorinated materials in the pump may include oils, greases and seals. The pump may have overheated if it was misused, if it malfunctioned or if it was in a fire. BOC Edwards Material Safety Data Sheets for fluorinated materials used in the pump are available on request: contact your supplier or BOC Edwards.
- Leak-test the system after maintenance work is complete if you have connected or disconnected any vacuum joints. Seal any leaks found to prevent leakage of dangerous substances out of the system, and leakage of air into the system.
- Fit suitable blanking-plates to the pump-inlet and outlet as soon as you have disconnected the QMB pump from your vacuum system. Do not operate the pump unless the inlet blanking-plate is fitted, or the pump is connected to your vacuum system.
- Do not operate the QMB pump without a suitable backing pump: refer to Section 2.
- Wipe up any water or oil spilt during maintenance, so that people cannot slip over any spillages.
- Safely route and secure all cables, hoses and pipes during maintenance, so that people cannot trip over them.

5.2 Maintenance plan

The plan shown in Table 3 details the maintenance operations necessary to maintain QMB pumps in normal use. Instructions for each operation are given in the section shown.

More frequent maintenance may be required if the pump has been used to pump corrosive or abrasive gases and vapours. If necessary, adjust the maintenance plan according to your experience.

Operation	Frequency	Refer to Section
Check the oil-levels	3 monthly	5.3
Inspect the pump connections	Monthly	5.4
Lubricate the rear-bearing *	12 monthly	5.5
Change the pump oil	As required	5.6

* QMB250F and QMB500F only

Table 3 - Maintenance plan

5.3 Check the oil-levels

CAUTION

Ensure that the oil-levels in the pump are correct. If an oil-level is incorrect, pump performance may be affected and the pump may be damaged.

Note: If there is a loss of oil from the shaft-seal reservoir, the shaft-seal may have failed. You cannot replace the shaft-seal ; contact your supplier or a BOC Edwards Service Centre for advice.

Use the following procedure to check the oil-levels in the sight-glasses. Refer to Figure 1 for the location of the filler-plugs and sight-glasses. During normal operation, the coupling-cover sight-glass (Figure 10, item 2) may appear empty or show a froth because the oil is in circulation around the coupling.

1. Refer to Figure 10. Check the shaft-seal oil-level. If the oil-level is below the bottom of the reflector plate (6), refer to Section 3.4 and refill the shaft-seal reservoir.
2. Check the coupling-cover oil-level. If the oil-level is below the top of the reflector plate, refer to Section 3.4 and refill the coupling-cover reservoir.
3. On the QMB1200F only, check the gear-cover oil-level in the gear-cover sight-glass (Figure 1, item 18). If the oil-level is below the middle of the reflector plate, refer to Section 3.4 and refill the gear-cover.

5.4 Inspect the pump connections

1. Check that the cooling-water connections are secure. Tighten any connections that are loose.
2. Inspect the cooling-water pipelines and connections and check that they are not corroded or damaged and do not leak. Replace any pipelines and connections which are corroded or damaged or leak.
3. Check that the electrical connections are secure. Tighten any connections that are loose.
4. Check the electrical supply cables for damage. Replace any cable which is damaged.
5. Check that all the vacuum connections are secure. Tighten any connections that are loose.
6. Inspect all the vacuum pipelines and connections and check that they are not corroded or damaged. Replace any pipelines and connections which are corroded or damaged.

5.5 Lubricate the rear-bearing (QMB250F and QMB500F only)

1. Switch off the pump and isolate it from the electrical supply. Vent the pump to atmospheric pressure.
2. Refer to Figure 16. Remove the four plastic cover-caps (8) from the end-cover (6).
3. Undo and remove the socket-head screws (7) located under the four plastic cover-caps.
4. Remove the end-cover (6) and 'O' ring (5). Dispose of the 'O' ring safely.
5. Note the exact location of the shims (4) and spacers (3) inside the end-cover (6). Clean off all visible grease from the end-cover; take care not to misplace or damage the shims and spacers.
6. Use a clean, lint-free cloth or a plastic or wooden spatula to remove all visible grease from both bearings (2).
7. Fill the visible side of each bearing (2) with clean grease, then lightly force the grease into the bearings.
8. Apply a light wipe of high-vacuum grease to the new 'O' ring (5) and fit it into the groove in the end-cover (6).
9. Check that the shims (4) and spacers (3) are correctly located in the end-cover (6).
10. Fit the end-cover (6) and secure with the four socket-head screws (7). Tighten the screws evenly and refit the plastic cover-caps (8).

5.6 Change the pump oil

WARNING

Ensure that the correct vented filler-plug is replaced in the shaft-seal reservoir. If you use a non-vented plug, the reservoir will be pressurised and the oil sight glass may fracture.

CAUTION

Ensure that the oil-levels in the pump are correct. If an oil-level is incorrect, pump performance may be affected and the pump may be damaged.

Replace the pump oil as described below. Refer to Figure 1 for the location of the oil-filler and drain-plugs.

1. Switch off the pump and allow it to cool.
2. Remove the coupling-cover oil filler-plug (4).
3. Remove the coupling-cover oil drain-plug (10) from the underside of the coupling-cover and allow the oil to drain into a suitable container.
4. Remove the shaft-seal vented oil filler-plug (3). Use a suitable pump to suck the oil out of the shaft-seal reservoir.
5. Refit the coupling-cover oil drain-plug (10).
6. Refer to Section 3.4 and fill the coupling-cover and shaft-seal reservoir with oil.
7. Refit the coupling-cover oil filler-plug (4) and the shaft-seal vented oil filler-plug (3).
8. On QMB1200F pumps only:
 - Remove the filler-plug on the gear-cover; take care not to accidentally remove the plug from the external evacuation port (7).
 - Remove the drain-plug from the underside of the gear-cover and allow the oil to drain into a suitable container.
 - Refit the drain-plug and refer to Section 3.4 to refill the gear-cover with oil.

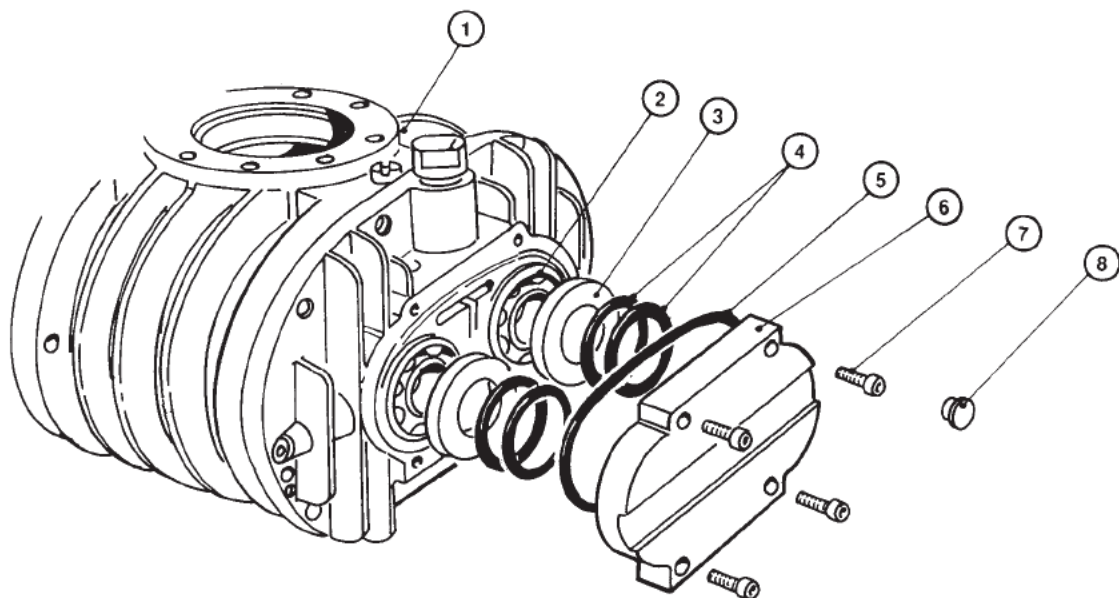

AG2669/A

- | | |
|--------------|----------------------|
| 1. Pump-body | 5. 'O' ring |
| 2. Bearing | 6. End-cover |
| 3. Spacer | 7. Socket-head screw |
| 4. Shims | 8. Cover-cap |

Figure 16 - Lubricate the rear bearing (QMB250F and QMB500F only)

6 STORAGE AND DISPOSAL

6.1 Storage

Use the procedure below to store the pump.

1. Shut-down the pump as described in Section 4.
2. Isolate the pump from the electrical supply and disconnect it from the vacuum system.
3. Clean the pump and change the oil as described in Section 5.
4. Place protective covers over the inlet and outlet-flanges.
5. Store the pump in cool, dry conditions until required for use. When required, prepare and install the pump as described in Section 3.

6.2 Disposal

Dispose of the pump and any components safely in accordance with all local and national safety and environmental requirements.

Take particular care with components which have been contaminated with dangerous process substances.

(This page deliberately left blank)