

NOTICE: This document contains references to Varian. Please note that Varian, Inc. is now part of Agilent Technologies. For more information, go to www.agilent.com/chem.



TriScroll™ 620 Series Dry Scroll Vacuum Pump

*INSTALLATION AND
OPERATION MANUAL*

Manual No. 699904343
Revision E
April 2007

TriScroll™ 620 Dry Scroll Vacuum Pump



TriScroll is a trademark of Varian, Inc.

Contents

Declaration of Conformity

Warrantyvi

Warranty Replacement and Adjustmentvi

Instructions for Use 1

General Information 1

Storage 1

Installation Requirements 2

Operation 2

Start up Procedure 2

Shutdown Procedure 2

Maintenance 2

Technical Information 3

Unpacking and Inspection 5

Installation 6

Safety 6

Startup 6

Electrical Connections 7

Single Phase Motor Connection 7

Mechanical Connections 7

Pump Location 7

Rotation of the Pump Inlet

with Respect to the Motor Frame 8

Pump Inlet 8

Pump Exhaust 8

Optional Isolation Valve 8

Gas Ballast 9

Bearing Purge 9

Purge Kit 9

Troubleshooting 10

Maintenance 11

General Information 11

Related TriScroll Manuals 11

Maintenance and Tooling Kits 11

Factory Service Options 12

Accessories 12

Contacting Varian 12

Request for Return Health and Safety Certification

List of Figures

Figure	Caption	Page
1	Interface Drawing with Dimensions	4
2	Pumping Speed Curves	4
3	TriScroll 620 Vacuum Pump	5
4	Single Phase Motor Electrical Connections . .	7
5	Isolation Valve Location	8

List of Tables

Table	Title	Page
1	Specifications	3
2	Full Load Motor Currents, Amps	7
3	VPI Valve Installation Data	9
4	Troubleshooting Chart	10
5	Other Related Manuals	11
6	Maintenance and Tooling Kits	11
7	Factory Service Options	12
8	Accessories	12

This page intentionally left blank.

Instructions for Use

General Information

This equipment is designed for use by professionals. The user should read this instruction manual and any other additional information supplied by Varian before operating the equipment. Varian will not be held responsible for any events that occur due to non-compliance with these instructions, improper use by untrained persons, non-authorized interference with the equipment, or any action contrary to that provided for by specific national standards.

The TriScroll™ 620 is a dry scroll vacuum pump specifically optimized for helium leak detection equipment. This pump is suitable for pumping air or inert gases. The pump is not intended to pump toxic, corrosive, explosive, or particulate-forming gases.

The following paragraphs contain all the information necessary to guarantee the safety of the operator when using the equipment. Detailed information is supplied in "Technical Information" on page 3.

This manual uses the following standard safety protocol:

WARNING



The warning messages are for attracting the attention of the operator to a particular procedure or practice which, if not followed correctly, could lead to serious injury.

CAUTION



The caution messages are displayed before procedures, which if not followed, could cause damage to the equipment.

NOTE



The notes contain important information taken from the text.

Storage

When transporting and storing the pump, the following environmental requirements should not be exceeded:

Temperature: -20 °C to 60 °C (-4 °F to 140 °F)
Relative humidity: 0 to 95% (non-condensing)

Preparation for Installation

The pump is supplied in a special protective packing. If this shows signs of damage, which may have occurred during transport, contact your local sales office.

Total weight of the packing, including the pump, is approximately 40 kg (87 lbs).

WARNING



When unpacking the pump, be sure not to drop it, and avoid any kind of sudden impact or shock vibration to it.

WARNING



The TriScroll 620 weighs 32 kg (70 lbs). To avoid injury, use proper lifting techniques when moving the pump.

NOTE



Normal exposure to the environment cannot damage the pump. Nevertheless, it is advisable to keep the pump inlet closed until the pump is installed in the system.

Installation Requirements

Do not install or use the pump in an environment exposed to atmospheric agents (rain, snow, ice), dust, aggressive gases, or in explosive environments or those with a high fire risk.

During operation, the following environmental conditions must be respected:

Temperature: +5 °C to +40 °C (41 °F to 104 °F)
Relative humidity: 0 to 95% (non-condensing)

CAUTION



As supplied from the factory, the pump is configured for low voltage. Verify that the configuration matches the supply voltage.

If voltage changeover is required, configure the voltage as described in "Electrical Connections" on page 7.

Operation

In order to reach ultimate vacuum, the pump must be left running for about an hour with the inlet sealed.

Unlike conventional oil-sealed pumps, Varian's dry scroll pumps do not have fluid to cleanse them of accumulated dust and debris. Run the pump periodically at atmosphere for a minute or two to flush out the pump. Flush the pump regularly and adjust this schedule according to your specific conditions.

WARNING



During operation the outer surface of the motor housing can become hot. Avoid touching the motor housing during pump operation.

Start up Procedure

1. Be sure that the vacuum system isolation valve is closed.
2. Turn on power to the pump.
3. Open the isolation valve.

Shutdown Procedure

1. Close the vacuum system isolation valve. This prevents debris in pump from being transported into the vacuum system.
2. Turn off power to the pump.

WARNING



The pump is designed for operation with neutral or noncorrosive fluids. It is absolutely forbidden to use it with potentially explosive, inflammable or poisonous substances.

Maintenance

Personnel responsible for pump operation and maintenance must be well-trained and aware of the accident prevention rules.

WARNING



- Death may result from contact with high voltages. Always take extreme care and observe the accident prevention regulations in force.*
- When the machine is powered up, be careful of moving parts and high voltages.*
- If you have to perform maintenance on the pump after a considerable time in operation, allow the pump to cool as the temperature of the outer surface may be in excess of 55 °C (131 °F).*
- Always disconnect your power supply to the pump before beginning maintenance work.*

NOTE



Before returning the pump to the factory for repair, the "Health and Safety" sheet attached to this instruction manual must be completed and sent to the local sales office. A copy of the sheet must be inserted in the pump package before shipping.

If a pump is to be discarded, it must be disposed of in accordance with specific national and local standards.

Technical Information

Table 1 Specifications

Model	TriScroll™ 620 Dry Scroll Vacuum Pump
Interface dimensions	See Figure 1
Peak pumping speed	50 Hz: 420 l/m, 25.2 m ³ /hr (14.8 cfm) 60 Hz: 500 l/m, 30 m ³ /hr (17.7 cfm)
Media	Clean air. No toxic, corrosive, explosive or particulate forming gases
Ultimate pressure (Torr)	7.0 x 10 ⁻³ Torr (9.3 x 10 ⁻³ mbar)
Maximum inlet pressure	1.0 atmosphere (0 psig)
Maximum outlet pressure	1.1 atmosphere (1.5 psig)
Inlet connection	NW40
Exhaust connection	Female 3/8" National Pipe Thread (NW25 adapter provided)
Gas ballast	Female 1/4" National Pipe Thread (40 Micron sintered filter provided)
Ambient operating temperature	5 °C to 40 °C (41 °F to 104 °F)
Storage temperature	-20 °C to 60 °C (-4 °F to 140 °F)
Motor rating	1.0 HP (0.76 kW)
Operating voltages	Single phase models: □ 50-60 Hz/100-115:200-230 VAC
Motor full load currents	See Table 2 on page 7
Motor thermal protection	Type U automatic
Operating speed	60 Hz: 1725 RPM, 50 Hz: 1425 RPM
Cooling system	Air-cooled
Weight	Pump only: 32 kg (70 lbs) Shipping weight: 40 kg (87 lbs)
Noise level (per ISO 11201)	68 dB(A)
Vibration level at inlet (per ISO 10816-1)	6.3 mm/sec

TriScroll 620 Series Vacuum Pump

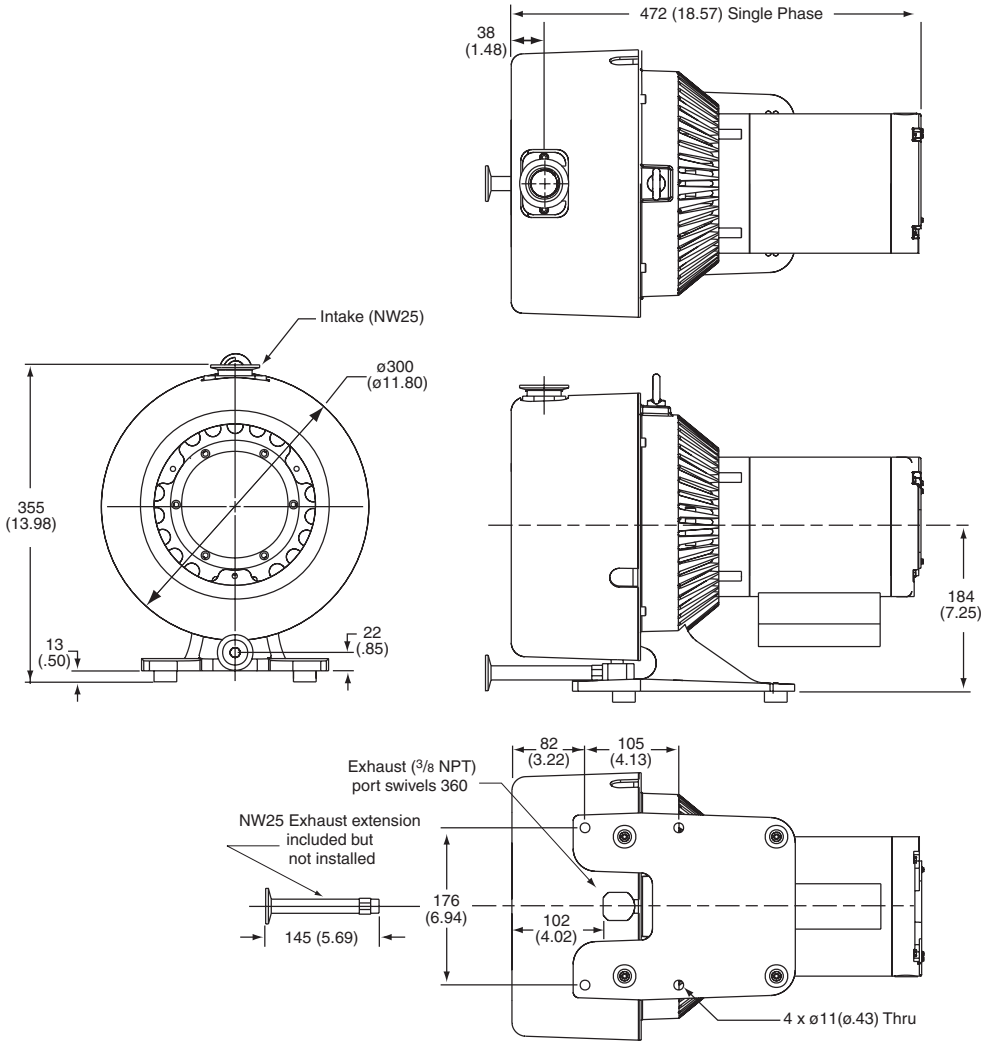

Figure 1 Interface Drawing with Dimensions

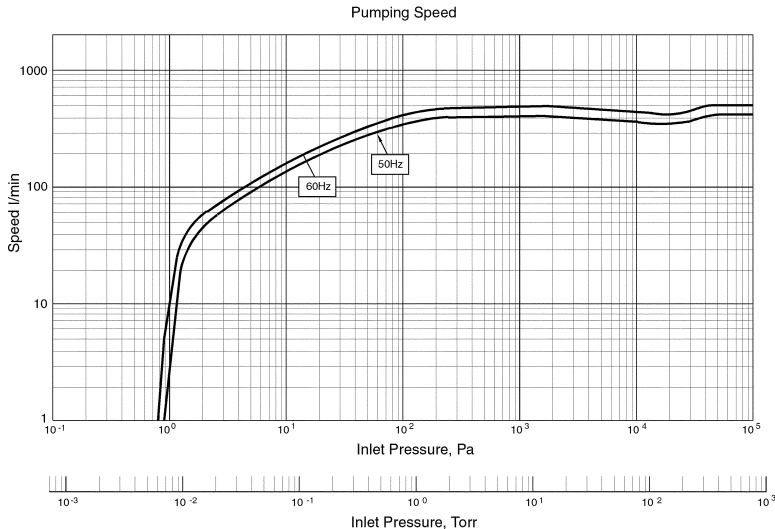

Figure 2 Pumping Speed Curves

TriScroll 620 Series Vacuum Pump

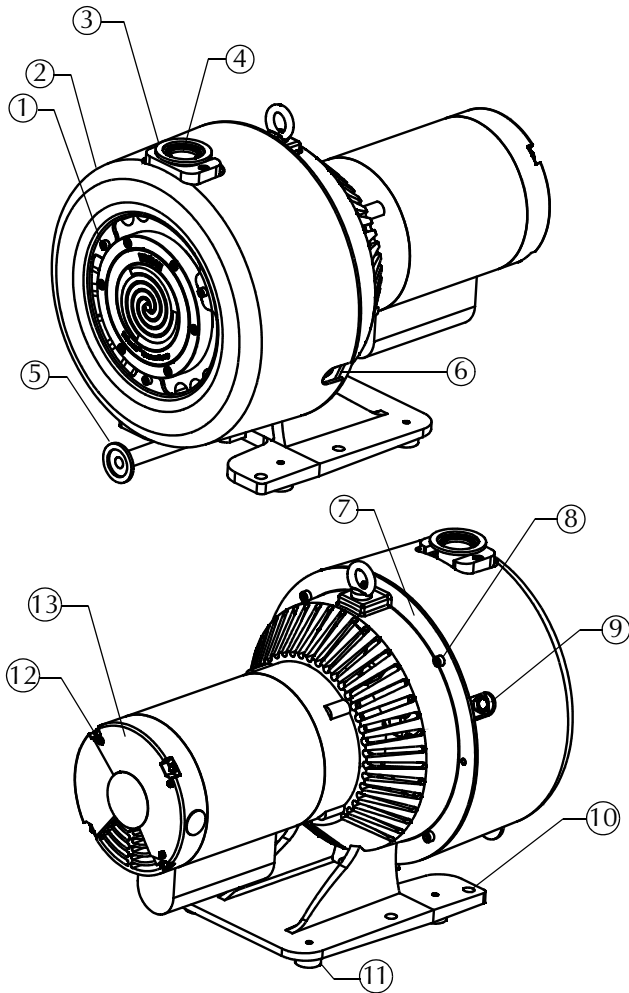

Figure 3 TriScroll 620 Vacuum Pump

1. Cowling Screws; M5 (3)
2. Cowling
3. Inlet (NW25)
4. Inlet Screen
5. NW25 Exhaust Adapter
6. Bearing Purge Port (1/4" National Pipe Thread)
7. Pump Frame
8. Frame Screws; M6 (4)
9. Gas Ballast Port (1/4" National Pipe Thread)
10. Mounting Holes; 11 mm diameter thru (8)
11. Rubber Feet (4)
12. Motor Cover Screws (3)
13. Motor Electrical Cover

Unpacking and Inspection

The shipping container is a double carton.

1. After opening the outer box, remove the foam packing.
2. Slit open the inner box.
3. Lift the pump with the plywood base out of the inner box.
4. Remove the four bolts securing the pump frame to the plywood base.
5. Locate the NW25 exhaust fitting and set it aside.
6. Inspect the pump for damage. If there is shipping damage, contact the freight carrier and your local Varian sales office immediately.
7. Save the carton and packing materials.

Installation

Safety

Do not remove or modify any safety or insulating equipment from the pump. To do so may create a serious safety hazard and may void the warranty.

WARNING



❑ *This pump is designed to pump air and inert gases only; it is not designed to pump explosive, flammable, toxic, or corrosive gases. They can cause bodily injury, explosion, or fire.*

❑ *Install in an area that is not exposed to rain, steam, or excessive humidity. They can cause electric shock, short circuits, and severe bodily injury.*

❑ *Before inspecting or servicing the pump, be sure the electrical supply is disconnected.*

❑ *Protect against short circuits by installing a circuit breaker of the proper capacity.*

CAUTION



Although the pump can pump trace particulates normally found in the atmosphere, it is not designed for process solids, chemicals, powders, solvents, condensates, or other particulates. They can damage the equipment, degrade its performance, or shorten its useful life.

Consult a qualified electrician whenever wiring the pump.

TriScroll Series pumps operate in a clockwise direction when viewed from the motor end. (Note the arrow on the pump frame.) Improper rotation can cause permanent damage to the pump.

Startup

1. Check that the inlet screen is installed before beginning operation.

WARNING



Do not insert a finger or any foreign object in the path of the fan; serious personal injury may result or the pump may be damaged.

2. Operate the pump at an ambient temperature of 5° C to 40° C (41° F to 104° F), otherwise damage to the pump or shortened operating life may result.

CAUTION



Do not block the fan ducts because the pump can become overheated. A pump surface temperature in excess of 55 °C (131 °F) is potentially damaging. If such conditions are observed, turn pump off and allow to cool. Disassemble, inspect for damage, and repair if necessary.

3. Close the isolation valve between the vacuum pump and the vacuum chamber before startup or shutdown; debris may be sucked back into the vacuum chamber.

An optional isolation valve can be installed for this purpose. See "Optional Isolation Valve" on page 8.

Electrical Connections

Wire the motor and electrical interlocks (if applicable) in accordance with local electrical codes and the relevant electrical component manufacturer's instructions. Table 2 lists the full load motor currents at various voltages.

Table 2 Full Load Motor Currents, Amps

1 phase motor	100 V	115 V	200 V	230 V
50 Hz	14	13.6	7.0	6.8
60 Hz	15.2	12.6	7.6	6.3

Single Phase Motor Connection

The pump can be configured for low voltage, 100 VAC to 115 VAC, or for high voltage, 200 VAC to 230 VAC. As supplied from the factory, the pump is configured for low voltage. Figure 4 shows the electrical connections for a single phase motor.

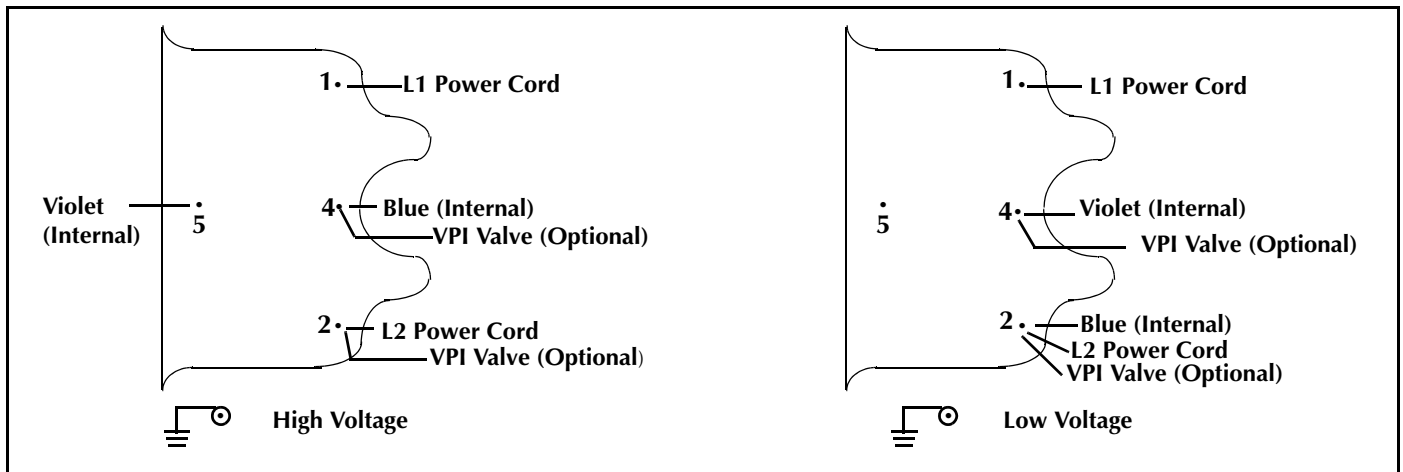

Figure 4 Single Phase Motor Electrical Connections

1. Verify the electrical supply voltage.
2. Remove the three screws (item 12 in Figure 3 on page 5) that are holding the motor electrical cover (item 13 in Figure 3).
3. Refer to Figure 4 to connect the motor to match your supply voltage.
4. Wire L1 and L2 per Figure 4 using right angle flag connectors or ring connectors.
5. Secure the ground wire under the ground screw using a ring connector.
6. Replace the motor electrical cover and secure it with the three (3) screws removed in step 2.

Two options are available to strain relieve the electrical supply cable.

- ❑ The cable can be mechanically held under the electrical cover in the groove provided. The groove is sized for 14 gage cable.
 - ❑ A 1/2–14 NPSM hole is also provided next to the motor cover.
4. Wire L1 and L2 per Figure 4 using right angle flag connectors or ring connectors.

Ensure that no exposed wiring is close to the electrical cover or to other terminals on the board.

Mechanical Connections

Pump Location

Locate the pump on a firm, level surface.

Mounting holes provided in the frame can be used to provide permanent attachment. The rubber mounts on the frame can be removed if desired.

Rotation of the Pump Inlet with Respect to the Motor Frame

The standard pump configuration is with the inlet fitting positioned at the top of the pump as shown in Figure 1 on page 4. The pump inlet has two alternate positions:

- ❑ 90 degrees clockwise
- ❑ 90 degrees counterclockwise

To rotate the inlet:

1. Remove three (3) M5 screws (item 1 on Figure 3 on page 5) that secure the cowling (item 2 on Figure 3) to the scroll module. Remove the cowling.
2. Tilt the pump back so that the rear end of the motor touches the floor.
3. Remove the four (4) M6 screws (item 8 on Figure 3) holding the frame (item 7 on Figure 3) and scroll module together.
4. Axially separate the frame and scroll module.
5. Rotate the module 90 degrees in either direction and realign the two (2) locating pins on the scroll module with the mating frame holes. Ensure that the rubber spider is still on the motor coupling and that the coupling teeth are properly aligned.
6. Rejoin the scroll module with the frame and install and tighten the four (4) M6 screws removed in step 3.
7. Reinstall the cowling using the three (3) M5 screws removed in step 1.

Pump Inlet

Use NW25, or larger, clean vacuum hardware with as short a length as practical between the pump and the vacuum chamber.

Use a bellows to provide both vibration isolation and strain relief between the pump and the vacuum chamber.

Pump Exhaust

A female 1/4" National Pipe Thread exhaust fitting is located underneath the scroll module. This fitting swivels 360 degrees. Additionally, an NW25 male adapter with 3/8" National Pipe Thread is provided.

To avoid overheating the pump, do not restrict the exhaust flow with long lengths of small diameter tubing. Use as short as practical lengths of NW25 diameter, or larger, hardware.

Optional Isolation Valve

Scroll pumps return to atmospheric pressure quickly when shut off, thus the installation of a fast acting, automatic, normally closed isolation valve is strongly recommended to prevent pump debris from being transported back into the vacuum chamber when the pump is turned off.

- ❑ The opening of this valve should occur simultaneously with or after pump startup.
- ❑ Valve closing should occur before, simultaneously with, but no later than 250 ms after pump shut off.

Use an NW25 valve or larger and mount it as close as possible to the pump inlet. Mounting to the pump inlet is ideal. (See Figure 5).

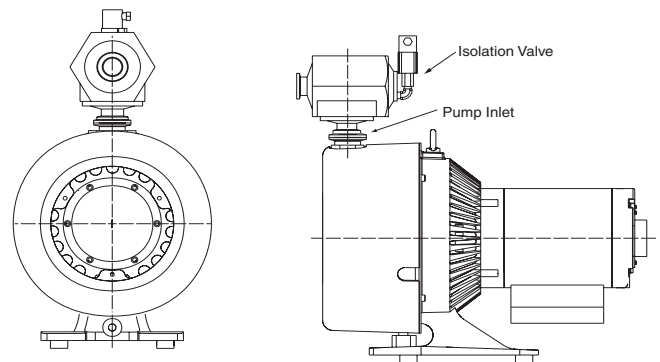

Figure 5 Isolation Valve Location

Varian offers a variety of manual, electromagnetic and electropneumatic controlled vacuum valves for vacuum applications. The Varian Vacuum Pump Isolation (VPI) Valve is highly recommended for vacuum pump isolation applications. The VPI valve application and installation information for use with TriScroll vacuum pumps has been included below.

Overview

The status of the VPI Valve is controlled by the TriScroll motor internal thermal switch and its electrical supply. The VPI Valve opens when the pump is running and closes when it is stopped. It will also close when the TriScroll motor thermal overload protection switch shuts down the pump.

CAUTION



To prevent damage to the VPI Valve, it must be installed by a qualified electrician and only as specified below.

TriScroll 620 Series Vacuum Pump

Wiring

Using the data in Table 3, verify that the VPI Valve chosen is compatible with the TriScroll supply voltage and frequency. Then, locate the proper wiring diagram to use (Figure 4 on page 7).

1. Remove the three screws (item 12 in Figure 3 on page 5) that are holding the motor electrical cover (item 13 in Figure 3).
2. Connect the VPI Valve solenoid wire leads to the pump motor as shown in Figure 4.
3. Replace the motor electrical cover and secure it using the three screws removed in step 1. Verify that the valve is properly grounded before applying electrical power.

Table 3 VPI Valve Installation Data

Motor	TriScroll Vacuum Pump Operating Voltage	VPI Valve Part # NW25	VPI Valve Part # NW40	Solenoid Operating Voltage Range	Use the following Wiring Diagram
1 Phase	100-120 V 50/60 Hz	VPI251205060	VPI401205060	90-132 V	Figure 4 low voltage
1 Phase	200-230 V 50/60 Hz	VPI251205060	VPI401205060	90-132 V*	Figure 4 high voltage

* Solenoid operating voltages are lower than the TriScroll vacuum pump operating voltages in order to utilize the TriScroll motor's internal thermal switch to actuate the VPI Valve.

Gas Ballast

The gas ballast port (item 9 on Figure 3 on page 5) is sealed on the TriScroll 620.

For applications where a lot of water is being pumped, dry nitrogen at a flow rate of ≈ 5 lpm can be bled into the gas ballast port. See "Purge Kit" below.

Bearing Purge

The bearing purge port (item 6 on Figure 3 on page 5) is sealed on the TriScroll 620 and must not be opened or used.

CAUTION



The bearing purge port has been disabled on the TriScroll 620 model. Use of this port could cause internal damage to the pump.

Purge Kit

A purge kit (Varian part number PTSPURGEKIT) to properly purge the gas ballast is available. This kit contains a flow meter and all necessary valving and tubing.

TriScroll 620 Series Vacuum Pump

Troubleshooting

Table 4 contains a list of possible problems, their probable causes, and corrective actions.

Table 4 Troubleshooting Chart

Problem	Probable Cause	Corrective Action
Pump won't start	Circuit breaker open	Close breaker. Identify cause of overload.
	Motor thermal protector open	Allow motor to cool. Identify cause of overload.
	Electrical short under the motor electrical cover	Inspect and repair.
	Wiring loose or cut	Repair or replace.
	Excessive voltage drop	Check size and length of power supply cable.
	Defective motor	Inspect. Contact Varian.
Poor ultimate pressure	System leak	Locate and repair leak.
	Water in pump	Flush pump with air or dry nitrogen.
	Gas ballast plugged	Replace breather vent. Contact Varian.
	Solvent in pump	Flush pump with air or dry nitrogen. Install trap or filter.
	Seals worn out	Replace tip seals. (Table 6 and Table 7 on page 11 list maintenance kits and service options.)
	Poor conductance to pump	Replumb with shorter and/or larger diameter tubing.
Pump makes hammering noise	Pump overheated	Check ambient temperature. Check ventilation to pump.
	Debris in pump	Check inlet screen. Flush pump. Disassemble pump and inspect. (Table 6 and Table 7 on page 11 list maintenance kits and service options.)

Maintenance

General Information

Varian TriScroll 600 series pumps are designed to provide years of trouble-free service if maintenance procedures and intervals are observed. Bearing grease replenishment and tip seal replacement is recommended when pump base pressure has risen to an unacceptably high level for your application. Bearings, rotary seals and o-rings should also be replaced if the pump exhibits humming or grinding noises from the bearings.

Maintenance should be performed in accordance with procedures, tooling and materials specified in the manuals listed below.

Related TriScroll Manuals

Other manuals related to tip seal replacement, pump module replacement, and major maintenance of the TriScroll 600 series pumps are listed in Table 5.

Table 5 Other Related Manuals

Title	Applicable TriScroll Model	Part Number
Tip Seal Replacement Manual	All TriScroll 600 Series models	699904310
Pump Module Replacement Manual	All TriScroll 600 Series models	699904305
Major Maintenance Manual	All TriScroll 600 Series models	699904300

Maintenance and Tooling Kits

Material and tooling required to perform maintenance on TriScroll pumps is provided in kit form. A description of each kit and ordering information is provided in Table 6.

Table 6 Maintenance and Tooling Kits

Description	Contents	Applicable TriScroll Model	Part Number
Major Maintenance Kit	All bearings, bearing seals, bearing lubricant, O-rings, and tip seals required to rebuild TriScroll 600 series pumps.	All TriScroll 600 Series models	PTSS0600MK
Maintenance Tool Kit	All fixtures and tools required to perform any maintenance on TriScroll 600 Series pumps.	All TriScroll 600 Series models	PTSS0600TK
Replacement Tip Seal Set	Replacement tip seals and static O-rings for TriScroll 600 Series pumps. <i>NOTE: The Maintenance Tool Kit is also required for tip seal replacement.</i>	All TriScroll 600 Series models	PTSS0600TS

TriScroll 620 Series Vacuum Pump

Factory Service Options

Table 7 lists the factory-rebuild service and advance exchange of complete TriScroll 600 series pumps, as well as factory service options that Varian offers.

Table 7 Factory Service Options

Factory Service Options	Part Number
Advance Exchange TriScroll 620 Single Phase	EXPTS06201ULD
Advance Exchange TriScroll 620 Pump Module Only	EXPTS0620SC
Service/Rebuild TriScroll 620 Pump	PTS0620KMA

Accessories

The accessories listed in Table 8 are available for use with the TriScroll 600 series pump. Contact your local Varian office to place an order. A list of offices is included on the rear cover of this manual.

Table 8 Accessories

Purge Kit	PTSPURGEKIT
Exhaust Extension	S4807001
Exhaust Filter Kit	PTS600EXFIL

Contacting Varian Varian

In the United States, you can contact Varian Customer Service at 1-800-8VARIAN. See the back cover of this manual for a listing of our sales and service offices.

Internet users:

- Send email to Customer Service & Technical Support at vpl.customer.support@varianinc.com
- Visit our web site at www.varianinc.com/vacuum
- Order on line at www.evarian.com