

TURBOVAC and MAG

Turbomolecular Pumps

35 - 3 200 l x s⁻¹

175.01.02

Excerpt from the Oerlikon Leybold Vacuum Full Line Catalog

Product Section C09

Edition March 2008

Contents

General

General	C09.03
Applications	C09.12
Accessories	C09.13

Products and Accessories

Turbomolecular Pumps with Mechanical Rotor Suspension	
without Compound Stage	C09.14
with Compound Stage	C09.40
Special Turbomolecular Pumps	C09.58
Electronic Frequency Converters	
for Turbomolecular Pumps with Mechanical Rotor Suspension	C09.60
Turbomolecular Pumps with Magnetic Rotor Suspension,	
with integrated Frequency Converter	
with Compound Stage	C09.68
with separate Frequency Converter	
without Compound Stage	C09.76
with Compound Stage	C09.78
Electronic Frequency Converters	
for Turbomolecular Pumps with Magnetic Rotor Suspension	C09.106

(Miscellaneous) Accessories

Vibration Absorber	C09.112
Air Cooling Unit	C09.112
Flange Heater for CF High Vacuum Flanges	C09.113
Fine Filter	C09.113
Solenoid Venting Valve	C09.114
Power Failure Venting Valve	C09.114
Purge Gas and Venting Valve	C09.114
Accessories for Serial Interfaces RS 232 C and RS 485 C	C09.115

Miscellaneous

Service	C09.118
---------------	---------

General

The turbomolecular pumps from Oerlikon Leybold Vacuum generate a clean high and ultra-high vacuum, are easy to operate and are exceptionally reliable. In connection with a well rated backing pump, pressures below 10^{-10} mbar (0.75×10^{-10} Torr) can be attained.

Oerlikon Leybold Vacuum offers two product lines:

1. TURBOVAC line

Turbomolecular pumps with mechanical rotor suspension

2. TURBOVAC MAG line

Turbomolecular pumps with magnetic rotor suspension

Each of the two product lines contains “classic” turbomolecular pumps as well as turbomolecular pumps with a compound stage.

Oerlikon Leybold Vacuum is one of the world’s leading manufacturer of turbomolecular pumps. Consequently, the TURBOVAC and the TURBOVAC MAG pumps are successfully used in many applications. A list of the most important ones is given in the table “Applications” in the section “General”.

Principle of Operation

The turbomolecular pump is a turbine with blades. By the momentum transfer from the rapidly rotating rotor blades to the gas molecules their initially non-directed thermal motion is changed to a directed motion.



TURBOVAC TW 70 H turbomolecular pump with mechanical rotor suspension and dual compound stage



TURBOVAC TW 361 turbomolecular pump with mechanical rotor suspension



MAG W 1500 CT turbomolecular pump with magnetic rotor suspension and compound stage

Hence, the pumping process in a turbomolecular pump results from the directed motion of the gas molecules from the inlet flange to the fore-vacuum port.

In the **molecular flow range** - i.e. at pressures below 10^{-3} mbar (0.75×10^{-3} Torr) - the mean free path of the gas molecules is larger than the spacing between rotor and stator blades (typically some tenths of a millimeter). Consequently, the molecules collide primarily with the rotor blades with the result that the pumping process is highly efficient.

In the **range of laminar flow**, i.e. at pressures over 10^{-1} mbar (0.75×10^{-1} Torr) the situation is completely different. The effect of the rotor is impaired by the frequent collisions between the molecules. Therefore, a turbomolecular pump is not capable of pumping gases at atmospheric pressure thus necessitating the use of a suitably rated forevacuum pump.

To create the directed motion of the gas molecules, the tips of the rotor blades have to move at high speeds. Hence, a high rotational speed of the rotor is required. In the case of Oerlikon Leybold Vacuum turbomolecular pumps the rotor speeds vary from about 36,000 rpm for the larger rotor diameters (e.g. TURBOVAC 1000 about 20 cm (7.87 in.)) to 72,000 rpm. for small rotor diameters (e.g. TURBOVAC 50 about 6 cm (2.36 in.))

Characteristic Quantities

Pumping speed (volume flow rate), S , [$\text{l} \times \text{s}^{-1}$]

The pumping speed for a given type of gas depends on the diameter of the rotor and the high vacuum flange, the rotor/stator design, the rotor speed and the molecular weight of the gas. The pumping speed S is a non-linear function of the inlet pressure p_1 :

$$S = S(p_1).$$

Gas throughput, Q , [$\text{mbar} \times \text{l} \times \text{s}^{-1}$]

Gas throughput Q is linked to the pumping speed S and the inlet pressure p_1 through the relationship

$$Q = Q(p_1) = p_1 \cdot S(p_1).$$

The maximum permissible gas throughput Q_{max} is attained at the maximum permissible inlet pressure $p_{1, \text{max}}$:

$$Q_{\text{max}} = Q(p_{1, \text{max}}).$$

Compression, K

For a given type of gas, compression K is defined as the ratio between forevacuum pressure p_{VV} (= pressure on the forevacuum side of the turbomolecular pump) and the highvacuum pressure p_{HV} (= pressure on the highvacuum side of the turbomolecular pump):

$$k = k(p_{\text{VV}}) = p_{\text{VV}} / p_{\text{HV}} \\ = p_{\text{VV}} / p_{\text{HV}}(p_{\text{VV}}).$$

Compression depends very much on the gas throughput: at a given forevacuum pressure, compression increases when the gas throughput is reduced.

Idle compression, K_0

Idle compression K_0 of a turbomolecular pump is defined as the amount of compression of this pump at "Zero" gas throughput. What is problematic about this definition is the fact that the demanded "Zero" throughput can never be implemented in practice (finite leak rate, degassing of sealing components, desorption from wall surfaces). Data on idle compression need therefore to be gained from measurements run at extremely low throughputs.

Idle compression of a pump equipped with metal seals is significantly higher compared to the same pump sealed with O-rings.

Ultimate pressure (base pressure), p_{ult} , [mbar]

The ultimate pressure of a turbomolecular pump is defined as that pressure which is attained in the test chamber 48 hours after a 24 hour degassing period of the measurement system.

The ultimate pressure will chiefly depend on the foreline pump used and the type of seal used at the highvacuum flange.

TURBOVAC Product Line

The TURBOVAC pumps are turbo-molecular pumps with mechanical rotor suspension which are used in the pressure range from 10^{-1} mbar (0.75×10^{-1} Torr) to 10^{-10} mbar (0.75×10^{-10} Torr). Pumping speeds for air vary from $35 \text{ l} \times \text{s}^{-1}$ (inlet flange diameter = 40 mm (1.57 in.)) to $1,600 \text{ l} \times \text{s}^{-1}$ (inlet flange diameter = 250 mm (9.84 in.)).

Through the compact design, the most reliable ceramics ball bearings and the simplicity of operation, this line of pumps is used in all high-vacuum and ultrahigh vacuum areas of application.

In particular the TURBOVAC pumps are very successfully operated in mass spectroscopy applications, gas and liquid chromatographic analysis, CD, DVD and hard disk production, manufacturing of large-surface optical layers, and non-corrosive semiconductor fabrication processes.

The most important advantages of the TURBOVAC product line are:

- Oil-free pumps for the generation of clean high and ultra-high vacuum conditions
- Highly performance in any orientation
- Highly degree of operating reliability
- Easy to operate
- Compact design

Ceramic Ball Bearings Technology

All TURBOVAC pumps are fitted with **ceramic ball bearings**, i.e. **ceramic balls** are running in steel races. The bearings are **lubricated for life by grease**.

Ceramic balls are lighter, harder and smoother than balls made of steel. Therefore, with ceramic balls the wear on the races is significantly reduced. Consequently, the lifetime of the bearings, and hence the lifetime of the pump, is increased.

The **TURBOVAC pumps** fitted with grease-lubricated ceramic ball bearings **can be mounted in any orientation**.

As the ball bearing is encapsulated, the grease can not enter the highvacuum space, even if the pump is mounted up-side-down.

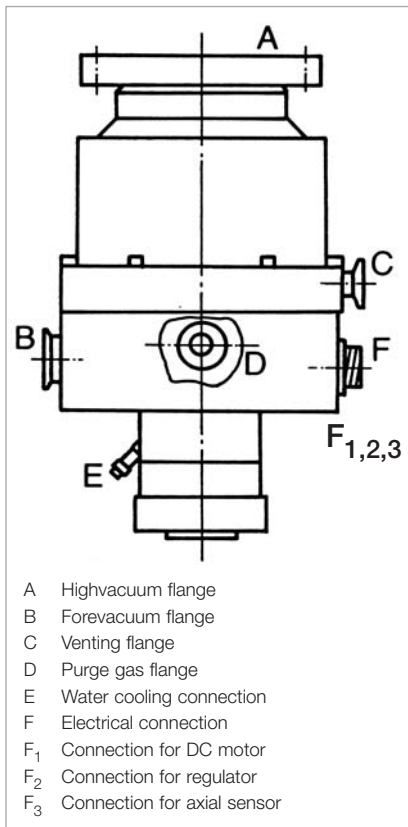

Flange designations used in this product section

Components supplied with the Turbomolecular Pumps

Highvacuum Flange

KF, ISO-K and ISO-F models

- Accessories need to be ordered separately

ANSI Models

- O-ring included in the delivery

CF Models

- Without gaskets ¹⁾, but with screws ²⁾

Forevacuum Port

- Centering rings, O-rings and clamps for all KF type forevacuum flanges are included.

Purge / vent ports are blanked-off

¹⁾ For CF gaskets, see Product Section C13

²⁾ Only for MAG pumps

TURBOVAC MAG Product Line

The **TURBOVAC MAG pumps** are **turbomolecular pumps with magnetic rotor suspension** which are used in the **pressure range from 10⁻¹ mbar (0.75 x 10⁻¹ Torr) to 10⁻¹⁰ mbar (0.75 x 10⁻¹⁰ Torr)**.

Pumping speeds for air vary from 300 l x s⁻¹ (inlet flange diameter = 100 mm (3.94 in.)) **to 3,200 l x s⁻¹** (inlet flange diameter = 320 mm (12.6 in.)).

The TURBOVAC MAG pumps are mostly installed on semiconductor processing lines like etching, CVD, PVD and ion implantation, i.e. in applications where corrosive gases need to be pumped. Also electron beam microscopy is an important area of application for these pumps.

The **most important advantages of the TURBOVAC MAG product line** are:

- Hydrocarbon-free pumps for the generation of clean high and ultra-high vacuum conditions
- High performance in any orientation
- High degree of operating reliability
- Extremely low vibration
- Designed for pumping of corrosive gases

Use of Turbomolecular Pumps in Analytical Instruments

All modern analytical methods for gas, liquid and plasma analysis – like for example GC-MS, LC-MS and ICP-MS – rely on mass spectrometers and for this reason require adequate highvacuum conditions. Also in electron microscopes and many surface analysis instruments the production of a highvacuum is essential.

In over 90 % of all highvacuum applications, the turbomolecular pump has been found to be ideal. Thanks to the hydrocarbon-free vacuum, most simple operation, compact design and almost maintenance-free operation it has in most cases displaced above all the diffusion pump.

On the basis of decades of experience and in cooperation with research facilities and the manufacturers of analytical instruments,

Oerlikon Leybold Vacuum has continually optimized its products.

Through the TURBOVAC wide range series, a further improvement has been attained, making available to users in the area of analytical engineering highly flexible and reliable products.

Owing to the modular concept the user may

- adapt his vacuum system precisely to his requirements
- perfectly integrate the components within his system and
- find the most cost-effective system configuration for his needs.

Moreover, in response to special customer requirements, though Oerlikon Leybold Vacuum has, through the introduction of the TURBOVAC multi inlet series, achieved a major step ahead for analytical instruments.

Up to three analysis chambers can be pumped down simultaneously by a single multi inlet pump. These pumps are fine tuned with regard to pumping speed and gas throughput so as to attain higher detection sensitivities for analytical systems, a smaller footprint and an increased sample throughput.

The benefits for the customers are the extreme compactness of the vacuum systems without sacrificing performance density, simple installation, stable vacuum connections and, compared to the use of discrete individual pumps, significantly lower investment costs for the entire system. The cartridge solution, moreover, allows for an innovative and cost-effective design of the customer's system and during servicing a simple replacement of the active unit without involved assembly work and leak searching.

Cartridge benefits, which convince

- Higher effective pumping speed
- No losses in conductance
- Compact vacuum system
- Easy pump replacement without having to disassemble the highly sensitive mass spectrometer chambers

The benefits for the customers using Oerlikon Leybold Vacuum products are reflected by the efficiency of the analytical instruments:

- Increase in detection sensitivity
- Smaller analytical systems
- Increase in sample throughput
- Reduction of system costs
- Lower maintenance costs

In combination with backing pumps like the TRIVAC or Scroll pump, Oerlikon Leybold Vacuum is able to offer the best vacuum system optimized for all major applications in the area of analytical instrumentation.

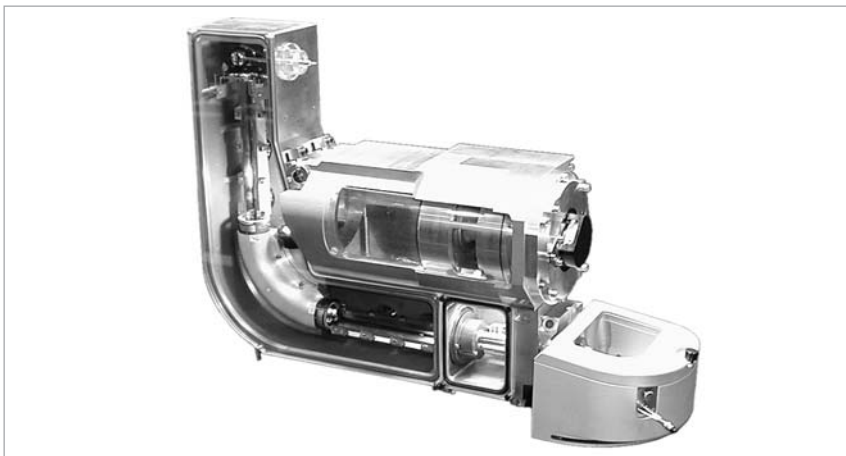

TURBOVAC multi Inlet TW 220/150/15 fitted in an analytical instrument
(by courtesy of Thermo Fisher Scientific)

Use of Turbomolecular Pumps in the Area of Semiconductor Processes

In the semiconductor industry turbomolecular pumps are used on the following processes, among others:

- Etching
- Sputtering
- Ion implantation
- CVD
- Lithography.

In these applications pumping of aggressive gases is often required.

This may necessitate the use of pumps equipped with a purge gas facility or a magnetic suspension in order to avoid damaged bearings. Especially during metal etching, deposits may occur in the fore-vacuum space of the turbomolecular pump. In order to prevent this the pumps must be heated to a certain temperature. Such temperature controlled variants are optionally available for the MAG 1500 C, MAG 2000 C, MAG 2800 and MAG 3200. In contrast to turbomolecular pumps with mechanical bearings, magnetically levitated pumps provide the advantage that they prevent overheating of the bearings at high gas flows and effectively exclude any damage to the magnetic bearings by aggressive media.

In electron microscopes and in lithographic equipment, low vibration levels are exceptionally important. For this reason magnetically levitated turbomolecular pumps should be used here.

The recommended backing pumps are either dry compressing ECODRY pumps or rotary vane pumps from the TRIVAC range, possibly fitted with the BCS system.

Use of Turbomolecular Pumps in the Area of Coating Systems

Coating of optical and magnetic storage media, optical components as well as architectural glass requires highvacuum conditions. This is the only way to ensure that the formed layers will be uniform and adhere to the substrate.

The way in which the vacuum is generated has a significant impact on the quality of the coating. By pumping the vacuum chamber down to pressures in the range of 10^{-6} mbar (0.75×10^{-6} Torr), interfering gas and water molecules are removed from the processing chamber. In the case of sputtering the coating process is run in the pressure range between 10^{-3} and 10^{-2} mbar (0.75×10^{-3} and 0.75×10^{-2} Torr), and in the case of evaporation coating, pressures below 10^{-4} mbar (0.75×10^{-4} Torr) are utilized.

The turbomolecular pump meets all requirements of the customers as to a hydrocarbon-free vacuum, very simple operation, compact design and almost maintenance-free operation in an almost ideal manner. The range of pumps from Oerlikon Leybold Vacuum includes pumps with flange diameters ranging from 40 mm to 250 mm (1.57 in. to 9.84 in.) nominal width. Thus the right pump is available for each application, be it coating of data memories (CD, DVD, hard discs), coating of tools and coating of precision lenses in the area of optical components, displays or architectural glass.



Entire high vacuum equipment of a CD/DVD coating system with TURBOVAC TW 250 S pumps

Research and Development

In the area of research, all types of turbomolecular pumps from Oerlikon Leybold Vacuum are being used.

In the case of particularly stringent requirements such as low vibration levels, a TURBOVAC with magnetic bearings should be selected; the same applies to those applications in which entirely hydrocarbon-free pump systems are required.

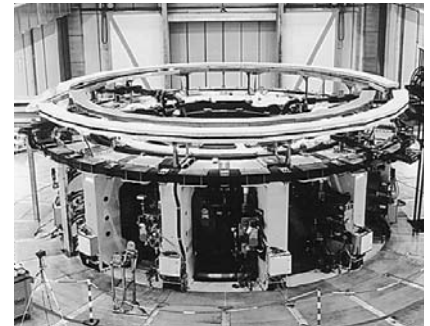

Nuclear fusion technology



High performance glass coating plant

Pump / Converter Configurations for TURBOVAC Product Line

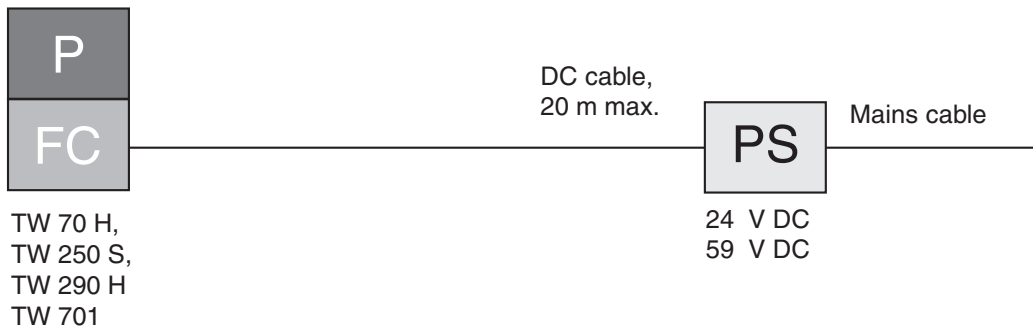
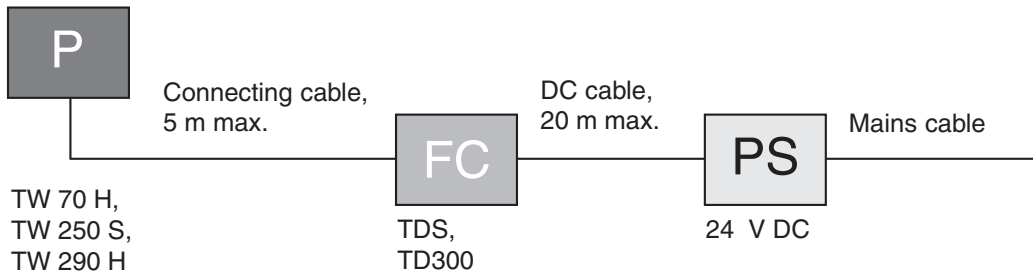
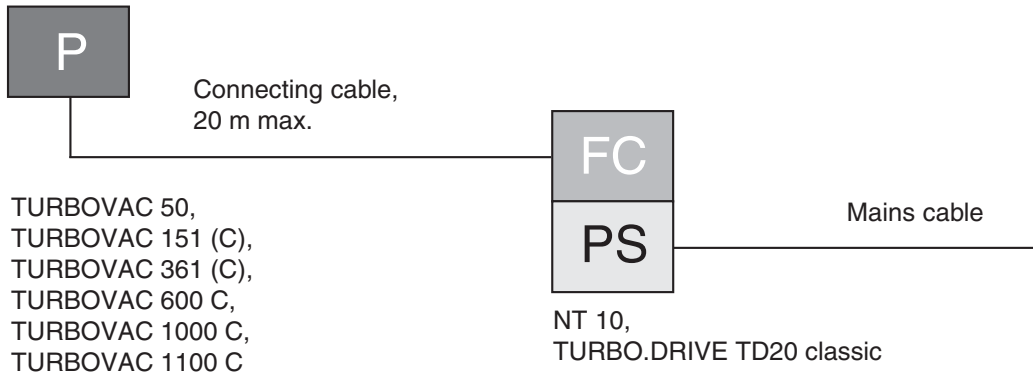

P= Pump

FC = Frequency Converter

PS = Power Supply



MAG W 1300 C turbomolecular pump with magnetic rotor suspension and compound stage

Magnetic Bearings Technology

The world-wide success of the TURBOVAC MAG product line results from more than **30 years of experience** of Oerlikon Leybold Vacuum in the development and manufacturing of turbomolecular pumps with magnetically levitated rotors.

In 1976 Oerlikon Leybold Vacuum started the market introduction of the famous TURBOVAC 560 M. This was the first magnetically levitated turbomolecular pump which became commercially available. Today, Oerlikon Leybold Vacuum is employing the well-proven and reliable 5 axes active suspension design principle.

Five axes with active bearings

The rotor position is actively controlled by electromagnets in all 5 degrees of freedom. The TURBOVAC MAG 300/400, MAG 600/700, MAG 830/1300, MAG 1500, MAG 2000, MAG 2200 and MAG 2800/3200 are equipped with such a bearing system.

Pump / Converter Configurations for TURBOVAC MAG Product Line

With integrated Frequency Converter

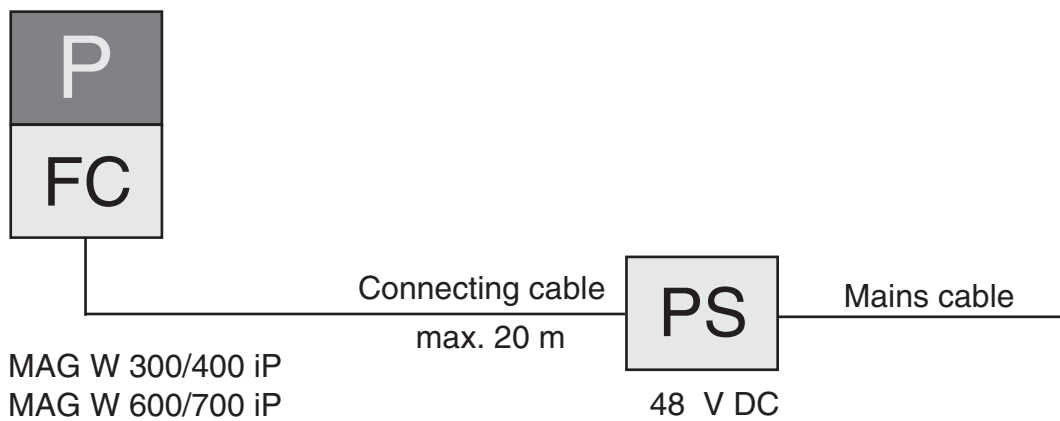

With separate Frequency Converter

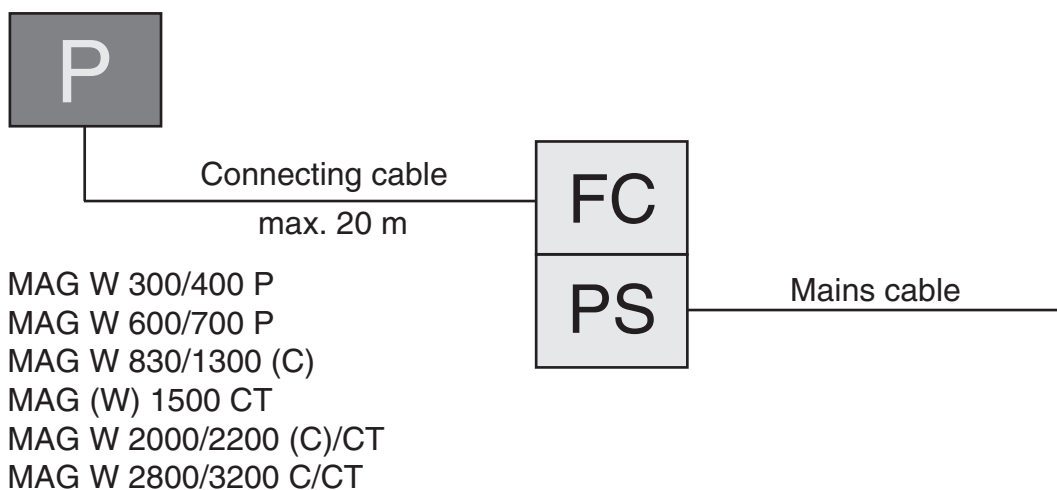

Application

Pumps	50	151, 361	600 C	1000 C	1100 C	T 1600	TW 70 H	TW 230 S	TW 290 H	TW 701	TW 1600	MAG W 300/400/600/700 IP	MAG 1500 CT	MAG W 300/400/600/700 P	MAG W 830/1300 C	MAG W 1500 CT	MAG W 2200 C	MAG W 2000 C/CT	MAG W 2800/3200 C/CT
Applications																			
Analytical Instruments																			
Leak detectors	■	■				■	■			■		■	■						
Mass spectrometers	■	■				■	■	■		■		■	■						
Gas chromatography (GC-MS)	■	■					■			■		■	■						
Liquid chromatography (LC-MS)	■	■					■	■		■		■	■						
Quadrupol time of flight (Q-TOF)								■	■		■	■	■						
Matrix assisted laser desorption time of flight (MALDI-TOF)	■							■	■		■	■	■						
Inductively coupled plasma mass spectrometry (ICP-MS)	■						■	■	■		■	■	■						
Electron beam microscopy	■					■				■	■	■	■						
Coating																			
Data storage / optical		■					■	■		■		■	■		■	■	■	■	■
Data storage / magnetic			■	■	■	■	■		■	■	■	■	■		■	■	■	■	■
Flat panel displays			■	■	■	■			■	■	■	■	■		■	■	■	■	■
Optical coating		■	■	■	■	■	■	■		■	■	■	■		■	■	■	■	■
Large area coating				■	■	■								■	■	■	■	■	■
Decorative coating				■	■	■								■	■	■	■	■	■
Metallization				■	■	■								■	■	■	■	■	■
Wear protection			■	■	■	■								■	■	■	■	■	■
Metallurgy				■	■	■								■	■	■	■	■	■
TV tube manufacturing	■					■	■												
R & D (Research and Development)																			
Surface analysis				■		■				■	■	■	■	■	■	■	■	■	■
UHV / XHV systems		■	■	■	■			■	■	■	■	■	■	■	■	■	■	■	■
Particle accelerators		■		■	■	■		■	■	■	■	■	■	■	■	■	■	■	■
Fusion experiments			■	■	■	■				■	■	■	■	■	■	■	■	■	■
Space simulation			■	■	■					■	■	■	■	■	■	■	■	■	■
Semiconductor Processes																			
Load locks and transfer chambers	■	■	■	■	■		■	■	■	■	■	■	■						
Etch												■		■		■	■		
PECVD												■	■	■	■	■	■	■	■
PVD												■	■	■	■	■	■	■	■
Ion implantation												■	■	■	■	■	■	■	■

Accessories

Pumps																				
	50	151, 361	600 C	1000 C	1100 C	T 1600	TW 70 H	TW 250 S	TW 290 H	TW 701	TW 1600	MAG W 300/400/600/700 IP	MAG 1500 CT	MAG W 300/400/600/700 P	MAG W 830/1300 C	MAG W 1500 CT	MAG W 2200 C	MAG W 2000 C/CT	MAG W 2800/3200 C/CT	
Accessories	Page																			
Frequency converters																				
TURBO.DRIVE TD20 <i>classic</i>	C09.60	■	■	■	■															
NT 10	C09.62	■																		
TURBO.DRIVE S	C09.63	■				■	■	■												
TURBO.DRIVE 300	C09.64					■	■	■												
Power supply PS 700	C09.65								■											
Power supplies for TD S/TD 300, TW 700/701	C09.66					■	■	■	■											
MAG.DRIVE S	C09.106												■							
MAG.DRIVE digital	C09.108											■	■	■	■	■	■	■		
Power supply TURBO.POWER 500	C09.110									■										
Vibration absorber	C09.112	■	■	■	■	■	■	■	■	■	■	■	■							
Air cooling unit	C09.112	■	■	■	■						■	■								
Flange heaters für CF flanges	C09.113	■	■	■	■		■	■	■	■	■	■								
Fine filter	C09.113	■																		
Venting valves	C09.114	■	■	■	■	■		■	■	■	■	■	■	■	■					
Power failure venting valve	C09.114		■	■	■	■	■	■	■	■	■	■	■	■	■	■	■	■	■	■
Purge gas and venting valve	C09.114	■	■	■	■	■	■	■	■	■			■		■					
Water cooling	-	■									■	■								
Accessories for RS 232 C / RS 485 C-serial interfaces	C09.115	■	■	■	■	■	■	■	■	■	■	■	■	■	■	■	■	■	■	■

Products and Accessories

Turbomolecular Pumps with Mechanical Rotor Suspension without Compound Stage TURBOVAC 50



Typical Applications

- Leak detectors
- Mass spectrometers
- Electron beam microscopy
- TV tube manufacturing
- Load locks and transfer chambers

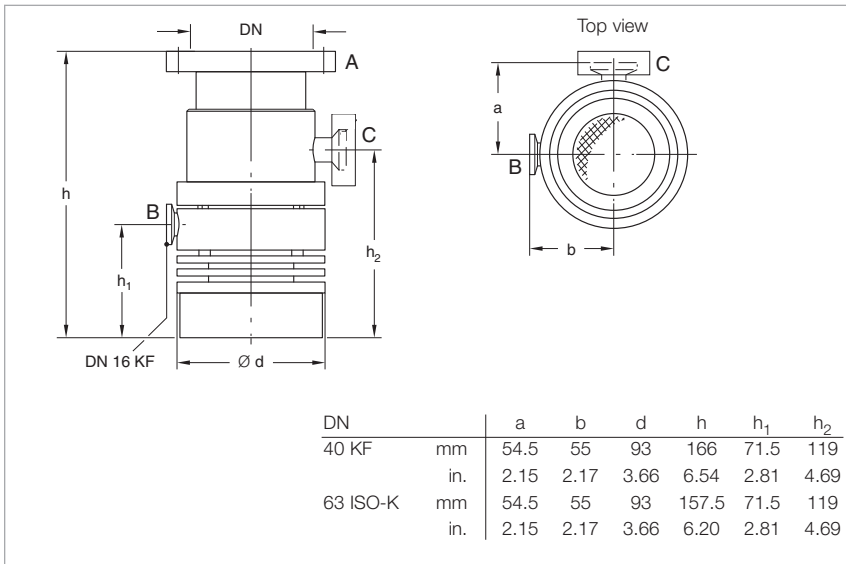

Dimensional drawing for the TURBOVAC 50

Technical Features

- Compact design
- Operation in any orientation
- Cooling by convection is sufficient for most applications
- Air and water cooling can be added easily
- Oil-free pump for generating clean high and ultrahigh vacuum conditions

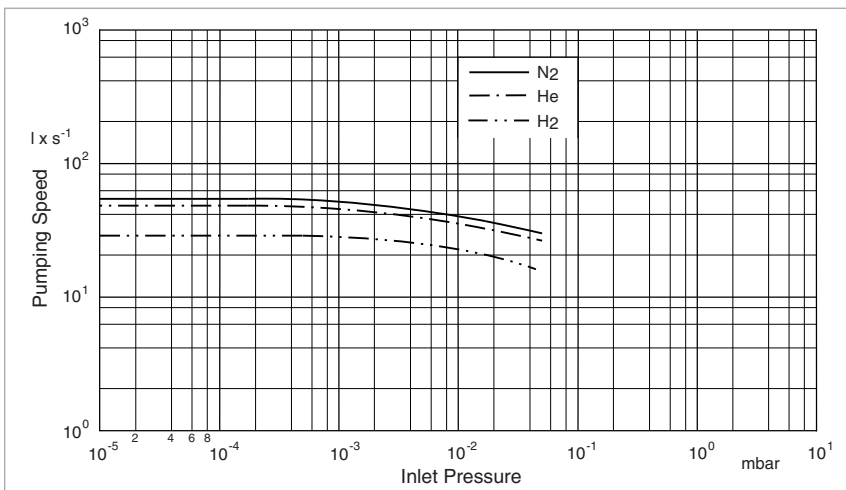

Pumping speed as a function of the inlet pressure (TURBOVAC 50 with flange DN 63 ISO-K)

Advantages to the User

- Space-saving
- Easy to integrate into complex vacuum systems
- Low operating costs
- Highly reliable operation also in processes loaded with particles

Technical Data

TURBOVAC 50

Inlet flange	DN	O-ring sealed 40 KF	O-ring sealed 63 ISO-K
Pump housing		Aluminum	Aluminum
Pumping speed at 10^{-3} mbar			
N ₂	l x s ⁻¹	33	55
He	l x s ⁻¹	36	48
H ₂	l x s ⁻¹	28	30
Max. gas throughput ¹⁾ at 10^{-2} mbar			
N ₂	mbar x l x s ⁻¹	0.30	0.40
He	mbar x l x s ⁻¹	0.25	0.35
H ₂	mbar x l x s ⁻¹	0.20	0.25
Max. compression when idle			
N ₂		$2 \cdot 10^6$	$2 \cdot 10^6$
Ultimate pressure with TRIVAC D 2,5 E	mbar (Torr)	$< 5 \times 10^{-8}$ ($< 3.75 \times 10^{-8}$)	$< 5 \times 10^{-8}$ ($< 3.75 \times 10^{-8}$)
Max. foreline pressure for N ₂	mbar (Torr)	1×10^{-1} ($< 0.75 \times 10^{-1}$)	1×10^{-1} ($< 0.75 \times 10^{-1}$)
Recommended forevacuum pump		TRIVAC D 2,5 E	TRIVAC D 2,5 E
Run-up time to 95% of nominal speed	min	2	2
Cooling water connection (hose nozzles) (for Part No. 854 08)	mm (in.)	10	10
Weight, approx.	kg	2	2
Max. power consumption	VA	45	45

¹⁾ for continuous operation when water-cooled

Ordering Information

TURBOVAC 50

Inlet flange	Foreline flange	Cooling method	Interface	
DN 40 KF	DN 16 KF	Convection	-	Part No. 854 00
DN 63 ISO-K	DN 16 KF	Convection	-	Part No. 854 01
Accessories, necessary for all pumps				
Electronic frequency converter NT 10				
90 - 140 V				Part No. 859 01
180 - 260 V				Part No. 859 00
Connecting cable NT 10 - pump				
3 m (10.5 ft)				Part No. 121 08
5 m (17.5 ft)				Part No. 121 09
Accessories, optional				
Air cooling unit				
230 V AC				Part No. 854 05
110 V AC				Part No. 854 06
100 V AC				Part No. 800152V0015
Water cooling kit				Part No. 854 08
Flange heater				
63 CF, 230 V, 50 Hz				Part No. 854 04
63 CF, 110 V, 60 Hz				Part No. 854 07
Vibration absorber				
DN 63 ISO-K				Part No. 800131V0063
DN 63 CF				Part No. 500 070

TURBOVAC 151, 151 C

ClassicLine



Turbomolecular pumps without a purge gas facility are only suited for pumping of air or inert gases.

They are not suited for pumping of aggressive or reactive gases.

TURBOVAC pumps with a "C" in the type designation are equipped with a purge gas facility.

The purge gas protects only the bearing area and the motor of the TURBOVAC.

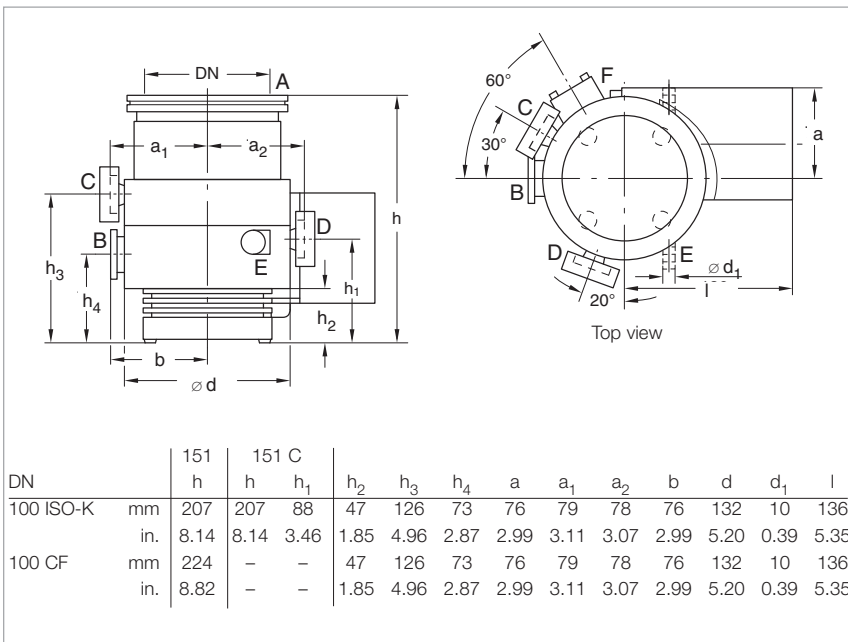

Dimensional drawing for the TURBOVAC 151 and 151 C

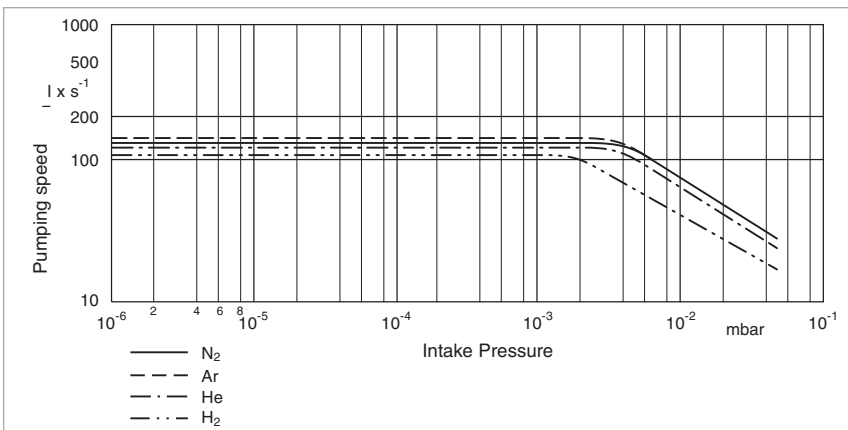

Pumping speed as a function of the inlet pressure (TURBOVAC 151 with flange DN 100)

Typical Applications

- Leak detectors
- Mass spectrometers
- Data storage
- Optical coating
- R & D, e.g.
 - UHV systems
 - Particle accelerators
- Load locks and transfer chambers

Technical Features

- Compact design
- Operation in any orientation
- Oil-free pump for generating clean high and ultrahigh vacuum-conditions

Advantages to the User

- Space-saving
- Easy to integrate into complex vacuum systems
- Low operating costs
- Highly reliable operation also in processes loaded with particles

Technical Data

TURBOVAC 151

Inlet flange	DN	100 ISO-K	100 CF
Pumping speed			
N ₂	l x s ⁻¹	145	145
Ar	l x s ⁻¹	150	150
He	l x s ⁻¹	135	135
H ₂	l x s ⁻¹	115	115
Max. gas throughput			
N ₂	mbar x l x s ⁻¹	1.5	1.5
Ar	mbar x l x s ⁻¹	1.3	1.3
H ₂	mbar x l x s ⁻¹	1.0	1.0
Compression ratio			
N ₂		1 x 10 ⁹	1 x 10 ⁹
He		2 x 10 ⁴	2 x 10 ⁴
H ₂		8 x 10 ²	8 x 10 ²
Ultimate pressure	mbar (Torr)	< 1 x 10 ⁻¹⁰ (< 0.75 x 10 ⁻¹⁰)	< 1 x 10 ⁻¹⁰ (< 0.75 x 10 ⁻¹⁰)
Max. continuous inlet pressure ¹⁾	mbar (Torr)	5 x 10 ⁻² (4 x 10 ⁻²)	5 x 10 ⁻² (4 x 10 ⁻²)
Max. foreline pressure for N₂	mbar (Torr)	5 x 10 ⁻¹ (4 x 10 ⁻¹)	5 x 10 ⁻¹ (4 x 10 ⁻¹)
Recommended forevacuum pump		from TRIVAC D 4 B to D 16 B	from TRIVAC D 4 B to D 16 B
Run-up time to 95% speed	min	≈ 2	≈ 2
Purge / vent port	DN	10 KF	10 KF
Cooling water connection (hose nozzles)	mm (in.)	10 (0.39)	10 (0.39)
Weight, approx.	kg (lbs)	8 (17)	88 (17)
Max. power consumption at ultimate pressure	VA	680	680
	VA	480	480

¹⁾ Water-cooled

Ordering Information

TURBOVAC 151

Inlet flange	Foreline flange	Cooling method	Item	
DN 100 ISO-K	DN 25 KF	Water-cooled	TURBOVAC 151	Part No. 856 31
DN 100 ISO-K	DN 25 KF	Water-cooled	TURBOVAC 151 C	Part No. 856 35
DN 100 CF	DN 25 KF	Water-cooled	TURBOVAC 151	Part No. 856 32
DN 100 CF	DN 25 KF	Water-cooled	TURBOVAC 151 C	Part No. 103 41
Accessories, necessary for all pumps				
Electronic frequency converter TURBO.DRIVE TD20 <i>classic</i> 100 - 240 V AC (-15%/+10%) without interface with RS 232 C interface with RS 485 C interface with Profibus with 25 pol I/O with DeviceNet with Ethernet/IP				Part No. 800075V0001 Part No. 800075V0002 Part No. 800075V0004 Part No. 800075V0003 Part No. 800075V0005 Part No. 800075V0006 Part No. 800075V0007
Connecting cable TURBO.DRIVE TD20 <i>classic</i> - pump 3 m (10.5 ft) 5 m (17.5 ft) 10 m (35.0 ft) 20 m (70.0 ft) 50 m (175.0 ft) 60 m (210.0 ft)				Part No. 857 65 Part No. 857 66 Part No. 857 67 Part No. 857 68 Part No. 800152V0008 Part No. 800152V0007
Accessories, optional				
Air cooling unit 230 V AC 110 V AC 100 V AC				Part No. 855 31 Part No. 894 08 Part No. 800152V0016
Flange heater 100 CF 230 V AC 110 V AC				Part No. 854 27 Part No. 854 28
Mains cable 3 m (10.5 ft) Euro plug UK plug US plug 6-15 P				Part No. 800102V0002 Part No. 800102V0003 Part No. 800102V1002

TURBOVAC 361, 361 C

ClassicLine



Turbomolecular pumps without a purge gas facility are only suited for pumping of air or inert gases.

They are not suited for pumping of aggressive or reactive gases.

TURBOVAC pumps with a "C" in the type designation are equipped with a purge gas facility.

The purge gas protects only the bearing area and the motor of the TURBOVAC.

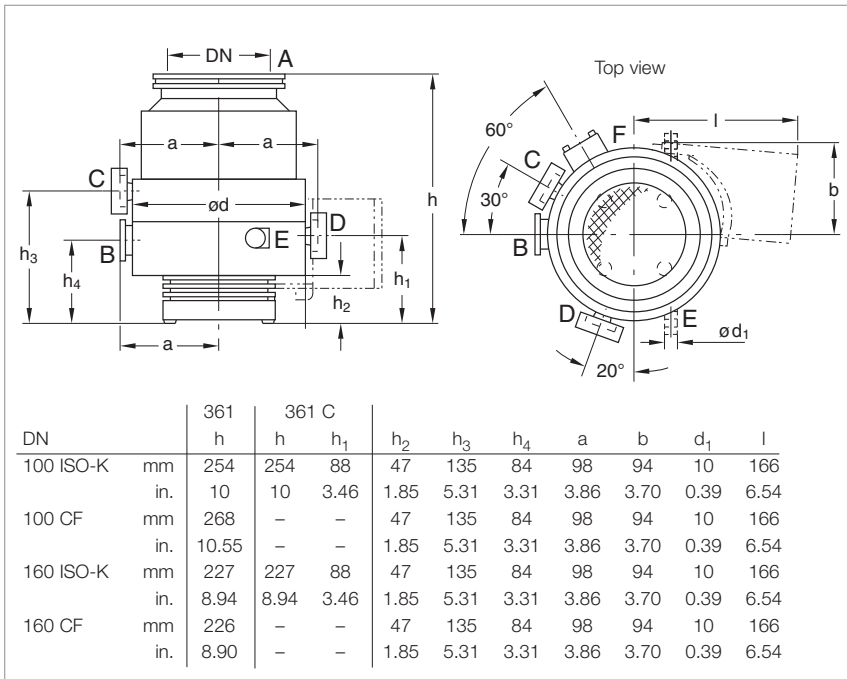

Dimensional drawing for the TURBOVAC 361 and 361 C

Typical Applications

- Leak detectors
- Mass spectrometers
- Data storage
- Optical coating
- R & D, e.g.
 - UHV systems
 - Particle accelerators
- Load locks and transfer chambers

Technical Features

- Compact design
- Operation in any orientation
- Oil-free pump for generating clean high and ultrahigh vacuum conditions

Advantages to the User

- Space-saving
- Easy to integrate into complex vacuum systems
- Low operating costs
- Highly reliable operation also in processes loaded with particles

Technical Data

TURBOVAC 361

Inlet flange	DN	100 ISO-K • 100 CF	160 ISO-K • 160 CF
Pumping speed			
N ₂	l x s ⁻¹	345	400
Ar	l x s ⁻¹	350	–
He	l x s ⁻¹	340	380
H ₂	l x s ⁻¹	340	370
Max. gas throughput			
N ₂	mbar x l x s ⁻¹	3.0	3.0
Ar	mbar x l x s ⁻¹	2.5	2.5
Compression ratio			
N ₂		1 x 10 ⁹	1 x 10 ⁹
He		6 x 10 ⁴	6 x 10 ⁴
H ₂		3 x 10 ³	3 x 10 ³
Ultimate pressure			
	mbar (Torr)	< 1 x 10 ⁻¹⁰ (< 0.75 x 10 ⁻¹⁰)	< 1 x 10 ⁻¹⁰ (< 0.75 x 10 ⁻¹⁰)
Max. continuous inlet pressure ¹⁾			
	mbar (Torr)	5 x 10 ⁻² (3.75 x 10 ⁻²)	5 x 10 ⁻² (3.75 x 10 ⁻²)
Max. foreline pressure for N₂			
	mbar (Torr)	5 x 10 ⁻¹ (3.75 x 10 ⁻¹)	5 x 10 ⁻¹ (3.75 x 10 ⁻¹)
Recommended forevacuum pump		from TRIVAC D 16 B to D 25 B	from TRIVAC D 16 B to D 25 B
Run-up time to 95% speed		min	min
		≈ 2	≈ 2
Purge / vent port		DN	DN
		10 KF	10 KF
Cooling water connection (hose nozzle)			
	mm (in.)	10 (0.39)	10 (0.39)
Weight, approx.		kg (lbs)	kg (lbs)
		12 (26)	12 (26)
Max. power consumption		VA	VA
		680	680
at ultimate pressure		VA	VA
		480	480

¹⁾ Water-cooled

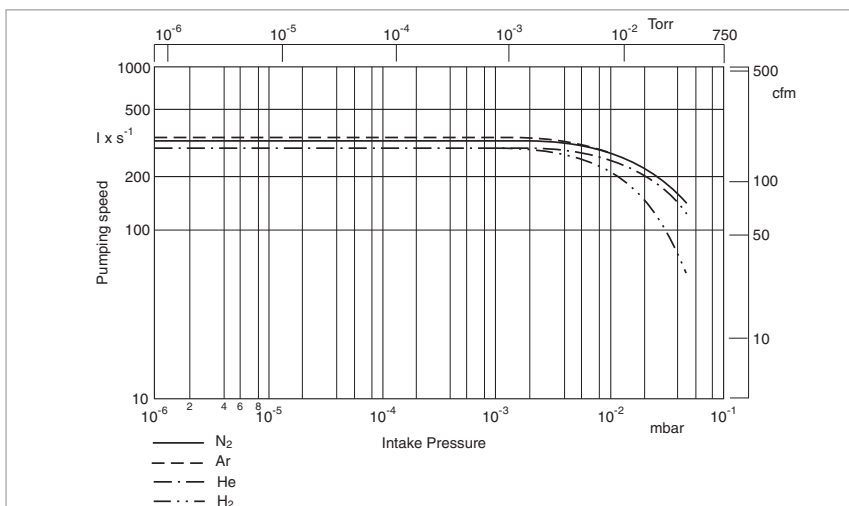

Pumping speed as a function of the inlet pressure (TURBOVAC 361 with flange DN 100)

Ordering Information

TURBOVAC 361

Inlet flange	Foreline flange	Cooling method	Item	
DN 100 ISO-K	DN 25 KF	Water-cooled	TURBOVAC 361	Part No. 856 70
DN 100 ISO-K	DN 25 KF	Water-cooled	TURBOVAC 361 C	Part No. 856 75
DN 100 CF	DN 25 KF	Water-cooled	TURBOVAC 361	Part No. 856 71
DN 160 ISO-K	DN 25 KF	Water-cooled	TURBOVAC 361	Part No. 856 72
DN 160 ISO-K	DN 25 KF	Water-cooled	TURBOVAC 361 C	Part No. 856 77
DN 160 CF	DN 25 KF	Water-cooled	TURBOVAC 361	Part No. 856 73
Accessories, necessary for all pumps				
Electronic frequency converter TURBO.DRIVE TD20 <i>classic</i> 100 - 240 V AC (-15%/+10%) without interface with RS 232 C interface with RS 485 C interface with Profibus with 25 pol I/O with DeviceNet with Ethernet/IP				Part No. 800075V0001 Part No. 800075V0002 Part No. 800075V0004 Part No. 800075V0003 Part No. 800075V0005 Part No. 800075V0006 Part No. 800075V0007
Connecting cable TURBO.DRIVE TD20 <i>classic</i> - pump 3 m (10.5 ft) 5 m (17.5 ft) 10 m (35.0 ft) 20 m (70.0 ft) 50 m (175.0 ft) 60 m (210.0 ft)				Part No. 857 65 Part No. 857 66 Part No. 857 67 Part No. 857 68 Part No. 800152V0008 Part No. 800152V0007
Accessories, optional				
Air cooling unit 230 V AC 110 V AC 100 V AC				Part No. 855 31 Part No. 894 08 Part No. 800152V0016
Flange heater 100 CF 230 V AC 110 V AC				Part No. 854 27 Part No. 854 28
Flange heater 160 CF 230 V AC 110 V AC				Part No. 854 37 Part No. 854 38
Mains cable 3 m (10.5 ft) Euro plug UK plug US plug 6-15 P				Part No. 800102V0002 Part No. 800102V0003 Part No. 800102V1002

TURBOVAC 600 C

ClassicLine



Typical Applications

- Load locks and transfer chambers
- Optical coating
- Flat panel displays
- R & D

Technical Features

- Compact design
- Operation in any orientation
- Oil-free pump for generating clean high and ultrahigh vacuum conditions

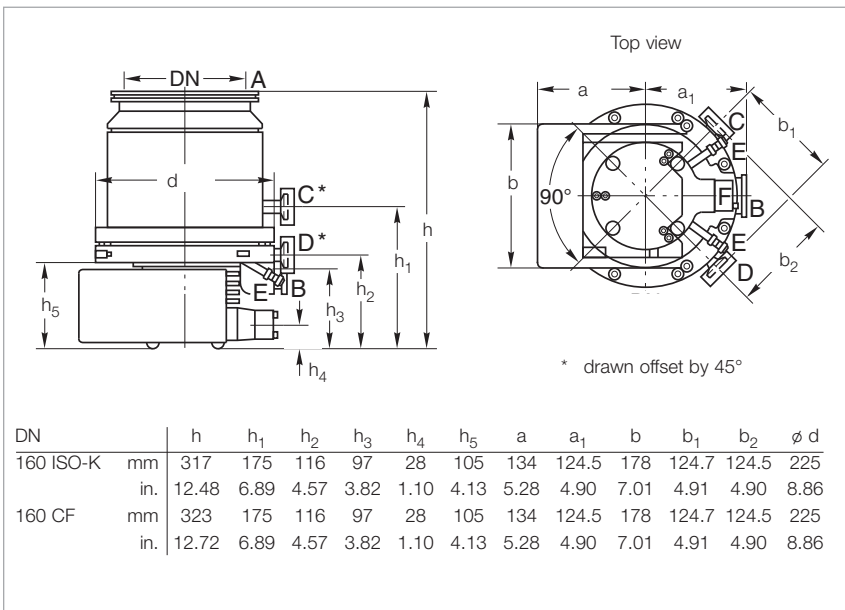

Dimensional drawing for the TURBOVAC 600 C

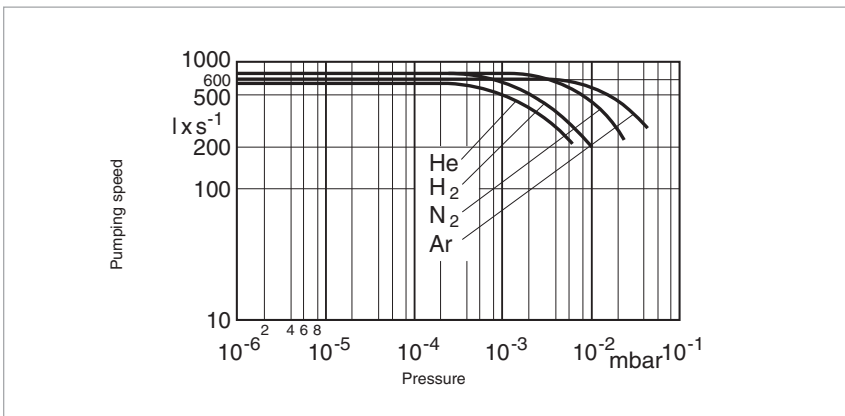

Pumping speed for different gases as a function of intake pressure (TURBOVAC 600 C with flange DN 160 ISO-K)

Advantages to the User

- Installation in any orientation
- Highly reliable due to hybrid ceramic ball bearings
- Life time lubrication and maintenance-free
- Option: Purge gas facility

Technical Data

TURBOVAC 600 C

Inlet flange	DN	160 ISO-K • 160 CF
Pumping speed		
N ₂	l x s ⁻¹	560
He	l x s ⁻¹	600
H ₂	l x s ⁻¹	570
Max. gas throughput		
N ₂	mbar x l x s ⁻¹	< 4
Ar	mbar x l x s ⁻¹	< 4
Compression ratio		
N ₂		> 10 ⁹
He		2 x 10 ⁴
H ₂		1.1 x 10 ³
Ultimate pressure	mbar (Torr)	< 10 ⁻¹⁰ (< 10 ⁻¹⁰)
Speed	min ⁻¹	36 000
Run-up time (frequency converter), approx.	min	4
Max. continuous inlet pressure ¹⁾ (continuous)	mbar (Torr)	1 x 10 ⁻² (0.75 x 10 ⁻²)
Max. foreline pressure for N ₂	mbar (Torr)	1 x 10 ⁻¹ (0.75 x 10 ⁻¹)
Recommended forevacuum pump for standard operation for purge gas operation		TRIVAC D 25 B / 40 B TRIVAC 40 B
Run-up time to 95% speed	min	3
Purge / vent port	DN	10 KF
Cooling water connection (hose nozzles)	mm (in.)	10 (0.39)
Weight, approx.	kg (lbs)	17 (37.5)
Max. power consumption	VA	680
at ultimate pressure	VA	480

¹⁾ Water-cooled

Ordering Information

TURBOVAC 600 C

Inlet flange	Foreline flange	Cooling method	Item	
DN 160 ISO-K	DN 40 KF	Water-cooled	TURBOVAC 600 C	Part No. 800150V0015
DN 160 CF	DN 40 KF	Water-cooled	TURBOVAC 600 C	Part No. 800150V0017
Accessories, necessary for all pumps				
Electronic frequency converter TURBO.DRIVE TD20 <i>classic</i> 100 - 240 V AC (-15%/+10%) without interface with RS 232 C interface with RS 485 C interface with Profibus with 25 pol I/O with DeviceNet with Ethernet/IP				Part No. 800075V0001 Part No. 800075V0002 Part No. 800075V0004 Part No. 800075V0003 Part No. 800075V0005 Part No. 800075V0006 Part No. 800075V0007
Connecting cable TURBO.DRIVE TD20 <i>classic</i> - pump 3 m (10.5 ft) 5 m (17.5 ft) 10 m (35.0 ft) 20 m (70.0 ft) 50 m (175.0 ft) 60 m (210.0 ft)				Part No. 857 65 Part No. 857 66 Part No. 857 67 Part No. 857 68 Part No. 800152V0008 Part No. 800152V0007
Accessories, optional				
Air cooling unit 230 V AC 115 V AC 100 V AC				Part No. 855 41 Part No. 170 016 Part No. 800152V0017
Flange heater 160 CF 230 V AC 110 V AC				Part No. 854 37 Part No. 854 38
Mains cable 3 m (10.5 ft) Euro plug UK plug US plug 6-15 P				Part No. 800102V0002 Part No. 800102V0003 Part No. 800102V1002

TURBOVAC 1000 C

ClassicLine



Typical Applications

- Evaporation and sputtering systems
- Metallurgy
- Research systems

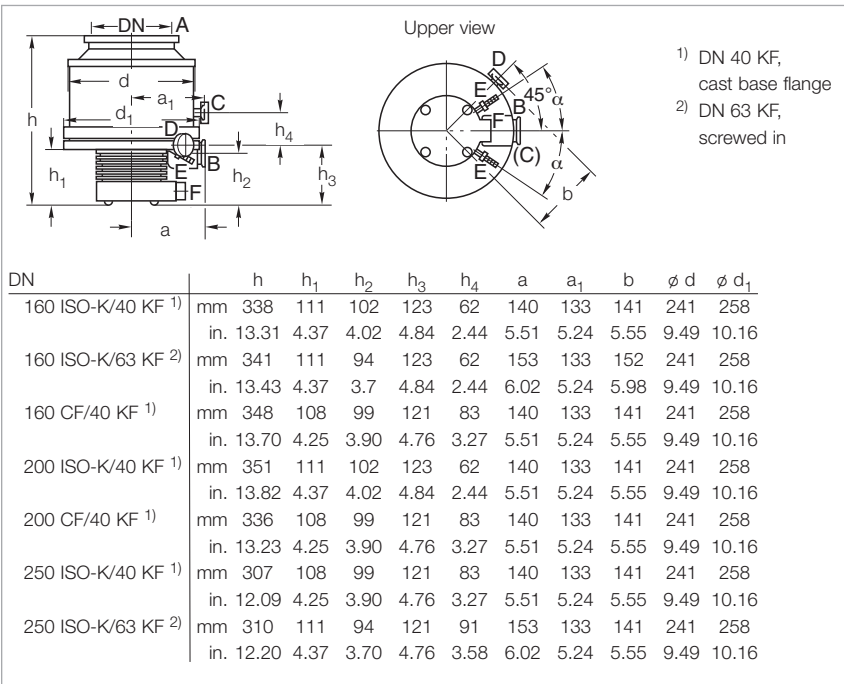

Dimensional drawing for the TURBOVAC 1000 C

Technical Features

- Robust rotor design
- Operation in any orientation
- Highest pumping speed and throughput

Advantages to the User

- Installation in any orientation
- Highly reliable due to hybrid ceramic ballbearings
- Standard model:
Venting flange, water cooling
- Options:
Air cooling, purge gas facility

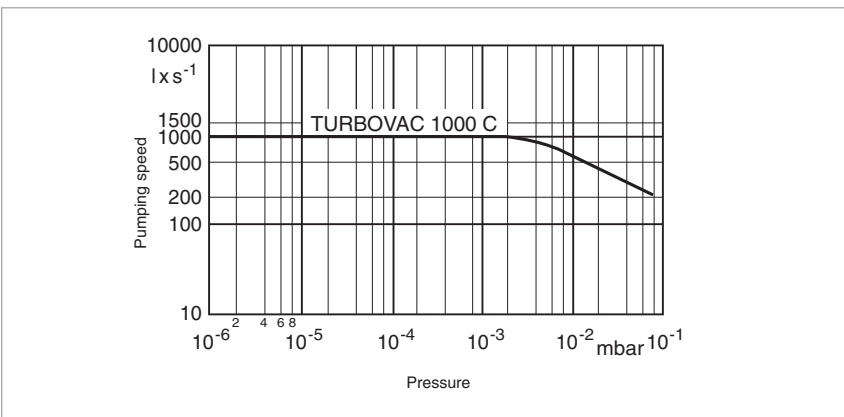

Pumping speed for air as a function of intake pressure (TURBOVAC 1000 C with DN 250 flange)

Technical Data

TURBOVAC 1000 C

Inlet flange	DN	160 ISO-K • 160 CF	200 ISO-K • 200 CF	250 ISO-K
Pumping speed				
N ₂	l x s ⁻¹	850	1100	1150
He	l x s ⁻¹	880	975	1000
H ₂	l x s ⁻¹	900	970	1000
Max. gas throughput				
N ₂	mbar · l x s ⁻¹	6.5	6.5	6.5
Compression ratio				
N ₂		> 10 ⁹	> 10 ⁹	> 10 ⁹
He		5 x 10 ⁴	5 x 10 ⁴	5 x 10 ⁴
H ₂		2 x 10 ³	2 x 10 ³	2 x 10 ³
Ultimate pressure				
	mbar (Torr)	< 10 ⁻¹⁰ (< 0.75 x 10 ⁻¹⁰)	< 10 ⁻¹⁰ (< 0.75 x 10 ⁻¹⁰)	< 10 ⁻¹⁰ (< 0.75 x 10 ⁻¹⁰)
Run-up time				
	min ⁻¹	36 000	36 000	36 000
Run-up time to 95% speed, approx.				
	min	9	9	9
Max. continuous inlet pressure ¹⁾ (continuous)				
	mbar (Torr)	1 x 10 ⁻² (0.75 x 10 ⁻²)	1 x 10 ⁻² (0.75 x 10 ⁻²)	1 x 10 ⁻² (0.75 x 10 ⁻²)
Type of bearing				
		Hybrid ceramic ball bearings	Hybrid ceramic ball bearings	Hybrid ceramic ball bearings
Type of lubrication				
		Fett	Fett	Fett
Installation orientation				
		Any	Any	Any
Cooling				
		Water (air)	Water (air)	Water (air)
Weight, approx.				
	kg (lbs)	25 (55.1)	25 (55.1)	25 (55.1)
Recommended backing pump				
for standard operation	TRIVAC	D 25 B / D 40 B	D 25 B / D 40 B	D 25 B / D 40 B
for purge gas operation	TRIVAC	D 40 B / D 65 B	D 40 B / D 65 B	D 40 B / D 65 B

¹⁾ Water-cooled

Ordering Information

TURBOVAC 1000 C

Inlet flange	Foreline flange	Cooling method	Interface	
DN 160 ISO-K	DN 40 KF	Water-cooled	-	Part No. 855 35
DN 160 ISO-K	DN 63 ISO-K	Water-cooled	-	Part No. 855 38
DN 200 ISO-K	DN 40 KF	Water-cooled	-	Part No. 153 00
DN 160 CF	DN 40 KF	Water-cooled	-	Part No. 854 91
DN 200 CF	DN 40 KF	Water-cooled	-	Part No. 117 64
DN 250 ISO-K	DN 40 KF	Water-cooled	-	Part No. 855 36
DN 250 ISO-K	DN 63 ISO-K	Water-cooled	-	Part No. 855 39
Accessories, necessary for all pumps				
Electronic frequency converter TURBO.DRIVE TD20 <i>classic</i> 100 - 240 V AC (-15%/+10%) without interface with RS 232 C interface with RS 485 C interface with Profibus with 25 pol I/O with DeviceNet with Ethernet/IP				Part No. 800075V0001 Part No. 800075V0002 Part No. 800075V0004 Part No. 800075V0003 Part No. 800075V0005 Part No. 800075V0006 Part No. 800075V0007
Connecting cable TURBO.DRIVE TD20 <i>classic</i> - pump 3 m (10.5 ft) 5 m (17.5 ft) 10 m (35.0 ft) 20 m (70.0 ft) 50 m (175.0 ft) 60 m (210.0 ft)				Part No. 857 65 Part No. 857 66 Part No. 857 67 Part No. 857 68 Part No. 800152V0008 Part No. 800152V0007
Accessories, optional				
Air cooling unit 230 V AC 115 V AC 100 V AC				Part No. 855 41 Part No. 894 09 Part No. 800152V0017
Purge / vent valve, DN 16 KF 24 V DC; $0.6 \text{ mbar} \times \text{l} \times \text{s}^{-1} = 36 \text{ sccm}$				Part No. 121 33
Mains cable 3 m (10.5 ft) Euro plug UK plug US plug 6-15 P				Part No. 800102V0002 Part No. 800102V0003 Part No. 800102V1002

TURBOVAC 1100 C

ClassicLine



Typical Applications

- Data storage
- Flat panel displays
- Optical coating
- Large area coating
- R & D, e.g.
 - Fusion experiments
 - Space simulation
- Load locks and transfer chambers

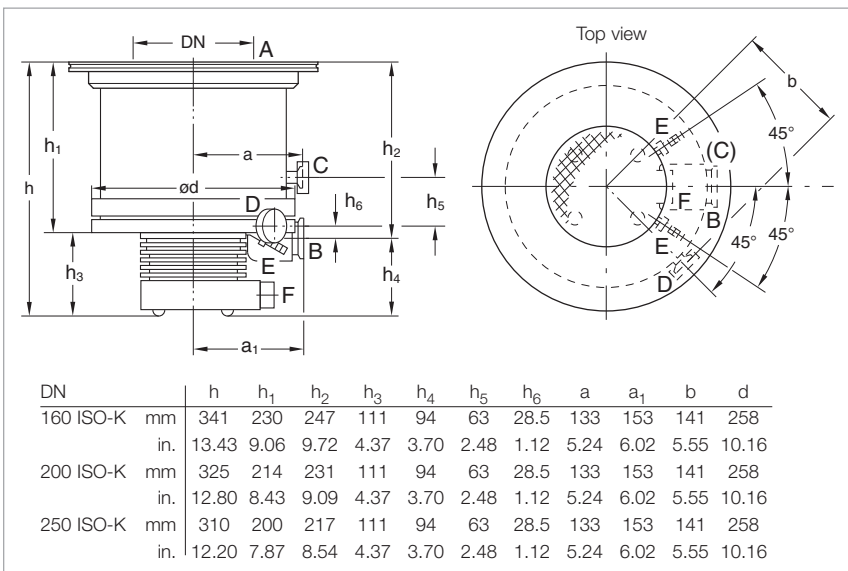

Dimensional drawing for the TURBOVAC 1100 C

Technical Features

- Robust rotor design
- Operation in any orientation
- Highest pumping speed and throughput
- Bearing temperature measurement through the TURBO.DRIVE TD20 *classic*
- Oil-free pump for generating clean high and ultrahigh vacuum conditions

Advantages to the User

- Space-saving
- Easy to integrate into complex vacuum systems
- High productivity
- Low operating costs
- Highly reliable operation also in processes loaded with particles

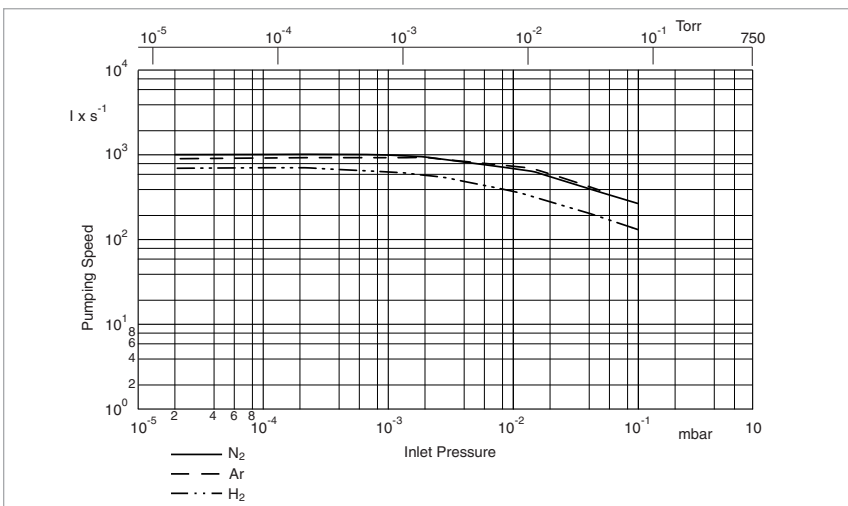

Pumping speed as a function of the inlet pressure (TURBOVAC 1100 C with flange DN 250)

Technical Data

TURBOVAC 1100 C

Inlet flange	DN	160 ISO-K	200 ISO-K	250 ISO-K
Pumping speed				
N ₂	l x s ⁻¹	710	830	1050
Ar	l x s ⁻¹	–	760	980
He	l x s ⁻¹	–	750	850
H ₂	l x s ⁻¹	–	600	630
Max. gas throughput				
N ₂	mbar x l x s ⁻¹	6.5	6.5	6.5
Ar	mbar x l x s ⁻¹	6.5	6.5	6.5
Compression ratio				
N ₂		1 x 10 ⁵	1 x 10 ⁵	1 x 10 ⁵
Ar		1 x 10 ⁵	1 x 10 ⁵	1 x 10 ⁵
H ₂		1 x 10 ⁴	1 x 10 ⁴	1 x 10 ⁴
Ultimate pressure	mbar (Torr)	< 3 x 10 ⁻¹⁰ (< 2.2 x 10 ⁻¹⁰)	< 3 x 10 ⁻¹⁰ (< 2.2 x 10 ⁻¹⁰)	< 3 x 10 ⁻¹⁰ (< 2.2 x 10 ⁻¹⁰)
Max. foreline pressure for N ₂	mbar (Torr)	0.1 (0.075)	0.1 (0.075)	0.1 (0.075)
Recommended forevacuum pump		TRIVAC D 65 B / SCROLLVAC SC 15/30 D	TRIVAC D 65 B / SCROLLVAC SC 15/30 D	TRIVAC D 65 B / SCROLLVAC SC 15/30 D
Run-up time to 95% speed	min	9	9	9
Purge / vent port	DN	10 KF	10 KF	10 KF
Cooling water connection (hose nozzles)	mm (in.)	10 (0.39)	10 (0.39)	10 (0.39)
Weight, approx.	kg (lbs)	22 (48)	22 (48)	22 (48)
Supply voltage	V AC	42	42	42
Max. power consumption	VA	400	400	400

Ordering Information

TURBOVAC 1100 C

Inlet flange	Foreline flange	Cooling method	Interface	
DN 160 ISO-K	DN 63 ISO-K	Water-cooled	-	Part No. 800150V0030
DN 200 ISO-K	DN 63 ISO-K	Water-cooled	-	Part No. 800150V0031
DN 250 ISO-K	DN 63 ISO-K	Water-cooled	-	Part No. 800150V0032
Accessories, necessary for all pumps				
Electronic frequency converter TURBO.DRIVE TD20 <i>classic</i> 100 - 240 V AC (-15%/+10%) without interface with RS 232 C interface with RS 485 C interface with Profibus with 25 pol I/O with DeviceNet with Ethernet/IP				Part No. 800075V0001 Part No. 800075V0002 Part No. 800075V0004 Part No. 800075V0003 Part No. 800075V0005 Part No. 800075V0006 Part No. 800075V0007
Connecting cable TURBO.DRIVE TD20 <i>classic</i> - pump 3 m (10.5 ft) 5 m (17.5 ft) 10 m (35.0 ft) 20 m (70.0 ft) 50 m (175.0 ft) 60 m (210.0 ft)				Part No. 857 65 Part No. 857 66 Part No. 857 67 Part No. 857 68 Part No. 800152V0008 Part No. 800152V0007
Accessories, optional				
Purge / vent valve, DN 16 KF 24 V DC; 0.6 mbar x l x s ⁻¹ = 36 sccm				Part No. 121 33

Note: The TURBO.GUARD 3 system is no longer available for these part numbers and is not supported by the TURBO.DRIVE TD20 *classic*.

Note for the North and South American Continents: For special application we recommend the TURBOVAC 1000 C. Please contact your sale office

TURBOVAC T 1600 / T 1601



Typical Applications

- Data storage
- Flat panel displays
- Optical coating
- Large area coating
- R & D, e.g.
 - Fusion experiments
 - Space simulation

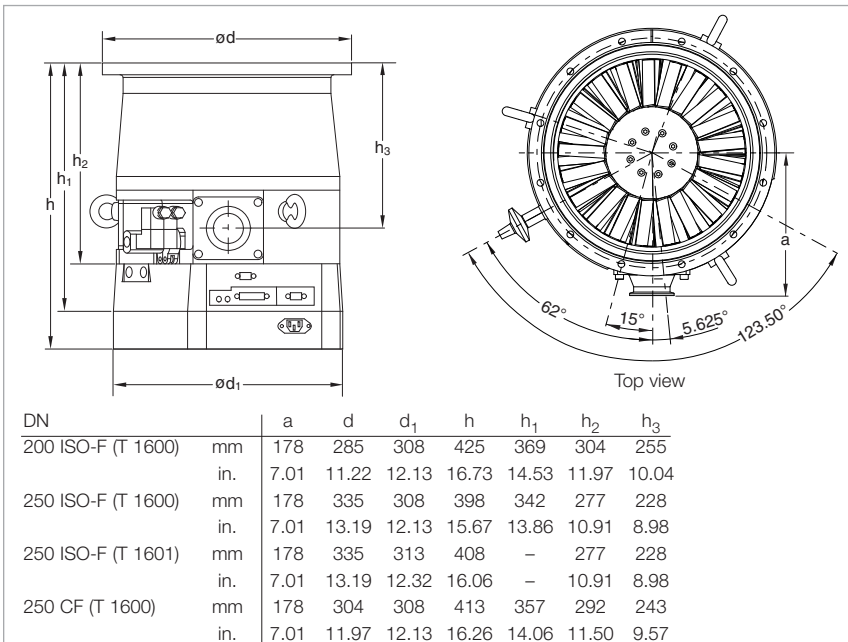

Dimensional drawing for the TURBOVAC T 1600

Technical Features

- Frequency converter and power supply integrated
- Robust rotor design
- Operation in any orientation
- Highest pumping speed and throughput
- Oil-free pump for generating clean high and ultrahigh vacuum conditions
- Purge gas and venting valve integrated
- For special outside influences (only T 1601)

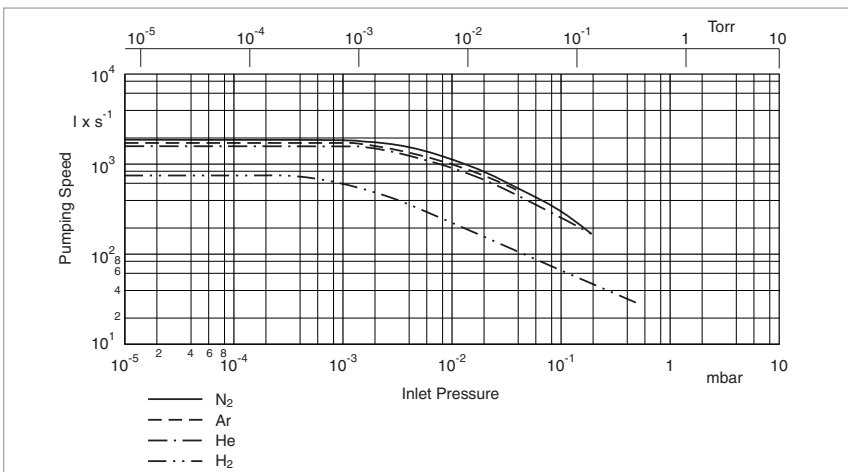

Pumping speed as a function of the inlet pressure (TURBOVAC T 1600 with flange DN 250)

Advantages to the User

- Space-saving
- Easy to integrate into complex vacuum systems
- High productivity
- Low operating costs
- Highly reliable operation also in processes loaded with particles

Technical Data

TURBOVAC T 1600 / T 1601

Inlet flange	DN	200 ISO-F	250 ISO-F • 250 CF
Pumping speed			
N ₂	l x s ⁻¹	1100	1550
Ar	l x s ⁻¹	960	1410
He	l x s ⁻¹	1150	1300
H ₂	l x s ⁻¹	690	720
Max. gas throughput			
N ₂	mbar x l x s ⁻¹	30	30
Ar	mbar x l x s ⁻¹	20	20
He	mbar x l x s ⁻¹	30	30
H ₂	mbar x l x s ⁻¹	20	20
Compression ratio			
N ₂		5 x 10 ⁵	5 x 10 ⁵
Ar		1 x 10 ⁶	1 x 10 ⁶
He		1 x 10 ⁴	1 x 10 ⁴
H ₂		2 x 10 ²	2 x 10 ²
Ultimate pressure	mbar (Torr)	< 3 x 10 ⁻¹⁰ (< 2.2 x 10 ⁻¹⁰)	< 3 x 10 ⁻¹⁰ (< 2.2 x 10 ⁻¹⁰)
Max. foreline pressure for N ₂	mbar (Torr)	0.5 (0.375)	0.5 (0.375)
Recommended forevacuum pump (alternatively)		TRIVAC D 65 B + RUVAC WA 501 TRIVAC D 65 B SCROLLVAC SC 15/30 D	TRIVAC D 65 B + RUVAC WA 501 TRIVAC D 65 B SCROLLVAC SC 15/30 D
Run-up time to 95% speed	min	< 10	< 10
Purge / vent port	DN	G 1/4"	G 1/4"
Cooling water connection		G 3/8"	G 3/8"
Weight, approx.	kg (lbs)	40 (88)	40 (88)
Supply voltage	V	100 - 240	100 - 240
Max. power consumption	VA	700	700

Ordering Information

TURBOVAC T 1600

Inlet flange	Foreline flange	Cooling method	Interface	
DN 200 ISO-F	DN 40 KF	Water-cooled	-	Part No. 800040V1144 Part No. 800040V2144 Part No. 800040V1444 Part No. 800040V2444 Part No. 800040V1544 Part No. 800040V1844 Part No. 800040V2844
DN 200 ISO-F	DN 40 KF	Water-cooled	Profibus	
DN 250 ISO-F	DN 40 KF	Water-cooled	-	
DN 250 ISO-F	DN 40 KF	Water-cooled	Profibus	
DN 250 ISO-F	DN 63 ISO-K	Water-cooled	-	
DN 250 CF	DN 40 KF	Water-cooled	-	
DN 250 CF	DN 40 KF	Water-cooled	Profibus	
Purge filter				
Accessories for RS 232 C and RS 485 C interfaces				see chapter "Turbomolecular Pumps", para. "Accessories"

Ordering Information

TURBOVAC T 1601

Inlet flange	Foreline flange	Cooling method	Interface	
DN 250 ISO-F	DN 40 KF	Water-cooled	Profibus	Part No. 800040V4444
Accessories for RS 232 C and RS 485 C interfaces				see chapter "Turbomolecular Pumps", para. "Accessories"

Mechanical Rotor Suspension with Compound Stage TURBOVAC TW 70 H



Typical Applications

- Mass spectrometers
- Electron beam microscopy
- Leak detectors
- R & D, e.g.
 - UHV systems
- Load locks and transfer chambers

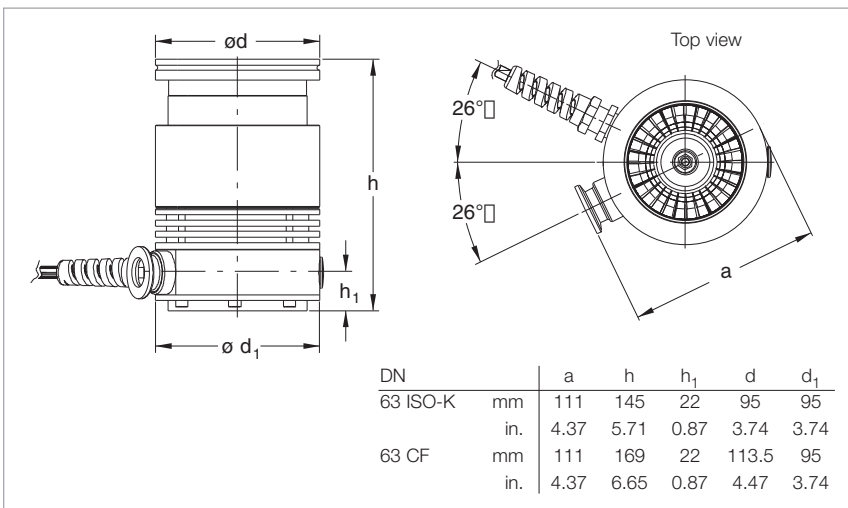

Dimensional drawing for the TURBOVAC TW 70 H

Technical Features

- Integrated or external frequency converter
- Compact design
- Operation in any orientation
- High foreline tolerance
- Oil-free pump for generating clean high and ultrahigh vacuum conditions

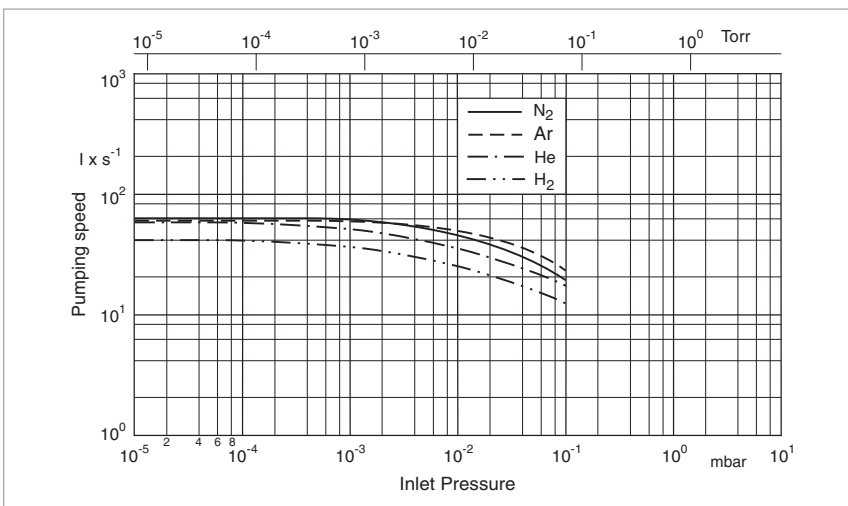

Pumping speed as a function of the inlet pressure

Advantages to the User

- Space-saving
- Easy to integrate into complex vacuum systems
- Allows the use of down-sized forevacuum pumps
- Low operating costs
- Highly reliable operation

Technical Data

TURBOVAC TW 70 H

Inlet flange	DN	O-ring sealed 63 ISO-K	Metal sealed 63 CF
Pump housing		Aluminum	Stainless steel
Pumping speed at $10^{-5} / 10^{-3}$ mbar			
N ₂	l x s ⁻¹	60 / 56	60 / 56
Ar	l x s ⁻¹	56 / 54	56 / 54
H ₂	l x s ⁻¹	40 / 38	40 / 38
He	l x s ⁻¹	52 / 50	52 / 50
Max. gas throughput ¹⁾ at 10^{-1} mbar			
N ₂	mbar x l x s ⁻¹	1.9	1.9
Ar	mbar x l x s ⁻¹	2.4	2.4
H ₂	mbar x l x s ⁻¹	1.3	1.3
He	mbar x l x s ⁻¹	1.9	1.9
Max. compression when idle			
N ₂		1×10^8 at 14 mbar	1×10^{10} at 10 mbar
Ar		1×10^7 at 14 mbar	
H ₂		4×10^3 at 0.2 mbar	
He		2×10^5 at 2 mbar	
Ultimate pressure			
with two-stage oil-sealed rotary vane vacuum pump TRIVAC D 2,5 E	mbar (Torr)	$< 5 \times 10^{-8}$ ($< 3.75 \times 10^{-8}$)	$< 2 \times 10^{-10}$ ($< 1.5 \times 10^{-10}$)
with dry compressing scroll vacuum pump SCROLLVAC SC 5 D	mbar (Torr)		$< 1 \times 10^{-9}$ ($< 0.75 \times 10^{-9}$)
with diaphragm pump DIVAC 0.8 T	mbar (Torr)		$< 5 \times 10^{-9}$ ($< 3.75 \times 10^{-9}$)
Max. foreline pressure for N ₂	mbar (Torr)	20 (15)	20 (15)
Recommended forevacuum pump			
two-stage oil-sealed rotary vane vacuum pump		TRIVAC D 2,5 E	TRIVAC D 2,5 E
diaphragm pump		DIVAC 0,8 T	DIVAC 0,8 T
oil-free scroll vacuum pump		SC 5 D	SC 5 D
Run-up time to 95% of nominal speed	min	1.5	1.5
Cooling water connection (option)		2 x G 1/8"	2 x G 1/8"
Weight, approx. with / without frequency converter	kg (lbs)	3.0 (6.62) / 2.3 (5.08)	3.0 (6.62) / 2.3 (5.08)
Supply voltage	V DC	24	24
Max. power consumption			
Run up / ultimate pressure	W	150 / 30	150 / 30

¹⁾ for continuous operation when water-cooled

Ordering Information

TURBOVAC TW 70 H

TW 70 H with integrated frequency converter TURBO.DRIVE S				
Inlet flange	Foreline flange	Cooling method	Interface	
DN 63 ISO-K	DN 16 KF	Air-cooled	RS 485 C	Part No. 800002V1235
DN 63 ISO-K	DN 16 KF	Air-cooled	RS 232 C	Part No. 800002V1236
DN 63 ISO-K	DN 16 KF	Water-cooled	RS 485 C	Part No. 800002V1435
DN 63 ISO-K	Camozzi coupling ¹⁾	Air-cooled	RS 485 C	Part No. 800002V1215
DN 63 ISO-K	Camozzi coupling ¹⁾	Water-cooled	RS 485 C	Part No. 800002V1415
DN 63 CF	DN 16 KF	Air-cooled	RS 232 C	Part No. 800002V2236
DN 63 CF	DN 16 KF	Water-cooled	RS 485 C	Part No. 800002V2435
TW 70 H without frequency converter TURBO.DRIVE S				
Inlet flange	Foreline flange	Cooling method	Interface	
DN 63 ISO-K	DN 16 KF	Convection	-	Part No. 800002V1934
DN 63 ISO-K	DN 16 KF	Air-cooled	-	Part No. 800002V1234
DN 63 ISO-K	Camozzi coupling ¹⁾	Convection	-	Part No. 800002V1914
DN 63 CF	DN 16 KF	Convection	-	Part No. 800002V2934
For operation, one frequency converter TURBO.DRIVE S is necessary				
Electronic frequency converter TURBO.DRIVE S with heat sink				
RS 485 C interface				Part No. 800070V0006
RS 232 C interface				Part No. 800070V0005
Connecting cable (TURBO.DRIVE S - pump)				
1 m (3.5 ft)				Part No. 152 47
3 m (10.5 ft)				Part No. 864 40
5 m (17.5 ft)				Part No. 864 50
Accessories, necessary for all pumps				
START/STOP switch for manual operation of the turbomolecular pump				Part No. 152 48
Power supplies				see chapter
TURBO.POWER 300				“Turbomolecular Pumps
TURBO.CONTROL 300				with Mechanical Rotor Suspension”,
				para. “Electronic Frequency Converters”
Accessories, optional				
Water cooling unit with 2 x G 1/8" connection				
including 2 hose nozzles G 1/8", OD 8 mm for water hose,				
2 gaskets (copper) 10 x 14 x 1				Part No. 800135V0001
Air cooling unit (uses V DC from pump connection)				Part No. 800136V0001
Flange heater 63 CF				
230 V, 50 Hz				Part No. 854 04
110 V, 60 Hz				Part No. 854 07
Splinter guard				
DN 63 ISO-K (coarse)				Part No. 200 17 170
DN 63 CF (coarse)				Part No. 200 17 171
DN 63 CF (fine)				Part No. 887 20
Vibration absorber				
DN 63 ISO-K				Part No. 800131V0063
DN 63 CF				Part No. 500 070
Accessories for serial interfaces RS 232 C and RS 485 C				see chapter “Turbomolecular Pumps”, para. “Accessories”

¹⁾ Quick coupling for plastic vacuum hoses with an OD of 10 mm. We recommend polyamide hoses

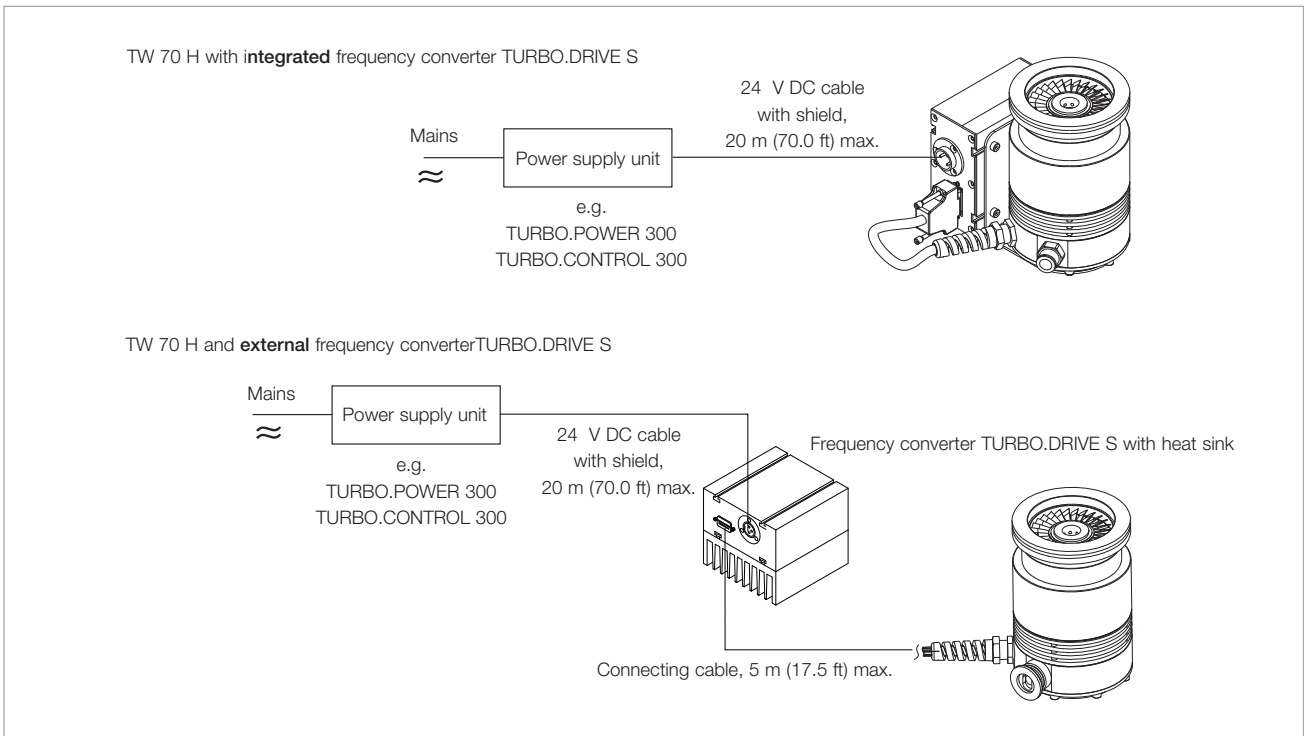

The modular concept

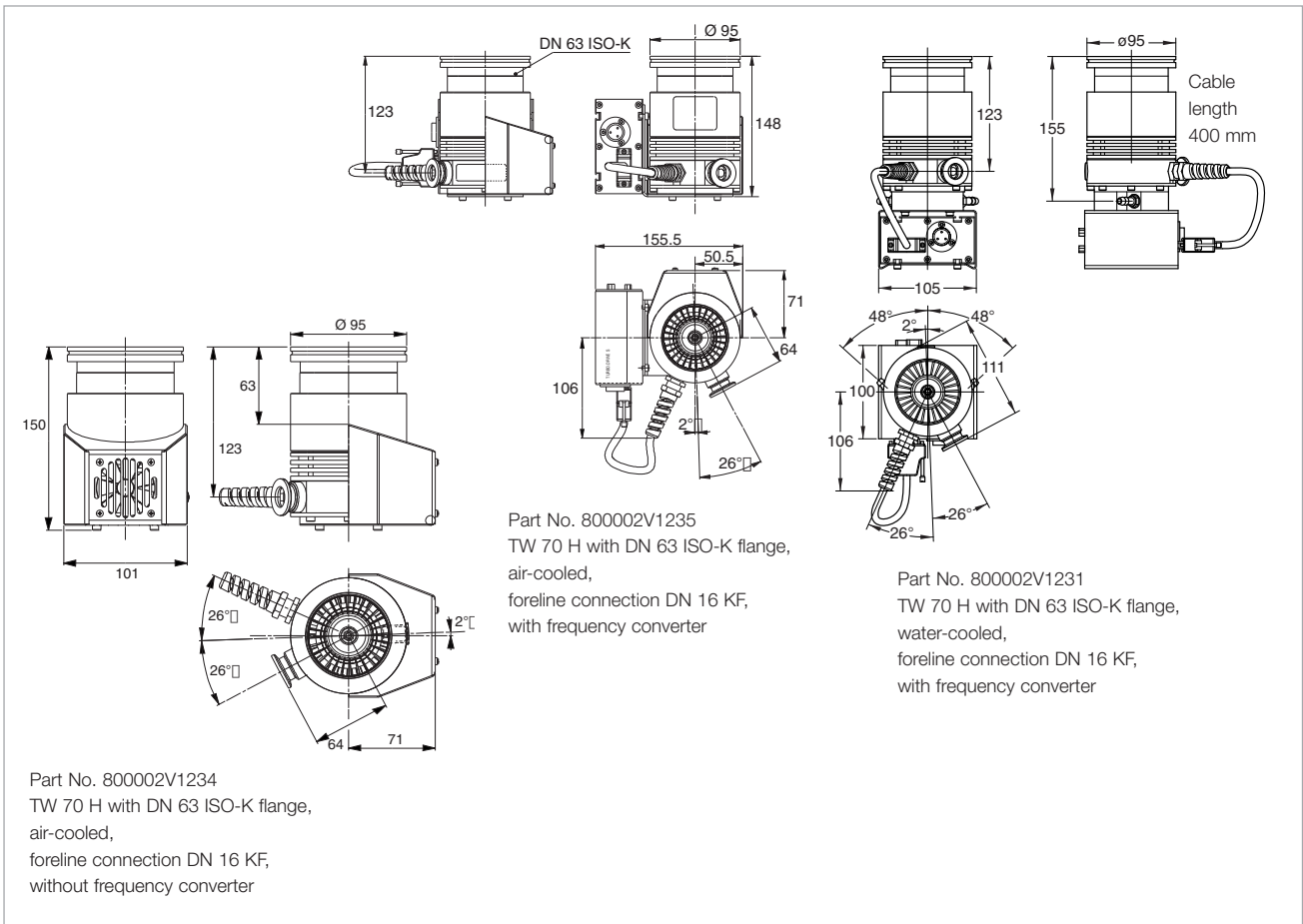

Selected dimensional drawings for the TURBOVAC TW 70 H versions

TURBOVAC TW 250 S



Typical Applications

- Analytical instruments
- Coating
- R & D

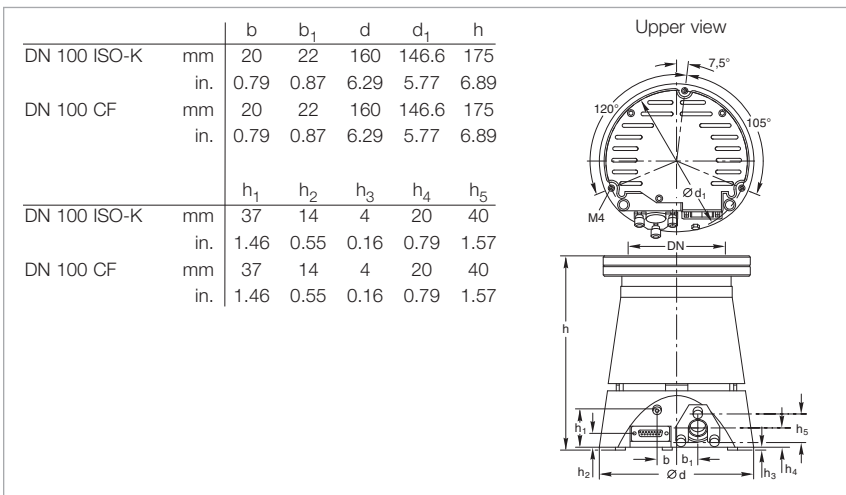

Dimensional drawing for the TURBOVAC TW 250 S without frequency converter

Technical Features

- Integrated or external frequency converter
- Compact design
- Efficient air-cooling system integrated

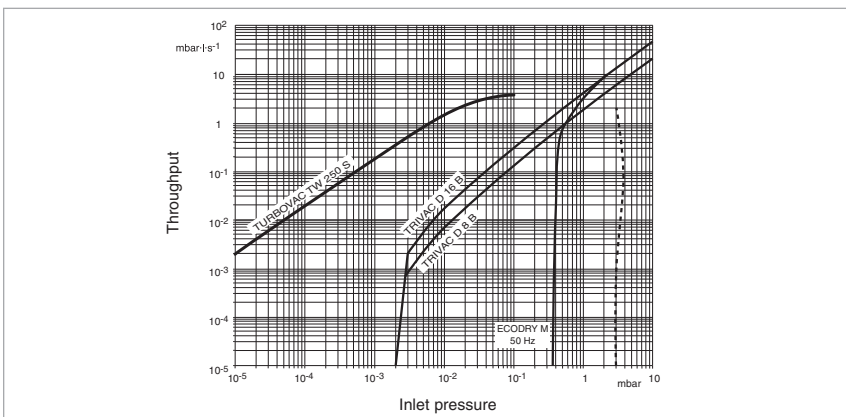

Operation diagram for nitrogen for TURBOVAC TW 250 S

Advantages to the User

- Highest pumping speed and throughput for N₂ and Ar
- Highest reliability in operation

Technical Data

TURBOVAC TW 250 S

Inlet flange	DN	100 ISO-K / 100 CF
Pumping speed at 10^{-5} mbar		
N ₂	l x s ⁻¹	230
Ar	l x s ⁻¹	210
H ₂	l x s ⁻¹	80
He	l x s ⁻¹	150
Max. gas throughput, max.		
N ₂		3.7 mbar x l x s ⁻¹ at 10 ⁻¹ mbar
Ar		1.6 mbar x l x s ⁻¹ at 10 ⁻² mbar
H ₂		1.1 mbar x l x s ⁻¹ at 10 ⁻¹ mbar
He		2.4 mbar x l x s ⁻¹ at 10 ⁻¹ mbar
Compression ratio		
N ₂		3.0 x 10 ⁷ at 3 mbar
Ar		1.0 x 10 ⁷ at 6 mbar
H ₂		5.0 x 10 ² at 0.2 mbar
He		3.2 x 10 ³ at 0.7 mbar
Ultimate pressure with two-stage oil-sealed rotary vane pump	mbar (Torr)	< 2 x 10 ⁻⁸ (< 1.5 x 10 ⁻²)
Max. permissible backing pressure for N ₂	mbar (Torr)	3 (2.25)
Operating speed	min ⁻¹ (rpm)	51.600
Run-up time, approx.	min	3
Forevacuum connection		DN 16 KF
Venting connection		Thread M 5
Weight		
without frequency converter	kg (lbs)	5.0 (11.0)
with frequency converter	kg (lbs)	5.8 (12.6)
Recommended forevacuum pumps		
TRIVAC		D 2.5 E
Diaphragm pump		
with an ultimate pressure < 3 mbar		
and a pumping speed at 3 mbar		upon request
TRIVAC (at purge gas operation)		D 8 B

Ordering Information

TURBOVAC TW 250 S

TURBOVAC TW 250 S with integrated frequency converter TDS				
Inlet flange	Cooling method	Splinter guard	Frequency converter	
DN 100 ISO-K	Water-cooled	–	TDS / PB	Part No. 114 37
DN 100 ISO-K	Water-cooled	Course	TDS / PB	Part No. 800150V0016
DN 100 ISO-K	Air-cooled	Course	TDS / PB	Part No. 800150V0009
DN 100 ISO-K	Air-cooled	–	TDS / RS 232 C	Part No. 800150V0011
DN 100 ISO-K	Air-cooled	–	TDS / RS 485 C	Part No. 800150V0013
DN 100 CF	Air-cooled	–	TDS / RS 232 C	Part No. 800150V0012
DN 100 CF	Air-cooled	–	TDS / RS 485 C	Part No. 800150V0014
TURBOVAC TW 250 S without integrated frequency converter TDS				
Inlet flange	Cooling method	Splinter guard	Frequency converter	
DN 100 ISO-K	Air-cooled	Course	–	Part No. 113 52
DN 100 ISO-K	Air-cooled	Course	–	Part No. 800150V0007
For operation, one frequency converter TDS is necessary Electronic frequency converter TDS without heat sink with RS 485 C interface with RS 232 C interface				Part No. 800070V0003 Part No. 800070V0002
Connecting cable TDS – pump 1 m (3.5 ft)				Part No. 152 47
Power supplies TURBO.POWER 300 TURBO.CONTROL 300				see chapter “Turbomolecular Pumps with Mechanical Rotor Suspension”, para. “Electronic Frequency Converters”
Accessories, optional				
Venting valve mounting kit				Part No. 863 20
Venting valve 220/240 V AC 110/120 V AC 24 V DC				Part No. 280 70 Part No. E 280 72 Part No. E 280 74
Water cooling unit with 2x G 1/8" connection including 2 hose nozzles G 1/8", OD 10 mm for water hose, 4 gaskets, 2 blank-off plugs				Part No. 800135V0002
Air cooling unit (uses V DC from pump connection)				Part No. 800 000 249
Flange heater 100 CF, 230 V, 50 Hz 100 CF, 110 V, 60 Hz				Part No. 854 27 Part No. 854 28
Splinter guard DN 100 ISO-K/CF coarse (3.2 x 3.2 mm (0.13 x 0.13 in.)) fine (1.6 x 1.6 mm (0.06 x 0.06 in.)) DN 160 ISO-K DN 160 CF				Part No. 800132V0101 Part No. 800132V0102 Part No. 200 00 307 Part No. 200 17 247
Vibration absorber DN 100 ISO-K DN 100 CF DN 160 ISO-K DN 160 CF				Part No. 800131V0100 Part No. 500 071 Part No. 500 073 Part No. 500 072
Accessories for serial interfaces RS 232 C and RS 485 C				see chapter “Turbomolecular Pumps”, para. “Accessories”

TURBOVAC TW 290 H



Typical Applications

- Mass spectrometers
- R & D, e.g.
 - UHV systems
 - Particle accelerators
- Load locks and transfer chambers

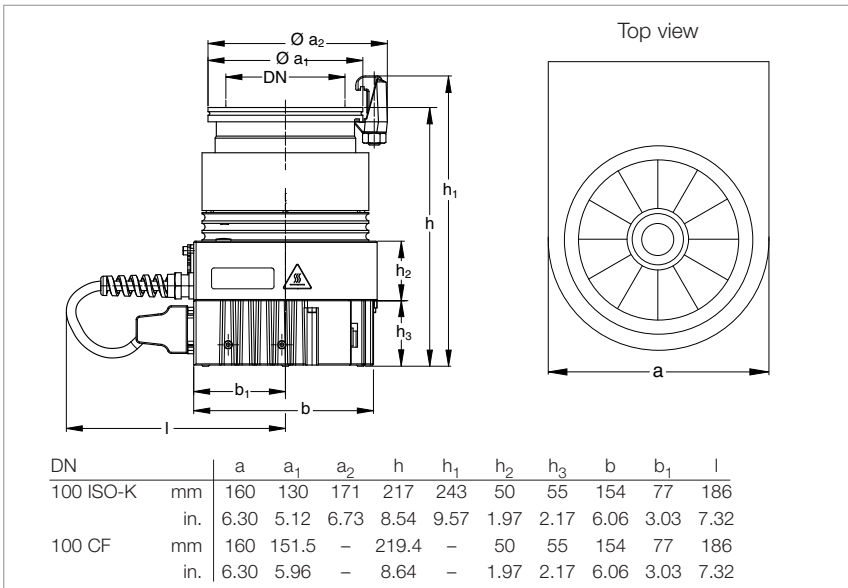

Dimensional drawing for the TURBOVAC TW 290 H

Technical Features

- Integrated frequency converter
- Compact design
- Operation in any orientation
- High pumping speed and compression for light gases
- Highly effective air-cooling unit
- Oil-free pump for generating clean high and ultrahigh vacuum conditions

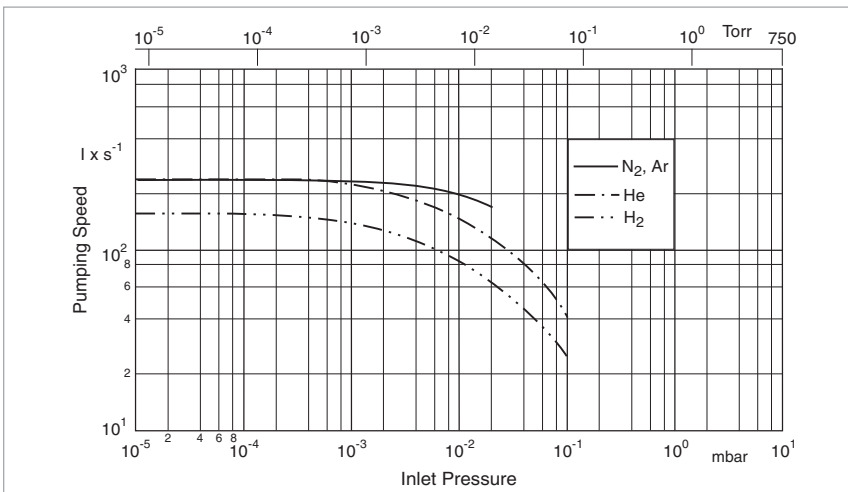

Pumping speed as a function of the inlet pressure

Advantages to the User

- Space-saving
- Easy to integrate into complex vacuum systems
- High foreline tolerance allows the use of down-sized forevacuum pumps
- Low operating costs

Technical Data

TURBOVAC TW 290 H

Inlet flange	DN	O-ring sealed 100 ISO-K	Metal sealed 100 CF
Pump housing		Aluminum	Stainless steel
Pumping speed at $10^{-5} / 10^{-3}$ mbar			
N ₂	l x s ⁻¹	240 / 240	240 / 240
Ar	l x s ⁻¹	240 / 240	240 / 240
H ₂	l x s ⁻¹	160 / 140	160 / 140
He	l x s ⁻¹	240 / 230	240 / 230
Ultimate pressure (for CF pumps)			
with two-stage oil-sealed rotary vane vacuum pump			
TRIVAC D 2,5 E	mbar (Torr)	$< 1 \times 10^{-8}$ ($< 0.75 \times 10^{-8}$)	$< 1 \times 10^{-10}$ ($< 0.75 \times 10^{-10}$)
with dry compressing scroll vacuum pump			
SCROLLVAC SC 15 D	mbar (Torr)		$< 1 \times 10^{-9}$ ($< 0.75 \times 10^{-9}$)
with diaphragm pump			
DIVAC 2.5 VT	mbar (Torr)		$< 1 \times 10^{-9}$ ($< 0.75 \times 10^{-9}$)
Max. foreline pressure for N ₂ ¹⁾	mbar (Torr)	< 6	< 6
Recommended forevacuum pump			
two-stage oil-sealed rotary vane vacuum pump		TRIVAC D 2,5 E	TRIVAC D 2,5 E
dry compressing scroll vacuum pump		SCROLLVAC SC 15 D	SCROLLVAC SC 15 D
Run-up time to 95% of nominal speed	min	4	4
Purge / vent port	DN	16 KF	16 KF
Cooling water connection (option)		2x G 1/8"	2x G 1/8"
Weight, approx. with / without frequency converter	kg (lbs)	6.8 (15.0) / 6.0 (13.2)	6.8 (15.0) / 6.0 (13.2)
Supply voltage	V DC	24	24
Max. power consumption			
Run up / ultimate pressure	W	150 / 30	150 / 30

¹⁾ water-cooled

Ordering Information

TURBOVAC TW 290 H

TW 290 H with integrated frequency converter TD 300				
Inlet flange	Foreline flange	Cooling method	Interface	Part No. 800170V3003 Part No. 800170V3004
DN 100 ISO-K	DN 16 KF	Convection	RS 485 C	
DN 100 CF	DN 16 KF	Convection	RS 485 C	
TW 290 H without frequency converter TD 300				
Inlet flange	Foreline flange	Cooling method	Interface	Part No. 800170V3001 Part No. 800170V3002
DN 100 ISO-K	DN 16 KF	Convection	-	
DN 100 CF	DN 16 KF	Convection	-	
Accessories, necessary for all pumps				
START/STOP switch for manual operation of the turbomolecular pump				Part No. 152 48
Power supplies TURBO.POWER 300 TURBO.CONTROL 300				see chapter "Turbomolecular Pumps with Mechanical Rotor Suspension", para. "Electronic Frequency Converters"
Accessories, optional				
Water cooling unit with G 1/8" connection including 2 hose nozzles G 1/8", OD 10 mm for water hose, 4 gaskets, 2 blank-off plugs				Part No. 800135V0002
Air cooling unit (uses V DC from pump connection)				Part No. 800 000 249
Flange heater 100 CF, 230 V, 50 Hz 100 CF, 110 V, 60 Hz				Part No. 854 27 Part No. 854 28
Splinter guard DN 100 ISO-K/CF coarse (3.2 x 3.2 mm (0.13 x 0.13 in.)) fine (1.6 x 1.6 mm (0.06 x 0.06 in.))				Part No. 800132V0101 Part No. 800132V0102
Vibration absorber DN 100 ISO-K DN 100 CF				Part No. 800131V0100 Part No. 500 071
Accessories for serial interfaces RS 232 C and RS 485 C				see chapter "Turbomolecular Pumps", para. "Accessories"

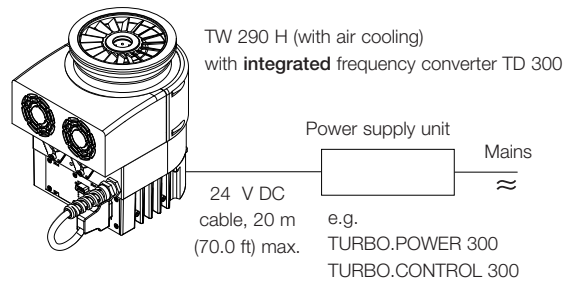
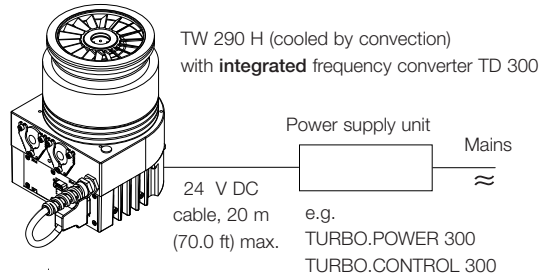

The modular concept

TURBOVAC TW 701



Typical Applications

- Mass spectrometers
- Data storage
- Flat panel displays
- R & D, e.g.
 - UHV systems
 - Particle accelerators
- Load locks and transfer chambers

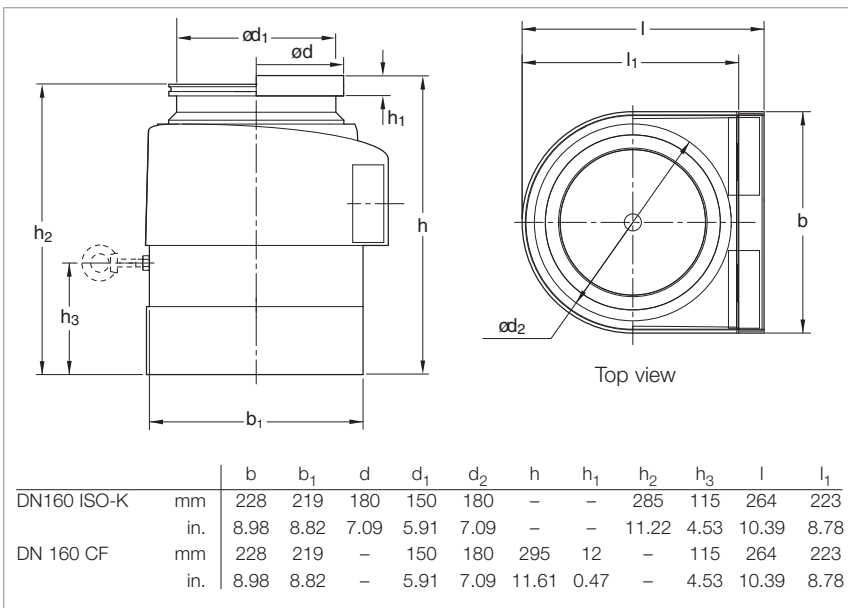

Dimensional drawing for the TURBOVAC TW 701

Technical Features

- Integrated frequency converter
- Operation in any orientation
- Highest pumping speed and throughput für Nitrogen und Argon
- High foreline tolerance allows the use of down-sized forevacuum pumps
- Highly effective air-cooling unit
- Oil-free pump for generating clean high and ultrahigh vacuum conditions

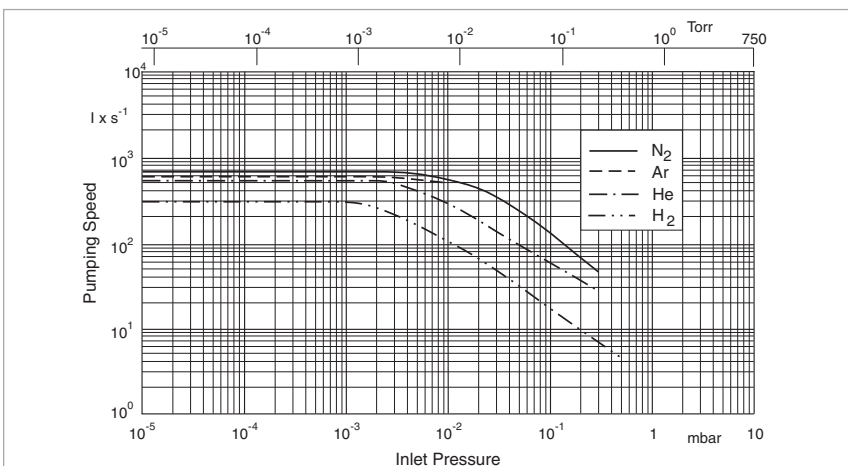

Pumping speed as a function of the inlet pressure

Advantages to the User

- Space-saving
- Easy to integrate into complex vacuum systems
- High productivity
- Low operating costs
- Highly reliable operation

Technical Data

TURBOVAC TW 701

Inlet flange	DN	160 ISO-K	160 CF
Pumping speed			
N ₂	l x s ⁻¹	680	680
Ar	l x s ⁻¹	600	600
He	l x s ⁻¹	530	530
H ₂	l x s ⁻¹	330	330
Max. gas throughput			
N ₂	mbar x l x s ⁻¹	12	12
Ar	mbar x l x s ⁻¹	5 (water-cooled)	5 (water-cooled)
He	mbar x l x s ⁻¹	7	7
H ₂	mbar x l x s ⁻¹	2.5	2.5
Compression ratio			
N ₂		8 x 10 ⁸	8 x 10 ⁸
Ar		1 x 10 ⁸	1 x 10 ⁸
He		1 x 10 ⁶	1 x 10 ⁶
H ₂		2 x 10 ⁴	2 x 10 ⁴
Ultimate pressure	mbar (Torr)	< 5.0 x 10 ⁻⁹ (< 3.75 x 10 ⁻⁹)	< 1.5 x 10 ⁻¹⁰ (< 1.1 x 10 ⁻¹⁰)
Max. foreline pressure for N ₂	mbar (Torr)	14 (10.5)	14 (10.5)
Recommended forevacuum pump		TRIVAC D 65 B SCROLLVAC SC 30 D	TRIVAC D 65 B SCROLLVAC SC 30 D
Run-up time to 95% speed	min	≈ 5	≈ 5
Purge port	DN	16 KF	16 KF
Cooling water connection		2x G 1/8" (internal threads)	2x G 1/8" (internal threads)
Weight, approx.	kg (lbs)	19 (42)	19 (42)
Supply voltage, nominal	V DC	59	59
Max. power consumption	W	500	500

Ordering Information

TURBOVAC TW 701

TW 701 with integrated frequency converter				
Inlet flange	Foreline flange	Cooling method	Interface	
DN 160 ISO-K	DN 25 KF	Air-cooled	RS 232 C	Part No. 800051V0121
DN 160 ISO-K	DN 25 KF	Air-cooled	Profibus	Part No. 800051V0123
DN 160 ISO-K	DN 25 KF	Water-cooled	RS 232 C	Part No. 800051V0025
DN 160 ISO-K	DN 25 KF	Air-cooled	RS 485 C	Part No. 800051V0024
DN 160 ISO-K	DN 25 KF	Water-cooled	RS 485 C	Part No. 800051V0023
DN 160 ISO-K	DN 25 KF	Water-cooled	Profibus	Part No. 800051V0122
DN 160 CF	DN 25 KF	Air-cooled	RS 485 C	Part No. 800051V0027
DN 160 CF	DN 25 KF	Water-cooled	RS 485 C	Part No. 800051V0026
DN 200 CF (incl. splinter guard)	DN 25 KF	Water-cooled	RS 232 C	Part No. 800051V0022
Power supply unit TURBO.CONTROL 700				see chapter "Turbomolecular Pumps with Mechanical Rotor Suspension", para. "Electronic Frequency Converters"
Accessories, optional				
Splinter guard				
DN 160 ISO-K				Part No. 200 00 307
DN 160 CF				Part No. 200 17 247
Flange heater 160 CF				
230 V AC				Part No. 854 37
110 V AC				Part No. 854 38
Vibration absorber				
DN 160 ISO-K				Part No. 500 073
DN 160 CF				Part No. 500 072
OEM power supply, 59 V DC				Part No. 864 45
59 V DC cable				
3 m (10.5 ft)				Part No. 200 12 729
5 m (17.5 ft)				Part No. 200 12 730
10 m (35.0 ft)				Part No. 200 12 731
20 m (70.0 ft)				Part No. 200 15 064
Plug with integrated START/STOP switch				Part No. 152 48
Purge gas and venting valve, 24 V DC; $0.6 \text{ mbar} \times l \times s^{-1} = 36 \text{ sccm}$ (purge gas pressure, abs.; 1.5 to 6 bar)				Part No. 121 33
Accessories for serial interfaces RS 232 C and RS 485 C				see chapter "Turbomolecular Pumps", para. "Accessories"
Accessories, for the water connection				
Adaptor G (BPS) 1/8" – G (BPS) 1/4" pipe				Part No. 200 91 671 (2x required)
Gasket				Part No. 224 01 207 (2x required)
Adaptor G (BPS) 1/8" – 10 mm (0.39 in.) hose nozzle				Part No. 200 18 366 (2x required)
Gasket				Part No. 230 02 106 (2x required)
Adaptor G (BPS) 1/8" – NPT 1/8"				Part No. 200 12 742 (2x required)
Gasket				Part No. 238 20 110 (2x required)

TURBOVAC TW 1600



Typical Applications

- Data storage
- Flat panel displays
- Optical coating
- Large area coating
- R & D, e.g.
 - Fusions-Experimente
 - Space simulation
 - UHV applications

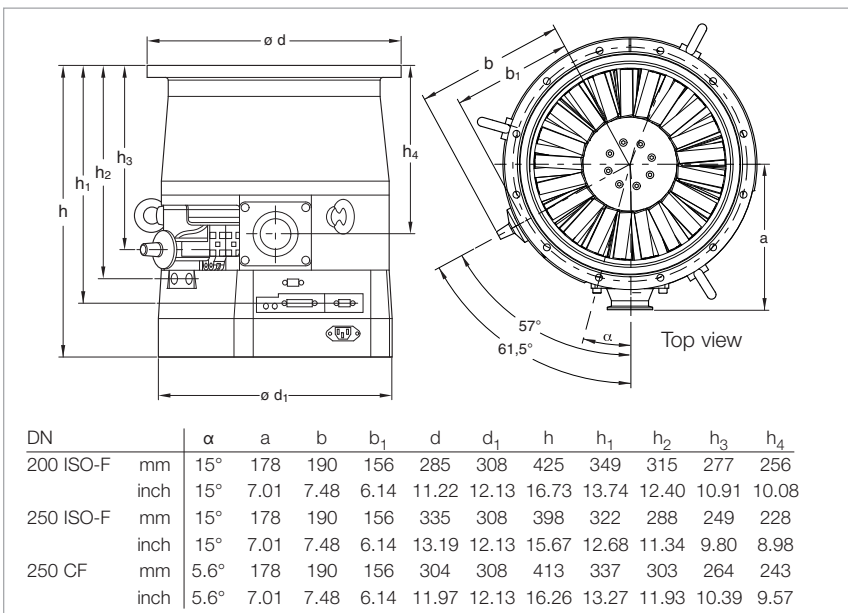

Dimensional drawing for the TURBOVAC TW 1600

Technical Features

- Frequency converter and power supply integrated
- Robust rotor design
- Operation in any orientation
- Highest pumping speed and throughput
- Oil-free pump for generating clean high and ultrahigh vacuum conditions
- Purge gas and venting valve integrated
- High foreline tolerance

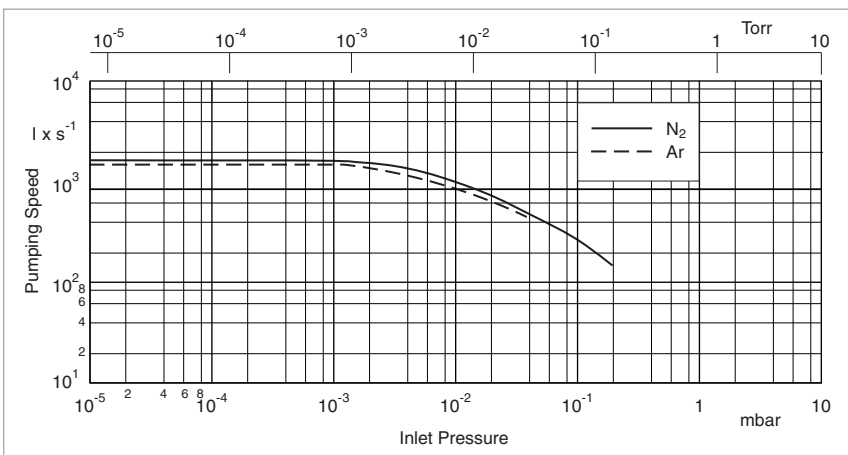

Pumping speed as a function of the inlet pressure

Advantages to the User

- Space-saving
- Easy to integrate into complex vacuum systems
- High productivity
- Low operating costs
- Operation with dry backing pumps

Technical Data

TURBOVAC TW 1600

Inlet flange	DN	200 ISO-F	250 ISO-F • 250 CF
Pumping speed			
N ₂	l x s ⁻¹	1000	1420
Ar	l x s ⁻¹	820	1200
Max. gas throughput			
N ₂	mbar x l x s ⁻¹	7.4	7.4
Ar	mbar x l x s ⁻¹	6.8	6.8
Compression ratio k ₀ for O-ring sealed pumps			
N ₂		1 x 10 ⁷	1 x 10 ⁷
Ar		3 x 10 ⁸	3 x 10 ⁸
Ultimate pressure	mbar (Torr)	< 3 x 10 ⁻¹⁰ (< 2.25 x 10 ⁻¹⁰)	< 3 x 10 ⁻¹⁰ (< 2.25 x 10 ⁻¹⁰)
Max. foreline pressure for N ₂	mbar (Torr)	8 (6)	8 (6)
Recommended forevacuum pump (alternatively)		TRIVAC D 65 B + RUVAC WA 501 DIVAC 4.8 VT SOGEVAC SV 25 SCROLLVAC SC 30 D	TRIVAC D 65 B + RUVAC WA 501 DIVAC 4.8 VT SOGEVAC SV 25 SCROLLVAC SC 30 D
Run-up time to 95% speed	min	< 10	< 10
Purge / vent port	DN	G 1/4"	G 1/4"
Cooling water connection		G 3/8"	G 3/8"
Weight, approx.	kg (lbs)	40 (88.3)	40 (88.3)
Supply voltage	V AC	100 - 240	100 - 240
Max. power consumption	W	700	700

Ordering Information

TURBOVAC TW 1600

Inlet flange	Foreline flange	Cooling method	Interface	Part No. 800041V2144 Part No. 800041V2444 Part No. 800041V2844
DN 200 ISO-F	DN 40 KF	Water-cooled	Profibus	
DN 250 ISO-F	DN 40 KF	Water-cooled	Profibus	
DN 250 CF	DN 40 KF	Water-cooled	Profibus	
Purge filter				Part No. 200 18 515
Accessories for serial interfaces RS 232 C and RS 485 C				see chapter "Turbomolecular Pumps", para. "Accessories"

Special Turbomolecular Pumps

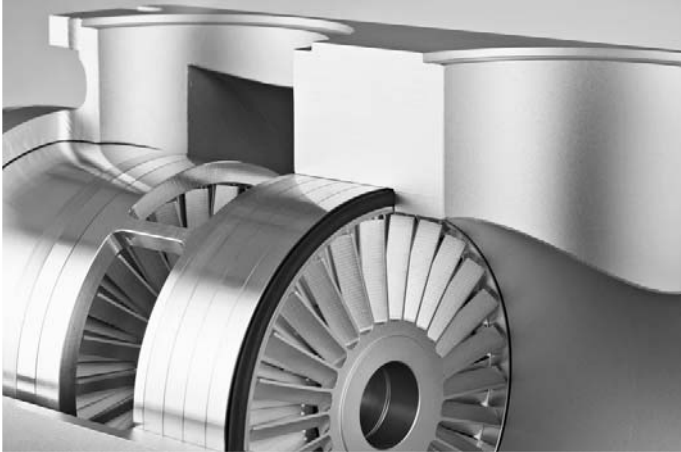

TURBOVAC Multi Inlet

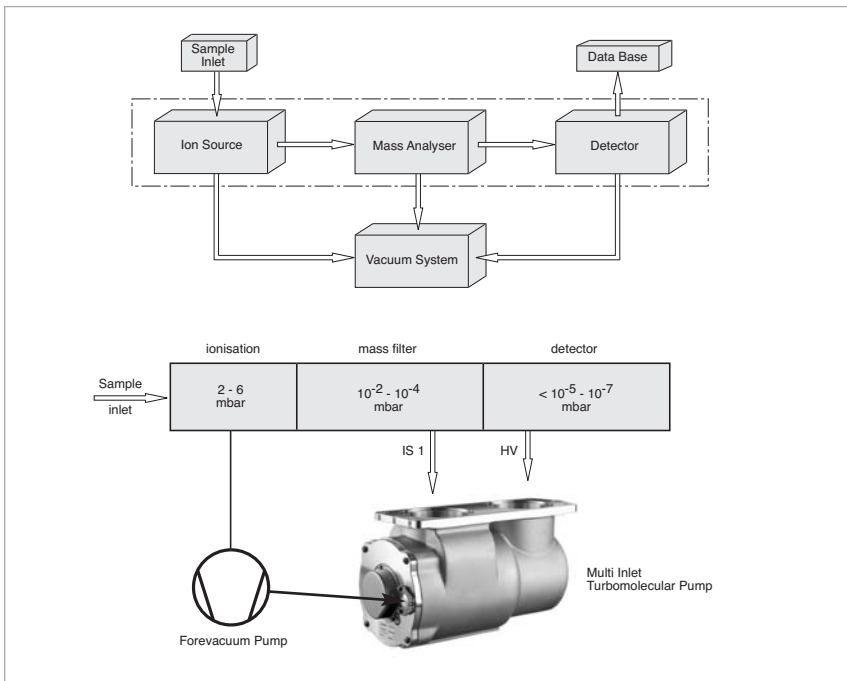

Application example: GC-MS

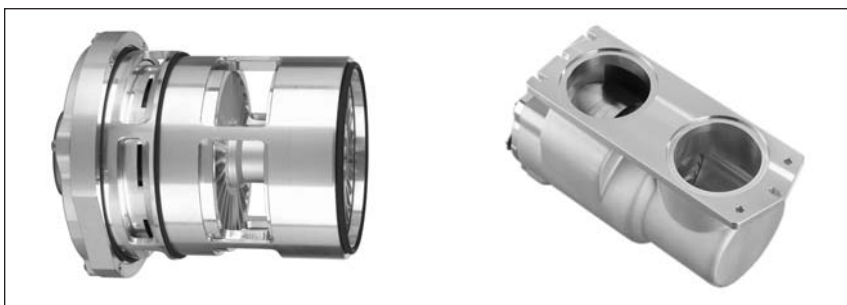

Multi inlet product examples
Left: cartridge, right: dual inlet

Advantages to the User

- Reduction of system costs
- Smaller size of the analysis system
- Reduction in the number of individual vacuum components
- Choice between cartridge or customised pump housing

Typical Applications

For example

- LC-MS (linking of a liquid chromatograph to a mass spectrometer)
- GC/MS (linking of a gas chromatograph to a mass spectrometer)
- TOF-MS (time-of-flight mass spectrometer)
- ICP-MS (inductively coupled plasma mass spectrometry)
- Helium leak detectors

Technical Characteristics

- Dual inlet (pumping down of two analysis chambers)
- Triple inlet (pumping down of three analysis chambers)
- High effective pumping speed

HV stage S = 60 to 400 l/s

Interstage IS1 S = 30 to 300 l/s

Interstage IS2 S = 5 to 30 l/s

- Cartridge solutions (without pump housing) are available
- Compact vacuum system

Customised versions are available upon request

Electronic Frequency Converters

TURBO.DRIVE TD20 *classic*



Technical Features

- For operating the TURBOVAC 151 (C), 361 (C), 600 C, 1000 C and 1100 (C) turbomolecular pump
- Front panel with LED
 - Status, Power, Error, pump run-up, pumping power
- Wide voltage range mains input
- Current interfaces like Profibus, DeviceNet, Ethernet/IP, RS 232 C, RS 485 C and 25-way terminal strip, available as options

Advantages to the User

- Easy integration within a vacuum system owing to the large variety of different modern interfaces as well as for modernising older systems
- Start/stop function through keys on the front panel
- Remote control and process control through analog and PLC compatible inputs and outputs
- Compatible to frequency converter NT 20, NT 151/361, NT 361 and NT 1000/1500

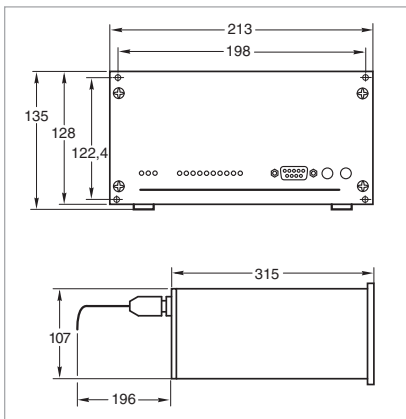

Dimensional drawing for the frequency converter Turbo.Drive TD20 *classic*

Technical Data

TURBO.DRIVE TD20 *classic*

Mains connection, 50 - 60 Hz; selectable	V	100 to 240 (-15% / +10%)
Max. output voltage	V	3 x 47
Overload current limit	A	5
Permissible ambient temperature	°C (°F)	0 to +45 (+32 to +113)
Protection class	IP	20
Dimensions (W x H x D)	mm (in.)	213 x 128 x 315 (1/2 19", 3 HU) 8.39 x 5.04 x 12.40 (1/2 19", 3 HU)
Weight, approx.	kg (lbs)	4 (8.8)

Ordering Information

TURBO.DRIVE TD20 *classic*

TURBO.DRIVE TD20 <i>classic</i> without interface with RS 232 C interface with RS 485 C interface with Profibus with 25 pol I/O with DeviceNet with Ethernet/IP		Part No. 800075V0001 Part No. 800075V0002 Part No. 800075V0004 Part No. 800075V0003 Part No. 800075V0005 Part No. 800075V0006 Part No. 800075V0007
Mains cable 3 m (10.5 ft) Euro plug UK plug US plug 6-15 P		Part No. 800102V0002 Part No. 800102V0003 Part No. 800102V1002
Connection cable TURBOVAC - converter 3 m (10.5 ft) 5 m (17.5 ft) 10 m (35.0 ft) 20 m (70.0 ft) 50 m (175.0 ft) 60 m (210.0 ft)0		Part No. 857 65 Part No. 857 66 Part No. 857 67 Part No. 857 68 Part No. 800152V008 Part No. 800152V007
19 in. rack mounting frame 3 HU		Part No. 161 00
Pump adapter cable (required when replacing a NT 151/361, NT 361 or NT 1000/1500)		Part No. 800 000 006
Adapter cable, 0.2 m long 25-way PLC interface to 2x Phoenix plugs (required when a NT 20 with connected PLC interface needs to be replaced)		Part No. 800152V0020
PC software TURBO.DRIVE Server ¹⁾		Part No. 800110V0102 (see Section „Accessories” at the end of the chapter)

¹⁾ Software supports only RS 232 C, RS 485 C and Profibus

TURBOTRONIK NT 10



Technical Features

- For operating the TURBOVAC 50 turbomolecular pump
- Bench top unit
- Also for rack mounting (1/4 19", 3 HU)
- Controls and indicators on the front panel
- Inputs for remote control and process controller
- Freely assignable relays (e.g. to control the backing pumps)

Technical Data

TURBOTRONIK NT 10

Mains connection, 50 - 60 Hz	V	90 - 140/180 - 260
Max. output voltage	V	3 x 150
Overload current limit	A	0.22
Permissible ambient temperature	°C (°F)	0 to +40 (+32 to +104)
Dimensions (W x H x D)	mm (in.)	106 x 128 x 233 (4.17 x 5.04 x 9.17)
Weight, approx.	kg (lbs)	1.5 (3.3)

Ordering Information

TURBOTRONIK NT 10

90 - 140 V (with US plug)	Part No. 859 01
180 - 260 V (with EURO plug)	Part No. 859 00
Connecting cable pump - converter	
3 m (10.5 ft)	Part No. 121 08
5 m (17.5 ft)	Part No. 121 09

TURBO.DRIVE S (TDS) for TW 70 H and TW 250 S



TURBO.DRIVE S (front side)

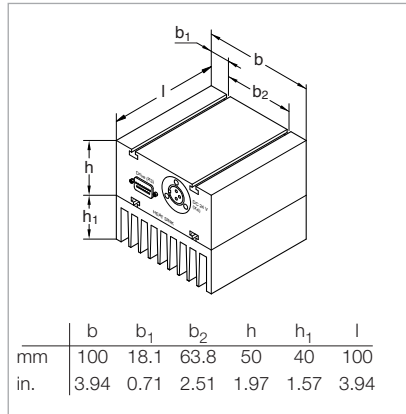

Dimensional drawing for the TURBO.DRIVE S
(rear side)

Technical Features

- Compact size
- RS 232 C, RS 485 C or Profibus interface
- Configurations
 - as a separate frequency converter
 - integrated within turbomolecular pump
- Remote control via remote control interface
- Flexible mounting
- Cost-effective supply of 24 V DC power

Technical Data

TURBO.DRIVE S

Input		
Voltage	V DC	24 ± 5%
Max. continuous current	A	7
Max. continuous power consumption	W	170
Ambient temperature	°C (°F)	+10 to +45 (+50 to +113)
Dimensions (W x H x D), including heat sink	mm (in.)	100 x 90 x 100 (3.94 x 3.54 x 3.94)
Weight	kg (lbs)	0.7 (1.55)
Serial interface		RS 232 C, RS 485 C or Profibus

Ordering Information

TURBO.DRIVE S

TURBO.DRIVE S with RS 232 C interface with RS 485 C interface with Profibus with RS 232 C interface and heat sink with RS 485 C interface and heat sink	Part No. 800070V0002 Part No. 800070V0003 Part No. 800070V0004 Part No. 800070V0005 Part No. 800070V0006
Connecting cable TDS - pump 1 m (3.5 ft) 3 m (10.5 ft) 5 m (17.5 ft)	Part No. 152 47 Part No. 864 40 Part No. 864 50
START/STOP switch (for manual operation)	Part No. 152 48
Hat rail adaptor as mounting aid	Part No. 800110V0003
Accessories for RS 232 C and RS 485 C interfaces	see chapter "Turbomolecular Pumps", para. "Accessories"

TURBO.DRIVE 300 (TD 300) for TW 70, TW 250 S and TW 290 H



TURBO.DRIVE 300 (front side)

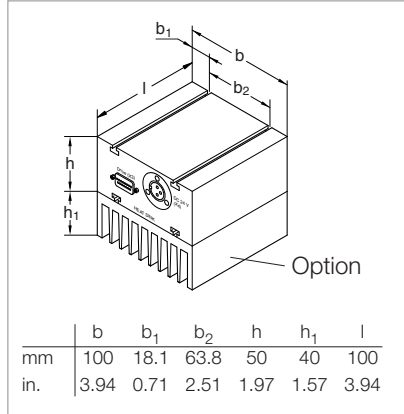

Dimensional drawing for the TURBO.DRIVE 300 (rear side)

Technical Features

- Compact size
- RS 232/422 C or RS 485 C interface
- Configurations
 - as a separate frequency converter
 - integrated within turbomolecular pump
- Remote control via remote control interface
- Flexible mounting
- Cost-effective supply of 24 V DC power

Technical Data

TURBO.DRIVE 300

Input		
Voltage	V DC	24 ± 5%
Max. continuous current	A	7
Max. continuous power consumption	W	170
Ambient temperature	°C (°F)	+5 to +45 (+41 to +113)
Dimensions (W x H x D)	mm (in.)	100 x 90 x 100 (3.94 x 3.54 x 3.94)
Weight	kg (lbs)	0.7 (1.55)
Serial interface		RS 232/422 C or RS 485 C

Ordering Information

TURBO.DRIVE 300

TURBO.DRIVE 300 with RS 232/422 C interface with RS 485 C interface with Profibus	Part No. 800072V0001 Part No. 800072V0003 Part No. 800072V0004
Connecting cable TD 300 - pump 1 m (3.5 ft) 3 m (10.5 ft) 5 m (17.5 ft)	Part No. 152 47 Part No. 864 40 Part No. 864 50
START/STOP switch (for manual operation)	Part No. 152 48
Hat rail adaptor as mounting aid	Part No. 800110V0003
Accessories for RS 232 C and RS 485 C interfaces	see chapter "Turbomolecular Pumps", para. "Accessories"

Power Supply PS 700 for TW 701 Turbomolecular Pumps

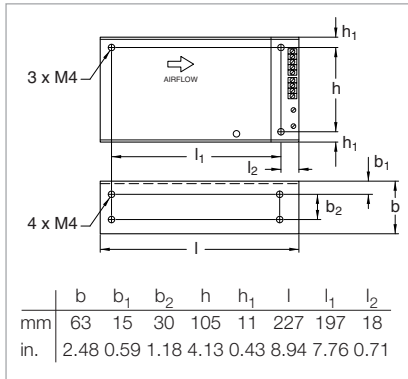

Dimensional drawing for the power supply PS 700

Technical Features

- 59 V DC OEM power supply for screw fixing in electrical cabinets

Technical Data

Power Supply PS 700

Input		
Mains voltage	V DC	85-265
Max. continuous power consumption	W	850
Output		
Voltage, nominal	V DC	59
Max. continuous current	A	13
Max. continuous power consumption	W	750
Ambient temperature	°C (°F)	0 to +70 (+32 to +158)
Dimensions (W x H x D)	mm (in.)	227 x 63 x 127 (8.94 x 2.48 x 5.0)
Weight	kg (lbs)	2 (4.4)

Ordering Information

Power Supply PS 700

OEM power supply 59 V DC	Part No. 864 45
59 V DC cable TW 700 – power supply	
3 m (10.5 ft)	Part No. 200 12 729
5 m (17.5 ft)	Part No. 200 12 730
10 m (35.0 ft)	Part No. 200 12 731
20 m (70.0 ft)	Part No. 200 15 064
Mains cable for OEM power supply, 2 m (7 ft)	
with EURO plug	Part No. 800102V0001
with US plug, 220 V AC	Part No. 800102V1001
with US plug, 115 V AC (7.5 ft)	Part No. 992 76 513
START/STOP switch for TURBO.DRIVE S (for manual operation)	Part No. 152 48

Note:

See the TPC and TSC controllers in the Product Section C10 "Turbomolecular Pump Systems" for additional controllers for the TURBOVAC TW 300 and TW 700

Power Supply Units for TURBO.DRIVE S, TURBO.DRIVE 300 and TW 700/701

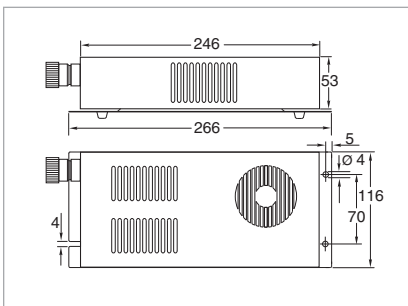

Dimensional drawing for the power supply
TURBO.POWER 300

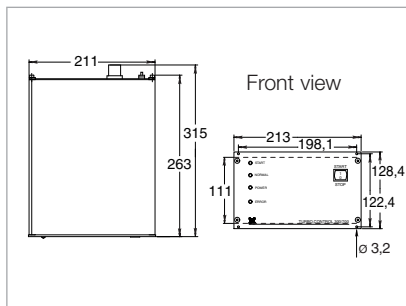

Dimensional drawing for the power supply
TURBO.CONTROL 300

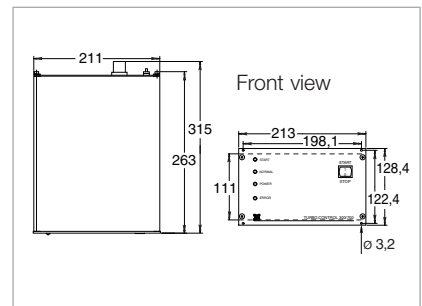

Dimensional drawing for the power supply
TURBO.CONTROL 700

Technical Features

- Cost-effective supply of 24 V DC power for TURBO.DRIVE S and TURBO.DRIVE 300
- Plug & play
- Bench top unit or for cabinet mounting

Technical Features

- For supplying 24 V DC power to the TURBO.DRIVE S and TURBO.DRIVE 300
- Plug & play
- Bench top unit or for cabinet mounting
- Mains switch
- START/STOP switch for the turbo-molecular pump
- Remote control via remote interface
- Status indicating LEDs and status relays

Technical Features

- For supplying 59 V DC power to the TW 700/701
- Plug & play
- Bench top unit or for cabinet mounting
- Mains switch
- START/STOP switch for the turbo-molecular pump
- Remote control via remote interface
- Status indicating LEDs and status relays

Technical Data

Power Supply

		TURBO.POWER 300	TURBO.CONTROL 300	TURBO.CONTROL 700
Input				
Mains voltage		85-264 V / 50/60 Hz	85-264 V / 50/60 Hz	85-264 V / 50/60 Hz
Max. power consumption	V A	300	300	805
Output				
Voltage, nominal	V DC	24	24	59
Max. continuous current	A	8.4	8.4	8.5
Ambient temperature	°C (°F)	0 to +40 (+32 to +104)	0 to +40 (+32 to +104)	0 to +40 (+32 to +104)
Dimensions (W x H x D)	mm (in.)	116 x 53 x 260 (4.57 x 2.09 x 10.24)	213 x 129 x 320 (8.39 x 5.08 x 12.6)	213 x 129 x 320 (8.39 x 5.08 x 12.6)
Weight	kg (lbs)	1.5 (3.3)	1.5 (3.3)	2.5 (5.52)

Ordering Information

Power Supply

	TURBO.POWER 300	TURBO.CONTROL 300	TURBO.CONTROL 700
Power supply			
TURBO.POWER 300	Part No. 800100V0002	-	-
TURBO.CONTROL 300	-	Part No. 800100V0001	-
TURBO.CONTROL 700	-	-	Part No. 800101V0001
DC cable			
frequency converter - power supply unit	24 V DC power cable	24 V DC control cable	59 V DC control cable
1 m (3.5 ft)	Part No. 800094V0100	Part No. 800091V0100	Part No. 800093V0100
3 m (10.5 ft)	Part No. 800094V0300	Part No. 800091V0300	Part No. 800093V0300
5 m (17.5 ft)	Part No. 800094V0500	Part No. 800091V0500	Part No. 800093V0500
10 m (35.0 ft)	Part No. 800094V1000	Part No. 800091V1000	Part No. 800093V1000
20 m (70.0 ft)	Part No. 800094V2000	Part No. 800091V2000	Part No. 800093V2000
Mains cable, 3 m (10.5 ft)			
with EURO plug	Part No. 800102V0002	Part No. 800102V0002	Part No. 800102V0002
UK plug	Part No. 800102V0003	Part No. 800102V0003	Part No. 800102V0003
with US plug 6-15 P, 220 V AC	Part No. 800102V1002	Part No. 800102V1002	Part No. 800102V1002
with US plug, 115 V AC (7.5 ft)	Part No. 992 76 513	Part No. 992 76 513	Part No. 992 76 513
Hat rail adaptor as mounting aid	Part No. 800110V0003	-	-

Magnetic Rotor Suspension with Integrated Frequency Converter, with Compound Stage

TURBOVAC MAG W 300/400 iP



Typical Applications

- Gas analysis systems
- Particle accelerators
- Electron microscopes
- Research

Technical Characteristics

- Installation in any orientation
- DN 100 or 160 ISO-K and/or CF high vacuum connection
- DN 16 KF with clamped forevacuum connection
- Purge gas/venting connection DN 16 KF with clamped connection (purge/vent)
- Water or air cooling optional
- CE and RoHS compliant; fulfilment of UL requirements
- 2 slots for industrial communications modules
 - Standard 9 pin 24 V PLC-IO in Control Slot
 - RS 232 C in Service Slot
 - further interfaces can be fitted: Ethernet, ProfiBus, DeviceNet, RS 485 C

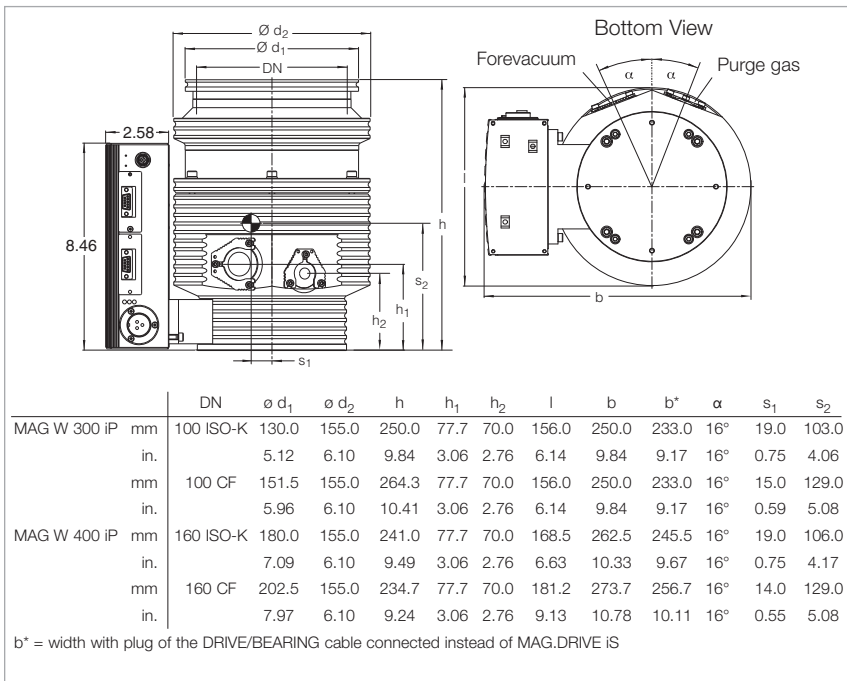

Dimensional drawing for the TURBOVAC MAG W 300/400 iP

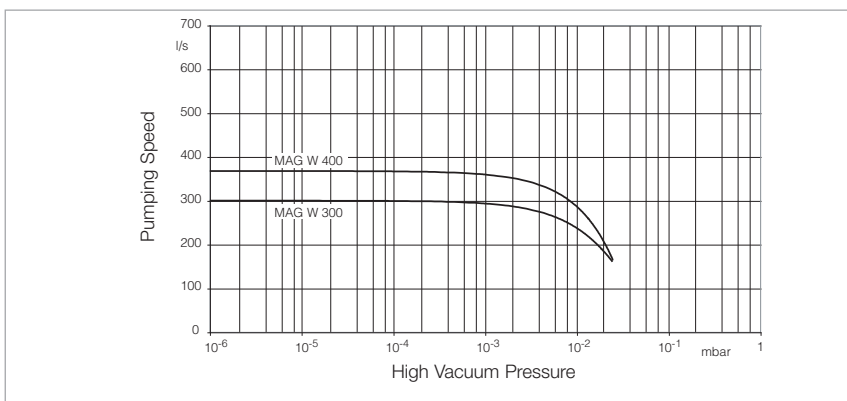

Pumping speed for N_2 of the TURBOVAC MAG W 300/400 iP as a function of the inlet pressure

Advantages to the User

- Highest pumping speed from the smallest possible size.
- New standard regarding maintenance free systems.
- Suitability for vibration sensitive applications in the area of analytical engineering, thin-film technology, electron microscopes, research, development among others.
- Flexibility due to the modular concept; the converter is optionally also available by way of a bench top unit.

Technical Data

TURBOVAC MAG W

300 iP

400 iP

High vacuum connection	DN	100 ISO-K	100 CF	160 ISO-K	160 CF
Pumping speed					
N ₂	l x s ⁻¹	300	300	365	365
H ₂	l x s ⁻¹	190	190	200	200
He	l x s ⁻¹	260	260	280	280
Rotational speed	min ⁻¹ (rpm)	58 800 (58 800)	58 800 (58 800)	58 800 (58 800)	58 800 (58 800)
Compression					
N ₂		1,0 x 10 ¹⁰	1,0 x 10 ¹⁰	1,0 x 10 ¹⁰	1,0 x 10 ¹⁰
H ₂		3.2 x 10 ³	3.2 x 10 ³	3.2 x 10 ³	3.2 x 10 ³
He		9.2 x 10 ⁴	9.2 x 10 ⁴	9.2 x 10 ⁴	9.2 x 10 ⁴
Ultimate pressure	mbar (Torr)	< 10 ⁻⁸ (< 0.75 x 10 ⁻⁸)	< 10 ⁻¹⁰ (< 0.75 x 10 ⁻¹⁰)	< 10 ⁻⁸ (< 0.75 x 10 ⁻⁸)	< 10 ⁻¹⁰ (< 0.75 x 10 ⁻¹⁰)
Max. degassing temperature	°C (°F)	–	80 (176)	–	80 (176)
Max. forevacuum pressure for N ₂	mbar (Torr)	8 (6)	8 (6)	8 (6)	8 (6)
Recommended backing pump		TRIVAC D 2,5 E TRIVAC D 8 B	TRIVAC D 2,5 E TRIVAC D 8 B	TRIVAC D 2,5 E TRIVAC D 8 B	TRIVAC D 2,5 E TRIVAC D 8 B
Run-up time	min	< 5	< 5	< 5	< 5
Forevacuum connection (clamped)	DN	16 KF	16 KF	16 KF	16 KF
Seal gas / venting connection (clamped)	DN	16 KF	16 KF	16 KF	16 KF
Water cooling connection (optional)	G	1/8"	1/8"	1/8"	1/8"
Weight, approx.	kg (lbs)	12 (26.49)	12 (26.49)	12 (26.49)	12 (26.49)
Accessories for all Pumps					
Integrated frequency converter					
TURBO.DRIVE iS					
Power supply	V	48	48	48	48
Residual ripple	%	< 2	< 2	< 2	< 2
Power rating					
maximum	W	400	400	400	400
at ultimate pressure	W	259	259	259	259
DC current consumption, max.	A	7.5 to 9.3	7.5 to 9.3	7.5 to 9.3	7.5 bis 9.3
DC power supply voltage range	V	43 to 53	43 to 53	43 to 53	43 bis 53
Length of the DC connection cable, max.					
for 3 x 1,5 mm ²	m	5	5	5	5
for 3 x 2,5 mm ²	m	20	20	20	20
Contact rating for the relays, max.		32 V; 0.5 A	32 V; 0.5 A	32 V; 0.5 A	32 V; 0.5 A
Permissible ambient temperature					
during operation	°C (°F)	10 to 40 (50 to 104)	10 to 40 (50 to 104)	10 to 40 (50 to 104)	10 to 40 (50 to 104)
during storage	°C (°F)	0 to 60 (0 to 140)	0 to 60 (0 to 140)	0 to 60 (0 to 140)	0 to 60 (0 to 140)
Relative humidity of the air, non-condensing					
	%	5 to 85	5 to 85	5 to 85	5 to 85
Protection class	IP	30	30	30	30
Overvoltage category		II	II	II	II
Pollution category		2	2	2	2

Ordering Information

TURBOVAC MAG W

300 iP

400 iP

Turbomolecular pump TURBOVAC MAG W with integrated frequency converter and seal gas connection		
DN 100 ISO-K	Part No. 410300V0505	-
DN 100 CF	Part No. 410300V0506	-
DN 160 ISO-K	-	Part No. 410400V0505
DN 160 CF	-	Part No. 410400V0506
Splitter guard		
DN 100 ISO-K		
coarse (3.2 x 3.2 mm)	Part No. 800132V0101	-
fine (1.6 x 1.6 mm)	Part No. 800132V0102	-
DN 100 CF		
coarse (3.2 x 3.2 mm)	Part No. 200 91 514	-
fine (1.6 x 1.6 mm)	Part No. E 200 17 195	-
DN 160 ISO-K	-	Part No. 200 00 307
DN 160 CF	-	Part No. 200 17 247
Seal gas and venting valve	upon request	upon request
Flange heater		
100 CF, 230 V, 50 Hz	Part No. 854 27	-
100 CF, 110 V, 60 Hz	Part No. 854 28	-
160 CF, 230 V, 50 Hz	-	Part No. 854 37
160 CF, 110 V, 60 Hz	-	Part No. 854 38
Water cooling	Part No. 410300V0101	Part No. 410300V0101
Air cooling	Part No. 410300V0102	Part No. 410300V0102

Ordering Information

TURBO.POWER 500

TURBO.POWER 500	Part No. 410300V0221
DC cable (connection between TURBO.POWER 500 and pump)	
1 m	Part No. 410300V2001
3 m	Part No. 410300V2003
5 m	Part No. 410300V2005
10 m	Part No. 410300V2010
20 m	Part No. 410300V2020
Mains cord	
3 m (EU)	Part No. 800102V0002
3 m (US)	Part No. 800102V1002

TURBOVAC MAG W 600/700 iP



Typical Applications

- Gas analysis systems
- Particle accelerators
- Electron microscopes
- Research

Technical Characteristics

- Installation in any orientation
- DN 160 or 200 ISO-K and/or CF high vacuum connection
- DN 25 KF with clamped forevacuum connection
- Purge gas/venting connection DN 16 KF with clamped connection (purge/vent)
- Water or air cooling optional
- CE and RoHS compliant; fulfilment of UL requirements
- 2 slots for industrial communications modules
 - Standard 9 pin 24 V PLC-IO in Control Slot
 - RS 232 C in Service Slot
 - further interfaces can be fitted: Ethernet, ProfiBus, DeviceNet, RS 485 C

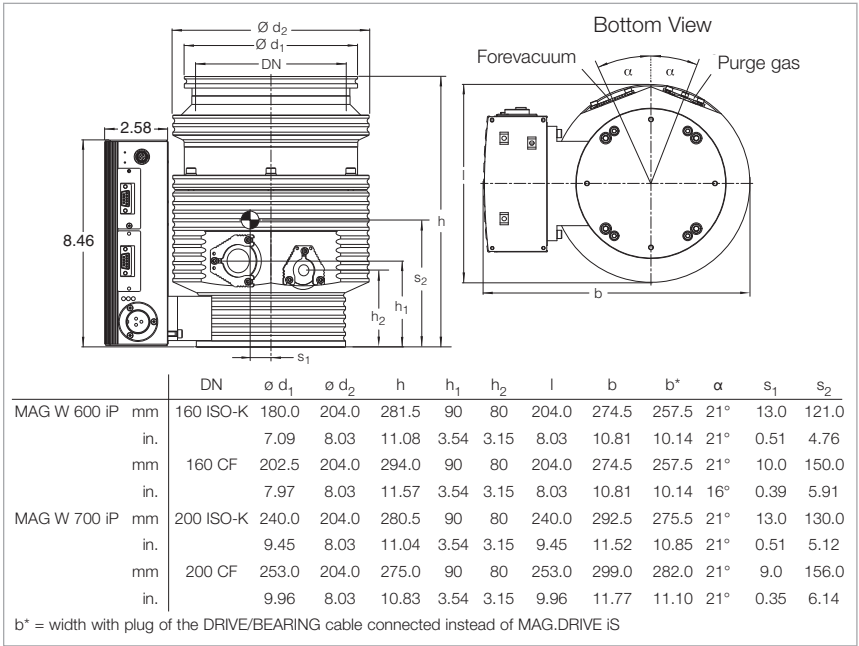

Dimensional drawing for the TURBOVAC MAG W 600/700 iP

Advantages to the User

- Highest pumping speed from the smallest possible size.
- New standard regarding maintenance free systems.
- Suitability for vibration sensitive applications in the area of analytical engineering, thin-film technology, electron microscopes, research, development among others.
- Flexibility due to the modular concept; the converter is optionally also available by way of a bench top unit.

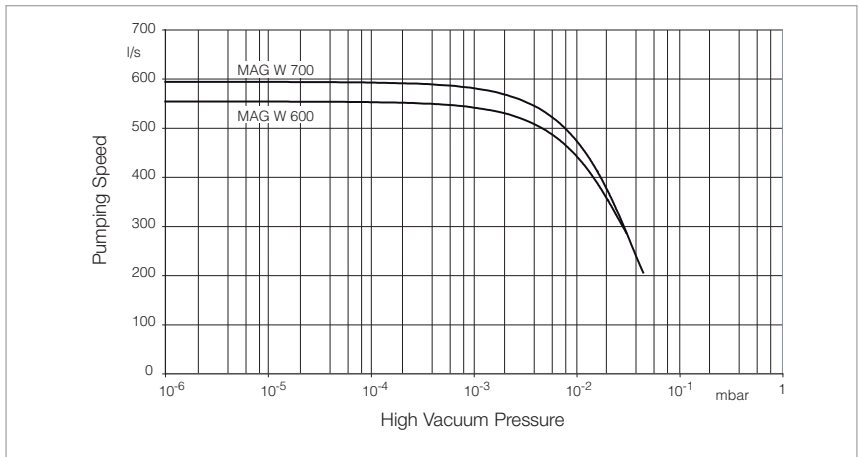

Pumping speed for N₂ of the TURBOVAC MAG W 300/400/600/700 iP as a function of the inlet pressure

Technical Data

TURBOVAC MAG W

600 iP

700 iP

High vacuum connection	DN	160 ISO-K	160 CF	200 ISO-K	200 CF
Pumping speed					
N ₂	l x s ⁻¹	550	550	590	590
H ₂	l x s ⁻¹	410	410	430	430
He	l x s ⁻¹	570	570	600	600
Rotational speed	min ⁻¹ (rpm)	48 000 (48 000)	48 000 (48 000)	48 000 (48 000)	48 000 (48 000)
Compression					
N ₂		1.6 x 10 ¹⁰	1.6 x 10 ¹⁰	1.6 x 10 ¹⁰	1.6 x 10 ¹⁰
H ₂		3.4 x 10 ⁴	3.4 x 10 ⁴	3.4 x 10 ⁴	3.4 x 10 ⁴
He		1.7 x 10 ⁶	1.7 x 10 ⁶	1.7 x 10 ⁶	1.7 x 10 ⁶
Ultimate pressure	mbar (Torr)	< 10 ⁻⁸ (< 0.75 x 10 ⁻⁸)	< 10 ⁻¹⁰ (< 0.75 x 10 ⁻¹⁰)	< 10 ⁻⁸ (< 0.75 x 10 ⁻⁸)	< 10 ⁻¹⁰ (< 0.75 x 10 ⁻¹⁰)
Max. degassing temperature	°C (°F)	–	80 (176)	–	80 (176)
Max. forevacuum pressure for N ₂	mbar (Torr)	6.0 (4.5)	6.0 (4.5)	6.0 (4.5)	6.0 (4.5)
Recommended backing pump		TRIVAC D 2,5 E TRIVAC D 8 B	TRIVAC D 2,5 E TRIVAC D 8 B	TRIVAC D 2,5 E TRIVAC D 8 B	TRIVAC D 2,5 E TRIVAC D 8 B
Run-up time	min	< 6	< 6	< 6	< 6
Forevacuum connection (clamped)	DN	25 KF	25 KF	25 KF	25 KF
Seal gas / venting connection (clamped)	DN	16 KF	16 KF	16 KF	16 KF
Water cooling connection (optional)	G	1/8"	1/8"	1/8"	1/8"
Weight, approx.	kg (lbs)	17 (37.53)	17 (37.53)	17 (37.53)	17 (37.53)
Accessories for all Pumps					
Integrated frequency converter					
TURBO.DRIVE iS					
Power supply	V	48	48	48	48
Residual ripple	%	< 2	< 2	< 2	< 2
Power rating					
maximum	W	400	400	400	400
at ultimate pressure	W	259	259	259	259
DC current consumption, max.	A	7.5 to 9.3	7.5 to 9.3	7.5 to 9.3	7.5 bis 9.3
DC power supply voltage range	V	43 to 53	43 to 53	43 to 53	43 bis 53
Length of the DC connection cable, max.					
for 3 x 1,5 mm ²	m	5	5	5	5
for 3 x 2,5 mm ²	m	20	20	20	20
Contact rating for the relays, max.		32 V; 0.5 A	32 V; 0.5 A	32 V; 0.5 A	32 V; 0.5 A
Permissible ambient temperature					
during operation	°C (°F)	10 to 40 (50 to 104)	10 to 40 (50 to 104)	10 to 40 (50 to 104)	10 to 40 (50 to 104)
during storage	°C (°F)	0 to 60 (0 to 140)	0 to 60 (0 to 140)	0 to 60 (0 to 140)	0 to 60 (0 to 140)
Relative humidity of the air, non-condensing					
	%	5 to 85	5 to 85	5 to 85	5 to 85
Protection class	IP	30	30	30	30
Overvoltage category		II	II	II	II
Pollution category		2	2	2	2

Ordering Information

TURBOVAC MAG W

600 iP

700 iP

Turbomolecular pump TURBOVAC MAG W with integrated frequency converter and seal gas connection	DN 160 ISO-K	Part No. 410600V0505	-
	DN 160 CF	Part No. 410600V0506	-
	DN 200 ISO-K	-	Part No. 410700V0505
	DN 200 CF	-	Part No. 410700V0506
Splitter guard	DN 160 ISO-K	Part No. 200 00 307	-
	DN 160 CF	Part No. 200 17 247	-
	DN 200 ISO-K	-	upon request
	DN 200 CF	-	upon request
Seal gas and venting valve	upon request	upon request	
Flange heater	160 CF, 230 V, 50 Hz	Part No. 854 37	-
	160 CF, 110 V, 60 Hz	Part No. 854 38	-
Water cooling	Part No. 410600V0101	Part No. 410600V0101	
Air cooling	Part No. 410600V0102	Part No. 410600V0102	

Ordering Information

TURBO.POWER 500

TURBO.POWER 500	Part No. 410300V0221	
DC cable (connection between TURBO.POWER 500 and pump)	1 m	Part No. 410300V2001
	3 m	Part No. 410300V2003
	5 m	Part No. 410300V2005
	10 m	Part No. 410300V2010
	20 m	Part No. 410300V2020
Mains cord	3 m (EU)	Part No. 800102V0002
	3 m (US)	Part No. 800102V1002

Magnetic Rotor Suspension with Separate Frequency Converter, without Compound Stage

TURBOVAC MAG 1500 CT



Typical Applications

- All major semiconductor processes such as Etch, CVD, PVD and Ion Implantation
- Load locks and transfer chambers

Technical Features

- Active 5-axis magnetic bearing system
- Patented KEPLA-COAT® for rotor and stator to prevent corrosion
- Low noise and vibration levels
- Operation in any orientation
- Advanced rotor design for high throughput
- Integrated purge gas system
- CT versions: Integrated temperature management system
- Bearing and temperature system are controlled digitally
- Intelligent power control system

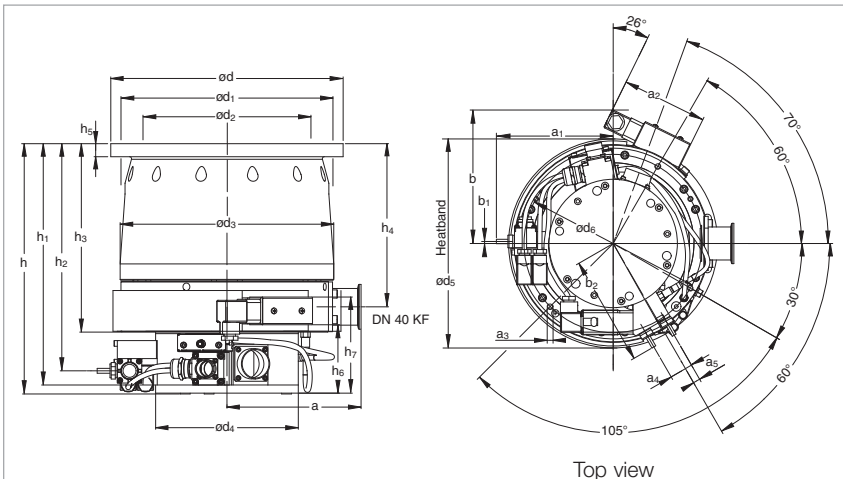

Top view

		a	a ₁	a ₂	a ₃	a ₄	a ₅	b	b ₁	b ₂	d	d ₁	d ₂
200 ISO-F	mm	164.5	159	116.5	M8 x 15	32	9	182	3	150	285	260	213
	in.	6.48	6.26	4.59	M8 x 0.6	1.26	0.35	7.17	0.12	5.91	11.22	10.24	8.39
250 ISO-F	mm	164.5	159	116.5	M8 x 15	32	9	182	3	150	335	310	213
	in.	6.48	6.26	4.59	M8 x 0.6	1.26	0.35	7.17	0.12	5.91	11.22	12.20	10.28

		d ₃	d ₄	d ₅	d ⁶	h	h ₁	h ₂	h ₃	h ₄	h ₅	h ₆	h ₇
200 ISO-F	mm	262	175	285	243	307	296	279	231	200	16	84	16
	in.	10.31	6.89	11.22	9.57	12.09	11.65	10.98	9.09	7.87	0.63	3.31	0.63
250 ISO-F	mm	262	175	285	243	307	296	279	231	200	16	84	16
	in.	10.31	6.89	11.22	9.57	12.09	11.65	10.98	9.09	7.87	0.63	3.31	0.63

Dimensional drawing for the TURBOVAC MAG 1500 CT

Advantages to the User

- Maintenance-free
- High throughput for all process gases
- High pumping speed at low pressure
- High foreline pressure tolerance: up to 1.7 mbar (1.13 Torr)
- High resistance against corrosive gases
- Robust against particles and deposits
- Temperature control up to 90 °C (194 °F) to avoid condensation
- Lowest weight and size in its class
- Application specific design

Technical Data

TURBOVAC MAG 1500 CT

Inlet flange	DN	200 ISO-F	250 ISO-F
Pumping speed according to PNEUROP			
N ₂	l x s ⁻¹	1100	1220
He	l x s ⁻¹	1000	1180
H ₂	l x s ⁻¹	980	1020
Speed	min ⁻¹	36 000	36 000
Compression ratio			
N ₂		> 10 ⁸	> 10 ⁸
Ultimate pressure according to DIN 28 400			
	mbar (Torr)	< 10 ⁻⁸ (< 0.75 x 10 ⁻⁸)	< 10 ⁻⁸ (< 0.75 x 10 ⁻⁸)
Max. foreline pressure for N ₂	mbar (Torr)	1.7 (1.2)	1.7 (1.2)
Recommended forevacuum pump			
Rotary vane pump or dry compressing pump offering a pumping speed of 100 m ³ /h		TRIVAC D 65 BCS	TRIVAC D 65 BCS
Run-up time	min	< 6	< 6
forevacuum flange	DN	40 KF	40 KF
Purge / vent port	VCR nut	1/4"	1/4"
Cooling water connection			
(OD of tube)	mm (in.)	6.4 (0.25)	6.4 (0.25)
Weight, approx.	kg (lbs)	32 (70)	32 (70)

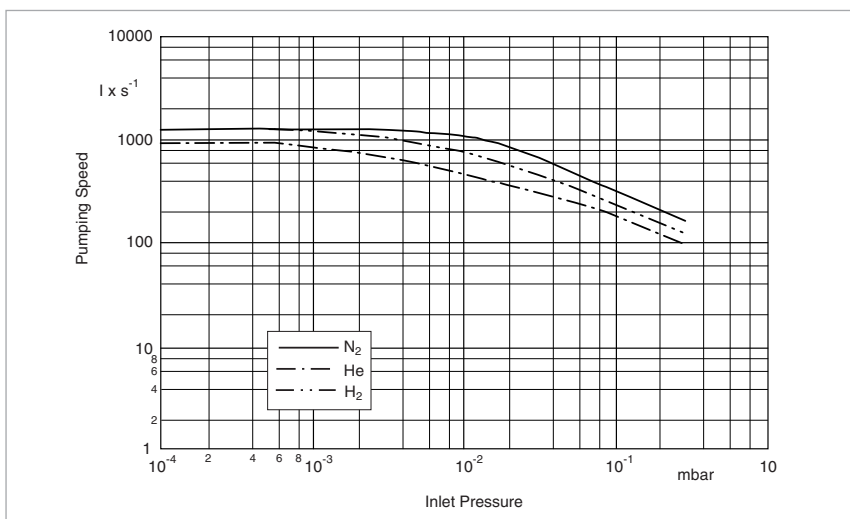

Pumping speed of the TURBOVAC MAG 1500 C/CT as a function of the inlet pressure

Ordering Information

TURBOVAC MAG 1500 CT

Inlet flange	DN	200 ISO-F	250 ISO-F
TURBOVAC MAG turbomolecular pump		Part No. 400020V0002	Part No. 400021V0002
Electronic frequency converter MAG.DRIVE digital with Profibus interface with RS 232 C interface with Ethernet interface		Part No. 400035V0011 Part No. 400035V0013 Part No. 400035V0014 Part No. 400035V0015	Part No. 400035V0011 Part No. 400035V0013 Part No. 400035V0014 Part No. 400035V0015
Plug-in control		Part No. 121 36	Part No. 121 36
Connecting cables converter – pump ¹⁾ 1.5 m (5.25 ft) DRIVE/BEARING 1.5 m (5.25 ft) TMS 3.0 m (10.5 ft) DRIVE/BEARING 3.0 m (10.5 ft) TMS 5.0 m (17.5 ft) DRIVE/BEARING 5.0 m (17.5 ft) TMS 10.0 m (35.0 ft) DRIVE/BEARING 10.0 m (35.0 ft) TMS 20.0 m (70.0 ft) DRIVE/BEARING 20.0 m (70.0 ft) TMS		Part No. 400036V0001 Part No. 400037V0001 Part No. 400036V0008 Part No. 400037V0008 Part No. 400036V0004 Part No. 400037V0004 Part No. 400036V0002 Part No. 400037V0002 Part No. 400036V0003 Part No. 400037V0003	Part No. 400036V0001 Part No. 400037V0001 Part No. 400036V0008 Part No. 400037V0008 Part No. 400036V0004 Part No. 400037V0004 Part No. 400036V0002 Part No. 400037V0002 Part No. 400036V0003 Part No. 400037V0003
Seal kit DN 250 metal		Part No. 200 07 901	Part No. 200 07 901

¹⁾ further connecting cables can be found under MAG.DRIVE digital in the section “Turbomolecular Pumps with Magnetic Rotor Suspension”, para. “Electronic Frequency Converters”

Magnetic Rotor Suspension with Separate Frequency Converter, with Compound Stage

TURBOVAC MAG W 300/400 P



Typical Applications

- Gas analysis systems
- Particle accelerators
- Electron microscopes
- Research

Technical Characteristics

- Installation in any orientation
- DN 100 or 160 ISO-K and/or CF high vacuum connection
- DN 16 KF with clamped forevacuum connection
- Purge gas/venting connection DN 16 KF with clamped connection (purge/vent)
- Water or air cooling optional
- CE and RoHS compliant; fulfilment of UL requirements

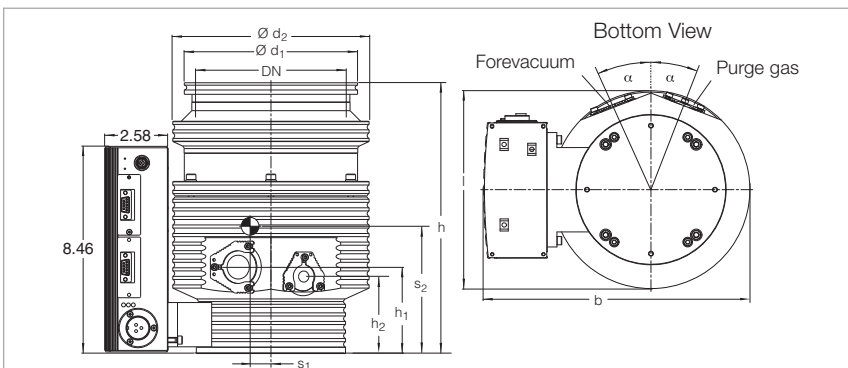

	DN	$\varnothing d_1$	$\varnothing d_2$	h	h ₁	h ₂	l	b	b'	α	s ₁	s ₂	
MAG W 300 P	mm	100 ISO-K	130.0	155.0	250.0	77.7	70.0	156.0	250.0	233.0	16°	19.0	103.0
	in.		5.12	6.10	9.84	3.06	2.76	6.14	9.84	9.17	16°	0.75	4.06
	mm	100 CF	151.5	155.0	264.3	77.7	70.0	156.0	250.0	233.0	16°	15.0	129.0
	in.		5.96	6.10	10.41	3.06	2.76	6.14	9.84	9.17	16°	0.59	5.08
MAG W 400 P	mm	160 ISO-K	180.0	155.0	241.0	77.7	70.0	168.5	262.5	245.5	16°	19.0	106.0
	in.		7.09	6.10	9.49	3.06	2.76	6.63	10.33	9.67	16°	0.75	4.17
	mm	160 CF	202.5	155.0	234.7	77.7	70.0	181.2	273.7	256.7	16°	14.0	129.0
	in.		7.97	6.10	9.24	3.06	2.76	9.13	10.78	10.11	16°	0.55	5.08

b' = width with plug of the DRIVE/BEARING cable connected instead of MAG.DRIVE iS

Dimensional drawing for the TURBOVAC MAG W 300/400 P

Advantages to the User

- Highest pumping speed from the smallest possible size.
- New standard regarding maintenance free systems.
- Suitability for vibration sensitive applications in the area of analytical engineering, thin-film technology, electron microscopes, research, development among others.
- Flexibility due to the modular concept; alternatively the pump is available also with an integrated frequency converter

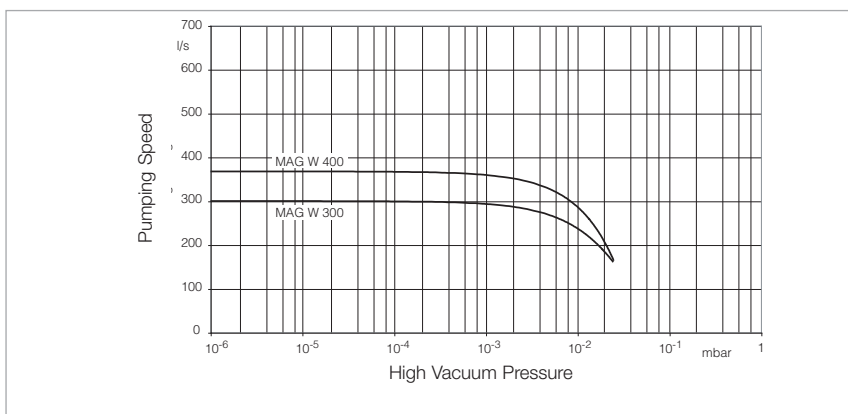

Pumping speed for N₂ of the TURBOVAC MAG W 300/400 P as a function of the inlet pressure

Technical Data

TURBOVAC MAG W

300 P

400 P

High vacuum connection	DN	100 ISO-K	100 CF	160 ISO-K	160 CF
Pumping speed					
N ₂	l x s ⁻¹	300	300	365	365
H ₂	l x s ⁻¹	190	190	200	200
He	l x s ⁻¹	260	260	280	280
Rotational speed	min ⁻¹ (rpm)	58 800 (58 800)	58 800 (58 800)	58 800 (58 800)	58 800 (58 800)
Compression					
N ₂		1,0 x 10 ¹⁰	1,0 x 10 ¹⁰	1,0 x 10 ¹⁰	1,0 x 10 ¹⁰
H ₂		3.2 x 10 ³	3.2 x 10 ³	3.2 x 10 ³	3.2 x 10 ³
He		9.2 x 10 ⁴	9.2 x 10 ⁴	9.2 x 10 ⁴	9.2 x 10 ⁴
Ultimate pressure	mbar (Torr)	< 10 ⁻⁸ (< 0.75 x 10 ⁻⁸)	< 10 ⁻¹⁰ (< 0.75 x 10 ⁻¹⁰)	< 10 ⁻⁸ (< 0.75 x 10 ⁻⁸)	< 10 ⁻¹⁰ (< 0.75 x 10 ⁻¹⁰)
Max. degassing temperature	°C (°F)	–	80 (176)	–	80 (176)
Max. forevacuum pressure for N ₂	mbar (Torr)	8 (6)	8 (6)	8 (6)	8 (6)
Recommended backing pump		TRIVAC D 2,5 E TRIVAC D 8 B	TRIVAC D 2,5 E TRIVAC D 8 B	TRIVAC D 2,5 E TRIVAC D 8 B	TRIVAC D 2,5 E TRIVAC D 8 B
Run-up time	min	< 5	< 5	< 5	< 5
Forevacuum connection (clamped)	DN	16 KF	16 KF	16 KF	16 KF
Seal gas / venting connection (clamped)	DN	16 KF	16 KF	16 KF	16 KF
Water cooling connection (optional)	G	1/8"	1/8"	1/8"	1/8"
Weight, approx.	kg (lbs)	12 (26.49)	12 (26.49)	12 (26.49)	12 (26.49)

Ordering Information

TURBOVAC MAG W

300 P

400 P

Turbomolecular pump TURBOVAC MAG W and seal gas connection		
DN 100 ISO-K	Part No. 410300V0005	-
DN 100 CF	Part No. 410300V0006	-
DN 160 ISO-K	-	Part No. 410400V0005
DN 160 CF	-	Part No. 410400V0006
Splitter guard		
DN 100 ISO-K		
coarse (3.2 x 3.2 mm)	Part No. 800132V0101	-
fine (1.6 x 1.6 mm)	Part No. 800132V0102	-
DN 100 CF		
coarse (3.2 x 3.2 mm)	Part No. 200 91 514	-
fine (1.6 x 1.6 mm)	Part No. E 200 17 195	-
DN 160 ISO-K	-	Part No. 200 00 307
DN 160 CF	-	Part No. 200 17 247
Seal gas and venting valve	upon request	upon request
Flange heater		
100 CF, 230 V, 50 Hz	Part No. 854 27	-
100 CF, 110 V, 60 Hz	Part No. 854 28	-
160 CF, 230 V, 50 Hz	-	Part No. 854 37
160 CF, 110 V, 60 Hz	-	Part No. 854 38
Water cooling	Part No. 410300V0101	Part No. 410300V0101
Air cooling	Part No. 410300V0102	Part No. 410300V0102

Ordering Information

MAG.DRIVE S

MAG.DRIVE S	Part No. 410300V0202
DRIVE/BEARING cable (connection between MAG.DRIVE S and pump)	
3 m	Part No. 410300V4003
5 m	Part No. 410300V4005
10 m	Part No. 410300V4010
20 m	Part No. 410300V4020
Mains cord	
3 m (EU)	Part No. 800102V0002
3 m (US)	Part No. 800102V1002

TURBOVAC MAG W 600/700 P



Typical Applications

- Gas analysis systems
- Particle accelerators
- Electron microscopes
- Research

Technical Characteristics

- Installation in any orientation
- DN 160 or 200 ISO-K and/or CF high vacuum connection
- DN 25 KF with clamped forevacuum connection
- Purge gas/venting connection DN 16 KF with clamped connection (purge/vent)
- Water or air cooling optional
- CE and RoHS compliant; fulfilment of UL requirements

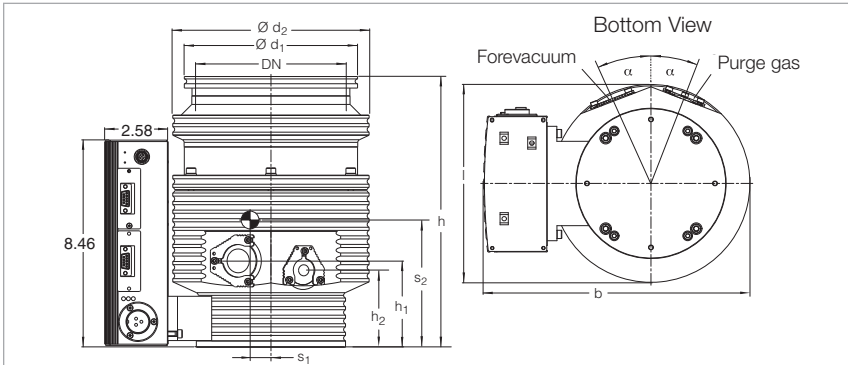

	DN	ø d ₁	ø d ₂	h	h ₁	h ₂	l	b	b*	α	s ₁	s ₂
MAG W 600 P	mm 160 ISO-K	180.0	204.0	281.5	90	80	204.0	274.5	257.5	21°	13.0	121.0
	in.	7.09	8.03	11.08	3.54	3.15	8.03	10.81	10.14	21°	0.51	4.76
MAG W 600 P	mm 160 CF	202.5	204.0	294.0	90	80	204.0	274.5	257.5	21°	10.0	150.0
	in.	7.97	8.03	11.57	3.54	3.15	8.03	10.81	10.14	16°	0.39	5.91
MAG W 700 P	mm 200 ISO-K	240.0	204.0	280.5	90	80	240.0	292.5	275.5	21°	13.0	130.0
	in.	9.45	8.03	11.04	3.54	3.15	9.45	11.52	10.85	21°	0.51	5.12
MAG W 700 P	mm 200 CF	253.0	204.0	275.0	90	80	253.0	299.0	282.0	21°	9.0	156.0
	in.	9.96	8.03	10.83	3.54	3.15	9.96	11.77	11.10	21°	0.35	6.14

b* = width with plug of the DRIVE/BEARING cable connected instead of MAG.DRIVE IS

Dimensional drawing for the TURBOVAC MAG W 600/700 P

Advantages to the User

- Highest pumping speed from the smallest possible size.
- New standard regarding maintenance free systems.
- Suitability for vibration sensitive applications in the area of analytical engineering, thin-film technology, electron microscopes, research, development among others.
- Flexibility due to the modular concept; alternatively the pump is available also with an integrated frequency converter

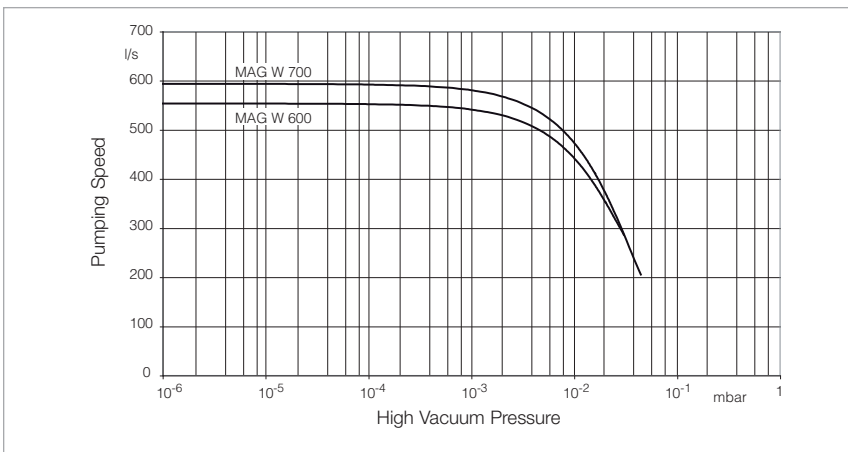

Saugvermögen für N₂ der MAG W 300/400/600/700 P in Abhängigkeit vom Einlass-Druck

Technical Data

TURBOVAC MAG W

600 P

700 P

High vacuum connection	DN	160 ISO-K	160 CF	200 ISO-K	200 CF
Pumping speed					
N ₂	l x s ⁻¹	550	550	590	590
H ₂	l x s ⁻¹	410	410	430	430
He	l x s ⁻¹	570	570	600	600
Rotational speed	min ⁻¹ (rpm)	48 000 (48 000)	48 000 (48 000)	48 000 (48 000)	48 000 (48 000)
Compression					
N ₂		1.6 x 10 ¹⁰	1.6 x 10 ¹⁰	1.6 x 10 ¹⁰	1.6 x 10 ¹⁰
H ₂		3.4 x 10 ⁴	3.4 x 10 ⁴	3.4 x 10 ⁴	3.4 x 10 ⁴
He		1.7 x 10 ⁶	1.7 x 10 ⁶	1.7 x 10 ⁶	1.7 x 10 ⁶
Ultimate pressure	mbar (Torr)	< 10 ⁻⁸ (< 0.75 x 10 ⁻⁸)	< 10 ⁻¹⁰ (< 0.75 x 10 ⁻¹⁰)	< 10 ⁻⁸ (< 0.75 x 10 ⁻⁸)	< 10 ⁻¹⁰ (< 0.75 x 10 ⁻¹⁰)
Max. degassing temperature	°C (°F)	–	80 (176)	–	80 (176)
Max. forevacuum pressure for N ₂	mbar (Torr)	6.0 (4.5)	6.0 (4.5)	6.0 (4.5)	6.0 (4.5)
Recommended backing pump		TRIVAC D 2,5 E TRIVAC D 8 B	TRIVAC D 2,5 E TRIVAC D 8 B	TRIVAC D 2,5 E TRIVAC D 8 B	TRIVAC D 2,5 E TRIVAC D 8 B
Run-up time	min	< 6	< 6	< 6	< 6
Forevacuum connection (clamped)	DN	25 KF	25 KF	25 KF	25 KF
Seal gas / venting connection (clamped)	DN	16 KF	16 KF	16 KF	16 KF
Water cooling connection (optional)	G	1/8"	1/8"	1/8"	1/8"
Weight, approx.	kg (lbs)	17 (37.53)	17 (37.53)	17 (37.53)	17 (37.53)

Ordering Information

TURBOVAC MAG W

600 P

700 P

Turbomolecular pump TURBOVAC MAG W and seal gas connection		
DN 160 ISO-K	Part No. 410600V0005	-
DN 160 CF	Part No. 410600V0006	-
DN 200 ISO-K	-	Part No. 410700V0005
DN 200 CF	-	Part No. 410700V0006
Splitter guard		
DN 160 ISO-K	Part No. 200 00 307	-
DN 160 CF	Part No. 200 17 247	-
DN 200 ISO-K	-	upon request
DN 200 CF	-	upon request
Seal gas and venting valve	upon request	upon request
Flange heater		
160 CF, 230 V, 50 Hz	Part No. 854 37	-
160 CF, 110 V, 60 Hz	Part No. 854 38	-
Water cooling	Part No. 410600V0101	Part No. 410600V0101
Air cooling	Part No. 410600V0102	Part No. 410600V0102

Ordering Information

MAG.DRIVE S

MAG.DRIVE S	Part No. 410300V0202
DRIVE/BEARING cable (connection between MAG.DRIVE S and pump)	
3 m	Part No. 410300V4003
5 m	Part No. 410300V4005
10 m	Part No. 410300V4010
20 m	Part No. 410300V4020
Mains cord	
3 m (EU)	Part No. 800102V0002
3 m (US)	Part No. 800102V1002

Magnetic Rotor Suspension with Separate Frequency Converter, with Compound Stage TURBOVAC MAG W 830/1300 C



Typical Applications

- Semiconductor processes, like PVD and ion implantation
- Transfer chambers
- Particle accelerators
- Research instruments and systems
- Coaters

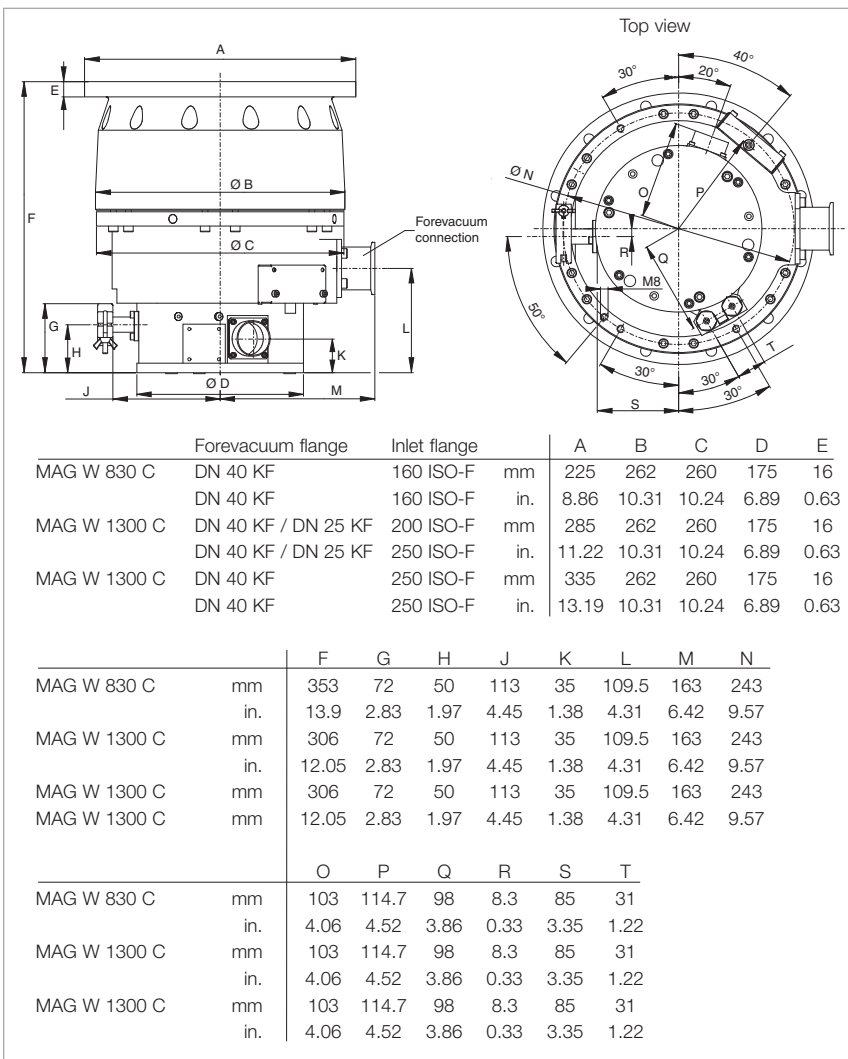

Dimensional drawing for the TURBOVAC MAG W 830/1300 C

Technical Features

- Active 5-axis magnetic bearing system
- Digital monitoring of the bearing system
- Low noise and vibration levels
- Operation in any orientation
- Advanced rotor design for high throughput
- purge gas connection
- Intelligent power control system

Advantages to the User

- Maintenance-free
- High throughput for all process gases
- High pumping speed at low pressure
- High foreline pressure tolerance: up to 2 mbar (1.5 Torr)
- Lowest weight and size in its class
- Application specific design

Technical Data

TURBOVAC MAG

		W 830	W 830 C	W 1300	W 1300 C	
Inlet flange	DN	160 CF	160 ISO-F	200 CF	200 ISO-F	250 ISO-F
Pumping speed according to PNEUROP						
N ₂	l x s ⁻¹	900	700	1170	1100	1220
He	l x s ⁻¹	900	650	1200	1050	1180
H ₂	l x s ⁻¹	740	300	920	920	1020
Speed	min ⁻¹	36000	24000	36000	36000	36000
Compression ratio						
N ₂		1.5 x 10 ⁸	> 5 x 10 ⁷	1.5 x 10 ⁸	> 10 ⁸	> 10 ⁸
Ultimate pressure according to DIN 28 400						
	mbar (Torr)	< 1 x 10 ⁻¹⁰ (< 0.75 x 10 ⁻¹⁰)	< 10 ⁻⁸ (< 0.75 x 10 ⁻⁸)	< 1 x 10 ⁻¹⁰ (< 0.75 x 10 ⁻¹⁰)	< 10 ⁻⁸ (< 0.75 x 10 ⁻⁸)	< 10 ⁻⁸ (< 0.75 x 10 ⁻⁸)
Max. foreline pressure for N ₂						
with convection cooling	mbar (Torr)	0.2 (0.15)	–	0.2 (0.15)	–	–
with water cooling	mbar (Torr)	2.0 (1.5)	2.0 (1.5)	2.0 (1.5)	2.0 (1.5)	2.0 (1.5)
Recommended forevacuum pump						
Rotary vane pump		TRIVAC D 65 BCS	TRIVAC D 65 BCS	TRIVAC D 65 BCS	TRIVAC D 65 BCS	TRIVAC D 65 BCS
or dry compressing pump offering a pumping speed of 100 m ³ /h						
Run-up time	min	< 6.0	< 4.0	< 6.0	< 6.0	< 6.0
forevacuum flange	DN	40 KF	40 KF	40 KF	40 KF	40 KF
Purge / vent port	DN	10 KF / 16 KF	10 KF / 16 KF	10 KF / 16 KF	10 KF / 16 KF	10 KF / 16 KF
Cooling water connection						
(OD tube)	mm (in.)	1/4"	1/4"	1/4"	6 (0.24)	6 (0.24)
Weight, approx.	kg (lbs)	35 (77.3)	32 (70.6)	35 (77.3)	32 (70.6)	32 (70.6)

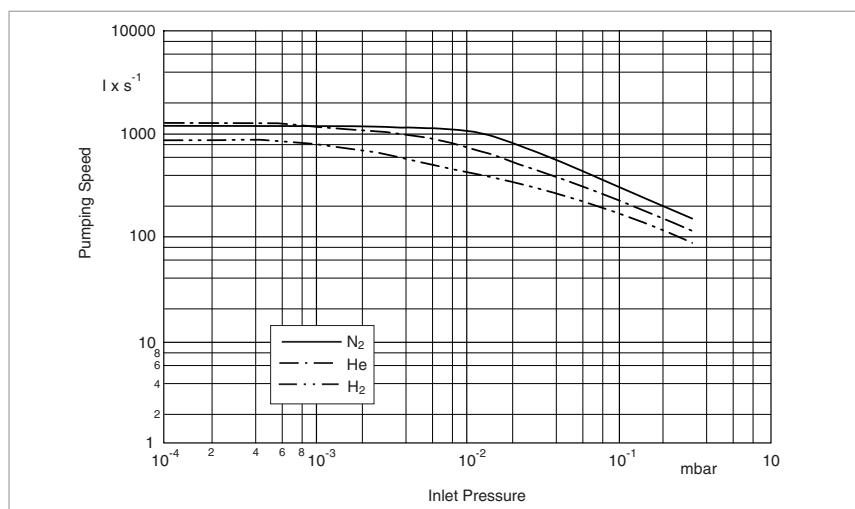

Pumping speed of the TURBOVAC MAG W 1300 C (DN 250) as a function of the inlet pressure

Ordering Information

TURBOVAC MAG

W 830

W 830 C

W 1300

W 1300 C

Inlet flange	DN	160 CF	160 ISO-F	200 CF	200 ISO-F	250 ISO-F
TURBOVAC MAG turbomolecular pump		Part No. 400100V0041	Part No. 400100V0005	Part No. 400110V0051	Part No. 400110V0011	Part No. 400110V0021
Electronic frequency converter MAG.DRIVE digital		Part No. 400035V0011	Part No. 400035V0011	Part No. 400035V0011	Part No. 400035V0011	Part No. 400035V0011
with Profibus interface		Part No. 400035V0013	Part No. 400035V0013	Part No. 400035V0013	Part No. 400035V0013	Part No. 400035V0013
with RS 232 C interface		Part No. 400035V0014	Part No. 400035V0014	Part No. 400035V0014	Part No. 400035V0014	Part No. 400035V0014
with Ethernet interface		Part No. 400035V0015	Part No. 400035V0015	Part No. 400035V0015	Part No. 400035V0015	Part No. 400035V0015
Plug-in control		Part No. 121 36	Part No. 121 36	Part No. 121 36	Part No. 121 36	Part No. 121 36
Pure gas valve		Part No. 121 33	Part No. 121 33	Part No. 121 33	Part No. 121 33	Part No. 121 33
Connecting cable converter – pump ¹⁾		Part No. 400036V0001	Part No. 400036V0001	Part No. 400036V0001	Part No. 400036V0001	Part No. 400036V0001
1.5 m (5.25 ft) DRIVE/BEARING		Part No. 400036V0008	Part No. 400036V0008	Part No. 400036V0008	Part No. 400036V0008	Part No. 400036V0008
3.0 m (10.5 ft) DRIVE/BEARING		Part No. 400036V0002	Part No. 400036V0002	Part No. 400036V0002	Part No. 400036V0002	Part No. 400036V0002
10.0 m (35.0 ft) DRIVE/BEARING		Part No. 400036V0003	Part No. 400036V0003	Part No. 400036V0003	Part No. 400036V0003	Part No. 400036V0003
20.0 m (70.0 ft) DRIVE/BEARING		Part No. 400038V0007	Part No. 400038V0007	Part No. 400038V0007	Part No. 400038V0007	Part No. 400038V0007
Connecting cable for optional purge gas valve		Part No. 400038V0006	Part No. 400038V0006	Part No. 400038V0006	Part No. 400038V0006	Part No. 400038V0006
1.5 m (5.25 ft) pump/converter		Part No. 400038V0002	Part No. 400038V0002	Part No. 400038V0002	Part No. 400038V0002	Part No. 400038V0002
3.0 m (10.5 ft) pump/converter		Part No. 400038V0009	Part No. 400038V0009	Part No. 400038V0009	Part No. 400038V0009	Part No. 400038V0009
10.0 m (35.0 ft) pump/converter						
20.0 m (70.0 ft) pump/converter						

¹⁾ further connecting cables can be found under MAG.DRIVE digital in the section "Turbomolecular Pumps with Magnetic Rotor Suspension", para. "Electronic Frequency Converters"

TURBOVAC MAG W 1500 CT



Typical Applications

- All major semiconductor processes such as Etch, CVD, PVD and Ion Implantation

Technical Features

- Active 5-axis magnetic bearing system
- Bearing and temperature system are controlled digitally
- Corrosion resistant
- Low noise and vibration levels
- Operation in any orientation
- Compound rotor design for high pumping speed and foreline pressure
- Integrated purge gas system
- CT versions: Integrated temperature management system
- Intelligent power control system

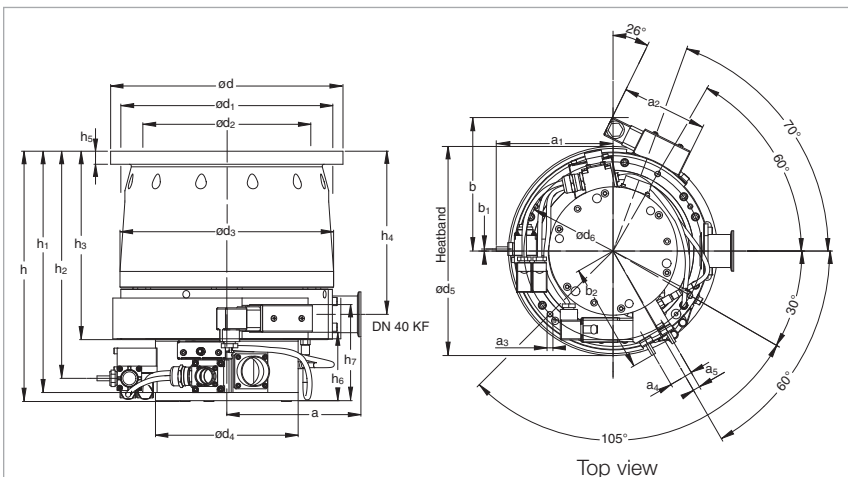

		a	a ₁	a ₂	a ₃	a ₄	a ₅	b	b ₁	b ₂	d	d ₁	d ₂
200 ISO-F	mm	164.5	159	116.5	M8 x 15	32	9	182	3	150	285	260	213
	in.	6.48	6.26	4.59	M8 x 0.6	1.26	0.35	7.17	0.12	5.91	11.22	10.24	8.39
250 ISO-F	mm	164.5	159	116.5	M8 x 15	32	9	182	3	150	335	310	261
	in.	6.48	6.26	4.59	M8 x 0.6	1.26	0.35	7.17	0.12	5.91	11.22	12.20	10.28
		d ₃	d ₄	d ₅	d ₆	h	h ₁	h ₂	h ₃	h ₄	h ₅	h ₆	h ₇
200 ISO-F	mm	262	175	285	243	307	296	279	231	200	16	84	118
	in.	10.31	6.89	11.22	9.57	12.09	11.65	10.98	9.09	7.87	0.63	3.31	4.65
250 ISO-F	mm	262	175	285	243	307	296	279	231	200	16	84	118
	in.	10.31	6.89	11.22	9.57	12.09	11.65	10.98	9.09	7.87	0.63	3.31	4.65

Dimensional drawing for the TURBOVAC MAG W 1500 CT

Advantages to the User

- Maintenance-free
- High throughput for all process gases
- High pumping speed at low pressure
- High foreline pressure tolerance: up to 2.6 mbar (1.95 Torr)
- High resistance against corrosive gases
- Robust against particles and deposits
- Temperature control up to 90 °C (194 °F) to avoid condensation
- Lowest weight and size in its class
- Application specific design

Technical Data

TURBOVAC MAG W 1500 CT

Inlet flange	DN	200 ISO-F	250 ISO-F	200 CF
Pumping speed according to PNEUROP				
N ₂	l x s ⁻¹	1100	1220	1100
He	l x s ⁻¹	1000	1180	1000
H ₂	l x s ⁻¹	800	850	800
Speed	min ⁻¹	36 000	36 000	36 000
Compression ratio				
N ₂		> 10 ⁸	> 10 ⁸	> 10 ⁸
Ultimate pressure according to DIN 28 400				
	mbar (Torr)	< 10 ⁻⁸ (< 0.7 x 10 ⁻⁸)	< 10 ⁻⁸ (< 0.7 x 10 ⁻⁸)	< 10 ⁻¹⁰ (< 0.7 x 10 ⁻⁸)
Max. foreline pressure for N ₂	mbar (Torr)	2.6 (1.95)	2.6 (1.95)	2.6 (1.95)
Recommended forevacuum pump				
Rotary vane pump or dry compressing pump offering a pumping speed of 100 m ³ /h		TRIVAC D 65 BCS	TRIVAC D 65 BCS	TRIVAC D 65 BCS
Run-up time to 95% speed	min	< 6	< 6	< 6
forevacuum flange	DN	40 KF	40 KF	40 KF
Purge / vent port	VCR nut	1/4"	1/4"	1/4"
Cooling water connection, hose nipple (OD tube)	mm (in.)	6.4 (0.25)	6.4 (0.25)	6.4 (0.25)
Weight, approx.	kg (lbs)	32 (70.6)	32 (70.6)	32 (70.6)

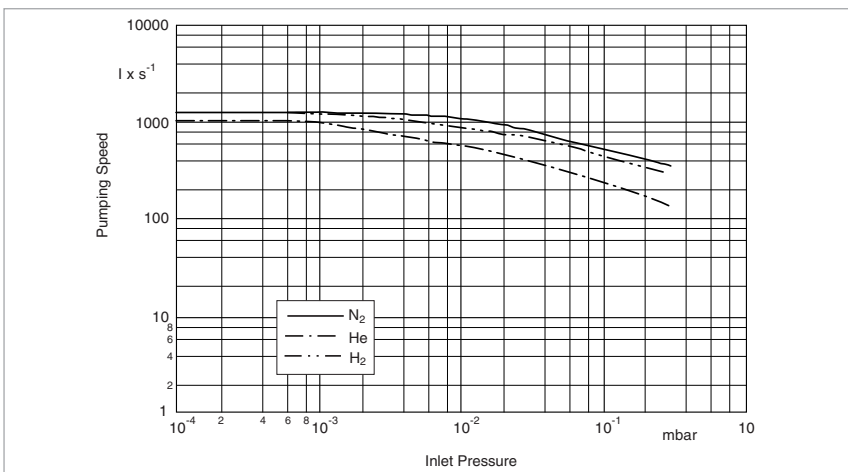

Pumping speed of the TURBOVAC MAG W 1500 CT (DN 250) as a function of the inlet pressure

Ordering Information

TURBOVAC MAG W 1500 CT

Inlet flange	DN	200 ISO-F	250 ISO-F	200 CF
TURBOVAC MAG turbomolecular pump		Part No. 400026V0002	Part No. 400027V0002	Part No. 400030V0002
Electronic frequency converter MAG.DRIVE digital with Profibus interface with RS 232 C interface with Ethernet interface		Part No. 400035V0011 Part No. 400035V0013 Part No. 400035V0014 Part No. 400035V0015	Part No. 400035V0011 Part No. 400035V0013 Part No. 400035V0014 Part No. 400035V0015	Part No. 400035V0011 Part No. 400035V0013 Part No. 400035V0014 Part No. 400035V0015
Plug-in control		Part No. 121 36	Part No. 121 36	Part No. 121 36
Connecting cable converter – pump ¹⁾				
1.5 m (5.25 ft) DRIVE/BEARING		Part No. 400036V0001	Part No. 400036V0001	Part No. 400036V0001
1.5 m (5.25 ft) TMS		Part No. 400037V0001	Part No. 400037V0001	Part No. 400037V0001
3.0 m (10.5 ft) DRIVE/BEARING		Part No. 400036V0008	Part No. 400036V0008	Part No. 400036V0008
3.0 m (10.5 ft) TMS		Part No. 400037V0008	Part No. 400037V0008	Part No. 400037V0008
5 m (17.5 ft) DRIVE/BEARING		Part No. 400036V0004	Part No. 400036V0004	Part No. 400036V0004
5 m (17.5 ft) TMS		Part No. 400037V0004	Part No. 400037V0004	Part No. 400037V0004
10 m (35.0 ft) DRIVE/BEARING		Part No. 400036V0002	Part No. 400036V0002	Part No. 400036V0002
10 m (35.0 ft) TMS		Part No. 400037V0002	Part No. 400037V0002	Part No. 400037V0002
20 m (70.0 ft) DRIVE/BEARING		Part No. 400036V0003	Part No. 400036V0003	Part No. 400036V0003
20 m (70.0 ft) TMS		Part No. 400037V0003	Part No. 400037V0003	Part No. 400037V0003
Seal kit DN 250 metal		Part No. 200 07 901	Part No. 200 07 901	Part No. 200 07 901

¹⁾ further connecting cables can be found under MAG.DRIVE digital in the section "Turbomolecular Pumps with Magnetic Rotor Suspension", para. "Frequency Converters"

TURBOVAC MAG W 2000 C/CT



Typical Applications

- All major semiconductor processes such as Etch, CVD, PVD and Ion Implantation

Technical Features

- Active 5-axis magnetic bearing system
- Patented KEPLA-COAT® for rotor and stator to prevent corrosion
- Low noise and vibration levels
- Installation in any orientation
- Compound rotor design for high pumping speed and foreline pressure
- Integrated purge gas system
- CT versions: Integrated temperature management system

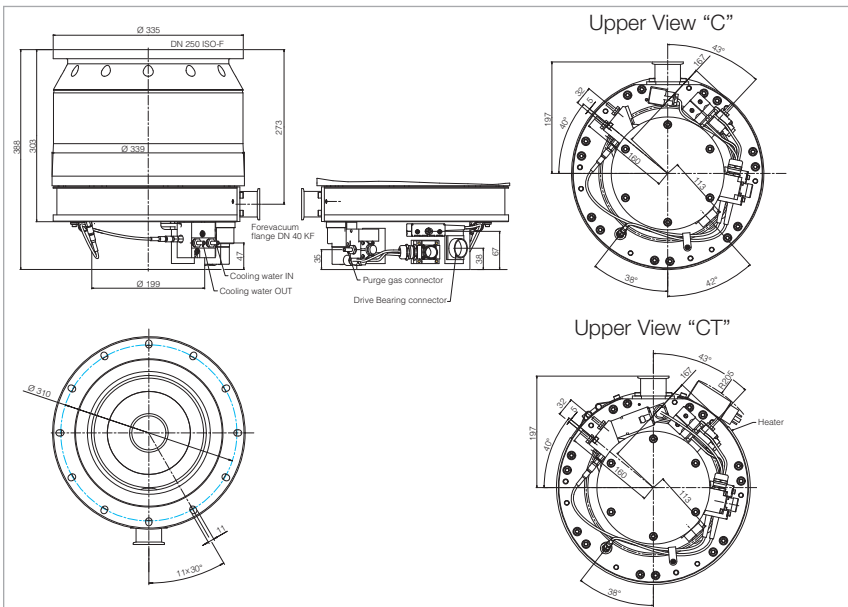

Dimensional drawing for the MAG W 2000 C/CT

Advantages to the User

- Maintenance-free
- High throughput for all etch gases
- High pumping speed at low pressure
- High foreline pressure tolerance: up to 5.3 mbar (4 Torr)
- High resistance against corrosive gases
- Robust against particles and deposits
- Temperature management system to avoid condensation
- Application specific design

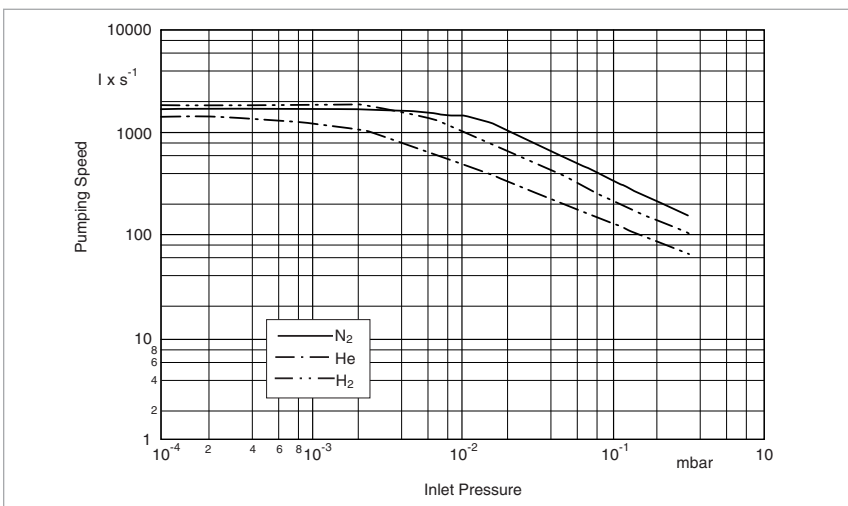

Pumping speed of the TURBOVAC MAG W 2000 CT (DN 250) as a function of the inlet pressure

Technical Data

TURBOVAC MAG

W 2000 C

W 2000 CT

Inlet flange	DN	250 ISO-F	250 ISO-F
Pumping speed according to PNEUROP			
N ₂	l x s ⁻¹	1650	1650
He	l x s ⁻¹	1800	1800
H ₂	l x s ⁻¹	1720	1720
Speed	min ⁻¹	28 800	28 800
Compression ratio			
N ₂		> 10 ⁸	> 10 ⁸
Ultimate pressure according to DIN 28 400	mbar (Torr)	< 10 ⁻⁸ (< 0.75 x 10 ⁻⁸)	< 10 ⁻⁸ (< 0.75 x 10 ⁻⁸)
Max. foreline pressure for N ₂	mbar (Torr)	3.5 (2.63)	3.5 (2.63)
Recommended forevacuum pump			
Rotary vane pump or dry compressing pump offering a pumping speed of 100 m ³ /h		TRIVAC D 65 BCS	TRIVAC D 65 BCS
Run-up time	min	< 8	< 8
forevacuum flange	DN	40 KF	40 KF
Purge / vent port	VCR nut	1/4"	1/4"
Cooling water connection (OD tube)	mm (in.)	6,4 (0.25)	6.4 (0.25)
Weight, approx.	kg (lbs)	68 (150)	68 (150)

TURBOVAC MAG

Ordering Information

W 2000 C

W 2000 CT

TURBOVAC MAG turbomolecular pump	Part No. 400047V0001	Part No. 400047V0002
Electronic frequency converter MAG.DRIVE digital with Profibus interface with RS 232 C interface with Ethernet interface	Part No. 400035V0011 Part No. 400035V0013 Part No. 400035V0014 Part No. 400035V0015	Part No. 400035V0011 Part No. 400035V0013 Part No. 400035V0014 Part No. 400035V0015
Plug-in control	Part No. 121 36	Part No. 121 36
Connecting cable converter – pump		
1.5 m (5.25 ft) DRIVE/BEARING	Part No. 400036V0001	Part No. 400036V0001
1.5 m (5.25 ft) TMS	Part No. 400037V0001	Part No. 400037V0001
3.0 m (10.5 ft) DRIVE/BEARING	Part No. 400036V0008	Part No. 400036V0008
3.0 m (10.5 ft) TMS	Part No. 400037V0008	Part No. 400037V0008
5.0 m (17.5 ft) DRIVE/BEARING	Part No. 400036V0004	Part No. 400036V0004
5.0 m (17.5 ft) TMS	Part No. 400037V0004	Part No. 400037V0004
10.0 m (35.0 ft) DRIVE/BEARING	Part No. 400036V0002	Part No. 400036V0002
10.0 m (35.0 ft) TMS	Part No. 400037V0002	Part No. 400037V0002
20.0 m (70.0 ft) DRIVE/BEARING	Part No. 400036V0003	Part No. 400036V0003
20.0 m (70.0 ft) TMS	Part No. 400037V0003	Part No. 400037V0003

TURBOVAC MAG W 2200 C



Typical Applications

- All major semiconductor processes such as Etch, CVD, PVD and Ion Implantation
- Coaters

Versions with CF highvacuum connection

- Particle accelerators
- Research instruments and systems

Technical Features

- Active 5-axis magnetic bearing system
- Bearing system are controlled digitally
- Low noise and vibration levels
- Operation in any orientation
- Compound rotor design for high pumping speed and foreline pressure
- purge gas connection
- Intelligent power control system

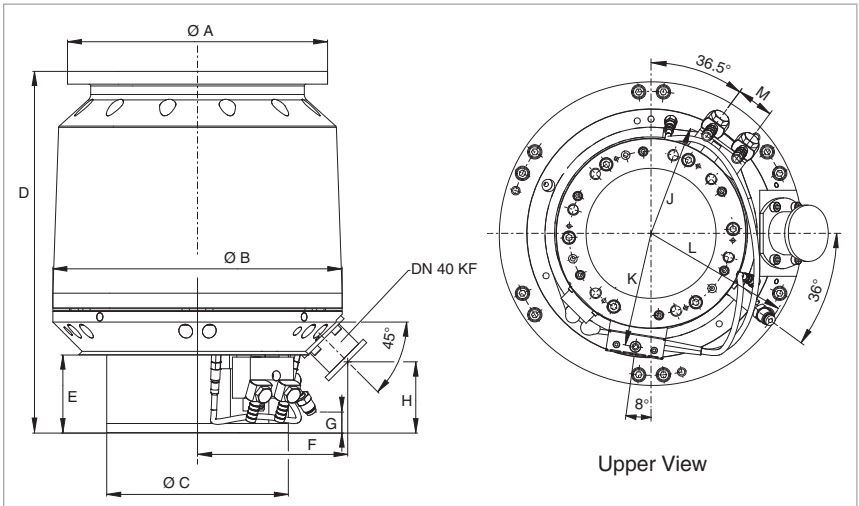

		A	B	C	D	E	F	G	H	J	K	L	M
200 ISO-F	mm	285	317	199	396	85.5	164.6	23	78	117	120	155	39
	in.	11.22	12.48	7.83	15.59	3.37	6.48	0.91	3.07	4.61	4.72	6.10	1.54
250 ISO-F	mm	335	317	199	371	85.5	164.6	23	78	117	120	155	39
	in.	13.19	12.48	7.83	14.61	3.37	6.48	0.91	3.07	4.61	4.72	6.10	1.54
250 CF	mm	305	317	199	401	85.5	164.6	23	78	117	120	155	39
	in.	12.01	12.48	7.83	15.79	3.37	6.48	0.91	3.07	4.61	4.72	6.10	1.54

Dimensional drawing for the TURBOVAC MAG W 2200 C

Advantages to the User

- Maintenance-free
- High throughput for all process gases
- High pumping speed at low pressure
- High foreline pressure tolerance: up to 2 mbar (1.5 Torr)
- Lowest weight and size in its class
- Application specific design

Technical Data

TURBOVAC MAG W 2200 C

W 2200

Inlet flange	DN	200 ISO-F	250 ISO-F	250 CF
Pumping speed according to PNEUROP				
N ₂	l x s ⁻¹	1600	2000	1800
Ar	l x s ⁻¹	1450	1900	1900
H ₂	l x s ⁻¹	1650	1800	1800
Speed	min ⁻¹	29400	29400	29400
Compression ratio				
N ₂		> 1 x 10 ⁸	> 1 x 10 ⁸	> 1 x 10 ⁸
Ultimate pressure according to DIN 28 400				
	mbar (Torr)	< 10 ⁻⁸ (< 0.75 x 10 ⁻⁸)	< 10 ⁻⁸ (< 0.75 x 10 ⁻⁸)	< 1 x 10 ⁻¹⁰ (< 0.75 x 10 ⁻¹⁰)
Max. foreline pressure for N₂				
with convection cooling	mbar (Torr)	–	–	0.1 (0.075)
with water cooling	mbar (Torr)	2 (1.5)	2 (1.5)	1 (0.75)
Recommended forevacuum pump				
Rotary vane pump or dry compressing pump offering a pumping speed of 100 m ³ /h		TRIVAC D 65 BCS	TRIVAC D 65 BCS	TRIVAC D 65 BCS
Run-up time to 95% speed	min	< 8	< 8	< 8
forevacuum flange	DN	40 KF	40 KF	40 KF
Purge / vent port	VCR nut	1/4"	1/4"	1/4"
Cooling water connection				
(OD tube)	mm (in.)	1/2"	1/2"	1/2"
Weight, approx.	kg (lbs)	48 (106)	48 (106)	60 (132.45)

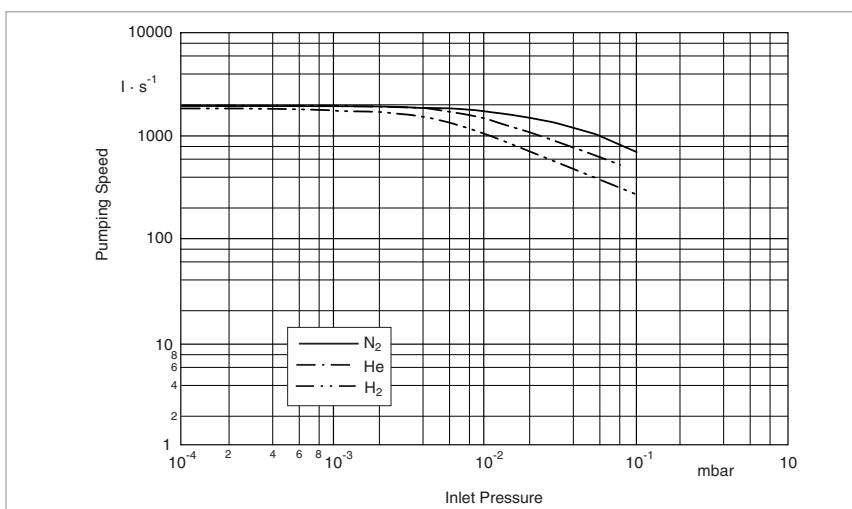

Pumping speed of the TURBOVAC MAG W 2200 C (DN 250) as a function of the inlet pressure

Ordering Information

TURBOVAC MAG

W 2200 C

W 2200

TURBOVAC MAG turbomolecular pump	Part No. 400081V0011	Part No. 400081V0021	Part No. 400081V0061
Electronic frequency converter MAG.DRIVE digital with Profibus interface with RS 232 C interface with Ethernet interface	Part No. 400035V0011 Part No. 400035V0013 Part No. 400035V0014 Part No. 400035V0015	Part No. 400035V0011 Part No. 400035V0013 Part No. 400035V0014 Part No. 400035V0015	Part No. 400035V0011 Part No. 400035V0013 Part No. 400035V0014 Part No. 400035V0015
Plug-in control	Part No. 121 36	Part No. 121 36	Part No. 121 36
Connecting cable converter – pump ¹⁾ 1.5 m (5.25 ft) DRIVE/BEARING 3.0 m (10.5 ft) DRIVE/BEARING 10.0 m (35.0 ft) DRIVE/BEARING 20.0 m (70.0 ft) DRIVE/BEARING	Part No. 400036V0001 Part No. 400036V0008 Part No. 400036V0002 Part No. 400036V0003	Part No. 400036V0001 Part No. 400036V0008 Part No. 400036V0002 Part No. 400036V0003	Part No. 400036V0001 Part No. 400036V0008 Part No. 400036V0002 Part No. 400036V0003
Connection cable for optional seal gas valve 1.5 m pump/converter 3.0 m pump/converter 10.0 m pump/converter 20.0 m pump/converter	Part No. 400038V0007 Part No. 400038V0006 Part No. 400038V0002 Part No. 400038V0009	Part No. 400038V0007 Part No. 400038V0006 Part No. 400038V0002 Part No. 400038V0009	Part No. 400038V0007 Part No. 400038V0006 Part No. 400038V0002 Part No. 400038V0009

¹⁾ further connecting cables can be found under MAG.DRIVE digital in the section "Turbomolecular Pumps with Magnetic Rotor Suspension", para. "Electronic Frequency Converters"

TURBOVAC MAG W 2800/3200 C/CT



TURBOVAC MAG W 2800 CT (left) and TURBOVAC MAG W 3200 CT (right)

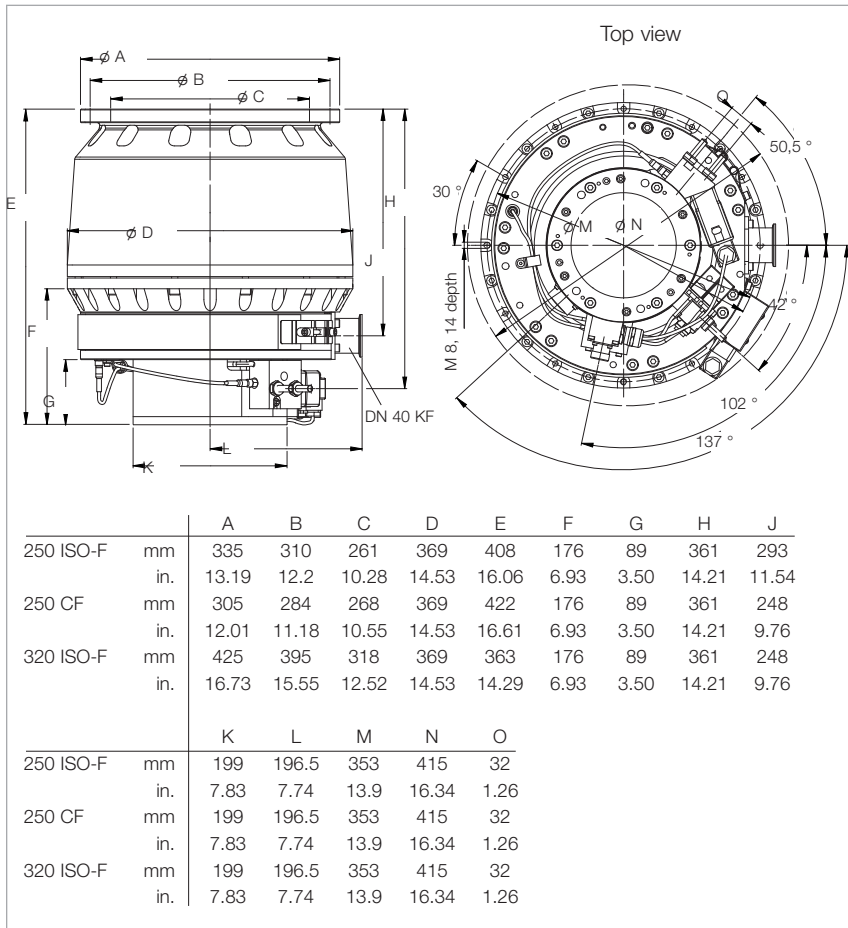

Dimensional drawing for the TURBOVAC MAG W 2800/3200 C/CT

Typical Applications

- All major semiconductor processes such as Etch, CVD, PVD and Ion Implantation

Versions with CF highvacuum connection

- Particle accelerators
- Research instruments and systems

Technical Features

- Active 5-axis magnetic bearing system
- Bearing and temperature system are controlled digitally
- Corrosion resistant
- Low noise and vibration levels
- Installation in any orientation
- Compound rotor design for high pumping speed and foreline pressure
- Integrated purge gas system
- CT versions: Integrated temperature management system
- Intelligent power control system

Advantages to the User

- Maintenance-free
- High throughput for all process gases
- High pumping speed at low pressure
- High foreline pressure tolerance: up to 2 mbar (1.5 Torr)
- High resistance against corrosive gases
- Robust against particles and deposits
- Temperature control up to 90 °C (194 °F) to avoid condensation
- Lowest weight and size in its class
- Application specific design

Technical Data

TURBOVAC MAG

		W 2800 C	W 2800 CT	W 2800	W 3200 CT
Inlet flange	DN	250 ISO-F	250 ISO-F	250 CF	320 ISO-F
Pumping speed according to PNEUROP					
N ₂	l x s ⁻¹	2650	2650	2400	3200
Ar	l x s ⁻¹	2450	2450	2450	3000
H ₂	l x s ⁻¹	2100	2100	2100	2250
Speed	min ⁻¹	28800	28800	28800	28800
Compression ratio					
N ₂		1 x 10 ⁸	1 x 10 ⁸	1 x 10 ⁹	1 x 10 ⁸
Ultimate pressure according to DIN 28 400					
	mbar (Torr)	< 10 ⁻⁸ (< 0.75 x 10 ⁻⁸)	< 10 ⁻⁸ (< 0.75 x 10 ⁻⁸)	< 1 x 10 ⁻¹⁰ (< 0.75 x 10 ⁻¹⁰)	< 10 ⁻⁸ (< 0.75 x 10 ⁻⁸)
Max. foreline pressure for N₂					
with convection cooling	mbar (Torr)	–	–	0.3 (0.23)	–
with water cooling	mbar (Torr)	2 (1.5)	2 (1.5)	3 (2.25)	2 (1.5)
Recommended forevacuum pump					
Rotary vane pump or dry compressing pump offering a pumping speed of 100 m ³ /h		TRIVAC D 65 BCS	TRIVAC D 65 BCS	TRIVAC D 65 BCS	TRIVAC D 65 BCS
Run-up time	min	< 10	< 10	< 10	< 10
Forevacuum flange	DN	40 KF	40 KF	40 KF	40 KF
Purge / vent port	VCR nut	1/4"	1/4"	1/4"	1/4"
Cooling water connection	Swagelok tube	1/4"	1/4"	1/4"	1/4"
Weight, approx.	kg (lbs)	64 (141.3)	64 (141.3)	75 (165.6)	65 (143.5)

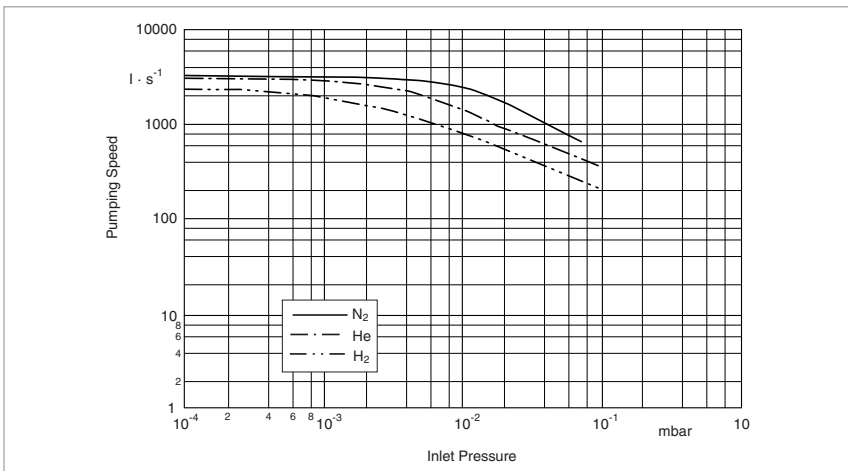

Pumping speed of the TURBOVAC MAG W 3200 C (DN 320) as a function of the inlet pressure

Ordering Information

TURBOVAC MAG

		W 2800 C	W 2800 CT	W 2800	W 3200 CT
Inlet flange	DN	250 ISO-F	250 ISO-F	250 CF	320 ISO-F
TURBOVAC MAG turbomolecular pump		Part No. 400000V0001	Part No. 400000V0002	Part No. 400006V0071	Part No. 400003V0002
Electronic frequency converter MAG.DRIVE digital		Part No. 400035V0011	Part No. 400035V0011	Part No. 400035V0011	Part No. 400035V0011
with Profibus interface		Part No. 400035V0013	Part No. 400035V0013	Part No. 400035V0013	Part No. 400035V0013
with RS 232 C interface		Part No. 400035V0014	Part No. 400035V0014	Part No. 400035V0014	Part No. 400035V0014
with Ethernet interface		Part No. 400035V0015	Part No. 400035V0015	Part No. 400035V0015	Part No. 400035V0015
Plug-in control		Part No. 121 36	Part No. 121 36	Part No. 121 36	Part No. 121 36
Connecting cable converter – pump ¹⁾					
1.5 m (5.25 ft) DRIVE/BEARING		Part No. 400036V0001	Part No. 400036V0001	Part No. 400036V0001	Part No. 400036V0001
1.5 m (5.25 ft) TMS		Part No. 400037V0001	Part No. 400037V0001	-	Part No. 400037V0001
3.0 m (10.5 ft) DRIVE/BEARING		Part No. 400036V0008	Part No. 400036V0008	Part No. 400036V0008	Part No. 400036V0008
3.0 m (10.5 ft) TMS		Part No. 400037V0008	Part No. 400037V0008	-	Part No. 400037V0008
5.0 m (17.5 ft) DRIVE/BEARING		Part No. 400036V0004	Part No. 400036V0004	Part No. 400036V0004	Part No. 400036V0004
5.0 m (17.5 ft) TMS		Part No. 400037V0004	Part No. 400037V0004	-	Part No. 400037V0004
10.0 m (35.0 ft) DRIVE/BEARING		Part No. 400036V0002	Part No. 400036V0002	Part No. 400036V0002	Part No. 400036V0002
10.0 m (35.0 ft) TMS		Part No. 400037V0002	Part No. 400037V0002	-	Part No. 400037V0002
20.0 m (70.0 ft) DRIVE/BEARING		Part No. 400036V0003	Part No. 400036V0003	Part No. 400036V0003	Part No. 400036V0003
20.0 m (70.0 ft) TM		Part No. 400037V0003	Part No. 400037V0003	-	Part No. 400037V0003
Seal kit DN 250 metal		Part No. 200 07 901	Part No. 200 07 901	Part No. 200 07 901	Part No. 200 07 901

¹⁾ further connecting cables can be found under MAG.DRIVE digital in the section "Turbomolecular Pumps with Magnetic Rotor Suspension", para. "Electronic Frequency Converters"

Electronic Frequency Converters

MAG.DRIVE S



MAG.DRIVE S without control

Advantages to the User

- Operation of turbomolecular pumps with magnetically levitated rotors:
MAG W 300/400 and
MAG W 600/700
- Easy operation through the controls
- Communication to host computer of the customer via serial interface and conventional interface possible
- Setting of speed and other functions
- Warning in case the pump is running out of specification
- Storing of all parameters in the pump's memory
- Small size and low weight
- Integrated fan

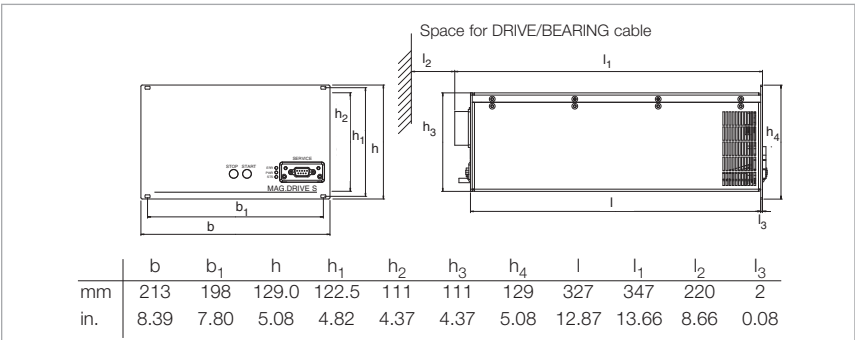

Dimensional drawing for the MAG.DRIVE S

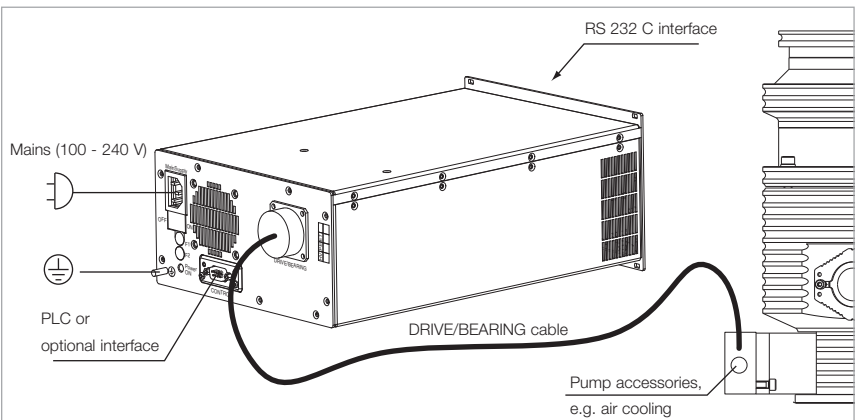

Overview connection lines

Technical Data

MAG.DRIVE S

Voltage range	V	100 - 240, +/-10%
Line supply frequency	Hz	50 / 60
Load		
Stand-by	W	100
Maximum	W	400
Max. voltage motor	V	48
Max. pump current	A	6
Fuses F1, F2 5 x 20 mm		0 A fast blow high breaking capacity 250 V
System fuse		L or G characteristic
Max. frequency	Hz	0 to 2000
Load capability, relay output X1	V / A	32 / 0,5
Temperature		
during operation	°C (°F)	0 to 45 (+32 to +113)
during storage	°C (°F)	-10 to +60 (+14 to +140)
Relative air humidity	%	95 (non condensing)
Protection class	IP	30
Overvoltage category		II
Contamination level in accordance with EN 61010		2
Weight, approx.	kg (lbs)	10 (22)

Ordering Information

MAG.DRIVE S

Electronic Frequency Converter MAG.DRIVE S	Part No. 410300V0202
Connection cable DRIVE/BEARING (Connection between pump and MAG.DRIVE S)	
3.0 m (10.5 ft)	Part No. 410300V4003
5.0 m (17.5 ft)	Part No. 410300V4005
10.0 m (35.0 ft)	Part No. 410300V4010
20.0 m (70.0 ft)	Part No. 410300V4020
Mains cable	
3.0 m (10.5 ft) (EU)	Part No. 800102V0002
3.0 m (10.5 ft) (US)	Part No. 800102V1002

MAG.DRIVE digital



MAG.DRIVE digital without plug-in control



MAG.DRIVE digital with plug-in control

Advantages to the User

- Operation of turbomolecular pumps with magnetically levitated rotors:
 - MAG (W) 830/1300 C,
 - MAG (W) 1500 C/CT,
 - MAG (W) 2000 C/CT,
 - MAG (W) 2200 C und
 - MAG (W) 2800/3200 C/CT
- Easy operation through the controls or the use of plug-in control unit
- Storing of all parameters in the pump's memory
- Communication to host computer of the customer via serial interface and conventional interface possible
- Plug-in control
- Setting of speed, temperature of the basic flange and other functions
- Small size and low weight
- Integrated fan
- Integrated temperature management system magnetic bearing control system
- Warning in case the pump is running out of specification

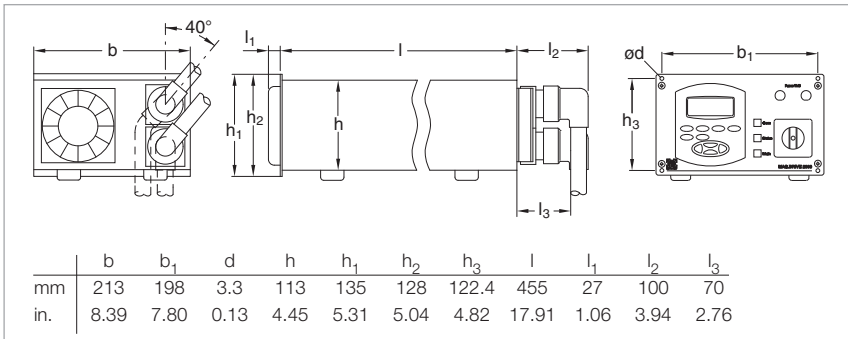

Dimensional drawing for the MAG.DRIVE digital

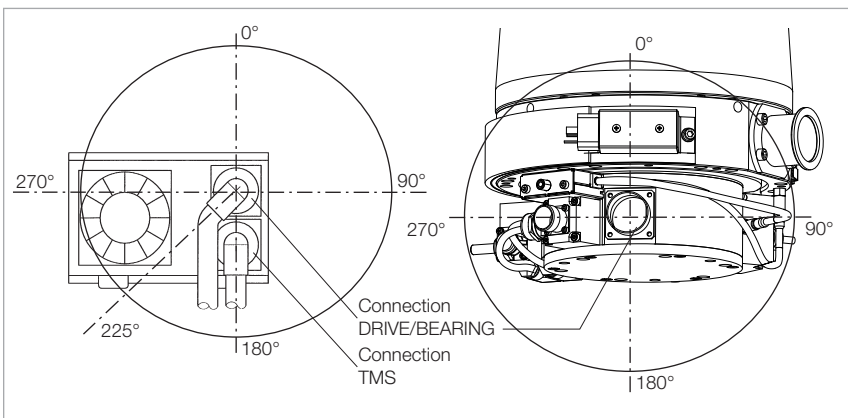

Overview connection lines

Technical Data

MAG.DRIVE digital

Mains connection, 50/60 Hz	V	200 - 240, +10%/-15%
Current for connected consumers, max.	A	20
Max. motor voltage	V	60
Nominal frequency	Hz	50/60
Permissible ambient temperature	°C (°F)	0 to +45 (+32 to +113)
Dimensions (W x H x D)	mm (in.)	483 x 213 x 1/2 19" (19.02 x 8.39 x 1/2 19")
Weight, approx.	kg (lbs)	10 (22)

Ordering Information

MAG.DRIVE digital

Electronic Frequency Converter MAG.DRIVE digital with Profibus interface with RS 232 C interface with Ethernet interface				Part No. 400035V0011 Part No. 400035V0013 Part No. 400035V0014 Part No. 400035V0015
Plug-in control				Part No. 121 36
Connection line leading to the DRIVE/BEARING of the TURBOVAC MAG ... C/CT				
	Cable outlet frequency converter	Cable outlet pump		
	DRIVE/BEARING	DRIVE/BEARING	PK	
1.5 m (5.25 ft)	bended 225°	straight	straight	Part No. 400036V0001
1.5 m (5.25 ft)	bended 40°	bended 180°	straight	Part No. 400036V0025
3.0 m (10.5 ft)	straight	bended 180°	straight	Part No. 400036V0006
3.0 m (10.5 ft)	bended 225°	straight	straight	Part No. 400036V0008
3.0 m (10.5 ft)	straight	bended 270°	straight	Part No. 400036V0009
5.0 m (17.5 ft)	bended 225°	straight	straight	Part No. 400036V0004
5.0 m (17.5 ft)	straight	straight	straight	Part No. 400036V0010
8.0 m (28.0 ft)	bended 225°	straight	straight	Part No. 400036V0005
10.0 m (35.0 ft)	bended 225°	straight	straight	Part No. 400036V0002
20.0 m (70.0 ft)	bended 225°	straight	straight	Part No. 400036V0003
23.0 m (80.5 ft)	bended 225°	straight	straight	Part No. 400036V0012
30.0 m (105 ft)	bended 225°	straight	straight	Part No. 400036V0011
TMS (only for CT versions)				
	Cable outlet frequency converter	Cable outlet pump		
	TMS	TMS	Heater	
1.5 m (5.25 ft)	bended 225°	straight	bended 180°	Part No. 400037V0001
1.5 m (5.25 ft)	bended 40°	straight	bended 180°	Part No. 400037V0025
3.0 m (10.5 ft)	bended 225°	straight	bended 180°	Part No. 400037V0008
5.0 m (17.5 ft)	bended 225°	straight	bended 180°	Part No. 400037V0004
8.0 m (28.0 ft)	bended 225°	straight	bended 180°	Part No. 400037V0005
10.0 m (35.0 ft)	bended 225°	straight	bended 180°	Part No. 400037V0002
20.0 m (70.0 ft)	bended 225°	straight	bended 180°	Part No. 400037V0003
Purge / Vent (only for optional purge vent valve Part No. 121 33)				
	Cable outlet frequency converter	Cable outlet pump		
	TMS	Purge	Vent	
1.5 m (5.25 ft)	straight	bended	bended	Part No. 400038V0007
3.0 m (10.5 ft)	bended 225°	bended	bended	Part No. 400038V0006
10.0 m (35.0 ft)	bended 225°	bended	bended	Part No. 400038V0002
20.0 m (70.0 ft)	straight	bended	bended	Part No. 400038V0009
Connector for hardware interface				upon request
19" installation frame				Part No. 161 00

Power Supply Unit TURBO.POWER 500 for MAG W 300/400/600/700 iP

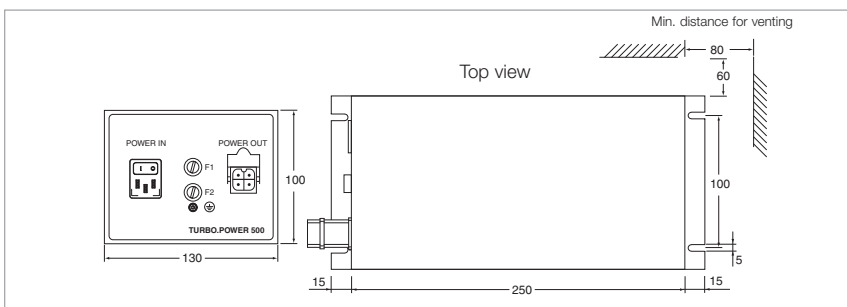

Dimensional drawing for the power supply TURBO.POWER 500

Technical Features

- For supplying 48 V DC power to the MAG W 300/400/600/700 iP
- Bench top unit or for cabinet mounting

Technical Data

Power Supply

TURBO.POWER 500

Voltage range (POWER IN)	V	100 - 240, +/-10%
Line supply frequency	Hz	50 / 60
Load		
Maximum	VA	650
at ultimate pressure operation of the pump	VA	450
DC voltage range		
POWER OUT	V DC	48
max.	A	10
Maximum length of the DC power line		
at 3 x 1,5 mm ²	m (ft)	5 (17.5)
at 3 x 2,5 mm ²	m (ft)	20 (70.0)
Temperature		
during operation	°C (°F)	+10 to +40 (+50 to +104)
during storage	°C (°F)	-10 to -70 (+14 to -94)
Relative air humidity	%	5 bis 85 (non condensing)
Protection	IP	30
Overvoltage category		II
Contamination level in accordance with EN 61010		2
Weight, approx.	kg (lbs)	4.0 (8.8)

Ordering Information

Power Supply

TURBO.POWER 500

Power supply TURBO.POWER 500	Part No. 410300V0221
DC cable (Connection between TURBO.POWER 500 and MAG.DRIVE iS)	
1.0 m (3.5 ft)	Part No. 410300V2001
3.0 m (10.5 ft)	Part No. 410300V2003
5.0 m (17.5 ft)	Part No. 410300V2005
10.0 m (35.0 ft)	Part No. 410300V2010
20.0 m (70.0 ft)	Part No. 410300V2020
Mains cable	
3.0 m (10.5 ft) (EU)	Part No. 800102V0002
3.0 m (10.5 ft) (US)	Part No. 800102V1002

(Miscellaneous) Accessories

Vibration Absorber

Vibration absorbers are used to inhibit the propagation of vibrations from the turbomolecular pump to highly sensitive instruments like electron beam microscopes, micro-balances or analytical instruments.



Ordering Information

Vibration Absorber

Vibration absorber	Part No.
DN 63 ISO-K 66 mm (2.60 in.) long	800131V0063
DN 63 CF 81 mm (3.19 in.) long	500 070
DN 100 ISO-K 84 mm (3.31 in.) long	800131V0100
DN 100 CF 100 mm (4.09 in.) long	500 071
DN 160 ISO-K 84 mm (3.31 in.) long	500 073
DN 160 CF 104 mm (4.09 in.) long	500 072

Air Cooling Unit

Also an air cooling unit is available as a retrofit kit for convection cooling of the TURBOVAC 50 pump with air. This kit can be easily fitted to the pump in each case using the mounting components contained in the kit.



Technical Data

Air Cooling Unit

Rated power consumption of the air cooling unit when connected to	W
TURBOVAC 50, 151 (C)/361 (C)	10.5
TURBOVAC 600 C, 1000 C	21.0

Ordering Information

Air Cooling Unit

Air cooling unit for	230 V	110 V	100 V
TURBOVAC 50	Part No. 854 05	Part No. 854 06	Part No. 800152V0015
TURBOVAC 151 (C)/361 (C)	Part No. 855 31	Part No. 894 08	Part No. 800152V0016
TURBOVAC 600 C, 1000 C	Part No. 855 41	Part No. 170 016	Part No. 800152V0017

Flange Heaters for CF Highvacuum Flanges

Most TURBOVAC pumps can be baked out in order to improve the ultimate pressure attained in the UHV range. Degassing of the turbo-molecular pump will only be useful when simultaneously baking out the vacuum chamber.



Technical Data

Flange Heater

Rated power consumption of the flange heater		
DN 63 CF, DN 100 CF	W	100
DN 160 CF	W	150

Ordering Information

Flange Heater

Flange heater	230 V	110 V
DN 63 CF	Part No. 854 04	Part No. 854 07
DN 100 CF	Part No. 854 27	Part No. 854 28
DN 160 CF	Part No. 854 37	Part No. 854 38

Fine Filter

A fine filter integrated in the centering ring protects the pump against particles and dust on the highvacuum side.

Ordering Information

Fine Filter

Connection flange of the fine filter	
DN 40 KF	Part No. 883 98
DN 63 ISO-K	Part No. 887 20
DN 100 ISO-K	Part No. 887 21

The following accessories are also available:

Vacuum gauge COMBIVAC 2T
Part No. 230 000
(see Product Section C16)

Delayed venting unit
Part No. 500 441
(see Product Section C10)

Solenoid Venting Valve

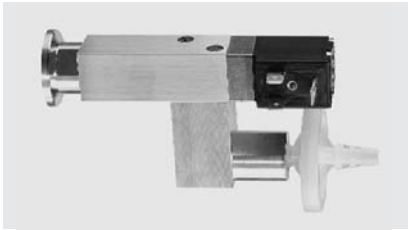

Technical Data

Drive voltage	V DC	24
Power consumption	W	4
Connecting flange	DN	16 ISO-KF
Weight, approx.	kg (lbs)	0.3 (0.66)

Venting Valve

Ordering Information

Solenoid venting valve,
normally closed

Venting Valve

Part No. 800120V0011

Further vent valves available in US. Please contact your US sales office

Power Failure Venting Valve

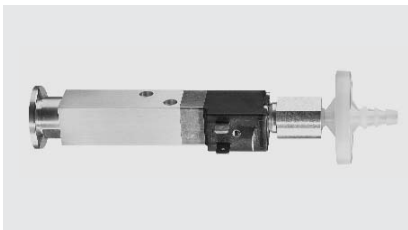

Technical Data

Drive voltage	V DC	24
Power consumption	W	4
Connecting flange	DN	16 ISO-KF
Weight, approx.	kg (lbs)	0.3 (0.66)

Power Failure Venting Valve

Ordering Information

Power failure venting valve,
normally open

Power Failure Venting Valve

Part No. 800120V0021

Further vent valves available in US. Please contact your US sales office

Purge Gas and Venting Valve



Technical Data

Connecting flange	DN	10 ISO-KF
Weight, approx.	kg (lbs)	0.7 (1.55)

Purge Gas and Venting Valve

Ordering Information

Purge gas and venting valve, 230 V
0.2 mbar x l x s⁻¹ (12 sccm)
0.4 mbar x l x s⁻¹ (24 sccm)

Purge Gas and Venting Valve

Part No. 855 19
Part No. 855 29

Purge gas and venting valve, 110 V
0.2 mbar x l x s⁻¹ (12 sccm)

Part No. 190 351 069

Purge Gas and Venting Valve

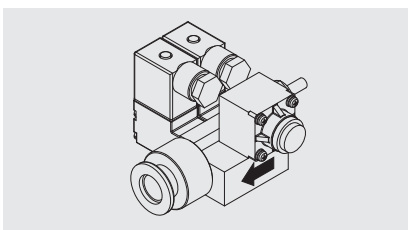

Technical Data

Connecting flange		
Inlet		1/4" pipe
Outlet		pump specific or DN 16 ISO-KF
Purge gas pressure, abs.	bar	1.5 to 6.0
Weight, approx.	kg (lbs)	0.5 (1.1)

Purge Gas and Venting Valve

Ordering Information

Purge gas and venting valve, 24 V DC
0.6 mbar x l x s⁻¹ (36 sccm)

Purge Gas and Venting Valve

Part No. 121 33

Further 0.6 mbar x l x s⁻¹ valves upon request

Accessories for Serial Interfaces RS 232 C and RS 485 C

Through these accessories many control, monitoring and information capabilities can be implemented in connection with the electronic frequency converters and turbomolecular pumps.

The following turbomolecular pumps or electronic frequency converters are supported:
TW 70 H / TURBO.DRIVE S
TW 250 S / TURBO.DRIVE S / TURBO.DRIVE 300

TW 300, TW 300 H /
TURBO.DRIVE S / TURBO.DRIVE 300
TW 701
T 1600, TW 1600

Software

Ordering Information

Software
"Turbo.Drive Panel", 3.5 in. floppy ¹⁾

Display Unit

Part No. 800110V0104 ¹⁾

¹⁾ The panel software can be downloaded from "www.oerlikon.com"

PC Software

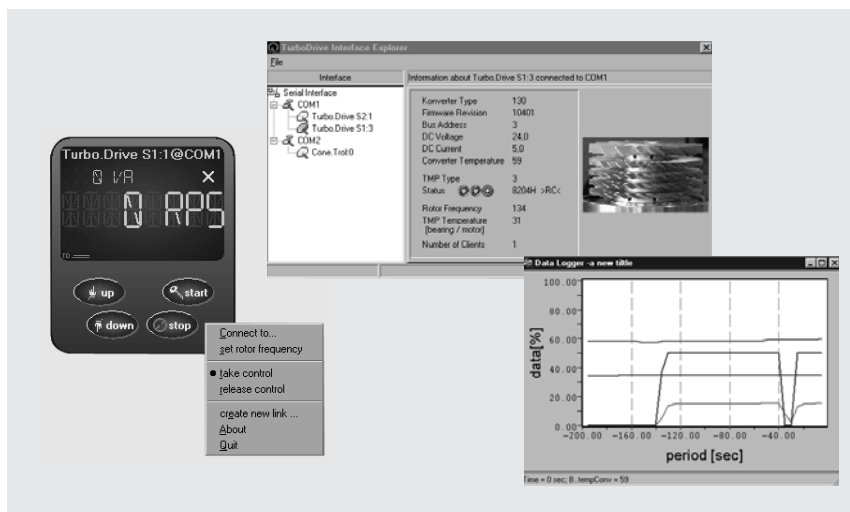

PC software for Windows 95 or higher

Technical Features

- Convenient graphical user interface
- Several turbomolecular pumps can be operated in parallel
- Display, modify, save and compare the parameter lists of the turbomolecular pumps
- Integration of customer's software
- Recording parameter data over time (for example, temperatures, rotor frequency)

Ordering Information

PC software
"Turbo.Drive Server", CD ROM ¹⁾

PC Software

Part No. 800110V0102 ¹⁾

¹⁾ The PC software can be downloaded from "www.oerlikon.com"
Software supports only RS 232 C, RS 485 C and Profibus

Adaptor RS 232 C/RS 485 C for Frequency Converter with RS 485 C Interface

Ordering Information

Adaptor RS 232 C/RS 485 C

Adaptor RS 232 C/RS 485 C,
mains connection 220 V, 50 Hz, EURO plug

Part No. 800110V0101

