



## Agilent VS Series Leak Detectors

Wide range, high performance systems.



# The Agilent Advantage

## Global Applications Support

### Expertise When and Where You Need It

- Native language specialists available locally worldwide
- Application specific consulting
- More than ten thousand installed systems delivering application solutions to customers in a broad range of industries



*Maximizing  
Productivity  
and Uptime*

## High Performance Instruments

### VS Series Leak Detectors

- Easy to Use
- Powerful
- Versatile
- Dependable
- Truly Portable



## Industry Leading Service & Support

### Get The Most From Your Investment

- Most extensive network of service engineers available locally to meet your needs
- Exchange inventory for replacement components
- On-site or factory repair
- Full range of standard and customized support plans



# Features and Benefits



## Easy-to-Use – Two Button Operation

VS Series Leak Detectors combine the simplicity of two-button operation with advanced system intelligence.

- Fully automated start-up and calibration maximizes productivity
- Intuitive menu structure is easy to navigate
- Programmable test sequences improves testing efficiency
- Color touch screen provides excellent clarity, even at wide angles



## Powerful – Broad Range of Test Methods

The state-of-the-art spectrometer and vacuum system design provides powerful capability, enabling a broad range of test methods for specific applications.

- High test port pressure allows detection of large leaks
- 12-range MDL (minimum detectable leak) meets the most stringent leak test requirements
- High helium pumping speed ensures fast system response and clean-up times
- New high efficiency ion source and beam optics optimize sensitivity and mass separation



## Versatile – Multiple System Configurations

A wide range of options allows for broad configuration flexibility, meeting all application requirements and test environments.

- Primary pump and system mounting options may be selected to best suit your needs
- Multiple language and units capability permits easy implementation worldwide
- Compact lightweight design enables easy transport from one test location to another



## Dependable – Robust Design

Robust design innovations allow the VS series to conform to the most rigorous industrial standards and operate dependably in the most challenging environments.

- Fast clean-up time enhances system up-time
- Robust Faraday cup technology delivers proven reliability with low cost of ownership
- Conforms to CE, UL and CSA standards, assuring global acceptance



## Truly Portable – Wireless Remote Control/Display

Hand-held remote performs essential functions up to 100 meters (328 feet) indoors, facilitating access to all leak sites.

- Eliminates cumbersome cables while extending range
- Allows testing of large systems by a single operator
- Leak detector can be located outside cleanroom to prevent contamination
- Multiple channels for use of one remote with up to twenty leak detectors

# Technical Specifications

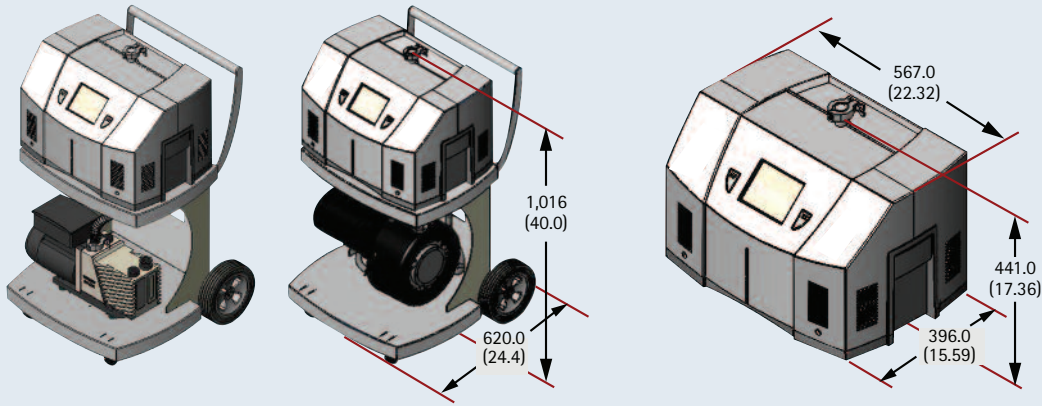

UL/CSA, CE Approved

Dimensions: millimeters (inches)

Technical Specifications		
Model Number	PR02/PD03	MR15 & MD30
Configuration Options	Bench Top	Bench Mount or Mobile
Primary Pump Type	Rotary vane pump Dry scroll pump	DS-302 14 m <sup>3</sup> /hr (232 l/m) TS-620 30 m <sup>3</sup> /hr (500 l/m)
Minimum Detectable Leak at 1000 ppm ambient He	5 x 10 <sup>-12</sup> atm cc/sec : 5 x 10 <sup>-12</sup> mbar l/s : 5 x 10 <sup>-13</sup> Pa m <sup>3</sup> /sec helium	
Maximum Test Port Pressure	13 mbar, 10 Torr, 1330 Pa	
Helium Pumping Speed @ Test Port (Fine Test)	1.8 l/s	
Calibration Routine	Automated or manual (internal or external)	
Background Suppression	Push button initiated auto zero, and auto zero < zero function	
User Interface	High clarity, color display, TFT touch screen	
Selectable Languages	English, French, German, Japanese, Korean, Mandarin, Spanish	
Automated Cycling	Programmable rough time, test time, reject set points	
Response Time	< 0.5 seconds	
Set Points	Standard, 5 set points, N/O or N/C; 3 leak rate, 1 pressure, 1 audio	
Communications Interface	RS-232 isolated interface @ 9600 baud (DB-9S)	
Discrete I/O	Optically isolated, 5-24 VDC outputs and inputs (DB-25S)	
Wireless Remote Control (optional)	2.4 GHz ISM band, 100m (328 ft) range, 4 AA batteries or 5 VDC supply	

Ordering Information				
Model Number	Description	120 Volt	220 Volt	Weight
VS PR02	Portable Leak Detector, DS42 Rotary Vane Pump	VSPR021	VSPR022	63 kg (140 lbs)
VS PD03	Portable Leak Detector, Dry Pump Combo	VSPD031	VSPD032	57 kg (125 lbs)
VS MR15	Mobile Leak Detector, DS302 Rotary Vane Pump	VSMR151	VSMR152	105 kg (230 lbs)
VS MD30	Mobile Leak Detector, TS620 Dry Scroll Pump	VSMD301	VSMD302	114 kg (250 lbs)
VS BR15	Bench Mount Leak Detector, DS302 Rotary Vane Pump	VSBR151	VSBR152	75 kg (165 lbs)
VS BD30	Bench Mount Leak Detector, TS620 Dry Scroll Pump	VSBD301	VSBD302	83 kg (183 lbs)
Options/Accessories		Factory Installed	Field Installed	
Oil Mist Eliminator, PR02		VSFACME	VSFLDME	
Wireless Remote, Base Unit		VSFACWB	VSFLDWB	
Hand-held Remote Control			VSLDWRC	
Discrete I/O		VSFACIO	VSFLDIO	
Leak Test Data Wizard Software			VSLTDW	
1 1/8 in. Compression Test Port			VSFLDCP	
Power Probe Sniffer, NW25			K9565306	

# Applications



## Industrial Process Tools

VS Series Leak Detectors rid process tools of costly, inefficient leaks. Robust system features assure reliable operation in the most challenging industrial environments. Pumping characteristics such as high inlet pressure tolerance and split flow capability deliver fast response and clean-up times. Wireless remote enables single-person leak testing of even the largest systems.

- Vacuum furnaces
- Coating systems
- Electronic beam welders



## Power Generation

Leaks in power plant condensers can cause significant efficiency loss. High inlet pressure tolerance, auto-zero function, and cart-mounted mobility simplify the leak detection process. Simple, intuitive operation allows intermittent use without excessive training. Wireless remote – range 100 meters (328 feet) – provides true hand-held portability enabling leak testing by one person.

- Condensers
- Heat exchangers
- Steam circuits
- Underground pressured power cables

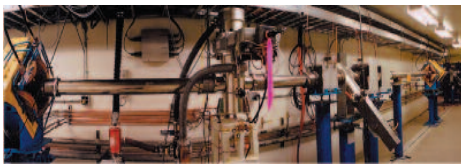

## High Energy Physics

Leak testing accelerators and beam lines requires high sensitivity, large roughing capacity and portability. The VS Series provides excellent mass separation that differentiates the smallest helium leaks from residual water vapor and hydrogen. They are available with large, dry roughing pumps to evacuate large volumes, or smaller internal pumps used with turbo pumping systems. Wireless remote – range 100 meters (328 feet) – enables a single operator to check potential leak sites without a cord or any kind.

- Accelerators
- Beam lines
- Synchrotrons

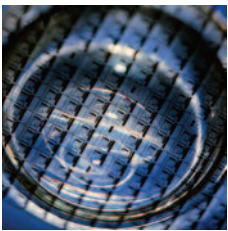

## Semiconductor Production

The VS Series combine high sensitivity and large, dry rough pumping capacity to meet the testing needs of semiconductor processing equipment and gas handling systems. With the high inlet pressure tolerance and fast clean up and response times, these units locate leaks in both evacuated and pressurized systems. A clean room technician can use the hand-held wireless remote control while the leak detector remains installed in a less critical area.

- Process tools
- Gas panels
- Gas transfer lines



## Small Parts Manufacturing

VS Series Leak Detectors employ high inlet pumping speed and high inlet pressure tolerance to minimize test cycle time, thereby maximizing production throughput. Programmable test sequences simplify daily operation, minimize operator error, and maximize your production efficiency. Optional *Leak Test Data Wizard* software can be used to collect data for quality control purposes and even automate test cycles.

- Automotive
- Electrical
- Refrigeration
- Hermetic packaging
- Medical and Implantable devices

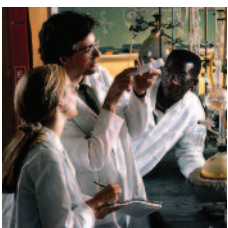

## General R&D

Research and university labs often require a portable leak detector with the versatility to cover a wide range of applications. Easy transportability from lab to lab, in conjunction with high performance specifications in both the evacuation and pressurized mode, make the VS Series an essential tool for this environment.

- Electron microscopes
- Experimental chambers
- Surface analytical systems
- Space chambers



# Service & Support

## United States and Canada

Agilent Technologies  
121 Hartwell Avenue  
Lexington, MA 02421 USA  
Tel.: +1 781 861 7200  
Toll-Free: +1 800 882 7426  
Fax: +1 781 860 5437  
vpl-customerservice@agilent.com

## Benelux

Agilent Technologies Netherlands B.V.  
Herculesweg 8  
4338 PL Middelburg The Netherlands  
Tel: +31 118 671570  
Fax: +31 118 671569  
Toll free: 00 800 234 234 00

## China

Agilent Technologies (China) Co. Ltd  
No.3, Wang Jing Bei Lu,  
Chao Yang District,  
Beijing, 100102 China  
Tel.: +86 (10) 6439 7888  
Fax: +86 (10) 6439 1318  
Toll-Free: 800 820 8266  
vpc-customerservice@agilent.com

## France

Agilent Technologies France  
7 avenue des Tropiques  
Z.A. de Courtaboeuf – B.P. 12  
91941 Les Ulis cedex France  
Tel.: +33 (0) 1 69 86 38 84  
Fax: +33 (0) 1 69 86 29 88  
Toll free: 00 800 234 234 00  
vpf.sales@agilent.com

## Germany & Austria

Agilent Technologies  
Alsfelder Strasse 6  
Postfach 11 14 35  
64289 Darmstadt Germany  
Tel.: +49 (0) 6151 703 353  
Fax: +49 (0) 6151 703 302  
Toll free: 00 800 234 234 00

## India

Agilent Technologies India Pvt. Ltd.  
G01, Prime corporate Park,  
230/231, Sahar Road,  
Opp. Blue Dart Centre,  
Andheri (East), Mumbai – 400 099 India  
Tel: +91 22 30648287/8200  
Fax: +91 22 30648250  
Toll Free: 1800 113037  
cag\_india@agilent.com

## Italy

Agilent Technologies Italia S.p.A.  
via F.lli Varian 54  
10040 Leini, (Torino) Italy  
Tel.: +39 011 997 9111  
Fax: +39 011 997 9350  
Toll-Free: 00 800 234 234 00  
vpt.sales@agilent.com  
vpt-customerservice@agilent.com

## Japan

Agilent Technologies Japan, Ltd.  
8th Floor  
Sumitomo Shibaura Building  
4-16-36 Shibaura Minato-ku  
Tokyo 108-0023 Japan  
Tel.: +81 3 5232 1253  
Toll-Free: 0120 655 040  
Fax: +81 3 5232 1710  
vpj-customerservice@agilent.com

## Korea

Agilent Technologies Korea Ltd.  
Shinsa 2nd Bldg. 2F  
966-5 Daechi-dong  
Kangnam-gu, Seoul Korea 135-280  
Tel.: +82 2 3452 2455  
Toll-Free: 080 222 2452  
Fax: +82 2 3452 2451  
vpk-customerservice@agilent.com

## Mexico

Agilent Technologies  
Concepcion Beistegui No 109  
Col Del Valle  
C.P. 03100 Mexico, D.F.  
Tel.: +52 5 523 9465  
Fax: +52 5 523 9472

## Singapore

Agilent Technologies Singapore Pte Ltd  
No.1 Yishun Avenue 7 Singapore 768923  
Tel: +65 6215 8045  
Fax: +65 6754 0574  
Toll-Free: 1 800 2762622  
vps-customerservice@agilent.com

## South East Asia

Agilent Technologies Sales Sdn Bhd  
Unit 201, Level 2 uptown 2,  
2 Jalan SS21/37, Damansara Uptown  
47400 Petaling Jaya, Selangor, Malaysia  
Tel: +603 7712 6106  
Fax: +603 6733 8121  
Toll-Free: 1 800 880 805  
vps-customerservice@agilent.com

## Taiwan

Agilent Technologies Taiwan Limited  
20 Kao-Shuang Rd.,  
Pin-Chen City, 324  
Taoyuan Hsien, Taiwan, R.O.C.  
Tel. +886 34959281  
Toll Free: 0800 051 342  
vpw-customerservice@agilent.com

## UK & Ireland

Agilent Technologies UK Ltd  
6 Mead Road  
Oxford Industrial Park  
Yarnton, Oxford OX5 1QU UK  
Tel.: +44 (0) 1865 291570  
Fax: +44 (0) 1865 291571  
Toll free: 00 800 234 234 00  
vpt-customerservice@agilent.com

## Learn more:

[www.agilent.com/chem/leakdetection](http://www.agilent.com/chem/leakdetection)

This information is subject to change  
without notice.

© Agilent Technologies, Inc., 2011  
Published in USA, August, 2011



**Agilent Technologies**